



Beta

2021

78

LISTINO PREZZI

Prezzi I.V.A. esclusa



LA STORIA DELL' UTENSILERIA ITALIANA

1923 ● Alessandro Ciceri fonda la stamperia "Alessandro Ciceri & Figli", specializzata in stampei di ferro e acciaio.

1939 ● Viene depositato il marchio Beta e l'Azienda si specializza nella produzione di utensili per uso professionale.

1960 ● Beta Utensili conta duecento dipendenti, esporta i propri prodotti all'estero e si afferma quale realtà emergente nel settore dell'utensileria professionale.

1969 ● Nasce il rivoluzionario carrello "Tank" in lamiera arancione, il colore che, da quel momento in poi, renderà inconfondibile lo stile del marchio Beta.

1971 ● Beta Utensili entra nel mondo delle competizioni motoristiche intese come momento di verifica e sviluppo dei propri prodotti.

1975 ● Arriva il primo grande successo in Formula 1 con la **March-Beta Utensili** di colore arancione di Vittorio Brambilla che vince il Gran Premio d'Austria nel diluvio di Zeltweg.

1980 ● Aumenta la penetrazione nei più importanti mercati Europei con la costituzione progressiva di filiali Beta Utensili in Francia, Gran Bretagna, Olanda, Spagna, Polonia e Ungheria.

1995 ● In soli 8 mesi l'Azienda ottiene la certificazione **Sistema di Qualità ISO 9001**.

2000 ● La presentazione del nuovo catalogo Beta Utensili conferma il continuo processo di crescita. Raddoppia la gamma dei prodotti in offerta e le oltre 10000 referenze vengono suddivise in 22 famiglie di prodotto.

2002 ● L'offerta Beta Utensili viene ulteriormente ampliata con l'introduzione della gamma di calzature antinfortunistiche e la linea di abbigliamento da lavoro e tempo libero "Beta Work".

2009 ● Beta espande ulteriormente i propri mercati aprendo la nuova filiale Beta Cina.

2012 ● Apre Beta Brasile

2016 ● Beta introduce il nuovo sistema modulare per l'arredo officina RSC55.

2018 ● **BM** Entra a far parte del gruppo Beta l'azienda BM S.p.A. leader nella produzione e commercializzazione di capicorda e sistemi di connessione elettrica.

2019 ● Beta Utensili acquisisce il controllo di **Abra Beta S.p.A.**, leader nella produzione di abrasivi rinforzati ad impasto resinoidi per la sbavatura e il taglio di tutti i materiali e di mole a gambo.

2020 ● Con l'acquisizione di **Elpa Abrasivi S.r.l.**, punto di riferimento nel mercato degli abrasivi flessibili, Beta crea un polo nazionale di competenze che le permettono di entrare con autorevolezza nel settore degli abrasivi, fornendo al mercato una nuova e completa offerta di articoli professionali. Nasce **Beta Tools USA**, un passo importante nella strategia di espansione sul mercato nordamericano.

2021 ● Un percorso di crescita senza interruzioni conduce alla realtà odierna: una gamma prodotto distribuita in tutto il mondo, che supera le **15.000 referenze** e comprende articoli adatti a soddisfare le esigenze dei professionisti più esigenti.

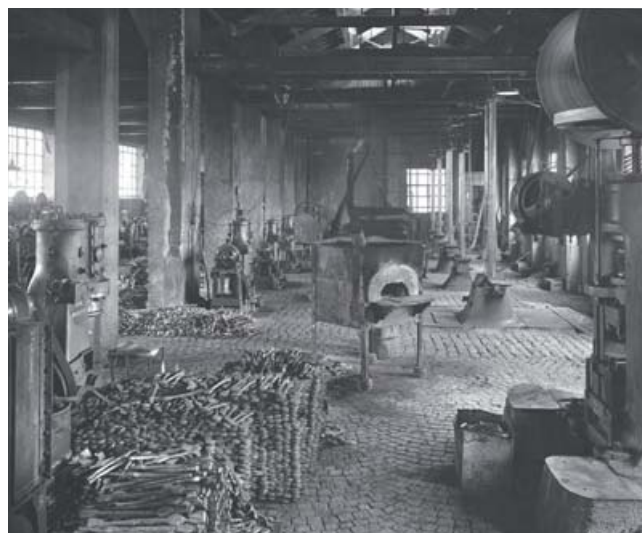

1939 Reparto forgia



1950 Reparto galvanica



1955 Reparto tranciatura



1960 Magazzino spedizioni



1969 Carrello Tank

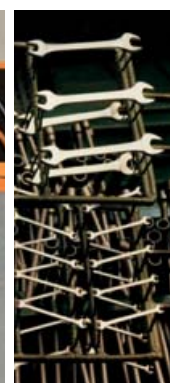

1975 Cromatura



1974 Vittorio Brambilla



1980 Reparto meccanica



2002 "BetaWork"



2016 Arredo Officina RSC55



2020 Jorge Navarro



1939



1950



1960



1970



1980



Beta

— GROUP —



8 Unità
produttive
IN ITALIA



Oltre
800 addetti

11 Filiali
nel mondo
9 Beta - 2 BM

Presenti in più
di **100 Paesi**
nel mondo
con oltre **250**
importatori



BETA UTENSILI S.p.A. - 20845 Sovico (MB)
Via A. Volta, 18 - Tel. 039.2077.1 - Fax 039.2010742
www.beta-tools.com

Sede produttiva Accessori per funi Robur:
67039 Sulmona (AQ) Zona industriale - C.da S. Nicola
Tel. 0864.2504.1 - Fax 0864.253132
www.roburitaly.com - info@roburitaly.com

RICERCA E SVILUPPO



42

La nostra storica chiave 42 ha una nuova forma. Una forma **elegante e snella**, alleggerita nelle linee e più leggera al tatto. La **forza**, la **resistenza** e l'**ergonomia** della chiave Beta raggiungono valori ancora superiori per offrire la miglior chiave possibile alle mani degli utilizzatori. Il processo produttivo si svolge nei nostri **stabilimenti di Sovico e Sulmona**, avvalendosi delle tecnologie più avanzate in termini di automazione e degli operatori più preparati in termini di esperienza.

FORZA

Valori di coppia più che doppi rispetto ai requisiti della norma ISO 1711.

RESISTENZA

Grande resistenza: nel caso di uso improprio la chiave inizia a deformarsi, non si spezza in modo improvviso e pericoloso.

ERGONOMIA

L'occhio poligonale è inclinato di 15° per proteggere la mano. La forma è ottenuta da stampo, non piegata successivamente.



ATTENZIONE! La nuova forma della chiave 42 è **perfettamente compatibile** con tutti i contenitori e i moduli della chiave 42 storica

Beta **EVOR**

l'evoluzione del giravite!

Il **design ergonomico** si adatta perfettamente al palmo della mano.

L'ampia superficie di contatto permette di trasmettere il **massimo della forza** con il minore sforzo.

La nuova gomma termoplastica rende ancora più **confortevole** ogni utilizzo, anche il più gravoso.

L'**area di precisione** permette al giravite di girare rapidamente tra le dita.

Le collaudate lame Beta offrono **elasticità, durezza e resistenza all'usura** ai vertici della categoria dei giravite professionali.



Novità assoluta è la sua **appendibilità**, grazie al foro sull'impugnatura.

Impronta e misura sono riportate sulla **calotta sferica** per una rapida individuazione.

La **sezione ottagonale** evita il fastidioso rotolamento sul piano di lavoro.



RICERCA E SVILUPPO



1150 GRANDE POTENZA DI TAGLIO

Il perno decentrato aumenta l'effetto leva, riducendo lo sforzo, per un **taglio di grande potenza**. Il profilo assottigliato garantisce una presa sicura anche in spazi molto ristretti.

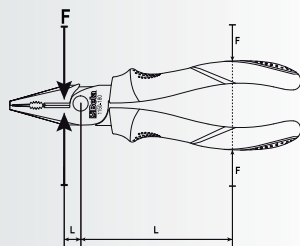

INDUSTRIAL
FINISHING



La gamma di pinze si completa con **una nuova finitura** dedicata ai professionisti della manutenzione industriale. Oltre a garantire elevate prestazioni, permette una valida alternativa alla finitura cromata grazie al suo ottimo **rapporto qualità/prezzo**.



COLOR CODE

Una nuova gamma di utensili per identificare rapidamente quello che ti serve!

Un colore, una misura

Un colore, un'impronta



Beta CHEMICALS

MADE IN ITALY

Stringere un bullone non è sempre sufficiente per ottenere un serraggio sicuro. Occorre pulirlo, lubrificarlo, sigillarlo!

La produzione interamente italiana, la scelta delle materie prime e la continua innovazione dei cicli produttivi ci ha permesso di sviluppare prodotti di elevato rendimento e con prestazioni al vertice della categoria.

Scopri la nuova gamma **Beta Chemicals** nella sezione dedicata.



Beta ABRASIVES

MADE IN ITALY

La nuova famiglia **Beta Abrasives** offre una gamma completa di abrasivi rigidi e flessibili e un servizio tecnico assoluto ai professionisti del mercato, garantito dalle competenze produttive apportate da **AbraBeta** ed **Elpa**, due aziende leader nel settore.

QUALITÀ CERTIFICATA

La maggior parte delle cassette Beta dal 2018 si fregia del prestigioso marchio TÜV, ottenuto superando gli stretti controlli del protocollo di prova EK5/TA5.

Il protocollo EK5/TA5 prevede 31 caratteristiche costruttive ben definite, stringenti test statici e test di comportamento dinamico. Altri test definiscono la resistenza alle alte e basse temperature, la durata delle marcature nel tempo e la resistenza alla corrosione.

Il raggiungimento di questo traguardo premia la progettazione esperta, la realizzazione accurata e i controlli stringenti che Beta attua nella produzione di cassette e che ne hanno garantito fino ad oggi l'apprezzamento degli utilizzatori finali.



CONTROLLO E QUALITÀ

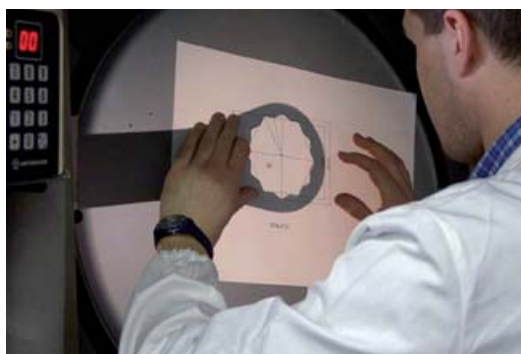
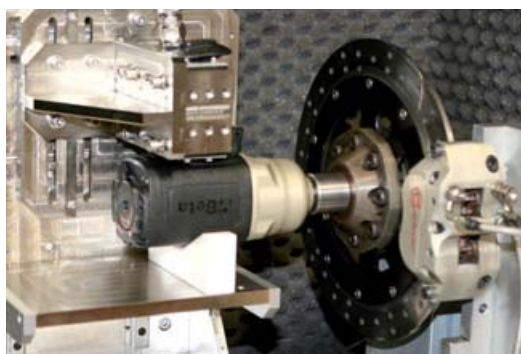
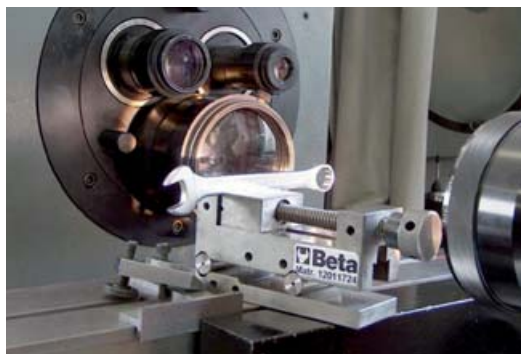

In Beta la qualità assume un significato semplice e concreto: "ciò che soddisfa in modo completo le esigenze e le aspettative di quell'utenza professionale che fa del nostro prodotto uno strumento fondamentale per il proprio lavoro". L'utensile non è solo studiato e realizzato correttamente per adempiere alla sua funzione, ma garantisce la ripetitività delle prestazioni in modo omogeneo nel tempo. La qualità in Beta non si esprime solo con un'attenta politica industriale e commerciale, ma si spinge oltre, permeando ogni divisione aziendale con il medesimo orientamento per raggiungere obiettivi sempre più ambiziosi in termini di soddisfazione della clientela. È su questo concetto che Beta ha costruito la sua storia.

**Qualità Beta,
l'aspetto più
concreto**

**La qualità degli
utensili Beta
è la sintesi
di antiche tecniche
e nuove tecnologie.**



Dal 1995 i processi produttivi sono certificati conformi agli standard del Sistema di Qualità ISO 9001



ORGANIZZARE IL LAVORO

5S è una metodologia di organizzazione dell'area di lavoro di origine giapponese. Trae il nome dalla trascrizione occidentale di 5 parole giapponesi: **seiri**, **seiton**, **seiso**, **seiketsu** e **shitsuke**.

Seguendo i 5 passaggi identificati dalle parole si ottiene un metodo sistematico e ripetibile per l'ottimizzazione degli standard di lavoro e per il miglioramento delle performance operative.



SEIRI

Selezione

Elimina il superfluo dallo spazio di lavoro e mantieni solo gli strumenti di cui hai bisogno.



SEITON

Sistematizza

Crea ordine: ogni cosa al suo posto e un posto per ogni cosa.



SEISO

Sistema

Pulisci il tuo spazio di lavoro e mantieni l'ordine nel tempo.



SEIKETSU

Standardizza

Stabilisci delle metodologie ripetitive per continuare a razionalizzare le risorse e gli spazi, definendo uno standard da seguire.



SHITSUKE

Supporta

Sostieni e diffondi questo modo di pensare e di agire in tutte le attività aziendali.



BENEFICI



Risparmio di tempo e riduzione dei costi



Miglioramento della qualità e della produttività



Riduzione degli infortuni sul lavoro



Incremento dell'efficienza



PRIMA

DOPO



PRESENZA EFFICACE

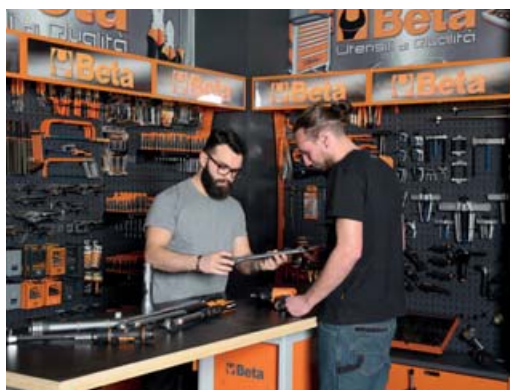

I Promotori Tecnici guidano la flotta dei Van dimostrativi Beta fino ai luoghi di lavoro per ascoltare le esigenze di chi utilizza ogni giorno gli utensili in modo professionale. È uno scambio reciproco di informazioni, indicazioni, consigli e soluzioni, che arricchiscono la conoscenza di entrambe le parti. I Van Beta sono allestiti con le ultime novità e con le attrezzature più complesse: l'utilizzatore può testare i prodotti, vedere come funzionano, e valutarne qualità e caratteristiche.



**Unità
dimostrativa
2020**

GAMMA E REFERENZE

Oltre 15.000 referenze

Grazie al proprio dinamismo, l'azienda è stata capace, nel corso degli anni, di aggiornare efficacemente la propria offerta per rispondere prontamente alle sfide del mercato mondiale.

Beta Utensili vanta oggi una gamma con più di 15.000 referenze suddivise in 30 famiglie di prodotto, posizionandosi tra le più qualificate realtà aziendali nel settore dell'utensileria.

Beta produce utensili per gli specialisti della meccanica, della manutenzione industriale, dell'autoriparazione ma anche per coloro per cui un hobby è molto di più che un semplice passatempo.

30

Famiglie

Ogni esigenza
professionale
trova una risposta
efficace

Applicazioni



Automotive



Energia



Industria



Oil & Gas



Aeronautica

SUPPORTO ALLA VENDITA

www.beta-tools.com

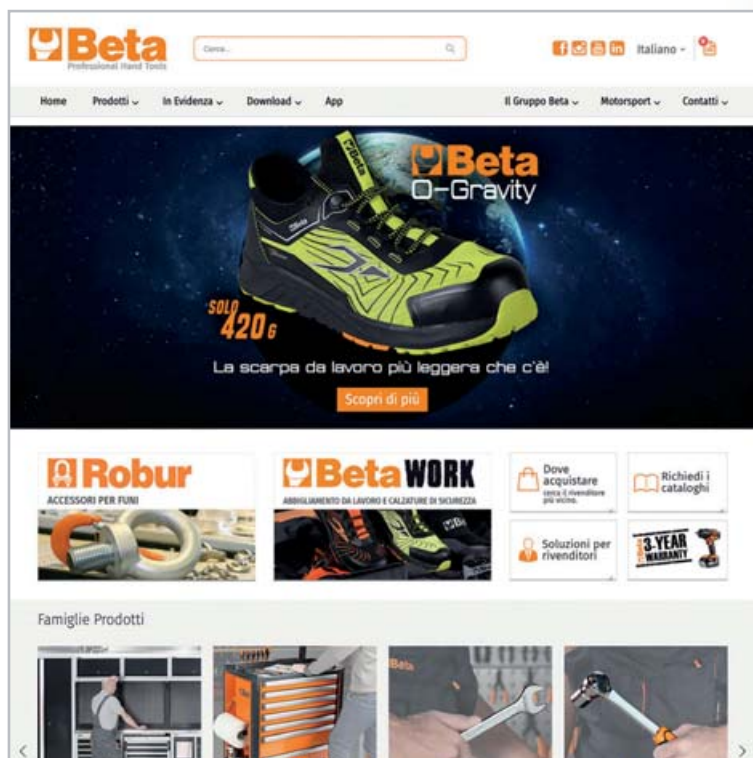

Un sito "facile" e completo dove è possibile trovare i cataloghi aggiornati, le ultime novità, le promozioni nonché tutte le informazioni tecniche relative ai prodotti (manuali, ricambistica e video dimostrativi, questi ultimi pubblicati anche su YouTube).



Beta offre numerose soluzioni espositive per il punto vendita per garantire al cliente un servizio "chiavi in mano".



App IOS e Android, l'applicazione specifica con tutti i cataloghi Beta.



Autopromotec 2019

DISTRIBUZIONE NEL MONDO



Beta è presente
in più di **100 Paesi**
nel mondo

**La capillarità
della rete
distributiva Beta**
permette di raggiungere
agevolmente gli
utilizzatori professionali
di tutto il mondo.

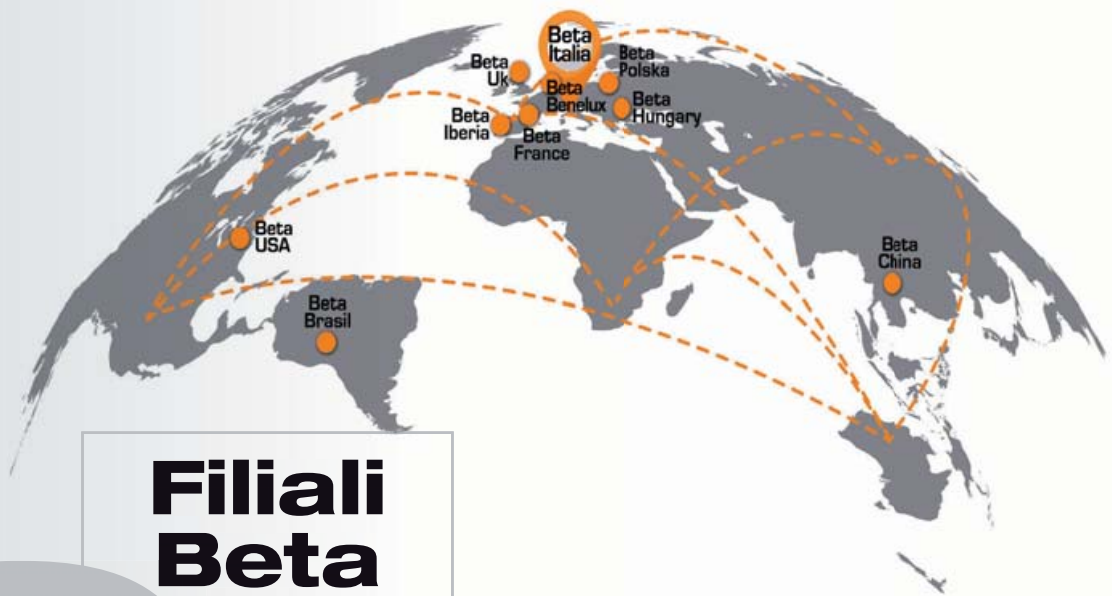

Filiali Beta

9

Beta China



Beta France



Beta Iberia



Beta Polska



Beta USA



Beta Brasil



Beta Benelux



Beta UK



Beta Hungary



LOGISTICA



**16.000 m²
di superficie**



15.000
i codici gestiti
con oltre **27.000**
unità di carico



**Consegne
veloci, accurate
e complete**



INDICE GENERALE

ARREDO OFFICINA **RSC55**



□ 374+397

RSC55

ARREDO OFFICINA **C45**



□ 398+409

CONTENITORI E ASSORTIMENTI



□ 313+371



□ 410+497

CHIAVI DI MANOVRA



□ 24+30



□ 36+39



□ 110+114

CHIAVI A BUSSOLA E ACCESSORI



□ 73+79



□ 86+110

CHIAVI DINAMOMETRICHE E MOLTIPLICATORI



□ 63-64



□ 65+72

GIRAVITE, CHIAVI MASCHIO E INSERTI



PINZE E TRONCHESI

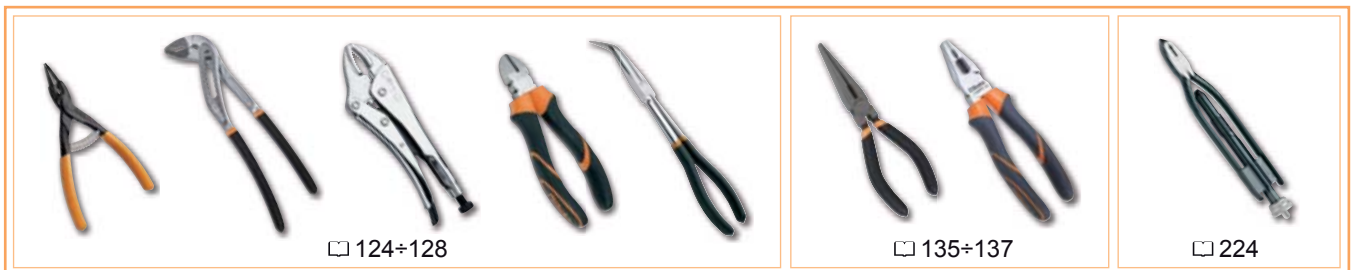

MARTELLI E SCALPELLI



UTENSILI PER FORARE E FILETTARE



ESTRATTORI

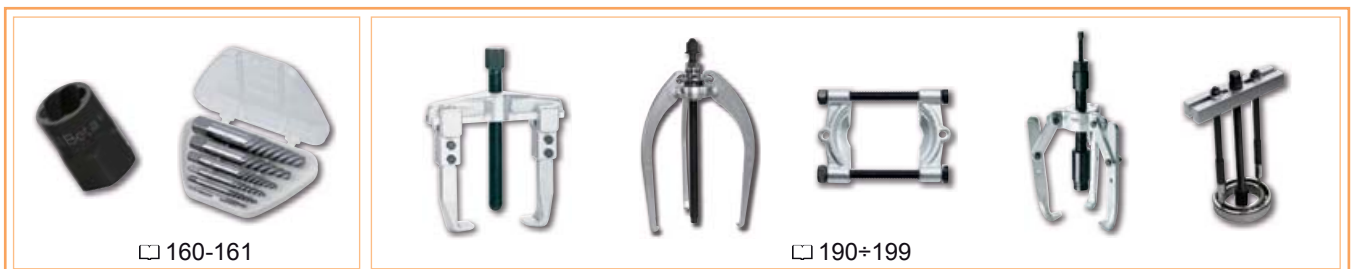

UTENSILI PER MISURARE E TRACCIARE



UTENSILI PER TAGLIARE E MANUTENZIONI VARIE



□ 120



□ 129÷133



□ 149-150



□ 175-176



□ 199



□ 209÷217



□ 225÷239

IDRAULICA



□ 39÷45



ELETTRONICA E MICROMECCANICA



□ 122-123



□ 137÷139



□ 142÷144



□ 228-229

ELETTROTECNICA



□ 132÷134



□ 143



□ 199÷202



□ 221÷225

UTENSILI ISOLATI



□ 261÷267

UTENSILI INOX



Beta
INOX
STAINLESS STEEL

□ 275+279

UTENSILI ANTISCINTILLA



□ 280+288

AUTORIPARAZIONE



□ 114+122



□ 161+189



□ 150+156



□ 221+225



□ 239+251

UTENSILI PER MOTORIPARAZIONE



□ 252+256

UTENSILI PER BICICLETTA



Beta
bike tools

□ 257+260

UTENSILI A BATTERIA

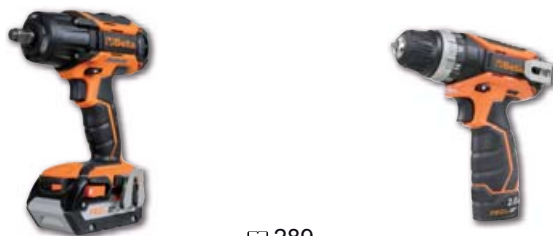

□ 289

UTENSILI PNEUMATICI E ACCESSORI



□ 290+312

UTENSILI ANTICADUTA



□ 268+274

PRODOTTI CHIMICI

 **Beta**
CHEMICALS



□ 498+502

PRODOTTI ABRASIVI

 **Beta**
ABRASIVES



□ 503+519

PRODOTTI A MARCHIO BM

 **BM**
GROUP



□ 520+525

ACCESSORI PER FUNI **ROBUR**



 **Robur**

□ 592+628

CALZATURE DI SICUREZZA (E CALZE TECNICHE)





□ 553+576

ABBIGLIAMENTO DA LAVORO





□ 577+591

SOLUZIONI PER IL **PUNTO VENDITA**





□ 540+552

GAMMA BLISTER



□ 526+539

BETA COLLECTION





□ 629+639

GUIDA ALLA LETTURA

numero articolo

42NEW

chiavi combinate

profilo utensile



prezzo unitario

DIN 3113 UNI-ISO-7738

★ articolo fornibile a richiesta

• misura principale

○ bocca esagonale

misura

numero utensili
nella confezione

numero utensili
nella serie

tipo confezione

contenuto
della serie

mm	L mm	S1 mm	€	
5,5	95	3,4	6,80	5 000421005
6	95	3,4	6,90	5 000421006
7	105	3,6	6,95	5 000421007
8	116	3,9	7,20	5 000421008
9	127	4,2	7,50	5 000421009
10	137	4,5	7,70	5 000421010
11	148	4,8	8,20	5 000421011
12	158	5,1	8,30	5 000421012
13	169	5,6	8,40	5 000421013
14	180	5,7	9,50	5 000421014
15	190	6,0	10,50	5 000421015
16	201	6,3	10,90	5 000421016
17	212	6,8	11,50	5 000421017
18	222	7,0	12,20	5 000421018
19	233	7,5	12,50	5 000421019

in confezione blister



utensili per motoripazione



utensili per biciclette



numero codice

novità 2021



42NEW/B9
6-7-8-10-11-13-14-17-19 mm € 87,00 1 000421064

Interpretazione delle sigle più correnti

Esempio

nelle serie		Esempio
B	= in busta di plastica	42NEW/B9
BV	= busta vuota	42NEW/BV9
C	= in cassetta	900/C11
D	= in confezione appendibile	1293/D6
S	= in scatola	42NEW/S17
SP	= con supporto	42MEW/SP25
SPV	= supporto vuoto	42NEW/SPV7
SC	= con supporto compatto	96/SC9
SCV	= supporto compatto vuoto	96/SCV

negli assortimenti

AS	= con chiavi in pollici	5915VU/AS
E	= versione Elettronica/Elettrotecnica	5980ET/A
I	= versione Idrraulica	5980ID
MT	= versione Movimento Terra	5902MT
U	= versione Universale	5915VU/3
SBK	= versione Motoriparazione	5940SBK
VG	= versione Autoriparatori	5904VG/5T
VI	= versione Industria	5902VI

nelle chiavi a bussola

A	= profilo esagonale	910A
B	= profilo poligonale	910B
ES	= profilo esascalato	920ES
FTX	= per viti TORX®	910FTX

Interpretazione delle sigle più correnti

Esempio

PT	= per viti pentalobate	910PT
X	= cricchetto reversibile nelle cassette	920A/C12X

nei giravite e inserti per avvitatori

LP	= per viti con intaglio	920LP
PE	= per viti con impronta esagonale	920PE
PH	= per viti con impronta PHILLIPS®	920PH
PZ	= per viti con impronta POZIDRIV® - SUPADRIV®	1299PZ
RTX	= per viti con impronta TAMPER RESISTANT TORX®	1298RTX
SP	= per viti con impronta SPANNER	861SP
TRW	= per viti con impronta TRI-WING®	861TRW
TQS	= per viti con impronta TORQ-SET®	861TQS
TX	= per viti con impronta TORX®	920TX
XZN	= per viti con impronta XZN®	920XZN

in generale

AS	= misure in pollici	42AS
BA	= utensili anticintilla	42BA
BM	= impugnatura bimatereale	1150BM
C	= contenitore metallico vuoto	C25
HS	= utensili anticaduta	42HS
INOX	= utensili acciaio inossidabile	42 INOX
L	= modello lungo	952L
MQ	= utensili isolati a 1000V	1150MQ
MP	= finitura lucida	42MP
R	= ricambio	338R

Le immagini riprodotte sono indicative.

Beta Utensili S.p.A. si riserva il diritto di apportare aggiornamenti e migliorie alla propria gamma produttiva senza preavviso.



Beta RACCOMANDA il corretto utilizzo degli utensili ed il rispetto delle disposizioni per la sicurezza individuale.



30

punzoni



Ø mm	L mm	€	📦	📄
2	125	6,00	10	000300020
3	125	6,00	10	000300030
4	150	8,00	10	000300040
5	150	8,00	10	000300050
6	150	8,40	10	000300060

31

cacciaspina



Ø mm	L mm	L1 mm	€	📦	📄
2	110	22	6,00	10	000310002
3	128	35	6,20	10	000310003
4	146	45	7,60	10	000310004
5	164	55	8,00	10	000310005
6	182	65	10,00	5	000310006
8	200	80	10,70	5	000310008
10	220	95	13,40	5	000310010



31/B6



31/SP6

31/B6	2-3-4-5-6-8 mm	55,00	1	000310020
42/BV6		6,30	1	000420051
31/SP6	2-3-4-5-6-8 mm	59,50	1	000310030
31/SPV		16,00	1	000310031

31BM

cacciaspina con impugnatura



Ø mm	L mm	L1 mm	€	📦	📄
2	168	42	12,30	2	000310402
3	180	52	12,60	2	000310403
4	191	62	13,80	2	000310404
5	200	72	14,50	2	000310405
6	221	82	16,70	2	000310406
8	235	94	17,50	2	000310408



31BM/D6	2-3-4-5-6-8 mm	87,50	1	000310420
---------	----------------	-------	---	-----------

31L

cacciaspina tipo lungo



Ø mm	L mm	L1 mm	€	📦	📄
4	175	80	9,00	5	000310104
5	175	80	9,50	5	000310105
6	175	80	11,50	5	000310106

31SE

cacciaspina per spine elastiche



Ø mm	D mm	L mm	L1 mm	€	📦	📄
4	2,4	175	80	9,00	5	000310204
5	3,0	175	80	9,50	5	000310205
6	3,6	175	80	11,50	5	000310206



31/B6-LSE		67,00	1	000310320
31L: 4-5-6 mm				
31SE: 4-5-6 mm				
55/BV6		7,00	1	000550151

32

bulini



Ø mm	L mm	L1 mm	€	📦	📄
3	100	44	5,60	10	000320100
4	125	52	6,90	10	000320125
5	150	62	8,40	10	000320150

32AU

bulino automatico

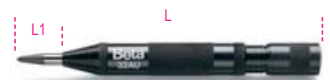

Ø mm	L mm	L1 mm	€	📦	📄
3	150	23	46,00	2	000320160

32AUR

punta di ricambio



Ø mm	€	📦	📄
3	8,20	5	000320170

34

scalpelli piatti



L mm	A mm	L1 mm	€	📦	📄
125	14,5	45	8,50	5	000340001
150	17,0	58	11,20	5	000340002
175	21,5	68	16,20	5	000340003

35

scalpelli nervati



L mm	A mm	€	📦	📄
100	14,5	9,90	5	000350001
125	17,0	11,20	5	000350002
150	20,5	13,90	5	000350003
200	23,0	21,10	5	000350004
250	28,5	30,50	2	000350005
300	34,0	41,00	2	000350006

35PM

scalpelli nervati con paramano



L mm	A mm	€	📦	📄
200	23,0	31,50	2	000350014
250	28,5	41,00	2	000350015
300	34,0	52,00	2	000350016

35PMR

ricambi paramano



L mm	€	📦	📄
200	10,50	1	000350024
250	10,50	1	000350025
300	11,00	1	000350026

36

ugnetti



L mm	A mm	L1 mm	€	Icona	Icona
125	4	44	8,90	5	000360001
150	6	53	10,50	5	000360002

37

ugnetti nervati



L mm	A mm	L1 mm	€	Icona	Icona
150	6	45	16,00	5	000370001
200	8	55	23,00	3	000370002

37PM

ugnetto nervato con paramano



L mm	A mm	€	Icona	Icona
200	8	34,00	2	000370012

37PMR

ricambio paramano



L mm	€	Icona	Icona
200	11,00	1	000370022



38/B6	55,50	1	000380006
30: 2-3 mm			
32: 4 mm			
34: 125-150 mm			
36: 150 mm			
42/BV6	6,30	1	000420051
38/SP6	60,00	1	000380009
30: 2-3 mm			
32: 4 mm			
34: 125-150 mm			
36: 150 mm			
38/SPV	16,00	1	000380019

42NEW

chiavi combinate



DIN 3113 UNI-ISO 7738

mm	L mm	S1 mm	€	Icona	Icona
5,5	95	3,4	6,80	5	000421005
6	95	3,4	6,90	5	000421006
7	105	3,6	6,95	5	000421007
8	116	3,9	7,20	5	000421008
9	127	4,2	7,50	5	000421009
10	137	4,5	7,70	5	000421010
11	148	4,8	8,20	5	000421011
12	158	5,1	8,30	5	000421012
13	169	5,6	8,40	5	000421013
14	180	5,7	9,50	5	000421014
15	190	6,0	10,50	5	000421015
16	201	6,3	10,90	5	000421016
17	212	6,8	11,50	5	000421017
18	222	7,0	12,20	5	000421018
19	233	7,5	12,50	5	000421019
20	243	7,7	14,20	3	000421020
21	254	7,9	15,30	3	000421021
22	264	8,3	15,70	3	000421022
23	275	8,5	17,00	3	000421023
24	285	8,7	18,00	3	000421024
25	296	8,7	19,00	2	000421025
26	307	8,9	20,50	2	000421026
27	317	9,1	22,30	2	000421027
28	328	9,3	23,00	2	000421028
29	338	9,5	24,80	2	000421029
30	349	9,7	26,00	2	000421030
32	370	10,1	29,00	2	000421032
34	391	10,5	54,50	1	000421034
35	412	10,7	58,50	1	000421035
36	412	10,7	61,00	1	000421036
38	433	11,3	67,50	1	000421038
41	465	12,0	76,00	1	000421041



42NEW/B9	87,00	1	000421064
6-7-8-10-11-13-14-17-19 mm			
42/BV9	8,00	1	000420056



42NEW/S14	142,00	1	000421067
6-7-8-10-11-12-13-14-15-16-17-19-22-24 mm			
42NEW/S17	173,50	1	000421065
6-7-8-9-10-11-12-13-14-15-16-17-18-19-20-21-22 mm			
42NEW/S15	198,00	1	000421066
6-7-8-10-11-12-13-14-17-19-22-24-27-30-32 mm			
42NEW/S17X	206,00	1	000421068
6-7-8-10-11-12-13-14-15-16-17-19-21-22-24-27-30 mm			
42NEW/S26	373,00	1	000421070
6-7-8-9-10-11-12-13-14-15-16-17-18-19-20-21-22-23-24-25-26-27-28-29-30-32 mm			

serie di 9 chiavi combinate con supporto compatto



42NEW/SC9I	90,50	1	000421087
8-10-11-12-13-14-15-17-19 mm			
42/SCV9I	8,50	1	000420103
42NEW/SC9E	94,00	1	000421088
8-10-11-12-13-16-17-18-19 mm			
42/SCV9E	8,50	1	000420104



42NEW/SP25	389,00	1	000421085
6-7-8-9-10-11-12-13-14-15-16-17-18-19-20-21-22-23-24-25-26-27-28-30-32 mm			
42/SPV2	41,00	1	000420090



42NEW/SP15	155,00	1	000421078
6-7-8-9-10-11-12-13-14-15-16-17-19-22-24 mm			
42/SPV7	6,00	1	000420097
42: 8-10-11-13-14-17-19 mm			
55: 6x7-8x9-10x11-12x13-14x15-16x17-18x19 mm			
42/SPV11	8,50	1	000420100
42MP: 8-9-10-11-12-13-14-15-16-17-19 mm			
142-142SN: 8-9-10-11-12-13-14-15-16-17-19 mm			
42/SPV15	11,50	1	000420102
42: 6-7-8-9-10-11-12-13-14-15-16-17-19-22-24 mm			

FINO AD ESAURIMENTO
SCORTE



DIN 3113 UNI-ISO 7738

mm	L mm	S1 mm	€		
5,5x5,5	95	3,4	6,80	5	000420005
6x6	95	3,4	6,90	5	000420006
7x7	105	3,6	6,95	5	000420007
8x8	116	3,9	7,20	5	000420008
9x9	127	4,2	7,50	5	000420009
10x10	137	4,5	7,70	5	000420010
11x11	148	4,8	8,20	5	000420011
12x12	158	5,1	8,30	5	000420012
13x13	169	5,4	8,40	5	000420013
14x14	180	5,7	9,50	5	000420014
15x15	190	6,0	10,50	5	000420015
16x16	201	6,3	10,90	5	000420016
17x17	212	6,7	11,50	5	000420017
18x18	222	7,0	12,20	5	000420018
19x19	233	7,3	12,50	5	000420019
20x20	243	7,6	14,20	3	000420020
21x21	254	7,9	15,30	3	000420021
22x22	264	8,1	15,70	3	000420022
23x23	275	8,3	17,00	3	000420023
24x24	285	8,5	18,00	3	000420024
25x25	296	8,7	19,00	2	000420025
26x26	307	8,9	20,50	2	000420026
27x27	317	9,1	22,30	2	000420027
28x28	328	9,3	23,00	2	000420028
29x29	338	9,5	24,80	2	000420029
30x30	349	9,7	26,00	2	000420030
32x32	370	10,1	29,00	2	000420032
34x34	391	10,5	54,50	1	000420034
35x35	412	10,7	58,50	1	000420035
36x36	412	10,9	61,00	1	000420036
38x38	433	11,3	67,50	1	000420038
41x41	465	12,0	76,00	1	000420041

42AS

chiavi combinate



mm	L mm	€		
1/4x1/4	95	8,10	2	000420106
9/32x9/32	106	8,20	2	000420107
5/16x5/16	116	8,30	2	000420108
3/8x3/8	137	9,20	2	000420110
7/16x7/16	148	9,70	2	000420111
1/2x1/2	169	10,10	2	000420113
9/16x9/16	180	11,00	2	000420114
19/32x19/32	191	12,10	2	000420115
5/8x5/8	201	12,80	2	000420116
11/16x11/16	212	13,80	2	000420117
3/4x3/4	233	14,60	2	000420119
13/16x13/16	254	17,60	2	000420121
7/8x7/8	264	18,20	2	000420122
15/16x15/16	285	21,20	2	000420124
1x1	296	22,00	2	000420125
1.1/16x1.1/16	317	25,00	2	000420127
1.1/8x1.1/8	338	27,00	2	000420129
1.1/4x1.1/4	370	33,00	2	000420132
1.5/16x1.5/16	391	54,50	1	000420133
1.3/8x1.3/8	412	62,00	1	000420135
1.7/16x1.7/16	412	64,00	1	000420136
1.1/2x1.1/2	433	68,00	1	000420138



42AS/B9	€		
1/4-5/16-3/8-7/16-1/2 9/16-5/8-11/16-3/4	105,50	1	000420155



42AS/13	€		
1/4-5/16-3/8-7/16-1/2-9/16-5/8 11/16-3/4-13/16-7/8-15/16-1	176,50	1	000420163
42AS/16	€		
1/4-5/16-3/8-7/16-1/2-9/16-5/8 11/16-3/4-13/16-7/8-15/16-1- 1.1/16-1.1/8-1.1/4	262,00	1	000420166
42AS/17	€		
1/4-9/32-5/16-3/8-7/16-1/2- 9/16-19/32-5/8-11/16-3/4- 13/16-7/8-15/16-1-1.1/16-1.1/8	249,00	1	000420168

42MP

chiavi combinate lucide



DIN 3113 UNI-ISO 7738

mm	L mm	€		
6x6	95	11,10	5	000420606
7x7	105	11,20	5	000420607
8x8	116	11,30	5	000420608
9x9	127	11,40	5	000420609
10x10	137	11,50	5	000420610
11x11	148	11,70	5	000420611
12x12	158	11,80	5	000420612
13x13	169	11,90	5	000420613
14x14	180	12,90	5	000420614
15x15	190	14,00	5	000420615
16x16	201	14,80	5	000420616
17x17	212	15,40	5	000420617
18x18	222	16,50	5	000420618
19x19	233	17,00	5	000420619
20x20	243	19,50	3	000420620
21x21	254	20,50	3	000420621
22x22	264	21,00	3	000420622
24x24	285	24,00	3	000420624
27x27	317	29,00	3	000420627
30x30	349	35,50	3	000420630
32x32	370	37,50	3	000420632



42MP/B9	€		
6-7-8-10-11-13-14-17-19 mm	122,00	1	000420651
42/BV9	€		
	8,00	1	000420056



42MP/S17	€		
6-7-8-9-10-11-12-13-14-15 16-17-18-19-20-21-22 mm	243,50	1	000420652
42MP/S21	€		
6-7-8-9-10-11-12-13-14 15-16-17-18-19-20-21-22 24-27-30-32 mm	369,00	1	000420653

42LMP

chiavi combinate lunghe lucide



mm	L mm	€		
8x8	148	10,70	2	000420508
9x9	167	10,90	2	000420509
10x10	172	11,40	2	000420510
11x11	186	11,90	2	000420511
12x12	197	12,20	2	000420512
13x13	207	12,40	2	000420513
14x14	223	13,30	2	000420514
15x15	233	14,50	2	000420515
16x16	243	15,60	2	000420516
17x17	261	16,60	2	000420517
18x18	270	18,10	2	000420518
19x19	280	18,60	2	000420519
21x21	301	21,50	2	000420521
22x22	318	22,10	2	000420522
24x24	338	25,50	2	000420524
27x27	376	29,50	2	000420527
30x30	394	37,50	2	000420530
32x32	435	41,00	2	000420532



42LMP/S14	€		
8-9-10-11-12-13-14 15-16-17-18-19-21-22 mm	210,00	1	000420551
42LMP/S18	€		
8-9-10-11-12-13-14 15-16-17-18-19-21-22 24-27-30-32 mm	344,00	1	000420552



42SLIM

chiavi combinate a testa ribassata



DIN 3113 UNI-ISO 7738

mm	L mm	S1 mm	€	U	IT
8x8	116	3,4	7,60	5	000420408
10x10	137	3,8	8,10	5	000420410
11x11	148	3,8	8,50	5	000420411
12x12	158	4,2	8,70	5	000420412
13x13	169	4,4	8,90	5	000420413
14x14	180	4,6	10,00	5	000420414
15x15	190	4,7	11,10	5	000420415
16x16	201	4,7	11,50	5	000420416
17x17	212	5,1	11,80	5	000420417
18x18	222	5,1	12,70	5	000420418
19x19	233	5,6	13,00	5	000420419



	€	U	IT
42SLIM/B8I 10-11-12-13-14-15-17-19 mm	88,00	1	000420468
42SLIM/B8E 10-11-12-13-16-17-18-19 mm	91,00	1	000420469
42SLIM/S11 8-10-11-12-13-14-15-16-17-18-19 mm	112,00	1	000420471

45

chiavi combinate tipo pesante



DIN 3113 UNI-ISO 7738

mm	L mm	€	U	IT
46x46	500	155,00	1	000450046
50x50	540	175,00	1	000450050
55x55	560	250,00	1	000450055
60x60	600	320,00	1	000450060
65x65	675	385,00	1	000450065
70x70	675	420,00	1	000450070
75x75	720	490,00	1	000450075
80x80	720	565,00	1	000450080

52

chiavi a forchetta semplici



UNI 6733 DIN 3114

mm	L mm	€	U	IT
10	119	8,10	5	000520010
11	119	8,30	5	000520011
12	119	8,60	5	000520012
13	145	9,60	5	000520013
14	145	9,80	5	000520014
15	145	10,10	5	000520015
16	159	10,90	5	000520016
17	159	11,00	5	000520017
18	159	11,80	5	000520018
19	175	12,80	5	000520019
20	175	13,80	5	000520020
21	175	14,10	5	000520021
22	196	15,80	2	000520022
23	196	16,40	2	000520023
24	196	16,70	2	000520024
25	215	18,80	2	000520025
26	215	19,10	2	000520026
27	215	19,20	2	000520027
28	240	22,50	2	000520028
30	240	23,00	2	000520030
32	270	27,00	2	000520032
34	270	30,00	1	000520034
35	295	34,00	1	000520035
36	295	34,00	1	000520036
38	295	38,50	1	000520038
40	335	47,00	1	000520040
41	335	47,00	1	000520041
42	335	51,50	1	000520042
45	370	59,50	1	000520045
46	370	59,50	1	000520046
48	370	69,00	1	000520048
50	415	80,00	1	000520050
52	415	89,50	1	000520052
55	415	93,00	1	000520055
60	490	118,00	1	000520060
65	490	120,00	1	000520065
70	490	136,00	1	000520070

53

chiavi a forchetta DIN 894



mm	L mm	€	U	IT
36	317	25,00	1	000530036
38	320	27,50	1	000530038
41	342	32,50	1	000530041
46	396	39,50	1	000530046
50	412	61,50	1	000530050
55	457	70,50	1	000530055
60	492	87,00	1	000530060
65	528	103,50	1	000530065
70	572	119,50	1	000530070
75	608	149,00	1	000530075
80	645	183,00	1	000530080
85	690	222,50	1	000530085
90	690	263,00	1	000530090
95	847	368,00	1	000530095
100	847	388,00	1	000530100
105	1000	485,00	1	000530105
110	1000	525,00	1	000530110
115	1000	585,00	1	000530115
120	1000	662,00	1	000530120
125	1000	765,00	1	000530125
130	1000	820,00	1	000530130
135	1000	880,00	1	000530135

55

chiavi a forchetta doppie



UNI-ISO 10102 DIN 3110

mm	L mm	€	U	IT
4x5	101	4,70	5	000550003
5x5,5	101	5,40	5	000550006
5,5x7	120	5,40	5	000550009
• 6x7	120	4,25	5	000550012
• 7x8	140	5,40	5	000550018
• 8x9	140	4,35	5	000550021
• 8x10	140	5,40	5	000550024
• 10x11	155	4,60	5	000550030
• 10x12	155	6,20	5	000550033
• 10x13	170	6,80	5	000550035
• 12x13	170	5,15	5	000550042
• 12x14	170	7,00	5	000550045
• 13x14	185	7,80	5	000550047
• 13x17	189	8,30	5	000550051
• 14x15	185	6,45	5	000550054
• 14x17	189	9,00	5	000550057
• 16x17	202	7,40	5	000550060
• 17x19	220	9,90	2	000550063
• 18x19	220	8,80	2	000550066
• 19x22	236	11,40	2	000550069
• 20x22	236	9,90	2	000550075
• 21x23	245	10,60	2	000550078
• 22x24	245	12,30	2	000550081
• 24x26	262	12,60	2	000550087
• 24x27	262	13,80	2	000550090
• 25x28	272	14,40	2	000550096
• 27x29	284	16,30	2	000550099
• 27x30	284	18,80	2	000550102
• 27x32	297	20,40	2	000550105
• 30x32	297	18,00	2	000550108
• 32x36	325	55,50	1	000550114
• 34x36	325	55,50	1	000550117
• 35x38	375	61,50	1	000550120
• 36x41	375	64,00	1	000550123
• 41x46	425	74,00	1	000550129
• 46x50	475	91,00	1	000550132
• 50x55	500	106,00	1	000550135
• 55x60	500	113,00	1	000550138



	€	U	IT
55/B8 6x7-8x9-10x11-12x13 14x15-16x17-18x19 20x22 mm	59,00	1	000550158
55/BV8	8,00	1	000550159
55/B12 6x7-8x9-10x11-12x13 14x15-16x17-18x19 20x22-21x23-24x26 25x28-30x32 mm	120,00	1	000550162
55/BV12	13,50	1	000550163

Beta

Beta



	€	🔧	📦
55/S8 6x7-8x9-10x11-12x13 14x15-16x17-18x19 20x22 mm	51,00	1	000550174
55/S12 6x7-8x9-10x11-12x13 14x15-16x17-18x19 20x22-21x23-24x26 25x28-30x32 mm	106,50	1	000550178
55/S12X 6x7-8x9-10x11-12x13 14x15-16x17-18x19 20x22-21x23-24x27 25x28-30x32 mm	107,50	1	000550179
55/S13 6x7-8x9-10x11-12x13 14x15-16x17-18x19 20x22-21x23-24x26 25x28-27x29-30x32 mm	123,00	1	000550182



	€	🔧	📦
55AS/5 5/16x11/32-3/8x7/16 1/2x9/16-5/8x11/16 3/4x7/8	44,00	1	000550290
55AS/8 1/4x9/32-5/16x11/32-3/8x7/16- 1/2x9/16-9/16x5/8-5/8x11/16- 11/16x13/16-3/4x7/8	70,50	1	000550296
55AS/12 1/4x9/32-5/16x11/32-3/8x7/16-1 /2x9/16-9/16x5/8-5/8x11/16- 11/16x13/16-25/32x13/16-3/4x7/8- 15/16x1-1x1.1/8-1.1/16x1.1/4	145,50	1	000550298

55MP chiavi a forchetta doppie lucide



UNI-ISO 10102 DIN 3110

🔧	L mm	€	🔧	📦
6x7	120	5,70	2	000550603
8x9	140	6,10	2	000550606
10x11	155	6,80	2	000550609
12x13	170	7,40	2	000550612
14x15	185	8,80	2	000550615
16x17	202	10,30	2	000550618
18x19	220	11,90	2	000550621
20x22	236	13,80	2	000550624
21x23	245	15,00	2	000550627
24x26	262	17,80	1	000550630
25x28	272	18,80	1	000550633
27x29	284	22,00	1	000550636
30x32	297	24,50	1	000550639



	€	🔧	📦
55MP/S8 6x7-8x9-10x11-12x13 14x15-16x17-18x19 20x22 mm	71,00	1	000550650
55MP/S13 6x7-8x9-10x11-12x13 14x15-16x17-18x19 20x22-21x23-24x26 25x28-27x29-30x32 mm	169,00	1	000550651
55MP/S12 6x7-8x9-10x11-12x13-14x15- 16x17-18x19-20x22-21x23-24x26- 25x28-30x32 mm	147,00	1	000550653



58 chiavi a forchetta a percussione



DIN 133

🔧	L mm	€	🔧	📦
24	177	25,50	1	000580024
27	180	27,00	1	000580027
30	190	30,00	1	000580030
32	190	31,50	1	000580032
34	200	39,50	1	000580034
36	215	40,50	1	000580036
41	235	48,00	1	000580041
46	255	64,00	1	000580046
50	275	72,00	1	000580050
55	300	86,50	1	000580055
60	320	95,00	1	000580060
65	342	124,00	1	000580065
70	375	160,00	1	000580070
75	375	175,00	1	000580075
80	408	255,00	1	000580080
85	408	285,00	1	000580085
90	445	330,00	1	000580090
95	445	340,00	1	000580095
100	485	470,00	1	000580100
105	485	530,00	1	000580105
110	510	580,00	1	000580110
115	510	660,00	1	000580115
120	545	680,00	1	000580120
125	545	780,00	1	000580125
130	575	1.050,00	1	000580130
135	575	1.110,00	1	000580135
*140	575	1.200,00	1	000580140
*145	640	1.645,00	1	000580145
*150	640	1.710,00	1	000580150
*155	640	1.870,00	1	000580155
*160	640	2.050,00	1	000580160
*165	715	2.200,00	1	000580165
*170	715	2.990,00	1	000580170
*175	715	3.160,00	1	000580175
*180	715	3.440,00	1	000580180
*185	715	3.530,00	1	000580185
*190	800	3.870,00	1	000580190
*195	800	4.080,00	1	000580195
*200	800	4.260,00	1	000580200
*210	800	5.320,00	1	000580210
*220	800	6.870,00	1	000580220
*230	800	8.380,00	1	000580230

73 chiavi a forchetta doppie piccole



UNI 6737

🔧	L mm	€	🔧	📦
4x4	78	7,20	5	000730040
4,5x4,5	78	7,20	5	000730045
5x5	78	7,20	5	000730050
5,5x5,5	86	7,80	5	000730055
6x6	86	7,80	5	000730060
7x7	86	7,80	5	000730070
8x8	97	8,10	5	000730080
9x9	97	8,10	5	000730090
10x10	108	8,80	5	000730100
11x11	108	8,80	5	000730110
12x12	124	10,10	5	000730120
13x13	124	10,10	5	000730130
14x14	124	10,10	5	000730140

55AS chiavi a forchetta doppie



🔧	L mm	€	🔧	📦
1/4x9/32	120	5,70	2	000550203
1/4x5/16	120	5,70	2	000550206
5/16x11/32	140	6,10	2	000550209
5/16x3/8	140	6,10	2	000550212
3/8x7/16	155	6,60	2	000550215
7/16x1/2	170	7,30	2	000550218
1/2x9/16	170	7,80	2	000550221
9/16x5/8	185	8,60	2	000550224
19/32x11/16	189	10,40	2	000550227
5/8x11/16	202	10,40	2	000550230
5/8x3/4	202	11,70	2	000550233
11/16x13/16	220	12,20	2	000550242
3/4x7/8	236	13,20	2	000550245
25/32x13/16	236	13,20	2	000550244
7/8x15/16	245	14,20	2	000550251
15/16x1	262	18,00	1	000550257
1x1.1/8	272	19,00	1	000550259
1.1/16x1.1/4	284	24,50	1	000550267
1.1/8x1.5/16	297	24,50	1	000550266
1.5/16x1.1/2	325	65,50	1	000550269
1.3/8x1.1/2	375	72,50	1	000550272
1.7/16x1.5/8	375	72,50	1	000550275



73/B13	€ 117,00	1	000730200
4-4,5-5-5,5-6-7-8-9			
10-11-12-13-14 mm			
73/BV	€ 7,80	1	000730201



73/S13	€ 109,00	1	000730210
4-4,5-5-5,5-6-7-8-9			
10-11-12-13-14 mm			

78

chiavi poligonali a percussione



DIN 7444

mm	L mm	€	Q	Icona
24	162	26,00	1	000780024
27	180	31,00	1	000780027
30	190	36,50	1	000780030
32	190	39,00	1	000780032
34	200	45,00	1	000780034
36	205	48,00	1	000780036
41	225	62,00	1	000780041
46	235	69,50	1	000780046
50	250	82,50	1	000780050
55	265	94,50	1	000780055
60	275	114,00	1	000780060
65	295	145,00	1	000780065
70	325	146,00	1	000780070
75	325	173,00	1	000780075
80	350	265,00	1	000780080
85	350	290,00	1	000780085
90	390	355,00	1	000780090
95	390	410,00	1	000780095
100	420	455,00	1	000780100
105	420	535,00	1	000780105
110	450	585,00	1	000780110
115	450	665,00	1	000780115
120	490	915,00	1	000780120
125	480	1.235,00	1	000780125
130	520	1.425,00	1	000780130
135	520	1.530,00	1	000780135
*140	520	1.740,00	1	000780140
*145	580	2.190,00	1	000780145
*150	580	2.290,00	1	000780150
*155	580	2.640,00	1	000780155
*160	650	2.710,00	1	000780160
*165	650	2.870,00	1	000780165
*170	650	3.450,00	1	000780170
*175	650	3.730,00	1	000780175
*180	650	4.090,00	1	000780180
*185	695	4.220,00	1	000780185
*190	695	4.620,00	1	000780190
*195	695	4.630,00	1	000780195
*200	695	4.700,00	1	000780200
*210	740	5.000,00	1	000780210
*215	740	5.600,00	1	000780215
*220	740	6.180,00	1	000780220
*230	740	7.650,00	1	000780230

78AS

chiavi poligonali a percussione



mm	L mm	€	Q	Icona
*1.1/16	180	37,50	1	000780327
*1.1/8	190	37,50	1	000780329
*1.3/16	190	37,50	1	000780330
*1.1/4	197	40,50	1	000780332
*1.5/16	197	41,50	1	000780333
*1.3/8	223	45,00	1	000780335
*1.7/16	223	54,00	1	000780336
*1.1/2	223	55,00	1	000780338
*1.5/8	223	63,00	1	000780341
*1.11/16	225	66,00	1	000780343
*1.13/16	240	73,00	1	000780346
*1.7/8	250	74,00	1	000780348
*2	250	84,00	1	000780350
*2.1/16	250	87,00	1	000780352
*2.3/16	275	91,50	1	000780355
*2.3/8	270	124,00	1	000780360
*2.9/16	302	138,00	1	000780365
*2.3/4	350	149,00	1	000780370
*2.15/16	350	172,50	1	000780375
*3.1/8	354	284,00	1	000780380

80

chiavi a bussola poligonale snodate doppie



mm	L mm	€	Q	Icona
6x7	170	29,50	3	000800006
8x9	176	30,00	3	000800008
8x10	179	30,00	3	000800009
10x11	182	32,00	3	000800010
12x13	228	36,00	3	000800012
14x15	232	36,50	3	000800014
13x17	231	39,00	3	000800015
16x17	234	39,00	2	000800016
18x19	285	48,00	2	000800018
19x22	287	50,00	2	000800019
20x22	289	50,00	2	000800020
21x23	289	51,00	2	000800021
24x27	405	84,00	2	000800024
30x32	413	89,00	2	000800030

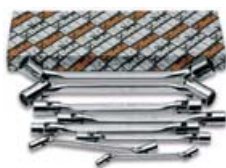

mm	L mm	€	Q	Icona
80/S8		301,00	1	000800051
6x7-8x9-10x11-12x13-14x15				
16x17-18x19-20x22 mm				
80/S11		525,00	1	000800056
6x7-8x9-10x11-12x13				
14x15-16x17-18x19-20x22				
21x23-24x27-30x32 mm				

83

chiavi poligonali per starter



ISO 3318

mm	L mm	€	Q	Icona
8x10	126	14,20	3	000830008
10x12	137	14,80	3	000830010
11x13	138	15,30	3	000830011
14x17	183	19,30	3	000830014
15x17	184	22,00	2	000830015
16x18	196	23,80	2	000830016
19x22	231	31,00	2	000830019



mm	L mm	€	Q	Icona
83/S3		65,50	1	000830081
11x13-14x17-19x22 mm				
83/S5		107,00	1	000830085
10x12-11x13-15x17				
16x18-19x22 mm				

83AS

chiavi poligonali per starter



mm	L mm	€	Q	Icona
7/16x1/2	138	18,30	2	000830111
9/16x5/8	183	21,70	2	000830114
3/4x7/8	230	34,50	2	000830119



mm	L mm	€	Q	Icona
83AS/S3		74,50	1	000830181
7/16x1/2-9/16x5/8				
3/4x7/8				

88

chiavi poligonali doppie diritte extralunghe



mm	L mm	€	Q	Icona
8x10	235	16,50	2	000880008
12x14	330	19,50	2	000880012
13x15	330	19,50	2	000880013
16x18	405	27,00	2	000880016
17x19	405	27,00	2	000880017
21x23	435	31,50	2	000880021
22x24	435	31,50	2	000880022



88/S7	€ 172,50	1	000880107
8x10-12x14-13x15-16x18-17x19-21x23-22x24 mm			

90

chiavi poligonali doppie curve



DIN 838 ISO 10104

mm	L mm	€		
6x7	165	8,10	5	000900006
8x9	180	8,70	5	000900012
8x10	180	10,20	5	000900015
10x11	195	9,50	5	000900018
10x12	195	10,40	5	000900021
11x13	215	11,50	5	000900024
12x13	215	10,50	5	000900027
12x14	215	12,00	5	000900030
14x15	230	11,50	5	000900033
14x17	250	14,20	5	000900036
16x17	250	13,10	5	000900039
17x19	265	16,90	5	000900042
18x19	265	15,20	5	000900045
19x22	285	19,00	3	000900048
20x22	285	17,50	3	000900051
21x23	305	19,80	2	000900057
22x24	305	21,50	2	000900060
24x26	325	22,30	2	000900063
24x27	325	24,40	2	000900067
25x28	340	26,50	2	000900070
27x29	355	29,00	2	000900073
27x30	355	31,50	2	000900076
27x32	375	34,50	2	000900078
30x32	375	32,50	2	000900080
32x36	395	48,00	1	000900088
34x36	415	57,00	1	000900089
35x38	415	58,00	1	000900091
36x41	435	66,00	1	000900094
41x46	460	95,00	1	000900097
46x50	500	125,00	1	000900100



90/B8	€ 105,00	1	000900154
6x7-8x9-10x11-12x13-14x15-16x17-18x19-20x22 mm			
90/BV8	€ 11,00	1	000900155



90/S8	€ 94,00	1	000900162
6x7-8x9-10x11-12x13-14x15-16x17-18x19-20x22 mm			

90/S12	€ 195,00	1	000900166
6x7-8x9-10x11-12x13-14x15-16x17-18x19-20x22-21x23-24x26-25x28-30x32 mm			

90/S12X	€ 197,50	1	000900167
6x7-8x9-10x11-12x13-14x15-16x17-18x19-20x22-21x23-24x27-25x28-30x32 mm			

90/S13	€ 224,00	1	000900170
6x7-8x9-10x11-12x13-14x15-16x17-18x19-20x22-21x23-24x26-25x28-27x29-30x32 mm			



90/SP13	€ 249,50	1	000900174
6x7-8x9-10x11-12x13-14x15-16x17-18x19-20x22-21x23-24x26-25x28-27x29-30x32 mm			
55/SPV	€ 25,50	1	000550190



90AS

chiavi poligonali doppie curve



mm	L mm	€		
1/4x5/16	165	9,40	2	000900203
5/16x11/32	180	10,00	2	000900206
5/16x3/8	180	10,30	2	000900209
3/8x7/16	195	10,50	2	000900212
7/16x1/2	215	11,80	2	000900215
1/2x9/16	230	13,50	2	000900218
9/16x5/8	230	13,50	2	000900221
19/32x11/16	250	14,70	2	000900222
5/8x11/16	250	15,20	2	000900224
5/8x3/4	265	18,00	2	000900227
11/16x3/4	265	18,00	1	000900230
11/16x13/16	265	18,00	1	000900233
3/4x25/32	265	20,80	1	000900235
3/4x7/8	285	20,80	1	000900237
13/16x7/8	285	21,20	1	000900240
7/8x15/16	305	21,20	1	000900243
15/16x1	325	25,50	1	000900252
1.1/16x1.1/4	375	37,50	1	000900258
1.1/8x1.5/16	375	38,00	1	000900261



90AS/8	€ 123,50	1	000900298
1/4x5/16-5/16x11/32-3/8x7/16-1/2x9/16-5/8x11/16-11/16x3/4-13/16x7/8-15/16x1			
90AS/10	€ 199,00	1	000900300
1/4x5/16-5/16x11/32-3/8x7/16-1/2x9/16-5/8x11/16-11/16x3/4-13/16x7/8-15/16x1-1.1/16x1.1/4-1.1/8x1.5/16			

91

chiavi poligonali curve



mm	Ø mm	€		
24	38	47,50	1	000910024
27	41	48,50	1	000910027
30	48	52,00	1	000910030
32	49	56,00	1	000910032
36	54	64,00	1	000910036
41	62	76,50	1	000910041
46	69	89,00	1	000910046
50	76	102,00	1	000910050
55	81	113,50	1	000910055
60	90	142,00	1	000910060
65	98	159,00	1	000910065
70	105	179,00	1	000910070
75	110	205,00	1	000910075
80	125	235,00	1	000910080
85	125	245,00	1	000910085
90	140	440,00	1	000910090
95	140	480,00	1	000910095
100	143	510,00	1	000910100
105	146	570,00	1	000910105

92

leve di manovra per art. 91



L mm	91 mm	Ø mm	€			
92/1	460	24÷30	19	28,50	1	000920010
92/2	610	32÷41	22	43,50	1	000920020
92/3	760	46÷55	25	61,50	1	000920030
92/4	860	60÷105	30	81,50	1	000920040

93

chiave per ponteggi



mm	L mm	€		
21x22	310	33,50	3	000930021

93C

chiavi a cricchetto per ponteggi



mm	L mm	€	Icon	Icon
17x19	310	39,00	1	000930117
19x22	310	42,00	1	000930119
19x24	310	51,00	1	000930120
21x22	365	47,50	1	000930121
36x38	445	79,00	1	000930136

94

chiavi per raccordi tubi



DIN 3118

mm	L mm	€	Icon	Icon
8x10	140	14,20	2	000940008
9x11	153	14,80	2	000940009
10x11	153	15,50	2	000940010
11x13	175	16,00	2	000940011
12x14	175	17,00	2	000940012
13x15	175	17,00	2	000940013
14x15	175	20,00	2	000940014
14x17	195	20,50	2	000940015
17x19	212	21,00	2	000940017
19x22	228	22,50	2	000940019
22x24	242	27,50	2	000940022
24x27	260	30,00	2	000940024
30x32	300	39,00	2	000940030
36x41	320	66,50	1	000940036



94/S6 106,00 1 000940050

8x10-10x11-11x13-12x14
17x19-19x22 mm

94/S10 217,50 1 000940052

8x10-9x11-10x11-11x13
12x14-17x19-19x22
22x24-24x27-30x32 mm

95

chiavi poligonali doppie diritte



DIN 837 ISO 10103

mm	L mm	€	Icon	Icon
6x7	120	9,30	3	000950161
8x9	135	9,90	3	000950162
10x11	150	11,30	3	000950163
12x13	165	12,30	3	000950164
14x15	185	12,90	3	000950165
16x17	210	13,80	3	000950166
17x19	225	15,80	3	000950167
18x19	225	15,80	2	000950168
20x22	240	18,00	2	000950169
21x23	255	19,00	2	000950170
24x26	270	20,00	2	000950171
25x28	285	24,20	2	000950172
27x29	315	24,70	2	000950173
30x32	335	27,50	2	000950174



95/S8 103,50 1 000950177

6x7-8x9-10x11-12x13
14x15-16x17-18x19
20x22 mm

95/S13 219,00 1 000950179

6x7-8x9-10x11-12x13
14x15-16x17-18x19
20x22-21x23-24x26
25x28-27x29-30x32 mm

95FTX

chiavi doppie diritte per viti
con teste a profilo Torx®



	L mm	€	Icon	Icon
E6xE8	115	9,50	2	000950306
E10xE12	143	10,00	2	000950310
E14xE18	177	11,50	2	000950314
E20xE24	224	15,50	2	000950320



95FTX/S4 46,50 1 000950325

E6xE8-E10xE12
E14xE18-E20xE24

96

chiavi maschio esagonale piegate
cromate



ISO 2936

mm	L mm	L1 mm	€	Icon	Icon
0,9	35	8	0,82	20	000960013
1,3	39	10	0,82	20	000960014
1,5	45	15	0,82	20	000960015
2	50	17	0,88	20	000960020
2,5	57	20	0,88	20	000960025
3	64	22	1,02	20	000960030
3,5	68	25	1,22	20	000960035
4	72	28	1,27	20	000960040
4,5	78	30	1,32	20	000960045
5	83	32	1,37	20	000960050
5,5	88	35	1,72	20	000960055
6	94	37	1,72	20	000960060
7	99	40	2,13	10	000960070
8	105	43	2,50	10	000960080
9	111	46	2,95	10	000960090
10	119	49	3,50	10	000960100
11	126	52	4,45	10	000960110
12	134	56	5,30	10	000960120
13	142	62	6,75	10	000960130
14	151	69	7,90	10	000960140
16	165	75	11,60	5	000960160
17	174	79	12,20	5	000960170
19	196	88	17,00	5	000960190

mm	L mm	L1 mm	€	Icon	Icon
22	216	100	26,50	3	000960220
24	242	112	35,00	1	000960240
27	271	125	47,00	1	000960270
30	309	140	62,50	1	000960300
32	341	155	82,50	1	000960312
36	385	174	119,00	1	000960316



96/ST6 12,20 3 000960370

2,5-3-4-5-6-8 mm



96/BGS7 26,00 1 000960367

1,5-2-2,5-3-4-5-6 mm



96/BG7 28,00 1 000960368

2,5-3-4-5-6-8-10 mm



96/B8 14,70 5 000960386

2-2,5-3-4-5-6-8-10 mm

96/B10 20,90 5 000960380

1,5-2-2,5-3-4-5-6-8-10-12 mm

96N/BV 1,60 1 000960651



96/SC9 17,60 1 000960374

1,5-2-2,5-3-4-5-6-8-10 mm

96/SCV 3,60 1 000960985





96/SC12	€ 25,00	1	000960395
2-2,5-3-3,5-4-4,5-5			
6-7-8-9-10 mm			
96/SCV12	€ 4,30	1	000960975

96N

chiavi maschio esagonale piegate
brunite



ISO 2936

mm	L mm	L1 mm	€	🔧	📦
0,9	32	10	0,41	20	000960409
1,3	44	12	0,41	20	000960413
1,5	46	15	0,43	20	000960415
2	51	17	0,45	20	000960420
2,5	57	20	0,47	20	000960425
3	64	22	0,53	20	000960430
3,5	68	25	0,64	20	000960435
4	72	28	0,73	20	000960440
4,5	78	30	0,80	20	000960445
5	83	32	0,83	20	000960450
6	94	37	1,04	20	000960460
7	99	40	1,39	10	000960470
8	105	43	1,65	10	000960480
9	111	46	2,15	10	000960490
10	119	49	2,55	10	000960500
11	126	52	3,15	10	000960510
12	134	56	3,85	10	000960520
13	142	62	5,10	10	000960530
14	151	69	5,80	10	000960540
16	165	72	8,70	5	000960560
17	174	79	9,40	5	000960570
19	194	88	12,60	5	000960590
22	216	99	23,50	1	000960592
24	242	111	31,00	1	000960594



96N/ST6	€ 8,65	3	000960640
2,5-3-4-5-6-8 mm			



96N/G7	€ 21,80	3	000960645
2,5-3-4-5-6-8-10 mm			
96N/G7A	€ 15,20	3	000960643
1,5-2-2,5-3-4-5-6 mm			



96N/B10	€ 14,10	5	000960650
1,5-2-2,5-3-4-5-6			
8-10-12 mm			
96N/BV	€ 1,60	1	000960651



96N/SC9	€ 12,30	1	000960644
1,5-2-2,5-3-4-5-6-8-10 mm			
96N/SCV	€ 3,60	1	000960986



96N/SC12	€ 17,50	1	000960661
2-2,5-3-3,5-4-4,5-5			
6-7-8-9-10 mm			
96N/SCV12	€ 4,30	1	000960976

96C/AS

chiavi maschio esagonale piegate
cromate



"	L mm	L1 mm	g	€	🔧	📦
1/16	46	16	1,01	1,45	20	000961702
3/32	53	19	2,70	2,00	20	000961706
1/8	60	22	5,33	2,10	20	000961710
5/32	67	25	9,33	2,45	20	000961714
3/16	74	28	14,87	2,80	20	000961716
7/32	81	32	22,00	3,15	20	000961718
1/4	89	35	31,40	3,50	20	000961720
5/16	103	40	56,16	3,95	10	000961724
3/8	117	45	91,31	4,80	10	000961728



96C-AS/SC9	€ 30,00	1	000961753
1/16-3/32-1/8-5/32-3/16-			
7/32-1/4-5/16-3/8			

96AS

chiavi maschio esagonale piegate
brunite



"	L mm	L1 mm	€	🔧	📦
1/30 (0,035")	44	14	0,74	20	000960698
1/20 (0,050")	44	15	0,74	20	000960701
1/16	46	16	0,80	20	000960702
5/64	50	18	0,97	20	000960704
3/32	53	19	1,12	20	000960706
7/64	57	21	1,16	20	000960708
1/8	60	22	1,17	20	000960710
9/64	64	24	1,40	20	000960712
5/32	68	25	1,45	20	000960714
3/16	75	29	1,60	20	000960716
7/32	82	32	1,80	20	000960718
1/4	89	35	2,10	20	000960720
5/16	103	40	2,62	10	000960724
3/8	117	44	3,20	10	000960728
7/16	132	49	4,65	10	000960730
1/2	149	54	5,85	10	000960732
9/16	151	69	9,50	2	000960734
5/8	165	72	11,60	1	000960736
3/4	194	88	19,20	1	000960738



96AS/SC9	€ 19,50	1	000960743
1/16-3/32-1/8-5/32-3/16			
7/32-1/4-5/16-3/8			
96AS/SCV	€ 3,60	1	000960744



96AS/T7	€ 16,20	3	000960740
3/32-1/8-5/32			
3/16-7/32-1/4-5/16			



96AS/G7	€ 22,50	3	000960745
3/32-1/8-5/32			
3/16-1/4-5/16-3/8			



96AS/BG7	€ 28,00	1	000960747
3/32-1/8-5/32-3/16			
1/4-5/16-3/8			



96AS/B11	€ 19,20	1	000960749
1/20-1/16-5/64-3/32			
1/8-5/32-3/16-7/32			
1/4-5/16-3/8			
96N/BV	€ 1,60	1	000960651

96LC

chiavi maschio esagonale piegate
tipo lungo, cromate



ISO 2936

mm	L mm	L1 mm	€		
2	101	17	1,57	20	000960320
2,5	113	20	1,67	20	000960321
3	127	22	1,82	20	000960322
3,5	138	25	1,87	20	000960323
4	142	28	2,03	20	000960324
4,5	154	28	2,38	20	000960325
5	163	32	2,58	20	000960326
6	184	37	2,78	20	000960327
7	194	40	3,20	10	000960328
8	205	43	3,95	10	000960329
9	216	46	4,35	10	000960330
10	231	49	5,60	10	000960331
12	259	56	6,95	10	000960332



96LC/SC8	€ 25,50	1	000960334
2-2,5-3-4-5-6-8-10 mm			
96LC/SCV	€ 3,60	1	000960983



96LC/SC12	€ 38,00	1	000960337
2-2,5-3-3,5-4-4,5-5-6-7-8-9-10 mm			
96LC/SCV12	€ 4,30	1	000960977

96L

chiavi maschio esagonale piegate
tipo lungo, brunite



ISO 2936

mm	L mm	L1 mm	€		
2	99	15	1,10	20	000960820
2,5	110	17	1,15	20	000960825
3	124	19	1,30	20	000960830
3,5	135	21	1,40	20	000960835
4	138	24	1,55	20	000960840
4,5	150	25	1,80	20	000960845
5	158	27	1,90	20	000960850
6	178	31	2,15	20	000960860
7	187	33	2,75	10	000960870
8	197	35	3,45	10	000960880
9	207	37	3,90	10	000960890
10	221	39	5,15	10	000960900
12	247	44	6,70	10	000960920



96L/SC8	€ 21,40	1	000960924
2-2,5-3-4-5-6-8-10 mm			
96L/SCV	€ 3,60	1	000960987



96L/SC12	€ 32,00	1	000960929
2-2,5-3-3,5-4-4,5-5-6-7-8-9-10 mm			
96L/SCV12	€ 4,30	1	000960978

96BP-CL

chiavi maschio esagonale piegate
con estremità sferica, cromate
colorate



mm	L mm	L1 mm	€		
1,5	91	16	2,45	5	000961600
2	102	17	2,75	5	000961601
2,5	113	21	3,05	5	000961602
3	128	23	3,35	5	000961603
4	143	28	3,75	5	000961604
5	163	33	4,05	5	000961605
6	185	37	5,20	5	000961606
8	206	43	7,10	2	000961608
10	231	50	9,40	2	000961610



96BP-CL/SC9	€ 44,50	1	000961619
1,5-2-2,5-3-4-5-6-8-10 mm			
96BP-CL/SCV	€ 3,60	1	000961629

96BPC

chiavi maschio esagonale piegate
con estremità sferica, cromate



mm	L mm	L1 mm	€		
1,5	79	13	1,85	10	000960340
2	84	15	1,95	10	000960341
2,5	89	17	2,05	10	000960342
3	99	19	2,20	10	000960343
4	108	24	2,50	10	000960344
5	126	27	3,05	10	000960345
6	148	31	4,35	10	000960346
7	157	33	5,70	5	000960353
8	168	35	5,80	5	000960347
10	187	39	9,40	5	000960348
12	220	55	12,00	5	000960352



96BPC/SC9	€ 36,50	1	000960354
1,5-2-2,5-3-4-5-6-8-10 mm			
96BPC/SCV	€ 3,60	1	000960984

96BP

chiavi maschio esagonale
piegate con estremità sferica, brunite



mm	L mm	L1 mm	€		
1,5	79	13	1,40	10	000960960
2	84	15	1,50	10	000960961
2,5	89	17	1,55	10	000960962
3	99	19	1,60	10	000960963
4	108	24	1,85	10	000960965
5	126	27	2,45	10	000960967
6	148	31	3,50	10	000960968
8	168	35	5,00	5	000960970
10	187	39	8,60	5	000960972
12	220	55	12,70	5	000960973





96BP/SC9	€ 31,00	1	000960974
1,5-2-2,5-3-4-5-6-8-10 mm			
96BP/SCV	3,60	1	000960988

96LBP

chiavi maschio esagonale piegate con estremità sferica, modello extralungo, cromate



mm	L mm	L1 mm	€		
1,5	90	15	2,15	5	000961340
2	100	17	2,25	5	000961341
2,5	112	20	2,40	5	000961342
3	127	22	2,50	5	000961343
4	144	27	3,10	5	000961344
5	163	32	3,70	5	000961345
6	184	37	5,05	5	000961346
8	204	44	7,00	2	000961348
10	230	49	11,10	2	000961350



96LBP/SC9	€ 43,00	1	000961354
1,5-2-2,5-3-4-5-6-8-10 mm			
96LBP/SCV	3,60	1	000961984

96BP/AS

chiavi maschio esagonale piegate con estremità sferica, brunite

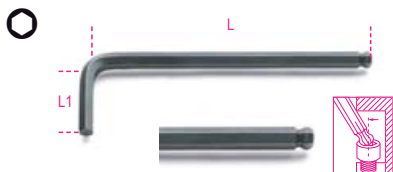

"	L mm	L1 mm	€		
3/32	89	17	1,70	10	000960989
1/8	98	18	1,80	10	000960990
5/32	108	24	2,15	10	000960991
3/16	126	26	2,45	10	000960992
7/32	139	28	3,55	10	000960993
1/4	152	31	3,90	10	000960994
5/16	168	34	5,10	5	000960995
3/8	190	39	8,50	5	000960996



96BP-AS/SC9	€ 33,50	1	000961000
1/16-3/32-1/8-5/32-3/16			
7/32-1/4-5/16-3/8			
96BP-AS/SCV	3,60	1	000961001



96BP-AS/8	€ 30,50	1	000960997
3/32-1/8-5/32-3/16-7/32			
1/4-5/16-3/8			
96BP-AS/BV	1,60	1	000960998

96BPA

chiavi maschio esagonale piegate a 110° con estremità sferica, modello lato extra corto, cromate



mm	L mm	L1 mm	€		
1,5	71	9	2,00	5	000961960
2	86	11	2,10	5	000961961
2,5	96	13	2,20	5	000961962
3	104	15	2,40	5	000961963
4	116	17	2,90	5	000961964
5	132	19	3,40	5	000961965
6	155	21	4,90	5	000961966
8	176	24	6,60	2	000961968
10	200	27	10,20	2	000961970



96BPA/SC9	€ 40,50	1	000961974
1,5-2-2,5-3-4-5-6-8-10 mm			
96BPA/SCV	3,60	1	000961988



96T

chiavi maschio esagonale piegate con impugnatura di manovra

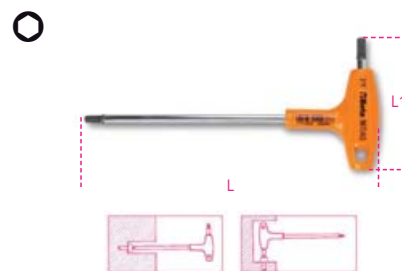

mm	L mm	L1 mm	€		
2	139	52	9,50	5	000960934
2,5	153	55	9,50	5	000960935
3	153	55	10,00	5	000960936
3,5	179	70	10,40	5	000960937
4	179	70	10,40	5	000960938
4,5	200	84	10,70	5	000960939
5	200	84	10,70	5	000960940
6	221	103	12,20	5	000960941
7	236	106	13,40	3	000960942
8	255	117	15,50	3	000960943
10	285	132	17,90	3	000960945



96T/S6	€ 62,50	1	000960952
2-2,5-3-4-5-6 mm			
96T/S8	95,50	1	000960933
2-2,5-3-4-5-6-8-10 mm			
96T/S11	130,00	1	000960951
2-2,5-3-3,5-4-4,5-5-6-7-8-10 mm			



96T/SP11	€ 141,00	1	000960957
2-2,5-3-3,5-4-4,5-5			
6-7-8-10 mm			
96T/SPV	14,50	1	000960958
96T/S11			
97TTX/S11			

96T/AS

chiavi maschio esagonale piegate
con impugnatura di manovra

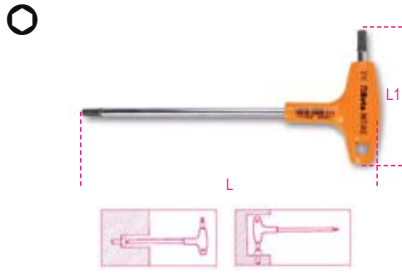

"	L mm	L1 mm	€	📦	🚚
3/32	153	55	11,90	2	000960669
7/64	153	55	11,90	2	000960670
1/8	179	70	12,10	2	000960671
9/64	179	70	12,60	2	000960672
5/32	200	84	12,60	2	000960673
3/16	200	84	12,60	2	000960674
7/32	221	103	14,10	2	000960675
1/4	236	106	15,70	2	000960676
5/16	255	117	17,90	2	000960678
3/8	285	132	21,20	2	000960680



96T/AS8	116,00	1	000960682
3/32-7/64-1/8-5/32-3/16-1/4-5/16-3/8			
96T/AS10	142,50	1	000960683
3/32-7/64-1/8-9/64-5/32-3/16-7/32-1/4-5/16-3/8			

96TBP

chiavi maschio esagonale piegate
con estremità sferica ed impugnatura
di manovra



mm	L mm	L1 mm	€	📦	🚚
2,5	153	55	10,00	3	000960685
3	153	55	10,60	3	000960686
4	179	70	11,10	3	000960687
5	200	84	11,60	3	000960688
6	221	103	12,60	3	000960689
8	255	117	16,80	2	000960690
10	285	132	17,90	2	000960692



96TBP/S6	72,50	1	000960694
2,5-3-4-5-6-8 mm			

97TX

chiavi maschio piegate
per viti con impronta Torx®



	L mm	L1 mm	€	📦	🚚
T6	42	16	5,40	5	000970006
T7	48	16	5,40	5	000970007
T8	48	16	5,40	5	000970008
T9	48	16	5,90	5	000970009
T10	51	17	6,00	5	000970010
T15	54	18	6,00	5	000970015
T20	57	19	6,40	5	000970020
T25	60	20	6,60	5	000970025
T27	64	21	7,20	5	000970027
T30	70	24	7,20	5	000970030
T40	76	26	8,00	5	000970040
T45	83	29	9,50	5	000970045
T50	95	32	10,90	5	000970050
T55	108	35	14,00	5	000970055
T60	120	38	18,50	5	000970060



97TX/ST8	58,50	1	000970640
T9-T10-T15-T20-T25-T27-T30-T40			



97TX/G8	46,00	1	000970645
T9-T10-T15-T20-T25-T27-T30-T40			



97TX/BG8	36,00	1	000970368
T9-T10-T15-T20-T25-T27-T30-T40			



97TX/SC8	57,00	1	000970064
T9-T10-T15-T20-T25-T27-T30-T40			
97TX/SCV	3,60	1	000970985



97TX/B13	91,50	1	000970650
T6-T7-T8-T9-T10-T15-T20-T25-T27-T30-T40-T45-T50			
96N/BV	1,60	1	000960651

97BTX

chiavi maschio piegate
con un'estremità sferica
per viti con impronta Torx®

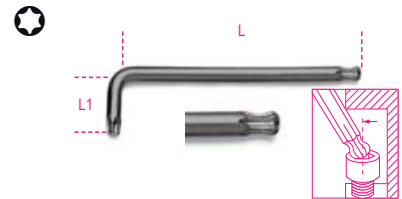

	L mm	L1 mm	€	📦	🚚
T9	80	16	6,85	5	000970109
T10	86	17	6,85	5	000970110
T15	90	18	6,85	5	000970115
T20	95	19	7,35	5	000970120
T25	100	20	7,85	5	000970125
T27	105	21	8,35	5	000970127
T30	114	24	8,45	5	000970130
T40	124	26	9,60	5	000970140
T45	133	28	11,40	5	000970145
T50	152	32	12,70	3	000970150
T55	164	35	18,20	3	000970155



97BTX/SC8	65,50	1	000970164
T9-T10-T15-T20-T25-T27-T30-T40			
97BTX/SCV	3,60	1	000970983



97BTX/B8	63,50	1	000970159
T9-T10-T15-T20-T25-T27-T30-T40			
96N/BV	1,60	1	000960651



97BTX-C

chiavi maschio piegate con un'estremità sferica per viti con impronta Torx® colorate



	L mm	L1 mm	€	📦	📄
T9	80	16	7,60	5	000971609
T10	86	17	7,60	5	000971610
T15	90	18	7,60	5	000971615
T20	95	19	8,20	5	000971620
T25	100	20	8,80	5	000971625
T27	105	21	9,30	5	000971627
T30	114	24	9,50	5	000971630
T40	124	26	10,60	5	000971640



	€	📦	📄
97BTX-C/SC8	73,00	1	000971658
T9-T10-T15-T20-T25-T27-T30-T40			
97BTX-C/SCV	3,60	1	000971659

97BTXL

chiavi maschio piegate con un'estremità sferica, modello lungo, per viti con impronta Torx®



	L mm	L1 mm	€	📦	📄
T9	80	15	7,20	3	000970309
T10	86	17	7,20	3	000970310
T15	100	18	7,20	3	000970315
T20	110	19	8,20	3	000970320
T25	126	20	9,10	3	000970325
T27	140	24	10,10	3	000970327
T30	160	28	10,60	3	000970330
T40	176	32	12,50	3	000970340



	€	📦	📄
97BTXL/SC8	75,50	1	000970364
T9-T10-T15-T20-T25-T27-T30-T40			
97BTXL/SCV	3,60	1	000970982

97RTX

chiavi maschio piegate con viti con impronta Tamper Resistant Torx®



	L mm	L1 mm	€	📦	📄
T6	40	15	6,50	5	000970206
T7	45	15	6,50	5	000970207
T8	50	16	6,50	5	000970208
T9	56	16	6,50	5	000970209
T10	62	17	6,50	5	000970210
T15	72	17	6,50	5	000970215
T20	83	18	6,70	5	000970220
T25	90	18	6,90	5	000970225
T27	100	20	7,70	5	000970227
T30	105	24	7,80	5	000970230
T40	112	26	8,60	5	000970240
T45	118	26	10,00	5	000970245
T50	122	28	13,00	3	000970250
T55	128	30	15,00	3	000970255



	€	📦	📄
97RTX/SC8	61,00	1	000970263
T9-T10-T15-T20-T25-T27-T30-T40			
97RTX/SCV	3,60	1	000970984



	€	📦	📄
97RTX/B8	59,00	1	000970260
T9-T10-T15-T20-T25-T27-T30-T40			
96N/BV	1,60	1	000960651

97TTX

chiavi maschio piegate con impugnatura per viti con impronta Torx®

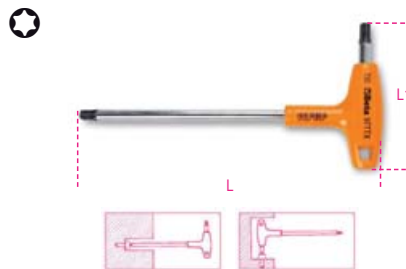

	L mm	L1 mm	€	📦	📄
T6	130	52	9,80	3	000970706
T7	130	52	9,80	3	000970707
T8	139	52	9,90	3	000970708
T9	139	52	9,90	3	000970709
T10	179	70	10,20	3	000970710
T15	179	70	11,00	3	000970715
T20	179	70	11,50	3	000970720
T25	179	70	12,20	3	000970725

	L mm	L1 mm	€	📦	📄
T27	200	84	13,40	3	000970727
T30	200	84	13,90	3	000970730
T40	221	103	16,50	3	000970740
T45	236	106	19,30	2	000970745
T50	255	117	24,50	2	000970750



	€	📦	📄
97TTX/S6	75,50	1	000970791
T10-T15-T20-T25-T30-T40			
97TTX/S8	98,50	1	000970808
T8-T9-T10-T15-T20-T25-T27-T30-T40			
97TTX/S11	152,50	1	000970800
T8-T9-T10-T15-T20-T25-T27-T30-T40-T45-T50			
97TTX/S13	172,00	1	000970813
T6-T7-T8-T9-T10-T15-T20-T25-T27-T30-T40-T45-T50			



	€	📦	📄
97TTX/SP11	163,50	1	000970840
T8-T9-T10-T15-T20-T25-T27-T30-T40-T45-T50			
96T/SPV	14,50	1	000960958
96T/S11			
97TTX/S11			

98XZN

chiavi a profilo XZN®



DIN 65253

	L mm	L1 mm	€	📦	📄
M5	83	25	4,65	5	000980005
M6	89	30	5,35	5	000980006
M8	97	32	6,75	5	000980008
M10	106	35	8,85	5	000980010
M12	116	37	11,20	5	000980012
M14	118	45	14,20	5	000980014
M16	125	45	21,00	5	000980016



	€	📦	📄
98XZN/B5	38,50	1	000980650
M5-M6-M8-M10-M12			
96N/BV	1,60	1	000960651

99

chiavi a settore con nasello quadro per ghiere



UNI 6752

mm	A mm	€		
12-14	1,5	9,00	3	000990012
16-18-20	1,8	9,00	3	000990016
22-25-28	1,8	11,90	3	000990022
30-32	2,1	11,90	3	000990030
34-36-38	2,4	14,50	3	000990034
40-42	2,4	14,50	3	000990040
45-50	2,5	18,00	3	000990045
52-55-58	2,5	18,00	3	000990052
62-65	3,1	23,00	3	000990062
68-70-75	3,1	23,00	3	000990068
80-85-90	3,8	30,50	2	000990080
92-95	4,3	30,50	2	000990092
98-100	4,3	30,50	2	000990098
105-110-115	4,4	48,00	1	000990105
120-125-130	4,9	48,00	1	000990120
135-145	6,0	71,00	1	000990135
155-165	6,0	71,00	1	000990155

99SQ

chiavi a settore articolate con nasello quadro



mm	B mm	€		
15-35	2,7	24,00	2	000990215
35-50	3,5	27,50	2	000990235
50-80	4,7	36,00	2	000990250
80-120	6,2	49,50	2	000990280
120-180	7,8	66,00	2	000990290

99ST

chiavi a settore articolate con nasello tondo



mm	Ø mm	B mm	€		
15-35	3,0	2,5	24,50	2	000990315
35-50	4,0	4,5	29,50	2	000990335
50-80	5,0	5,0	39,00	2	000990350
80-120	6,0	7,0	53,00	2	000990380
120-180	8,0	9,0	69,00	2	000990390

99 VN/...

nasello di ricambio per 99ST

mm	€		
99ST VN/15	15-35	6,80	1 000990295
99ST VN/35	35-50	7,80	1 000990296
99ST VN/50	50-80	9,50	1 000990297
99ST VN/80	80-120	11,00	1 000990298
99ST VN/120	120-180	14,50	1 000990299

100

chiave a compasso con naselli tondi



Ø mm	L mm	Ø min-max mm	€		
4,9-5,9	250	18÷100	127,00	1	001000001
6,9-7,9					

100/KIT

naselli di ricambio per art. 100



100/KIT	€		
	39,00	1	001000010

111

chiavi regolabili a rullino cromate con scala graduata

- Rotazione destrorsa del rullino
- Scala in millimetri e in pollici



DIN 3117 ISO 6787

L mm	L" "	A max mm	€		
100	4	15	19,90	3	001110010
150	6	24	20,70	3	001110015
200	8	28	24,90	3	001110020
250	10	34	31,00	3	001110025
300	12	35	41,00	3	001110030
380	15	45	80,00	3	001110038
450	18	54	133,00	2	001110045
600	24	62	184,00	1	001110060

111N

chiavi regolabili a rullino fosfatate con scala graduata

- Rotazione sinistrorsa del rullino
- Con scala in millimetri e in pollici



DIN 3117 ISO 6787

L mm	L" "	A max mm	€		
100	4	15	18,30	3	001110210
150	6	24	19,30	3	001110215
200	8	28	22,50	3	001110220
250	10	34	28,00	3	001110225
300	12	35	38,00	3	001110230
380	15	45	74,00	3	001110238
450	18	54	126,00	2	001110245

111G

chiavi regolabili a rullino con scala graduata cromate con impugnatura

- Rotazione destrorsa del rullino
- Scala in millimetri e in pollici
- Impugnatura ergonomica



DIN 3117 ISO 6787

L mm	L" "	A max	€		
200	8	28	30,50	3	001110620
250	10	34	37,50	3	001110625
300	12	35	49,00	2	001110630

120

chiavi poligonali aperte a cricchetto

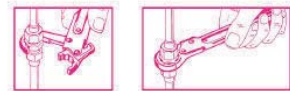

mm	L mm	€		
10	135	40,00	1	001200010
11	135	40,00	1	001200011
12	135	40,00	1	001200012
13	135	40,00	1	001200013
14	135	46,00	1	001200014
17	185	49,00	1	001200017
19	185	52,00	1	001200019
22	230	71,00	1	001200022
24	230	76,00	1	001200024
27	230	96,50	1	001200027
30	320	110,00	1	001200030
32	320	115,50	1	001200032



120/B6	€		
10-11-13	300,00	1	001200050
17-19-22 mm			
120/BV	8,50	1	001200051

123E1/4

adattatore portainserti 1/4" per chiavi a cricchetto 10 mm



mm	L mm	€		
10	20,6	5,40	1	001230010

123Q1/4

adattatore a sgancio rapido 1/4"
per chiavi a cricchetto 10 mm



Ø mm	L mm	€	🔧	📦
10	17,5	7,50	1	001230310

123Q3/8

adattatore a sgancio rapido 3/8"
per chiavi a cricchetto 13 mm



Ø mm	L mm	€	🔧	📦
13	22,5	7,60	1	001230313

123Q1/2

adattatore a sgancio rapido 1/2"
per chiavi a cricchetto 19 mm

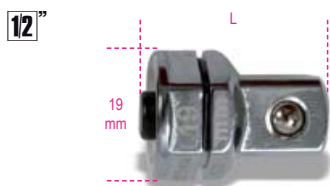

Ø mm	L mm	€	🔧	📦
19	30,5	8,00	1	001230319

123/K4

kit di 4 adattatori per chiavi a cricchetto:
1 adattatore per bits
3 adattatori a sgancio rapido



123/K4	€	🔧	📦
	28,50	1	001230504

141

chiavi combinate diritte
a cricchetto



Ø mm	L mm	€	🔧	📦
8x8	136	13,50	3	001410008
9x9	143	14,10	3	001410009
10x10	160	14,50	3	001410010
11x11	168	14,80	3	001410011
12x12	174	15,40	3	001410012
13x13	180	16,70	3	001410013
14x14	193	17,40	2	001410014
15x15	200	18,20	2	001410015
16x16	216	19,90	2	001410016
17x17	233	20,70	2	001410017
18x18	239	21,50	2	001410018
19x19	250	22,00	2	001410019



141/B6	€	🔧	📦
8-10-13-14-17-19 mm	112,50	1	001410066



141/S12	€	🔧	📦
8-9-10-11-12-13-14-15-16-17-18-19 mm	208,50	1	001410072

142

chiavi combinate a cricchetto reversibile



Ø mm	L mm	€	🔧	📦
6x6	136	14,80	3	001420006
7x7	136	14,80	3	001420007
8x8	136	15,30	3	001420008
9x9	143	16,30	3	001420009
10x10	159	16,80	3	001420010
11x11	168	17,30	3	001420011
12x12	174	17,90	3	001420012
13x13	180	19,30	3	001420013
14x14	190	19,90	2	001420014
15x15	200	21,10	2	001420015
16x16	216	22,80	2	001420016
17x17	233	23,20	2	001420017
18x18	239	25,00	2	001420018
19x19	248	25,50	2	001420019
21x21	285	33,50	1	001420021
22x22	285	34,50	1	001420022
24x24	325	40,50	1	001420024
27x27	355	58,00	1	001420027
30x30	420	68,00	1	001420030
32x32	420	70,50	1	001420032
34x34	482	98,00	1	001420034
36x36	482	99,00	1	001420036
38x38	482	101,00	1	001420038



142/B6	€	🔧	📦
8-10-13-14-17-19 mm	127,50	1	001420066
142/BV6	7,50	1	001420076
142/B9	185,50	1	001420069
8-10-11-12-13-14-15-17-19 mm			
142/BV9	9,00	1	001420079



142/S15	€	🔧	📦
6-7-8-9-10-11-12-13-14-15-16-17-18-19-22 mm	305,00	1	001420074
142/S17	420,00	1	001420068
6-7-8-10-11-12-13-14-15-16-17-18-19-21-22-24-27 mm			
142/S19	541,00	1	001420075
6-7-8-9-10-11-12-13-14-15-16-17-18-19-22-24-27-30-32 mm			

142/SC9I-E

serie di 9 chiavi combinate a cricchetto
reversibile con supporto compatto



142/SC9I	€	🔧	📦
8-10-11-12-13-14-15-17-19 mm	183,00	1	001420087
142/SCV9I	8,50	1	001420103
142/SC9E	190,00	1	001420088
8-10-11-12-13-16-17-18-19 mm			
142/SCV9E	8,50	1	001420104



142MC

chiavi combinate a cricchetto reversibile colorate



mm	L mm	€		
8x8	136	16,00	3	001422008
10x10	159	17,50	3	001422010
11x11	168	18,00	3	001422011
12x12	174	18,80	3	001422012
13x13	180	20,20	3	001422013
14x14	190	21,00	2	001422014
15x15	200	22,00	2	001422015
16x16	216	24,00	2	001422016
17x17	233	24,50	2	001422017
18x18	239	26,00	2	001422018
19x19	248	27,00	2	001422019



	€		
142MC/SC9I 8-10-11-12-13-14-15-17-19 mm	192,00	1	001422087
142MC/SC9E 8-10-11-12-13-16-17-18-19 mm	199,00	1	001422088

142AS

chiavi combinate a cricchetto reversibile



mm	L mm	€		
5/16x5/16	136	18,00	2	001420308
3/8x3/8	159	18,50	2	001420310
7/16x7/16	168	19,50	2	001420311
1/2x1/2	180	21,80	2	001420313
9/16x9/16	190	22,30	2	001420314
5/8x5/8	216	24,50	2	001420316
11/16x11/16	233	25,00	2	001420317
3/4x3/4	248	28,00	2	001420319



	€		
142AS/8 5/16-3/8-7/16-1/2 9/16-5/8-11/16-3/4	177,50	1	001420330

142C

chiavi combinate corte diritte a cricchetto



mm	L mm	€		
8x8	88	11,00	2	001420108
9x9	96	11,00	2	001420109
10x10	96	11,50	2	001420110
11x11	100	12,20	2	001420111
12x12	104	12,90	2	001420112
13x13	108	13,50	2	001420113
14x14	114	14,10	2	001420114
15x15	118	14,60	2	001420115
16x16	122	15,10	2	001420116
17x17	128	16,30	2	001420117
18x18	132	17,50	2	001420118
19x19	138	18,00	2	001420119



	€		
142C/A12 8-9-10-11-12-13-14 15-16-17-18-19 mm	189,50	1	001420175

142SN

chiavi combinate a cricchetto snodate



mm	L mm	€		
7x7	136	17,70	2	001420207
8x8	136	18,50	2	001420208
9x9	143	19,20	2	001420209
10x10	160	20,30	2	001420210
11x11	168	21,20	2	001420211
12x12	174	21,90	2	001420212
13x13	180	23,20	2	001420213
14x14	193	24,00	2	001420214
15x15	200	25,50	2	001420215
16x16	216	27,50	2	001420216
17x17	233	28,00	2	001420217
18x18	239	30,00	2	001420218
19x19	250	30,50	2	001420219
22x22	285	36,00	1	001420222
24x24	325	40,50	1	001420224



	€		
142SN/S13 7-8-9-10-11-12-13-14 15-16-17-18-19 mm	307,00	1	001420263

186

chiave autoserrante a ripresa automatica per esagoni da 8 a 32 mm

ideale per viti con testa a profilo: esagonale, Spline(R), quadrato, Torx(R); anche rovinate.



L mm	€		
260	42,00	1	001860008

187

chiavi esagonali apribili snodate



mm	L mm	€		
8x9	125	28,00	1	001870008
10x11	155	30,00	1	001870010
12x13	175	31,00	1	001870012
14x15	205	34,00	1	001870014
16x17	235	38,50	1	001870016



	€		
187/B5 8x9-10x11-12x13 14x15-16x17 mm	170,50	1	001870050

188

chiavi poligonali diritte e a cricchetto per pulegge libere alternatori



mm	L mm	€		
10	240	19,00	2	001880010
15	322	26,00	2	001880015

192

chiavi poligonali doppie diritte a cricchetto reversibile 4 in 1



mm	L mm	€		
8x10/12x13	160	24,00	1	001920008
16x17/18x19	230	31,50	1	001920016



192/S2
8x10/12x13 mm
16x17/18x19 mm
€ 55,50 1 001920070

194
chiave portainseri a cricchetto
reversibile



1/4x5/16 L mm
128 € 31,50 2 001940006

195
chiavi poligonali doppie diritte a cricchetto



mm	L mm	€		
8x10	128	17,00	2	001950010
12x13	170	19,50	2	001950013
14x15	190	20,50	2	001950015
16x18	230	23,70	2	001950018
17x19	230	25,00	2	001950019



195/B5
8x10-12x13-14x15
16x18-17x19 mm
195/BV5
€ 114,50 1 001950066
9,00 1 001950070

195AS
chiavi poligonali doppie diritte a cricchetto



mm	L mm	€		
5/16x3/8	128	17,50	2	001950606
7/16x1/2	170	19,50	2	001950611
9/16x5/8	190	22,00	2	001950614
11/16x3/4	230	24,50	2	001950617



195AS/B4
5/16x3/8 - 7/16x1/2 -
9/16x5/8 - 11/16x3/4
195FTX/BV4
€ 92,50 1 001950654
9,00 1 001950520

195P
chiavi poligonali doppie piegate a 15°
a cricchetto reversibile



mm	L mm	€		
8x10	128	25,50	2	001950210
12x13	170	27,50	2	001950213
14x15	190	28,50	2	001950215
16x18	230	32,00	2	001950218
17x19	230	33,50	2	001950219



195P/B5
8x10-12x13-14x15
16x18-17x19 mm
195/BV5
€ 156,00 1 001950266
9,00 1 001950070

310
polifusori per saldatura tubi e raccordi
in materiale plastico PE, PP, PVC e PVDF

CE



230V-650 Watt
50 Hz±60Hz
Schuko (CEE 7/7)

Ø mm	€		
310/1 16÷50	225,00	1	003100001
310/2 16÷63	315,00	1	003100002

310B
matrici per polifusore 310



Ø mm	€		
16	54,00	1	003100016
20	59,50	1	003100020
25	63,00	1	003100025
32	70,00	1	003100032
40	82,50	1	003100040
50	104,00	1	003100050
63	120,00	1	003100063

310/C4
polifusore con assortimento
di 3 matrici



310/C4
310/1+310B: Ø 20-25-32
€ 452,00 1 003100104
410x260x82 mm - 4,8 kg

310/C8
polifusore con assortimento
di 7 matrici



310/C8
310/2+310B: Ø 16-20-25
32-40-50-63
€ 708,00 1 003100108
440x270x120 mm - 7,7 kg

311
termopiastre per saldatura tubi
in materiale plastico PE, PP, PVC e PVDF

CE



230V
50 Hz±60Hz
Schuko (CEE 7/7)

Ø mm	Watt	€		
311/1 120	300	280,00	1	003110001
311/2 190	900	311,00	1	003110002

330
tagliatubi per tubi gas in acciaio



Ø mm - "	L mm	€		
330/2 10÷60 1/8"÷ 2"	380	131,00	1	003300002
330/4 60÷115 2"÷ 4"	585	299,00	1	003300004



330R/A

coltelli di ricambio per 330
per tubi in acciaio

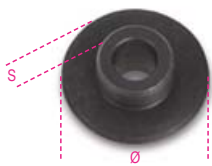

	Ø mm	S mm	€	Icon	Icon
330R/A2	32	7	12,50	1	003300012
330R/A4	42	9	33,00	1	003300014

330R/I

coltello di ricambio per 330
per acciaio INOX



	Ø mm	S mm	€	Icon	Icon
330R/I2	32	7	28,50	1	003300024
330R/I4	32	9	79,00	1	003300034

331L

tagliatubi a cricchetto
per rame e leghe leggere



	Ø mm - "	L mm	€	Icon	Icon
8÷29		180	59,50	1	003310008
5/16"÷1"1/8					

331LR/L

coltello di ricambio per tagliatubi 331L



	Ø mm	€	Icon	Icon
331LR/L	18	5,70	1	003310058

332

mini-tagliatubi per rame
e leghe leggere



	Ø mm - "	L mm	€	Icon	Icon
3÷16		59	19,00	2	003320001
1/8"÷5/8"					

334

tagliatubi per rame e leghe leggere



	Ø mm - "	L mm	€	Icon	Icon
3÷30		150	26,00	1	003340001
1/8"÷1"1/8					

334R

coltello di ricambio per 332-334
per rame e leghe leggere



	Ø mm	€	Icon	Icon
334R	18	5,60	1	003340021

334R/I

coltello di ricambio per 332-334
per acciaio inox



	Ø mm	€	Icon	Icon
334R/I	18	15,80	1	003340023

336

tagliatubi ad avanzamento telescopico
per rame e leghe leggere



	Ø mm - "	L mm	€	Icon	Icon
6÷38		160	43,50	1	003360001
1/4"÷1"1/2					

338

tagliatubi ad avanzamento telescopico
rapido per rame, leghe leggere e plastica



	Ø mm - "	L mm	€	Icon	Icon
6÷67		290	107,50	1	003380001
1/4"÷2"5/8					

338R

coltello di ricambio per 331L, 336 e 338
per rame e leghe leggere



	Ø mm	€	Icon	Icon
338R	18,5	5,90	1	003380022

338R/I

coltello di ricambio per 336 e 338
per acciaio inox



	Ø mm	€	Icon	Icon
338R/I	21,8	17,50	1	003380023

338RP

coltello di ricambio per 336 e 338
per plastica



	Ø mm	€	Icon	Icon
338RP	21,9	6,40	1	003380025

339A

tagliatubi ad avanzamento telescopico
rapido per tubi di plastica



	Ø mm - "	L mm	€	Icon	Icon
50÷127		345	229,00	1	003390011
2"÷5"					

339A/R

coltelli di ricambio per 339A

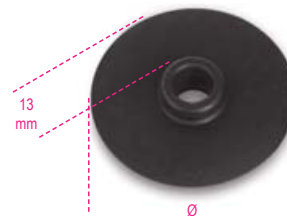

	Ø mm	€	Icon	Icon
339A/R	42	15,80	1	003390061

340

pinza tagliatubi per tubi multistrato

lama rivestita in PTFE

4 rulli di appoggio per facilitare la rotazione del tubo durante il taglio

sistema per il taglio dei tubi corrugati integrato nel manico

corpo leggero in magnesio



Ø max mm	€	1	003400001
26	89,00		

340RL

lama di ricambio per 340



340RL	€	1	003400010
	25,00		

341

pinza tagliatubi per tubi in materiale plastico



Ø mm	L mm	€	1	003410001
0÷25	190	32,00		

341RL

lama di ricambio per 341



341RL	€	1	003410010
	13,40		

341B

cesoia a cricchetto per tubi in materiale plastico



Ø mm	L mm	€	1	003410051
0÷35	195	58,50		

341B/RM

molla di ricambio per 341B

341B/RM	€	1	003410061
	2,20		

341B/RL

lama di ricambio per 341B



341B/RL	€	1	003410060
	21,00		

342

cesoia a cricchetto per tubi in materiale plastico



Ø mm - "	L mm	€	1	003420030
0÷50 1"5/8	200	43,00		

342MOL

molla di ricambio per 342

342MOL	€	1	003420033
	3,10		

342RL

lama di ricambio per 342



342RL	€	1	003420032
	19,50		

342A

cesoia a cricchetto per tubi in materiale plastico



Ø mm - "	L mm	€	1	003420101
0÷50 2"	270	87,50		

342A/MOL

molla di ricambio per 342A

342A/MOL	€	1	003420111
	1,90		

342A/RL

lama di ricambio per 342A



342A/RL	€	1	003420110
	46,00		

342P

cesoia a cricchetto in lega di magnesio per tubi in materiale plastico



Ø mm - "	L mm	€	1	003420121
0÷50 2"	260	95,00		

342P/RL

lama di ricambio per 342P



342P/RL	€	1	003420130
	39,50		

345

utensile sbavatubi corpo in metallo

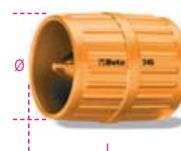

Ø mm - "	L mm	€	5	003450001
3÷42 1/8"÷1"5/8	58	23,50		



345U

utensile sbavatubi per inox, acciaio, rame e leghe leggere



Ø mm -"	L mm	€	📦	🚚
4+36 5/32+1"7/16	60	62,00	1	003450050

345C

calibratore per tubi multistrato



Ø mm	€	📦	🚚
16-20-26-32	37,50	1	003450032

345SB

sbavatore a raschietto a lama intercambiabile girevole



L mm	€	📦	🚚
150	19,30	5	003450010

345SB/R

lama di ricambio per 345SB



345SB/R	€	📦	🚚
	6,80	3	003450015

349

attrezzo bordatubi con frizione per rame e leghe leggere

38"



Ø mm -"	€	📦	🚚
6-8-10-12-14-15-16-18 (1/8-3/16-1/4-5/16 3/8-1/2-5/8-3/4)	232,00	1	003490001

270x200x50 mm - 2,7 kg

349/SMM

slitta metrica per 349



Ø mm	€	📦	🚚
6-8-10-12-14-15-16-18	68,00	1	003490011

349/SMAS

slitta in pollici per 349



Ø "	€	📦	🚚
1/8-3/16-1/4-5/16 3/8-1/2-5/8-3/4	64,00	1	003490012

350

attrezzo bordatubi per rame e leghe leggere



Ø mm	L mm	A mm	€	📦	🚚
4-4,75-6-8 10-12-14	175	104	67,50	1	003500001

351C

tagliatubi ed attrezzo bordatubi



351C	€	📦	🚚
	122,00	1	003510010

334	Ø 3+30 mm (1/8"+1"1/8)
350	Ø 4+14 mm
351P	Ø 4-4,75-6-8-10-12-14 mm

225x150x45 mm - 1,6 kg

351P

puntali per 350



	Ø mm	€	📦	🚚
351P 4	4	5,60	3	003510101
351P 4,75	4,75	5,60	3	003510102
351P 6	6	5,60	3	003510103
351P 8	8	5,60	3	003510104
351P 10	10	5,60	3	003510105
351P 12	12	5,60	3	003510106
351P 14	14	5,60	3	003510107

352U

attrezzo bordatubi regolabile, per rame e leghe leggere

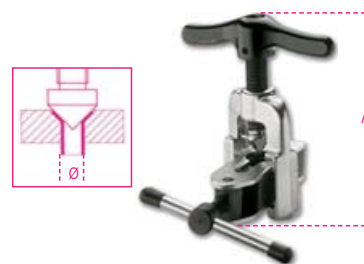

Ø mm -"	A mm	€	📦	🚚
5+16 3/16+5/8	130	80,00	1	003520101

352C/U

tagliatubi, sbavatore ed attrezzo bordatubi regolabile



352C/U	€	📦	🚚
	155,50	1	003520110

334 Ø 3+30 mm (1/8"+1"1/8)

345SB

352U Ø 5+16 mm (3/16"+5/8")

335x145x60 mm - 2120 g

353N

pinza allargatubi a matrici ad espansione, intercambiabili



L mm	€	📦	🚚
380	313,00	1	003530201

353NM

matrici ad espansione per 353N



Ø mm	A mm	€		
10	7	107,00	1	003530210
12	10	107,00	1	003530212
14	10	107,00	1	003530214
16	12	107,00	1	003530216
18	12	107,00	1	003530218
22	13	107,00	1	003530222

353N/C6

pinza allargatubi 353N
con matrici ad espansione 353NM



353N/C6	€		
	990,00	1	003530300

353N
353NM Ø 10-12-14-16-18-22 mm
420x185x60 mm - 2,2 kg

355

chiave per raccordi radiatori
a cinque gradazioni

12"



Ø "	L mm	€		
3/8"-1/2"	90	32,00	2	003550001
3/4"-1"				

357F3

dima a tre file
per installazione attacchi sanitari

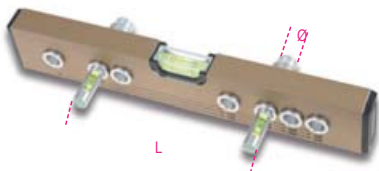

Ø "	L mm	€		
3/8" / 1/2"	90=220	101,00	1	003570100

357R/F3

fiala di ricambio per 357F3



357R/F3	€		
	16,30	1	003570101

358

attrezzi per smussare esternamente
tubi in materiale plastico



358/1	Ø mm	€		
	16÷110	142,00	1	003580001
358/2	40÷250	142,00	1	003580002

358RL

lama di ricambio per 358/1 e 358/2



358RL	€		
	26,00	1	003580011

359

chiave universale per pilette



Ø "	L mm	A mm	€		
1"÷1"1/4	160	140	70,00	1	003590001

359CH

adattatore per pilette
con grata a croce per 359



Ø "	L mm	€		
1"1/2	74	39,50	1	003590005

360

giratubi modello stillson



L mm	Ø max "	Ø max mm	€		
250	1" gas	34	30,50	1	003600025
350	1"1/2 gas	49	40,00	1	003600035
450	2" gas	60	55,50	1	003600045
600	2"1/2 gas	76	85,00	1	003600060
900	3"1/2 gas	102	235,00	1	003600090

360R/...

kit ricambio per 360
composto da ganascia mobile e ghiera.

360R250	€		
	11,20	1	003600225
360R350	15,30	1	003600235
360R450	21,90	1	003600245
360R600	33,00	1	003600260
360R900	59,00	1	003600290

362

giratubi modello americano



L mm	Ø max "	Ø max mm	€		
200	1" gas	34	26,00	1	003620020
250	1"1/2 gas	49	33,50	1	003620025
300	2" gas	60	39,50	1	003620030
350	2" gas	60	47,50	1	003620035
450	2"1/2 gas	76	68,00	1	003620045
600	3" gas	90	103,00	1	003620060
900	5" gas	140	127,00	1	003620090

362R/...

kit ricambi per 362
composto da: ganascia fissa; ganascia mobile;
ghiera; spina di fissaggio.

362R 200	€		
	5,50	1	003620220
362R 250	7,80	1	003620225
362R 300	9,60	1	003620230
362R 350	11,20	1	003620235
362R 450	15,20	1	003620245
362R 600	20,30	1	003620260
362R 900	50,50	1	003620290

363

giratubi modello americano
corpo in lega leggera



L mm	Ø max " gas	Ø max mm	€		
350	2" gas	60	57,50	1	003630035
450	2 1/2" gas	76	76,50	1	003630045
600	3" gas	90	129,50	1	003630060
900	5" gas	140	242,00	1	003630090
1200	6" gas	165	257,00	1	003630120

363R/...

kit ricambi per 363

composto da: ganaschia fissa; ganaschia mobile;
ghiera; spina di fissaggio.

	€		
363R 350	12,20	1	003630235
363R 450	16,30	1	003630245
363R 600	22,40	1	003630260
363R 900	45,00	1	003630290
363R 1200	68,50	1	003630320

365

giratubi modello frontale
corpo in lega leggera



L mm	Ø max " gas	Ø max mm	€		
350	2" gas	60	71,50	1	003650035
450	2 1/2" gas	76	98,00	1	003650045

365R/...

kit ricambi per 365

composto da: ganaschia fissa; ganaschia mobile;
ghiera; spina di fissaggio.

	€		
365R 350	53,50	1	003650235
365R 450	79,50	1	003650245

366

giratubi tipo leggero



L mm	Ø max " gas	Ø max mm	€		
175	1" gas	34	26,50	1	003660017
225	1 1/2" gas	49	32,50	1	003660022
275	2" gas	60	38,50	1	003660027
300	2 1/2" gas	76	42,00	1	003660030
350	3" gas	90	47,50	1	003660035

374

giratubi modello svedese
ganasce sottili a 45°



DIN 5234

L mm	Ø max " gas	Ø max mm	€		
240	1/2" gas	21	31,50	1	003740024
320	1" gas	34	42,00	1	003740032
410	1 1/2" gas	49	55,00	1	003740041
550	2" gas	60	86,00	1	003740055
630	3" gas	90	153,00	1	003740063

375

giratubi modello svedese
ganasce parallele a 45°



DIN 5234

L mm	Ø max " gas	Ø max mm	€		
320	1" gas	34	42,00	1	003750032
410	1 1/2" gas	49	55,00	1	003750041
550	2" gas	60	86,00	1	003750055

376

giratubi modello svedese
ganasce piane a 90°



DIN 5234

L mm	Ø max " gas	Ø max mm	€		
320	1" gas	34	42,00	1	003760032
410	1 1/2" gas	49	55,00	1	003760041
550	2" gas	60	86,00	1	003760055
630	3" gas	90	155,00	1	003760063

378

giratubi modello svedese
ganasce sottili a 45°



DIN 5234

L mm	Ø max " gas	Ø max mm	€		
250	1/2" gas	21	33,50	1	003780025
320	1" gas	34	44,50	1	003780032
410	1 1/2" gas	49	57,50	1	003780041
550	2" gas	60	94,00	1	003780055
650	3" gas	90	158,00	1	003780065

374R/...

KIT ricambi completi per 374 - 375 - 376 - 378
composto da ghiera e fermaghiera

	€		
374R 240 374/240-378/250	1,85	1	003740724
374R 320 374/320-375/320-376/320-378/320	2,05	1	003740732
374R 410 374/410-375/410-376/410-378/410	2,25	1	003740741
374R 550 374/550-375/550-376/550-378/550	3,05	1	003740755
374R 630 374/630-378/650	4,60	1	003740763

383

giratubi reversibili a nastro



	Ø max " gas	Ø max mm	L mm	€		
383/1	3" gas	90	300	45,50	1	003830001
383/2	8" gas	220	300	47,50	1	003830002

383R

nastri di ricambio per 383



	S mm	€		
383R/1	27	18,20	1	003830010
383R/2	27	19,20	1	003830015

384

giratubi reversibile a catena



	Ø max " gas	Ø max mm	L mm	€		
384	4" gas	115	300	61,00	1	003840032

384RC

catena di ricambio per 384



	€		
384RC	37,50	1	003840033

386A

giratubi reversibili a catena
modello pesante



	∅ max	L mm	€		
386A/3	4" gas 115 mm	900	205,00	1	003860003
386A/4	6" gas 168 mm	900	379,00	1	003860004
386A/5	8" gas 220 mm	1100	490,00	1	003860005
386A/6	12" gas 324 mm	1300	850,00	1	003860006

386A/RC

catene di ricambio per 386A



	€		
386A3/RC	63,50	1	003860013
386A4/RC	91,00	1	003860014
386A5/RC	121,00	1	003860015
386A6/RC	212,00	1	003860016

388

attrezzi curvatubi
per rame, lega leggera



∅ mm	L mm	R mm	€		
6	305	18,0	49,50	1	003880006
8	315	23,5	54,00	1	003880008
10	350	31,0	62,00	1	003880010
12	360	31,0	66,00	1	003880012
14	455	46,5	86,00	1	003880014
15	465	46,5	91,00	1	003880015
16	465	46,5	98,00	1	003880016

388A

pinza curvatubi
per rame e lega leggera



	∅ mm	L mm	€		
388A/1	6-8-10 mm	220	54,00	1	003880051
388A/2	1/4"-5/16"-3/8"	220	54,50	1	003880055

388C/C8

attrezzo curvatubi con 7 matrici
per rame e lega leggera



	∅ mm	€		
388C/C8	10-12-14-16 18-20-22	394,00	1	003880200

400x330x110 mm - 3,6 kg

392C

pinza regolabile per sifoni



∅ mm	L mm	€		
25÷65	260	37,50	1	003920100

392RG/C

coppia di copri ganasce di ricambio per 392C



	€		
392RG/C	5,10	1	003920101

393

pinza per dadi rubinetto



L mm	€		
270	54,50	1	003930001

395

chiave per dadi rubinetto
articolata



∅	L mm	€		
15÷32 mm 5/8"÷1"1/4	240	35,50	1	003950001

395T

chiave per dadi rubinetto
articolata, telescopica



∅	L mm	€		
10÷32 mm 3/8"÷1"1/4	250÷430	48,00	1	003950100

399

morse ribaltabili da banco



∅	L min mm	€		
10÷60 mm 1/8÷2"	220	151,50	1	003990005
10÷89 mm 1/8÷3"	290	273,00	1	003990010

399R/...

kit ricambio per 399
composto da due ganasce inferiori e
una superiore



	€		
399RG1/8-2"	18,00	1	003990105
399RG1/8-3"	29,50	1	003990110



410

punte elicoidali cilindriche
serie corta, in acciaio HSS
rullate

R ≤ 650 N/mm²
HV ≈ 750÷820



DIN 338 ISO 235

Ø mm	L mm	L1 mm	€	🔧	📦
0,50	22	6	1,30	10	004100030
1,00	34	12	0,72	10	004100040
1,25	38	16	0,60	10	004100043
1,50	40	18	0,56	10	004100046
1,75	46	22	0,56	10	004100049
2,00	49	24	0,50	10	004100052
2,25	53	27	0,60	10	004100055
2,50	57	30	0,56	10	004100058
2,75	61	33	0,60	10	004100061
3,00	61	33	0,56	10	004100064
3,20	65	36	0,75	10	004100066
3,25	65	36	0,75	10	004100067
3,50	70	39	0,70	10	004100070
3,75	70	39	0,85	10	004100073
4,00	75	43	0,78	10	004100076
4,20	75	43	0,96	10	004100078
4,25	75	43	0,96	10	004100079
4,50	80	47	0,88	10	004100082
4,75	80	47	1,00	10	004100085
5,00	86	52	0,95	10	004100088
5,25	86	52	1,36	10	004100091
5,50	93	57	1,27	10	004100094
5,75	93	57	1,40	10	004100097
6,00	93	57	1,27	10	004100100
6,25	101	63	1,67	10	004100103
6,50	101	63	1,57	10	004100106
6,75	109	69	2,00	10	004100109
7,00	109	69	1,85	10	004100112
7,50	109	69	1,95	10	004100118
8,00	117	75	2,30	10	004100124
8,50	117	75	2,42	10	004100130
9,00	125	81	2,98	5	004100136
9,50	125	81	3,25	5	004100142
10,00	133	87	3,55	5	004100148
10,50	133	87	4,30	5	004100172
11,00	142	94	5,05	5	004100184
11,50	142	94	5,30	5	004100196
12,00	151	101	5,85	5	004100210
12,50	151	101	6,35	5	004100222
13,00	151	101	6,75	5	004100234
14,00	160	108	8,95	5	004100242
15,00	169	114	10,50	5	004100250
16,00	178	120	13,00	5	004100258
17,00	184	125	14,30	3	004100262
18,00	191	130	17,00	3	004100266
19,00	198	135	19,30	3	004100270
20,00	205	140	22,80	3	004100274



	€	🔧	📦
410/SP19 Ø 1÷10 x 0,5 mm	37,50	1	004100419
410/SPV1	20,50	1	004100420
410/SP25 Ø 1÷13 x 0,5 mm	78,50	1	004100425
410/SPV2	29,00	1	004100426



410/SEL19 € 29,50 1 004100418
Ø 1÷10 x 0,5 mm

410MIX/SEL19

serie di 13 punte 410
e 6 punte con inserto in metallo duro



410MIX/SEL19 € 29,50 1 004100417



Ø 1 - 1,5 - 2 - 2,5 - 3 - 3,5 - 4
4,5 - 5 - 5,5 - 6 - 8 - 10 mm

Ø 4 - 5 - 6 - 8 - 9 - 10 mm

410A

punte elicoidali cilindriche
serie corta, in acciaio HSS rullate
con codolo ridotto

R ≤ 650 N/mm²
HV ≈ 750÷820



DIN 338 ISO 235

Ø mm	L mm	L1 mm	€	🔧	📦
13,50	160	108	10,60	5	004100281
14,00	160	108	10,60	5	004100283
14,50	169	114	12,10	5	004100285
15,00	169	114	12,10	5	004100287
15,50	178	120	15,00	5	004100289
16,00	178	120	15,00	5	004100291
16,50	184	125	15,90	3	004100292
17,00	184	125	15,90	3	004100293
17,50	191	130	19,00	3	004100294
18,00	191	130	19,00	3	004100295
18,50	198	135	20,90	3	004100296
19,00	198	135	20,90	3	004100297
19,50	205	140	24,50	3	004100298
20,00	205	140	24,50	3	004100299



410AS

punte elicoidali cilindriche
serie corta, in acciaio HSS
rullate,
in pollici

R ≤ 650 N/mm²
HV ≈ 750÷820



ANSI B94

Ø "	L mm	L1 mm	€	🔧	📦
1/16	48	22	0,50	10	004100371
5/64	51	25	0,56	10	004100372
3/32	57	32	0,63	10	004100373
7/64	67	38	0,70	10	004100374
1/8	70	41	0,77	10	004100375
9/64	73	44	0,83	10	004100376
5/32	79	51	0,90	10	004100377
11/64	83	54	1,00	10	004100378
3/16	89	59	1,16	10	004100379
13/64	92	62	1,20	10	004100380
7/32	95	64	1,30	10	004100381
15/64	98	67	1,52	10	004100382
1/4	102	70	1,72	10	004100383
17/64	105	73	2,02	10	004100384
9/32	108	75	2,22	10	004100385
19/64	111	78	2,47	10	004100386
5/16	114	81	3,15	10	004100387
21/64	117	84	3,25	10	004100388
11/32	121	87	3,75	5	004100389
23/64	124	89	3,85	5	004100390
3/8	127	92	4,00	5	004100391



410AS/SP21 € 56,50 1 004100429
Ø 1/16-5/64-3/32-7/64
1/8-9/64-5/32-11/64-3/16
13/64-7/32-15/64-1/4
17/64-9/32-19/64-5/16
21/64-11/32-23/64-3/8
410AS/SPV1 21,00 1 004100430



410AS/SEL21 € 45,50 1 004100433
Ø 1/16-5/64-3/32-7/64
1/8-9/64-5/32-11/64-3/16
13/64-7/32-15/64-1/4
17/64-9/32-19/64-5/16
21/64-11/32-23/64-3/8

412

punte elicoidali cilindriche
serie corta, in acciaio HSS
rettificate lucide

R ≤ 800 N/mm²
HV ~ 750+820



DIN 338 ISO 235

Ø mm	L mm	L1 mm	€	🔧	📦
0,50	22	6	2,25	10	004120030
1,00	34	12	1,45	10	004120040
1,25	38	16	1,55	10	004120043
1,50	40	18	1,30	10	004120046
1,75	46	22	1,30	10	004120049
2,00	49	24	1,10	10	004120052
2,25	53	27	1,40	10	004120055
2,50	57	30	1,20	10	004120058
2,75	61	33	1,40	10	004120061
3,00	61	33	1,25	10	004120064
3,25	65	36	1,65	10	004120067
3,50	70	39	1,50	10	004120070
3,75	70	39	1,80	10	004120073
4,00	75	43	1,65	10	004120076
4,25	75	43	2,10	10	004120079
4,50	80	47	1,90	10	004120082
4,75	80	47	2,25	10	004120085
5,00	86	52	2,10	10	004120088
5,25	86	52	3,00	10	004120091
5,50	93	57	2,75	10	004120094
5,75	93	57	3,30	10	004120097
6,00	93	57	2,90	10	004120100
6,25	101	63	4,15	10	004120103
6,50	101	63	3,65	10	004120106
6,75	109	69	4,65	10	004120109
7,00	109	69	4,30	10	004120112
7,25	109	69	5,25	5	004120115
7,50	109	69	4,50	5	004120118
7,75	117	75	5,95	5	004120121
8,00	117	75	5,45	5	004120124
8,25	117	75	6,60	5	004120127
8,50	117	75	6,70	5	004120130
8,75	125	81	7,40	5	004120133
9,00	125	81	7,00	5	004120136
9,25	125	81	8,10	5	004120139
9,50	125	81	7,30	5	004120142
9,75	133	87	9,00	5	004120145
10,00	133	87	8,10	5	004120148
10,25	133	87	12,20	5	004120149
10,50	133	87	10,80	5	004120150
10,75	142	94	14,70	5	004120151
11,00	142	94	12,90	5	004120152
11,25	142	94	15,70	5	004120153
11,50	142	94	13,60	5	004120154
11,75	142	94	17,00	5	004120155
12,00	151	101	14,90	5	004120156
12,25	151	101	18,50	5	004120157
12,50	151	101	16,00	5	004120158
12,75	151	101	21,00	5	004120159
13,00	151	101	16,90	5	004120160



Model	€	🔧	📦
412/SP19 Ø 1÷10 x 0,5 mm	74,50	1	004120419
412/SPV1	20,50	1	004120420
412/SP25 Ø 1÷13 x 0,5 mm	154,00	1	004120425
412/SPV2	29,00	1	004120426
412/SP49	368,00	1	004120449
412/SPV4 Ø 1÷13 x 0,25 mm	88,00	1	004120451

Beta

Quality Tools

412/C150



412/C150 € 451,00 1 004120450

412	Ø 3 mm	n.
	Ø 1 - 1,5 - 2 - 2,5 - 3 - 3,5 - 4 - 4,5 - 5 mm	10
	Ø 5,5 - 6 - 6,5 - 7 - 7,5 - 8 - 8,5 - 9 - 9,5 - 10 mm	5

📏 365x230x47 mm - 📦 3,3 kg



412/SP91 € 478,00 1 004120452

Ø 1÷10 x 0,10 mm

412A

punte elicoidali cilindriche
serie corta, in acciaio HSS
rettificate brunite
con codolo ridotto

R ≤ 800 N/mm²
HV ~ 750+820



DIN 338 ISO 235

Ø mm	L mm	L1 mm	€	🔧	📦
13,50	160	108	27,50	3	004120202
14,00	160	108	28,50	3	004120204
14,50	169	114	30,50	3	004120206
15,00	169	114	32,00	3	004120208
15,50	178	120	36,50	3	004120210
16,00	178	120	38,00	3	004120212
16,50	184	125	39,00	1	004120213
17,00	184	125	41,50	1	004120214
17,50	191	130	45,00	1	004120215
18,00	191	130	47,00	1	004120216
18,50	198	135	50,50	1	004120217
19,00	198	135	52,50	1	004120218
19,50	205	140	59,00	1	004120219
20,00	205	140	60,00	1	004120220

412C

punte elicoidali cilindriche
serie extra corta, in acciaio HSS
rettificate brunite

R ≤ 800 N/mm²
HV ~ 750+820



DIN 1897 ISO 235

Ø mm	L mm	L1 mm	€	🔧	📦
3,0	46	16	1,25	10	004120288
3,25	49	18	1,40	10	004120289
3,5	52	20	1,40	10	004120290
4,0	55	22	1,55	10	004120292
4,5	58	24	1,75	10	004120294
5,0	62	26	1,80	10	004120296
5,5	66	28	2,40	10	004120298
6,0	66	28	2,70	10	004120300
6,5	70	31	3,20	10	004120301
7,0	74	34	3,75	10	004120302
7,5	74	34	4,00	5	004120303
8,0	79	37	4,90	5	004120304

412L

punte elicoidali cilindriche
serie lunga, in acciaio HSS
rettificate brunite

R ≤ 800 N/mm²
HV ~ 750+820



DIN 340

Ø mm	L mm	L1 mm	€	🔧	📦
2,00	85	56	3,00	10	004120232
2,50	95	62	3,20	10	004120234
3,00	100	66	3,30	10	004120236
3,50	112	73	3,80	10	004120238
4,00	119	78	4,15	10	004120240
4,50	126	82	5,00	10	004120242
5,00	132	87	5,25	10	004120244
5,50	139	91	6,60	10	004120246
6,00	139	91	7,10	10	004120248
6,50	148	97	8,50	5	004120250
7,00	156	102	9,80	5	004120252
8,00	165	109	13,10	5	004120256
9,00	175	115	15,50	5	004120260
10,00	184	121	17,00	5	004120264



412XL

punte elicoidali cilindriche
serie extra lunga, in acciaio HSS

rettificate
R ≤ 800 N/mm²
HV ~ 750÷820



DIN 1869/1

Ø mm	L mm	L1 mm	€	🔧	📦
3,0	150	100	11,50	1	004120520
3,5	165	115	12,50	1	004120522
4,0	175	120	12,50	1	004120524
4,5	185	125	13,00	1	004120526
5,0	195	135	13,00	1	004120528
5,5	205	140	16,00	1	004120530
6,0	205	140	16,00	1	004120532
6,5	215	150	19,00	1	004120534
7,0	225	155	22,00	1	004120536
7,5	225	155	25,00	1	004120538
8,0	240	165	27,00	1	004120540
8,5	240	165	28,50	1	004120542
9,0	250	175	36,00	1	004120544
9,5	250	175	39,00	1	004120546
10,0	265	185	39,00	1	004120548
10,5	265	185	39,00	1	004120550
11,0	280	195	39,00	1	004120552
12,0	295	205	49,00	1	004120556
13,0	295	205	51,50	1	004120560

414

punte elicoidali cilindriche
serie corta, in acciaio HSS-TiN

rettificate
R ≤ 900 N/mm²
HV 0,05 ~ 2500



DIN 338 ISO 235

Ø mm	L mm	L1 mm	€	🔧	📦
1,00	34	12	1,97	10	004140040
1,25	38	16	2,25	10	004140042
1,50	40	18	1,75	10	004140046
1,75	46	22	2,25	10	004140048
2,00	49	24	1,85	10	004140052
2,25	53	27	2,30	10	004140054
2,50	57	30	1,95	10	004140058
2,75	61	33	2,65	10	004140060
3,00	61	33	2,20	10	004140064
3,25	65	36	2,85	10	004140066
3,50	70	39	2,65	10	004140070
3,75	70	39	2,95	10	004140072
4,00	75	43	2,65	10	004140076
4,25	75	43	3,25	10	004140078
4,50	80	47	2,95	10	004140082
4,75	80	47	3,70	10	004140084
5,00	86	52	3,40	10	004140088
5,25	86	52	4,75	10	004140090
5,50	93	57	4,10	10	004140094
5,75	93	57	5,00	10	004140096
6,00	93	57	4,60	10	004140100
6,25	101	63	5,85	10	004140102
6,50	101	63	5,10	10	004140106
6,75	109	69	7,00	10	004140108
7,00	109	69	5,65	10	004140112
7,25	109	69	7,70	5	004140114
7,50	109	69	6,90	5	004140118
7,75	117	75	9,00	5	004140120
8,00	117	75	8,05	5	004140124
8,25	117	75	9,40	5	004140125
8,50	117	75	8,40	5	004140130
8,75	125	81	11,70	5	004140132
9,00	125	81	10,50	5	004140136
9,25	125	81	13,30	5	004140138
9,50	125	81	11,70	5	004140142
9,75	133	87	14,00	5	004140144

Ø mm	L mm	L1 mm	€	🔧	📦
10,00	133	87	12,30	5	004140148
10,50	133	87	14,50	5	004140150
11,00	142	94	15,70	5	004140152
11,50	142	94	17,00	5	004140154
12,00	151	101	18,20	5	004140156
12,50	151	101	20,90	5	004140158
13,00	151	101	21,90	5	004140160



Model	€	🔧	📦
414/SP19 Ø 1÷10 x 0,5 mm	109,00	1	004140419
414/SPV1	21,00	1	004140420
414/SP25 Ø 1÷13 x 0,5 mm	220,00	1	004140425
414/SPV2	29,00	1	004140426
414/SP49 Ø 1÷13 x 0,25 mm	483,00	1	004140429
414/SPV4	88,00	1	004140430

414/C116



Model	€	🔧	📦
414/C116	444,00	1	004140450

414	Ø 1 - 1,5 - 2 - 2,5 - 3 - 3,5 - 4 - 4,5 - 5 mm	n.
	Ø 5,5 - 6 - 6,5 - 7 - 7,5 - 8 mm	10
	Ø 8,5 - 9 - 9,5 - 10 mm	3
		2

📏 365x230x47 mm - 🏠 2,7 Kg

415

punte elicoidali cilindriche
serie corta, in acciaio HSS-CO 8%

rettificate
R ≤ 1400 N/mm²
HV ~ 850÷920

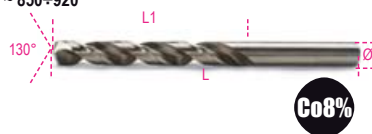

DIN 338 ISO 235

Ø mm	L mm	L1 mm	€	🔧	📦
0,50	22	6	5,55	10	004150029
1,00	34	12	2,75	10	004150040
1,25	38	16	3,05	10	004150043
1,50	40	18	2,75	10	004150046
1,75	46	22	2,90	10	004150049
2,00	49	24	2,65	10	004150052
2,25	53	27	3,25	10	004150055

Ø mm	L mm	L1 mm	€	🔧	📦
2,50	57	30	2,95	10	004150058
2,75	61	33	3,25	10	004150061
3,00	61	33	3,00	10	004150064
3,25	65	36	4,10	10	004150067
3,50	70	39	3,75	10	004150070
3,75	70	39	4,60	10	004150073
4,00	75	43	4,10	10	004150076
4,25	75	43	5,15	10	004150079
4,50	80	47	4,65	10	004150082
4,75	80	47	5,40	10	004150085
5,00	86	52	5,00	10	004150088
5,25	86	52	7,30	10	004150091
5,50	93	57	6,60	10	004150094
5,75	93	57	7,60	10	004150097
6,00	93	57	7,00	10	004150100
6,25	101	63	9,80	10	004150103
6,50	101	63	8,70	10	004150106
6,75	109	69	11,40	10	004150109
7,00	109	69	10,20	10	004150112
7,25	109	69	12,20	5	004150115
7,50	109	69	11,10	5	004150118
7,75	117	75	14,40	5	004150121
8,00	117	75	13,00	5	004150124
8,25	117	75	15,70	5	004150127
8,50	117	75	14,70	5	004150130
8,75	125	81	19,40	5	004150133
9,00	125	81	17,20	5	004150136
9,25	125	81	20,10	5	004150139
9,50	125	81	18,60	5	004150142
9,75	133	87	22,20	5	004150145
10,00	133	87	20,30	5	004150148
10,25	133	87	26,00	5	004150149
10,50	133	87	22,50	5	004150150
10,75	142	94	29,50	5	004150151
11,00	142	94	26,00	5	004150152
11,25	142	94	32,50	5	004150153
11,50	142	94	29,00	5	004150154
11,75	142	94	33,50	5	004150155
12,00	151	101	31,50	5	004150156
12,25	151	101	39,50	5	004150157
12,50	151	101	33,50	5	004150158
12,75	151	101	44,00	5	004150159
13,00	151	101	35,50	5	004150160
14,00	160	108	62,50	3	004150164
15,00	169	114	74,50	3	004150168
16,00	178	120	91,00	3	004150172
17,00	186	125	103,00	1	004150174
18,00	194	130	115,00	1	004150176
19,00	202	135	132,00	1	004150178
20,00	210	140	148,50	1	004150180



Model	€	🔧	📦
415/SP19 Ø 1÷10 x 0,5 mm	153,00	1	004150419
415/SPV1	20,50	1	004150420
415/SP25 Ø 1÷13 x 0,5 mm	316,00	1	004150425
415/SPV2	29,00	1	004150426
415/SP49 Ø 1÷13 x 0,25 mm	785,00	1	004150431
415/SPV4	88,00	1	004150432



415/C116



415/C116	€ 668,00	1	004150450
415		n.	
Ø 1 - 1,5 - 2 - 2,5 - 3 - 3,5 - 4 - 4,5 - 5 mm		10	
Ø 5,5 - 6 - 6,5 - 7 - 7,5 - 8 mm		3	
Ø 8,5 - 9 - 9,5 - 10 mm		2	
365x230x47 mm - 2,7 kg			



415/SP91	€ 915,00	1	004150460
Ø 1=10 x 0,10 mm			

415CO

punte elicoidali cilindriche
serie corta, in acciaio HSS-CO 5%
rettificate
R ≤ 1200 N/mm²
HV ~ 800+860



DIN 338 ISO 235

Ø mm	L mm	L1 mm	€		
1,0	34	12	1,40	10	004150310
1,5	40	18	1,40	10	004150312
2,0	49	24	1,40	10	004150314
2,5	57	30	1,45	10	004150316
3,0	61	33	1,45	10	004150320
3,5	70	39	1,80	10	004150322
4,0	75	43	2,10	10	004150324
4,5	80	47	2,40	10	004150326
5,0	86	52	2,50	10	004150328
5,5	93	57	3,20	10	004150330
6,0	93	57	3,50	10	004150332
6,5	101	63	4,20	10	004150334
7,0	109	69	5,20	10	004150336
7,5	109	69	5,70	5	004150338
8,0	117	75	6,70	5	004150340
8,5	117	75	7,00	5	004150342
9,0	125	81	8,60	5	004150344
9,5	125	81	9,00	5	004150346
10,0	133	87	10,50	5	004150348
10,5	133	87	12,50	5	004150350
11,0	142	94	14,00	5	004150352
11,5	142	94	15,30	5	004150354
12,0	151	101	16,80	5	004150356
12,5	151	101	18,30	5	004150358
13,0	151	101	19,90	5	004150360

415CO-A

punte elicoidali cilindriche
serie corta, in acciaio HSS-CO 5%
rettificate
R ≤ 1200 N/mm²
HV ~ 800+860



DIN 338

Ø mm	L mm	L1 mm	€		
14,0	160	108	39,00	3	004150364
15,0	169	114	45,50	3	004150366
16,0	178	120	54,50	3	004150368
17,0	184	125	55,50	1	004150370
18,0	191	130	71,50	1	004150372
19,0	198	135	82,00	1	004150374
20,0	205	140	95,00	1	004150376



DIN 338

415CO/SP19	€ 80,00	1	004150421
Ø 1=10 x 0,5 mm			
415/SPV1	€ 20,50	1	004150420

415C

punte elicoidali cilindriche
serie extra corta, in acciaio HSS-CO 5%
rettificate
R ≤ 1200 N/mm²
HV ~ 800+860



DIN 1897 ISO 235

Ø mm	L mm	L1 mm	€		
3,0	46	16	1,95	10	004150288
3,25	49	18	2,50	10	004150289
3,5	52	20	2,50	10	004150290
4,0	55	22	2,75	10	004150292
4,5	58	24	3,15	10	004150294
5,0	62	26	3,35	10	004150296
5,5	66	28	4,50	10	004150298
6,0	66	28	4,70	10	004150300
6,5	70	31	4,90	10	004150301
7,0	74	34	5,90	10	004150302
7,5	74	34	6,80	5	004150303
8,0	79	37	8,40	5	004150304



415L

punte elicoidali cilindriche
serie lunga, in acciaio HSS-CO 5%
rettificate
R ≤ 1200 N/mm²
HV ~ 800+860



DIN 340

Ø mm	L mm	L1 mm	€		
3,0	100	66	3,80	10	004150236
3,5	112	73	4,20	10	004150238
4,0	119	78	5,20	10	004150240
4,5	126	82	6,30	10	004150242
5,0	132	87	6,30	10	004150244
5,5	139	91	8,60	10	004150246
6,0	139	91	9,00	10	004150248
6,5	148	97	10,70	5	004150250
7,0	156	102	12,50	5	004150252
8,0	165	109	16,00	5	004150256
9,0	175	115	20,00	5	004150260
10,0	184	121	25,50	5	004150264

416

punta cilindrica con affilatura speciale
a doppia coppia di taglienti

R ≤ 900 N/mm²
HV ~ 820+850



DIN 338

Ø mm	L mm	L1 mm	€		
1,00	34	12	2,15	10	004160010
1,50	40	18	2,15	10	004160015
2,00	49	24	2,15	10	004160020
2,50	57	30	2,25	10	004160025
3,00	61	33	2,40	10	004160030
3,50	70	39	2,70	10	004160035
4,00	75	43	3,00	10	004160040
4,50	80	47	3,30	10	004160045
5,00	86	52	3,75	10	004160050
5,50	93	57	4,80	10	004160055
6,00	93	57	5,20	10	004160060
6,50	101	63	6,10	10	004160065
7,00	109	69	7,10	10	004160070
7,50	109	69	7,60	5	004160075
8,00	117	75	9,10	5	004160080
8,50	117	75	9,80	5	004160085
9,00	125	81	11,60	5	004160090
9,50	125	81	12,30	5	004160095
10,00	133	87	14,20	5	004160100

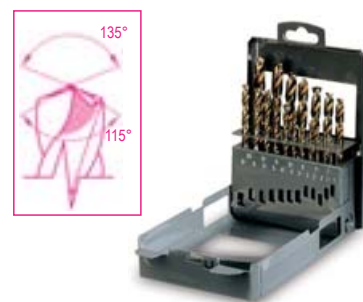

416/SP19	€ 108,00	1	004160419
Ø 1=10 x 0,5 mm			

417

punte elicoidali cilindriche per muratura
serie corta, in acciaio fresato
con placchetta in metallo duro



DIN 8039

Ø mm	L mm	€	🔧	📦
3	70	2,90	10	004170003
4	75	2,90	10	004170004
5	85	3,05	10	004170005
5L	150	6,80	5	004170105
6	100	3,15	10	004170007
6L	150	6,80	5	004170106
7	120	3,50	10	004170009
8	120	3,90	10	004170010
8L	200	7,40	5	004170113
9	120	4,45	10	004170011
10	120	5,15	10	004170012
10L	200	8,90	5	004170120
12	150	6,70	10	004170014
12L	200	9,50	5	004170125
14	150	9,30	5	004170016
16	150	11,60	5	004170018



417/SP8 € 44,00 1 004170100
Ø 3-4-5-6-8-9-10-12 mm

419

punte per muratura
corpo fresato con placchetta
in metallo duro
HVA~ 1650

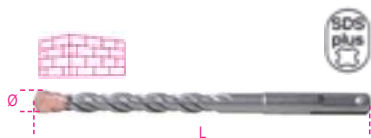

DIN 8039

Ø mm	L mm	€	🔧	📦
4	110	5,90	10	004190002
5	110	5,90	10	004190004
5	160	6,50	10	004190006
6	110	5,80	10	004190012
6	160	6,30	10	004190014
6	210	8,50	10	004190016
7	160	7,00	10	004190028
8	110	6,20	10	004190030
8	160	6,70	10	004190032
8	210	8,10	10	004190034
8	260	11,00	10	004190036
8	310	13,50	10	004190038
8	460	24,80	10	004190042
9	160	8,30	5	004190044
10	160	8,50	5	004190050
10	210	9,70	5	004190052
10	260	12,10	5	004190054
10	310	17,20	5	004190056

Ø mm	L mm	€	🔧	📦
10	460	26,50	5	004190060
12	160	9,40	5	004190064
12	210	12,70	5	004190066
12	260	13,70	5	004190068
12	460	28,00	5	004190074
14	160	13,00	3	004190086
14	260	15,70	3	004190090
14	310	22,70	3	004190092
14	460	29,50	3	004190096
16	210	19,20	3	004190112
16	250	20,20	3	004190114
16	300	24,50	3	004190116
16	450	32,50	3	004190120
18	250	26,00	1	004190124
20	310	26,00	1	004190128

419T

punte per muratura
corpo fresato con
4 eliche e 4 taglienti
HVA~ 1650

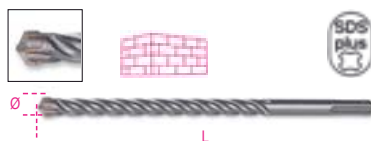

Ø mm	L mm	€	🔧	📦
5	110	3,95	5	004190604
5	160	4,55	5	004190606
6	110	4,20	5	004190612
6	160	4,90	5	004190614
6	210	6,70	5	004190616
7	160	5,00	5	004190628
8	110	4,60	5	004190630
8	160	5,20	5	004190632
8	210	6,90	5	004190634
8	260	7,90	5	004190636
8	310	9,50	5	004190638
9	160	5,50	3	004190644
10	160	5,55	3	004190650
10	210	7,40	3	004190652
10	260	8,00	3	004190654
10	310	11,50	3	004190656
10	460	15,50	3	004190660
12	160	6,15	3	004190664
12	210	8,10	3	004190666
12	260	8,60	3	004190668
12	460	16,00	3	004190674
14	160	8,40	2	004190686
14	260	9,70	2	004190690
14	310	13,90	2	004190692
14	460	15,50	2	004190696
16	210	11,20	2	004190712
16	260	14,70	2	004190714
16	310	15,90	2	004190716
16	460	16,50	2	004190720
18	260	18,00	1	004190724
20	310	22,00	1	004190728

420A

punte a gradino ad eliche indipendenti
per fori sedi viti 90°,
in acciaio HSS,
per fori passanti



DIN 8374

M	Ø mm	D mm	L1 mm	€	🔧	📦
3	3,4	6	9,00	42,00	1	004200003
4	4,5	8	11,00	48,50	1	004200004
5	5,5	10	13,00	61,00	1	004200005
6	6,6	11	15,00	70,50	1	004200006
8	9	15	19,00	119,00	1	004200008
10	11	18	23,00	184,00	1	004200010

420B

punte a gradino ad eliche indipendenti
per fori sedi viti 180°,
in acciaio HSS,
per fori passanti



DIN 8376

M	Ø mm	D mm	L1 mm	€	🔧	📦
3	3,2	6	9,00	37,00	1	004200053
4	4,3	8	11,00	41,50	1	004200054
5	5,3	10	13,00	51,00	1	004200055
6	6,4	11,5	15,00	60,00	1	004200056
8	8,4	15	19,00	75,00	1	004200058
10	10,5	19	23,00	112,00	1	004200060

421

svasatori con perno guida
grado fine
in acciaio HSS

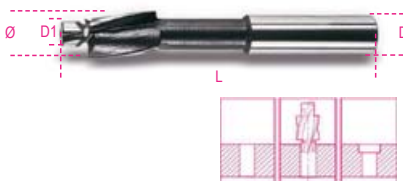

DIN 373

M	L mm	Ø mm	D1 mm	D mm	€	🔧	📦
3	71	6	3,2	5	21,60	1	004210003
4	71	8	4,3	5	21,60	1	004210004
5	80	10	5,3	8	21,60	1	004210005
6	80	11	6,4	8	22,00	1	004210006
8	100	15	8,4	12,5	35,50	1	004210008
10	100	18	10,5	12,5	42,50	1	004210010
12	100	20	13,0	12,5	46,50	1	004210012



421/SP6 € 175,00 1 004210019
M 3-4-5-6-8-10
421/SPV 13,00 1 004210020

422

punte a centrare rettificata
angolo di svasatura 60°
in acciaio HSS

• Per l'esecuzione rapida e sicura dei fori di centraggio



DIN 333/A

Ø mm	D mm	L mm	€		
1,60	4,0	35,5	6,80	1	004220116
2,50	6,3	45,0	7,80	1	004220125
3,15	8,0	50,0	8,80	1	004220131

423

punte speciali
per punti di saldatura
in acciaio HSS, rettificate



Ø mm	L mm	€		
6	66	13,50	5	004230006
7	74	16,50	5	004230007
8	79	18,00	5	004230008
10	89	21,00	5	004230010

423A

frese speciali per punti
di saldatura, in acciaio HSS
rettificate



DIN 1412/E

Ø mm	L mm	€		
6,5	40	19,50	1	004230015
8,0	40	21,30	1	004230020

424

frese coniche per forare
ed allargare
in acciaio HSS

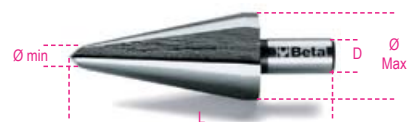

	L mm	Ø mm	D mm	€		
424/1	58	3÷14	6	24,50	2	004240001
424/2	63	6÷20	8	41,00	2	004240002
424/3	60	16÷30	10	71,50	2	004240003
424/4	80	3÷22	8	87,00	1	004240004
424/5	102	3÷31	10	117,00	1	004240005
424/6	86	26÷40	13	148,50	1	004240006
424/7	89	36÷50	13	222,00	1	004240007
424/8	90	40÷61	13	368,00	1	004240008



424/SP3	142,00	1	004240019
424/1+424/2+424/3			
Ø 3÷30 mm			
424/SPV	19,50	1	004240020

425

frese coniche a gradino
in acciaio HSS



	L mm	Ø mm	S mm	D mm	€		
425/1	70	4÷12	1	6	41,50	2	004250010
425/2	55	4÷12	2	6	44,50	2	004250012
425/3	85	4÷20	2	10	64,00	2	004250015
425/4	85	12÷20	1	10	98,00	1	004250016
425/5	97	20÷30	1	10	192,00	1	004250017
425/6	75	4÷30	2	10	134,00	1	004250020
425/7	97	30÷40	1	13	267,00	1	004250025
425/8	100	40÷50	1	13	372,00	1	004250029



425/SP3	244,00	1	004250030
425/1+425/3+425/6			
Ø 4÷30 mm			
425/SPV	19,50	1	004250035

426

frese a svasare ed incassare
a tre taglienti
in acciaio HSS



DIN 335-C

GR	Ø mm	L mm	Ø1 mm	€		
1	4,3	44	4	14,00	3	004260001
2	5,3	44	4	14,00	3	004260002
3	6,3	44	5	14,50	3	004260003
4	7,3	44	6	17,00	3	004260004
5	8,3	50	6	17,00	3	004260005
6	9,4	50	6	19,00	3	004260006
7	10,4	54	6	21,50	3	004260007
8	12,4	54	8	23,00	3	004260008
9	15,0	56	10	25,50	3	004260009
10	16,5	60	10	27,50	3	004260010

GR	Ø mm	L mm	Ø1 mm	€		
11	20,5	63	10	38,00	3	004260011
12	25,0	66	10	60,00	3	004260012
13	28,0	71	12	80,00	3	004260013
14	31,0	71	12	85,00	3	004260014



DIN 335-C

426/SP6	149,00	1	004260030
GR 3-5-7-8-10-11			
Ø 6,3÷20,5 mm			
426/SPV	19,50	1	004260035

426T

frese a svasare ed incassare
a tre taglienti
in acciaio HSS + TiN



DIN 335-C

GR	Ø mm	L mm	Ø1 mm	€		
1	4,3	44	4	18,00	3	004260061
2	5,3	44	4	18,00	3	004260062
3	6,3	44	5	18,50	3	004260063
4	7,3	44	6	21,00	3	004260064
5	8,3	50	6	21,00	3	004260065
6	9,4	50	6	22,50	3	004260066
7	10,4	54	6	25,50	3	004260067
8	12,4	54	8	27,00	3	004260068
9	15,0	56	10	30,50	3	004260069
10	16,5	60	10	34,00	3	004260070
11	20,5	63	10	44,50	3	004260071
12	25,0	66	10	67,00	3	004260072
13	28,0	71	12	84,00	3	004260073
14	31,0	71	12	89,00	3	004260074



DIN 335-C

426T/SP6	170,00	1	004260080
GR 3-5-7-8-10-11			
Ø 6,3÷20,5 mm			
426T/SPV	19,50	1	004260035

426SB

frese a sbavare e svasare
in acciaio HSS



	GR	Ø mm	D mm	L mm	€		
426/SB1	1	2÷5	6	45	18,80	1	004260101
426/SB2	2	5÷10	8	48	23,30	1	004260102
426/SB3	3	10÷15	10	65	41,50	1	004260103
426/SB4	4	15÷20	12	85	80,50	1	004260104
426/SB5	5	20÷25	15	102	135,50	1	004260105
426/SB6	6	25÷30	15	115	229,00	1	004260106



426SB/SP4	187,00	1	004260130
426/SB1-426/SB2			
426/SB3-426/SB4			
Ø 2÷20 mm			
426SB/SPV1	19,50	1	004260135

426MD-3/CP3

mini frese rotative in metallo duro

• Taglio incrociato tipo dolce con rompitruciolo



L mm	Ø mm	€	
38,1	3	10,30	1 004260332

426MD-3/CT3

mini frese rotative in metallo duro

• Taglio incrociato tipo dolce con rompitruciolo



L mm	Ø mm	€	
37,8	3	10,30	1 004260333

426MD-3/F3

mini frese rotative in metallo duro

• Taglio incrociato tipo dolce con rompitruciolo



L mm	Ø mm	€	
38,3	3	10,30	1 004260334

426MD-3/FA3

mini frese rotative in metallo duro

• Taglio incrociato tipo dolce con rompitruciolo



L mm	Ø mm	€	
38,2	3	10,30	1 004260339

426MD-3/OG3

mini frese rotative in metallo duro

• Taglio incrociato tipo dolce con rompitruciolo



L mm	Ø mm	€	
38,1	3	10,30	1 004260337

426MD-3/OV3

mini frese rotative in metallo duro

• Taglio incrociato tipo dolce con rompitruciolo



L mm	Ø mm	€	
38,2	3	10,30	1 004260331

426MD-3/S3

mini frese rotative in metallo duro

• Taglio incrociato tipo dolce con rompitruciolo



L mm	Ø mm	€	
38,0	3	10,30	1 004260338

426MD-3/T3

mini frese rotative in metallo duro

• Taglio incrociato tipo dolce con rompitruciolo



L mm	Ø mm	€	
38,3	3	10,30	1 004260336

426MD-3/TA3

mini frese rotative in metallo duro

• Taglio incrociato tipo dolce con rompitruciolo



L mm	Ø mm	€	
38,3	3	10,30	1 004260335



426MD-3/A9	92,50	1	004260349
426MD-3/OV3 - 426MD-3/CP3			
426MD-3/CT3 - 426MD-3/F3			
426MD-3/TA3 - 426MD-3/T3			
426MD-3/OG3 - 426MD-3/S3			
426MD-3/FA3			

426MD/CP

lime rotative in metallo duro

taglio incrociato HM6



L mm	Ø mm	€	
50	6	29,00	1 004260532
63	8	32,00	1 004260512
63	9,5	35,50	1 004260542
69	12	50,00	1 004260522
69	16	72,00	1 004260552

426MD/CT

lime rotative in metallo duro

taglio incrociato HM6



L mm	Ø mm	€	
50	6	29,00	1 004260533
63	8	32,00	1 004260513
63	9,5	35,50	1 004260543
69	12	50,00	1 004260523
69	16	70,00	1 004260553

426MD/F

lime rotative in metallo duro

taglio incrociato HM6



L mm	Ø mm	€	
50	6	29,00	1 004260534
63	8	32,00	1 004260514
63	9,5	35,50	1 004260544
69	12	50,00	1 004260524
69	16	57,00	1 004260554

426MD/FA

lime rotative in metallo duro

taglio incrociato HM6

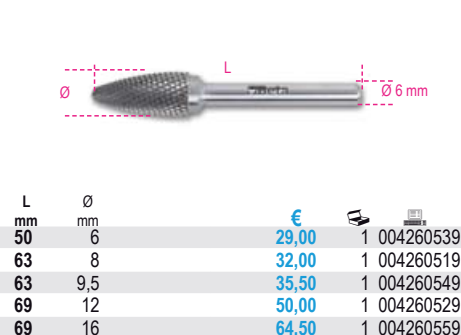

L mm	Ø mm	€	
50	6	29,00	1 004260539
63	8	32,00	1 004260519
63	9,5	35,50	1 004260549
69	12	50,00	1 004260529
69	16	64,50	1 004260559



426MD/OG

lime rotative in metallo duro

taglio incrociato HM6



L mm	Ø mm	€		
50	6	29,00	1	004260537
63	8	32,00	1	004260517
70	10	35,50	1	004260547
76	12	50,00	1	004260527
81	16	72,00	1	004260557



426MD/SP10	€		
426MD/CP-426MD/CT-426MD/F	370,00	1	004260510
426MD/T-426MD/S			
Ø 8-12 mm			

426MD/OV

lime rotative in metallo duro

taglio incrociato HM6



L mm	Ø mm	€		
50	6	29,00	1	004260531
61	9,5	35,50	1	004260541
67	12	50,00	1	004260521
69	16	64,50	1	004260551

426MD/S

lime rotative in metallo duro

taglio incrociato HM6



L mm	Ø mm	€		
50	6	29,00	1	004260538
51	8	32,00	1	004260518
53	9,5	35,50	1	004260548
56	12	50,00	1	004260528
59	16	57,00	1	004260558

426MD/T

lime rotative in metallo duro

taglio incrociato HM6



L mm	Ø mm	€		
50	6	29,00	1	004260536
63	8	32,00	1	004260516
63	9,5	35,50	1	004260546
69	12	50,00	1	004260526
70	16	57,00	1	004260556

426MD/TA

lime rotative in metallo duro

taglio incrociato HM6



L mm	Ø mm	€		
50	6	29,00	1	004260535
67	8	32,00	1	004260515
72	9,5	35,50	1	004260545
73	12	50,00	1	004260525
78	16	72,00	1	004260555

428FC

maschi a macchina per fori ciechi
passo grosso
in acciaio HSS



ISO 529

M	■ mm	L mm	L1 mm	€		
3x0,5	2,7	56	11	16,70	10	004280103
4x0,7	3,4	63	13	16,70	10	004280104
5x0,8	4,9	70	16	16,70	10	004280105
6x1	4,9	80	19	17,20	10	004280106
8x1,25	6,2	90	22	18,70	10	004280108
10x1,5	8,0	100	24	22,30	10	004280110
12x1,75	7,0	110	29	28,50	5	004280112
14x2	9,0	110	30	38,00	5	004280114
16x2	9,0	110	30	45,00	5	004280116
18x2,5	11,0	125	34	60,00	3	004280118
20x2,5	12,0	140	34	63,50	3	004280120
22x2,5	14,5	140	34	77,50	3	004280122
24x3	14,5	160	38	82,50	3	004280124

428/C14

assortimento di 14 maschi a macchina
428FP+428FC



428/C14	€		
428FP M3=12	300,00	1	004280201
428FC M3=12			
428/SPV	17,50	1	004280202

427

estrattori coni Morse



DIN 317

GR	L mm	A mm	€		
0	92	13	9,90	3	004270000
1-2	140	19	14,10	3	004270002
3	190	25	16,90	3	004270003
4	225	30	29,00	3	004270004
5-6	260	35	52,50	3	004270006

428FP

maschi a macchina per fori passanti
passo grosso
in acciaio HSS



ISO 529

M	■ mm	L mm	L1 mm	€		
3x0,5	2,7	56	11	13,80	10	004280003
4x0,7	3,4	63	13	13,80	10	004280004
5x0,8	4,9	70	16	13,80	10	004280005
6x1	4,9	80	19	14,50	10	004280006
8x1,25	6,2	90	22	17,50	10	004280008
10x1,5	8,0	100	24	20,50	10	004280010
12x1,75	7,0	110	29	27,00	5	004280012
14x2	9,0	110	30	33,00	5	004280014
16x2	9,0	110	30	39,50	5	004280016
18x2,5	11,0	125	34	51,00	3	004280018
20x2,5	12,0	140	34	58,00	3	004280020
22x2,5	14,5	140	34	69,00	3	004280022
24x3	14,5	160	38	75,00	3	004280024

429FP

maschi a macchina per fori passanti
passo grosso
in acciaio HSS-CO 5%



ISO 529

M	■ mm	L mm	L1 mm	€		
3x0,5	2,7	56	11	18,00	5	004290003
4x0,7	3,4	63	13	18,00	5	004290004
5x0,8	4,9	70	16	18,00	5	004290005
6x1	4,9	80	19	19,50	5	004290006
8x1,25	6,2	90	22	21,50	5	004290008
10x1,5	8,0	100	24	25,00	5	004290010
12x1,75	7,0	110	29	32,00	5	004290012
14x2	9,0	110	30	42,50	5	004290014

429FC

maschi a macchina per fori ciechi
passo grosso
in acciaio HSS-CO 5%

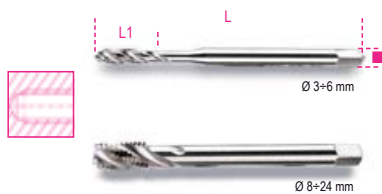

ISO 529

M	■ mm	L mm	L1 mm	€	📦	🏠
3x0,5	2,7	56	11	22,00	5	004290103
4x0,7	3,4	63	13	22,00	5	004290104
5x0,8	4,9	70	16	22,00	5	004290105
6x1	4,9	80	19	23,00	5	004290106
8x1,25	6,2	90	22	25,50	5	004290108
10x1,5	8,0	100	24	31,50	5	004290110
12x1,75	7,0	110	29	38,00	5	004290112
14x2	9,0	110	30	49,00	5	004290114

429/C14

assortimento di 14 maschi a macchina
429FP+429FC



429/C14	€	📦	🏠
429FP M3÷12	368,00	1	004290201
429FC M3÷12			
428/SPV	17,50	1	004280202

430

serie di 3 maschi a mano
sgrossatore, intermedio, finitore
passo grosso, in acciaio al cromo



ISO 529

M	■ mm	L mm	L1 mm	€	📦	🏠
2x0,4	2,5	36	11	12,00	5	004300002
3x0,5	2,5	40	12	8,50	5	004300003
4x0,7	3,0	45	14	8,50	5	004300004
5x0,8	4,0	48	16	8,80	5	004300005
6x1	5,0	50	18	8,90	5	004300006
7x1	4,5	50	18	11,40	5	004300007
8x1,25	5,0	56	22	11,50	3	004300008
9x1,25	5,5	63	22	15,50	3	004300009
10x1,5	6,0	70	25	14,70	3	004300010
11x1,5	7,0	70	25	19,00	3	004300011
12x1,75	7,0	75	30	19,00	3	004300012
14x2	8,0	80	32	23,80	3	004300014
16x2	10,0	80	32	28,50	3	004300016
18x2,5	11,0	95	40	38,00	1	004300018
20x2,5	12,0	95	40	46,00	1	004300020
22x2,5	14,5	100	40	55,00	1	004300022
24x3	14,5	110	50	65,00	1	004300024



430/SP21	€	📦	🏠
M 3-4-5-6-8-10-12	102,00	1	004300201
430/SPV	21,00	1	004300202

430ASW

serie di 3 maschi a mano
sgrossatore, intermedio, finitore
Whitworth, in acciaio al cromo



DIN 352

BSW	■ mm	L mm	L1 mm	€	📦	🏠
1/8x40	2,7	40	12	8,35	5	004300031
5/32x32	3,4	45	14	8,35	5	004300032
3/16x24	4,3	48	18	8,35	5	004300033
1/4x20	4,9	50	22	9,60	5	004300034
5/16x18	4,9	56	25	11,80	3	004300035
3/8x16	5,5	70	28	15,50	3	004300036
7/16x14	6,2	70	30	17,50	3	004300037
1/2x12	7,0	75	32	19,60	3	004300038
9/16x12	9,0	80	32	23,70	1	004300039
5/8x11	9,0	80	38	29,00	1	004300040
3/4x10	11,0	95	40	41,50	1	004300041
7/8x9	14,5	100	40	52,50	1	004300042
1"x8	16,0	110	50	67,50	1	004300043

430ASC

serie di 3 maschi a mano
sgrossatore, intermedio, finitore
UNC, in acciaio al cromo

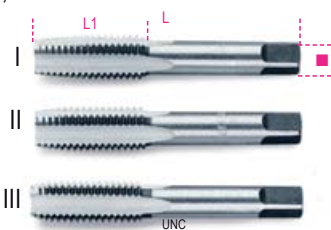

ANSI B.1

UNC	■ mm	L mm	L1 mm	€	📦	🏠
1/4x20	4,9	70	30	12,30	5	004300051
5/16x18	4,9	70	30	16,00	5	004300052
3/8x16	5,5	75	35	18,00	3	004300053
7/16x14	6,2	80	40	23,20	3	004300054
1/2x13	7,0	85	45	30,00	3	004300055
9/16x12	9,0	90	45	36,00	3	004300056
5/8x11	9,0	100	47	41,50	3	004300057
3/4x10	11,0	110	50	56,50	3	004300058
7/8x9	14,5	120	60	64,50	1	004300059
1"x8	16,0	130	60	73,00	1	004300060

431

serie di 3 maschi a mano
sgrossatore, intermedio, finitore
passo grosso, in acciaio HSS



DIN 352 UNI 4535

M	■ mm	L mm	L1 mm	€	📦	🏠
3x0,5	2,5	40	12	16,00	5	004310003
4x0,7	3,0	45	14	16,00	5	004310004
5x0,8	4,0	48	16	16,50	5	004310005
6x1	5,0	50	18	16,50	5	004310006
7x1	5,0	50	18	22,20	5	004310007
8x1,25	5,0	56	22	20,00	3	004310008
10x1,5	6,0	70	25	24,50	3	004310010
12x1,75	7,0	75	30	37,50	3	004310012
14x2	9,0	80	32	52,50	1	004310014
16x2	9,0	80	32	59,50	1	004310016
18x2,5	11,0	95	40	88,50	1	004310018
20x2,5	12,0	95	40	95,00	1	004310020
22x2,5	12,0	100	40	136,00	1	004310022
24x3	14,5	110	50	153,00	1	004310024



431/SP21	€	📦	🏠
M 3-4-5-6-8-10-12	185,00	1	004310201
431/SPV	21,00	1	004310202

433

serie di 2 maschi a mano
sgrossatore e finitore
passo fine, in acciaio al cromo



DIN 2181 UNI 4535

M	■ mm	L mm	L1 mm	€	📦	🏠
6x0,75	4,5	48	16	7,40	5	004330201
7x0,75	4,5	56	18	9,20	5	004330202
8x0,75	5,0	50	16	9,20	5	004330203
8x1	5,0	56	16	9,20	5	004330204
9x0,75	6,0	63	22	12,00	5	004330205
9x1	6,0	63	22	12,00	5	004330206
10x0,75	6,5	63	18	12,00	5	004330207
10x1	6,5	63	18	12,00	5	004330208
10x1,25	6,5	63	18	12,00	5	004330209
11x0,75	7,0	70	25	16,20	3	004330210
11x1	7,0	70	25	16,20	3	004330211
11x1,25	7,0	70	25	16,20	3	004330212
12x0,75	7,0	70	20	15,70	3	004330213
12x1	7,0	70	20	15,70	3	004330214
12x1,25	7,0	70	20	15,70	3	004330215
12x1,5	7,0	70	20	15,70	3	004330216
14x1	8,0	80	32	20,50	1	004330217
14x1,25	8,0	80	32	20,50	1	004330218
14x1,5	8,0	80	32	20,50	1	004330219
16x1	10,0	80	32	24,20	1	004330220
16x1,5	10,0	80	32	24,20	1	004330221

M	mm	L	L1	€		
18x1,5	11,0	95	40	29,00	1	004330222
18x2	11,0	80	25	37,50	1	004330223
20x1,5	14,5	80	22	42,50	1	004330224
22x1,5	14,5	80	22	50,50	1	004330225
24x1,5	14,5	80	22	59,50	1	004330226
24x2	14,5	80	22	59,00	1	004330227

433ASF

serie di 2 maschi a mano
UNF, passo fine
in acciaio al cromo

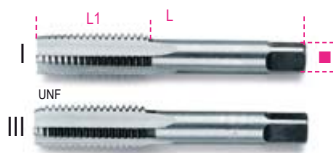

ANSI B1.1

UNF	mm	L	L1	€		
1/4x28	4,9	70	30	9,30	5	004330301
5/16x24	4,9	70	30	11,20	5	004330302
3/8x24	5,5	75	35	12,50	3	004330303
7/16x20	6,2	80	40	16,00	3	004330304
1/2x20	7,0	85	45	20,30	3	004330305
9/16x18	9,0	90	45	24,90	3	004330306
5/8x18	9,0	100	47	29,00	3	004330307
3/4x16	11,0	110	50	39,00	3	004330308
7/8x14	14,5	120	60	50,00	1	004330309
1"x12	16,0	130	60	68,50	1	004330310

433ASG

serie di 2 maschi a mano
filettatura GAS cilindrica
in acciaio al cromo

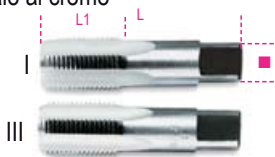

DIN 5157

GAS	mm	L	L1	€		
1/8x28	5,5	65	18	13,30	1	004330401
1/4x19	9,0	70	24	17,00	1	004330402
3/8x19	9,0	75	25	20,50	1	004330403
1/2x14	12,0	80	31	29,50	1	004330405
3/4x14	16,0	90	33	48,00	1	004330408
1"x11	20,0	100	39	77,50	1	004330410

434

serie di 2 maschi a mano
sgrossatore e finitore
passo fine, in acciaio HSS

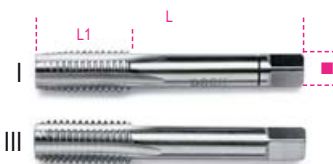

DIN 2181 UNI 4535

M	mm	L	L1	€		
6x0,75	4,5	48	16	21,00	5	004340001
8x0,75	5,0	56	16	24,50	5	004340003
8x1	5,0	56	16	24,50	5	004340004
10x0,75	6,5	63	18	31,50	5	004340007
10x1	6,5	63	18	31,50	5	004340008
10x1,25	6,5	63	18	31,50	5	004340009
12x1	7,0	70	20	33,50	3	004340014
12x1,25	7,0	70	20	33,50	3	004340015
12x1,5	7,0	70	20	33,50	3	004340016
13x1,5	9,0	70	20	70,00	1	004340017
14x1	9,0	70	20	41,50	1	004340018
14x1,25	9,0	70	20	41,50	1	004340019
14x1,5	9,0	70	20	35,50	1	004340020

M	mm	L	L1	€		
15x1,5	9,0	70	20	70,00	1	004340021
16x1	9,0	70	20	45,50	1	004340022
16x1,5	9,0	70	20	38,50	1	004340023
18x1,5	11,0	80	22	49,50	1	004340024
18x2	11,0	90	25	60,50	1	004340025
20x1,25	12,0	80	22	86,00	1	004340026
20x1,5	12,0	80	22	53,50	1	004340027
20x2	12,0	90	25	65,50	1	004340028
22x1,5	14,5	80	22	75,50	1	004340029
24x1	14,5	80	22	102,00	1	004340030
24x1,5	14,5	80	22	86,00	1	004340031
24x2	14,5	80	22	89,00	1	004340032

435

giramaschi regolabili
corpo in acciaio



DIN 1814

	mm	L	€		
435/0	2÷5 M1÷M8	170	14,30	3	004350007
435/1	2÷6 M1÷M10	200	17,30	2	004350009
435/1,5	2,5÷6 M1÷M12	200	18,30	2	004350011
435/2	3÷7 M4÷M12	260	25,50	2	004350013
435/3	4÷12 M5÷M20	345	43,50	1	004350020
435/4	5,5÷16 M9÷M27	430	67,00	1	004350027
435/5	7÷18 M13÷M32	770	152,00	1	004350032

435G

giramaschi regolabili
corpo in lega leggera



DIN 1814

	mm	L	€		
435G/0	2÷5 M1÷M8	130	10,20	5	004350108
435G/1	2÷6 M1÷M10	190	12,40	5	004350110
435G/1,5	2÷7 M2÷M12	175	13,00	5	004350112
435G/2	3,4÷7 M4÷M12	280	21,50	5	004350114
435G/3	4,9÷12 M5÷M20	380	34,50	2	004350121
435G/4	7÷16 M11÷M27	500	55,00	2	004350127
435G/5	7÷18 M13÷M32	700	87,00	1	004350132
435G/6	11÷24 M18÷M42	800	143,00	1	004350142

436

giramaschi a cricchetto
reversibile

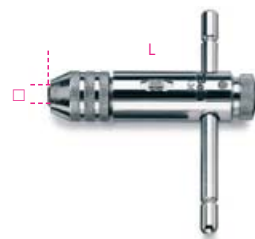

	mm	L	€		
436/1	2÷5 M3÷M8	85	23,80	5	004360002
436/2	4,6÷8 M5÷M12	110	30,50	5	004360004

436L

giramaschi a cricchetto
reversibile, tipo lungo



	mm	L	€		
436L/1	2÷5 M3÷M8	245	38,00	2	004360012
436L/2	4,6÷8 M5÷M12	295	44,50	2	004360014

436R

morsetti di ricambio per 436 e 436L

	€		
436R/1	4,50	1	004360022
436R/2	5,00	1	004360024

437P

ravvivafiletto,
per ripristino di filettature interne ed esterne,
destre e sinistre

P 0,80÷3,00 mm



L	mm	€		
230		39,00	1	004370003

437C

set ripristino filettature candela danneggiate,
M14x1,25 mm

• altezza elicoidi: 8,40 - 12,40 - 16,40 mm. (5 pz per misura)



437C	€		
	101,00	1	004370100

437C/...

elicoidi in acciaio inossidabile per 437C



H mm	€	Icona	Icona
8.4	25,50	1	004370108
12.4	25,50	1	004370112
16.4	25,50	1	004370116

I prezzi indicati sono relativi a 10 pezzi

437C/RM14

maschi filetti candele M14x1,25



437C/RM14	€ 84,00	Icona	Icona	1	004370124
-----------	---------	-------	-------	---	-----------

437K/8

assortimento per ripristino filetti semiassi

- permette di ripassare e ravvivare il filetto originale
- Incluse nel kit:
 - misure metriche: 20x1,25 - 20x1,5 - 22x1,00 - 22x1,5 - 24x1,5 - 24x2,00
 - misure in pollici: 3/4x20 - 13/16x20



32 mm

437K/8	€ 66,50	Icona	Icona	1	004370020
--------	---------	-------	-------	---	-----------

200x110x30 mm

437K/9

assortimento per ripristino filettature maschio e femmina, viti fissaggio ruote

permette di ripassare e ravvivare il filetto originale

- Inclusi nel kit:
 - maschi: M12x1,25 - M12x1,5 - M12x1,75 - M14x1,5
 - filiere: M12x1,25 - M12x1,5 - M14x1,5



12 - 24 mm

437K/9	€ 70,00	Icona	Icona	1	004370029
--------	---------	-------	-------	---	-----------

161x123x50 mm

437K/10

assortimento per il ripristino delle filettature danneggiate dei sensori ossigeno M18x1,5

- inclusi nel kit:
 - 1 alesatore pilota M18
 - 1 maschio M18x1,5
 - 1 maschio M20x1,5
 - 5 boccole filettate M18x1,5
 - 1 utensile di manovra per boccole



13 - 27 mm

437K/10	€ 105,00	Icona	Icona	1	004370030
---------	----------	-------	-------	---	-----------

190x105x40 mm

437K/12

assortimento per ripristino filetti semiassi

permette di ripassare e ravvivare il filetto originale

- Inclusi nel kit:
 - misure metriche: M16x1,0 - M16x1,5 - M20x1,0 - M20x1,5 - M22x1,5 - M24x1,5 - M24x2,0 - M27x2,0
 - misure in pollici: 3/4x16 - 3/4x20 - 13/16x20 - 27/32x20



32 - 35 mm

437K/12	€ 84,00	Icona	Icona	1	004370032
---------	---------	-------	-------	---	-----------

220x118x52 mm

437K/16

assortimento per il ripristino delle filettature danneggiate dei supporti pinze freno M9x1,25



437K/16	€ 93,50	Icona	Icona	1	004370016
---------	---------	-------	-------	---	-----------

210x150x50 mm

437K/33

assortimento per il ripristino delle filettature candelette danneggiate

- Boccole: M8x1,0 - M10x1,0 - M10x1,25 - M12x1,25
- Maschi: M8x1,0 - M10x1,0 - M10x1,25 - M12x1,0 - M12x1,25 - M14x1,25



437K/33	€ 233,00	Icona	Icona	1	004370133
---------	----------	-------	-------	---	-----------

210x150x50 mm

437U/09

assortimento per il ripristino delle filettature danneggiate



25 x M5, M6, M8, M10
10 x M12

437U/09	€ 282,00	Icona	Icona	1	004370550
---------	----------	-------	-------	---	-----------

M5X0,8
M6X1,0
M8X1,25
M10X1,5
M12X1,75

370x230x55 mm - 2 Kg

437U/E-M...

elicoidi in acciaio inossidabile



H mm	€	Icona	Icona	
M5	7,5	14,90	1	004370555
M6	9	14,90	1	004370556
M8	12	20,70	1	004370558
M10	15	27,00	1	004370560
M12	18	17,20	1	004370562

I prezzi indicati sono relativi a 25 pezzi (10 per la misura M12)

437U/PM

punte e maschi per 437U/09



M5	€ 28,50	Icona	Icona	1	004370565
M6	30,00	Icona	Icona	1	004370566
M8	40,00	Icona	Icona	1	004370568
M10	52,50	Icona	Icona	1	004370570
M12	65,00	Icona	Icona	1	004370572

438A

serie di punte per forare, filettare e svasare; in acciaio HSS

- M3 - M4 - M5 - M6 - M8 - M10
- con portainseriti magnetico

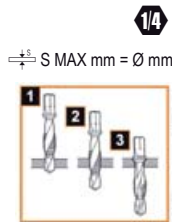

438A € 95,50 1 004380010

438...

punte per forare, filettare e svasare

in acciaio HSS, attacco 1/4"

1/4"



M	S max mm	€		
M3	3	18,30	2	004380103
M4	4	18,30	2	004380104
M5	5	18,30	2	004380105
M6	6	18,30	2	004380106
M8	8	20,60	2	004380108
M10	10	20,60	2	004380110

440

filire tonde passo grosso
in acciaio al cromo

R ≤ 600 N/mm²
HRC ~ 60÷61



UNI 4535
DIN 223

M	Ø x S mm	€		
2x0,4	25,4 x 9	14,40	5	004400002
3x0,5	25,4 x 9	10,70	5	004400003
4x0,7	25,4 x 9	10,70	5	004400004
5x0,8	25,4 x 9	9,10	5	004400005
6x1	25,4 x 9	9,10	5	004400006
7x1	25,4 x 9	9,10	5	004400007
8x1,25	25,4 x 9	9,10	5	004400008
9x1,25	25,4 x 9	9,10	5	004400009
10x1,5	25,4 x 9	9,10	5	004400010
12x1,75	25,4 x 9	9,10	5	004400012

440A

filire tonde passo grosso
in acciaio al cromo

R ≤ 600 N/mm²
HRC II 60÷61



UNI 4535
DIN 223

M	Ø x S mm	€		
10x1,5	38,1 x 14	13,00	3	004400110
11x1,5	38,1 x 14	13,00	3	004400111
12x1,75	38,1 x 14	13,00	3	004400112
14x2	38,1 x 14	13,00	3	004400114
16x2	38,1 x 14	13,00	3	004400116
18x2,5	38,1 x 14	15,00	3	004400118
20x2,5	38,1 x 14	16,70	3	004400120

440B

filire tonde passo grosso
in acciaio al cromo

R ≤ 600 N/mm²
HRC ~ 60÷61



UNI 4535
DIN 223

M	Ø x S mm	€		
18x2,5	50,8 x 16	23,00	3	004400122
20x2,5	50,8 x 16	24,20	3	004400124
22x2,5	50,8 x 16	26,00	3	004400126
24x3	50,8 x 16	26,50	3	004400128

440ASW

filire tonde Whitworth
in acciaio al cromo

R ≤ 600 N/mm²



UNI EN 22568
DIN 223

BSW	Ø x S mm	€		
1/8x40	25,4 x 9	12,20	5	004400201
5/32x32	25,4 x 9	12,20	5	004400202
3/16x24	25,4 x 9	11,00	5	004400203
1/4x20	25,4 x 9	11,00	5	004400204
5/16x18	25,4 x 9	11,00	5	004400205
3/8x16	38,1 x 14	15,70	3	004400206
7/16x14	38,1 x 14	15,70	3	004400207
1/2x12	38,1 x 14	16,20	3	004400208
9/16x12	38,1 x 14	16,20	3	004400209
5/8x11	50,8 x 16	28,50	3	004400210
3/4x10	50,8 x 16	28,50	3	004400211
7/8x9	50,8 x 16	32,50	3	004400212
1"x8	50,8 x 16	32,50	3	004400213

440ASC

filire tonde, UNC
passo grosso, in acciaio al cromo

R ≤ 600 N/mm²



UNI EN 22568
DIN 223

UNC	Ø x S mm	€		
1/4x20	25,4 x 9	10,90	5	004400221
5/16x18	25,4 x 9	10,90	5	004400222
3/8x16	38,1 x 14	15,00	3	004400223
7/16x14	38,1 x 14	15,00	3	004400224
1/2x13	38,1 x 14	15,00	3	004400225
9/16x12	38,1 x 14	15,00	3	004400226
5/8x11	50,8 x 16	32,00	3	004400227
3/4x10	50,8 x 16	32,00	3	004400228
7/8x9	50,8 x 16	32,00	3	004400229
1"x8	50,8 x 16	32,00	3	004400230

440ASF

filire tonde, UNF
passo fine, in acciaio al cromo

UNI EN 2258
DIN 223

UNF	Ø x S mm	€		
1/4x28	25,4 x 9	11,60	5	004400241
5/16x24	25,4 x 9	11,60	5	004400242
3/8x24	38,1 x 14	16,50	3	004400243
7/16x20	38,1 x 14	16,50	3	004400244
1/2x20	38,1 x 14	16,50	3	004400245
9/16x18	38,1 x 14	16,50	3	004400246
5/8x18	50,8 x 16	33,50	3	004400247
3/4x16	50,8 x 16	33,50	3	004400248
7/8x14	50,8 x 16	33,50	3	004400249
1"x12	50,8 x 16	33,50	3	004400250

440ASG

filire tonde, filettatura GAS cilindrica
in acciaio al cromo

R ≤ 600 N/mm²



UNI EN 24231
DIN 223

GAS	Ø x S mm	€		
1/8x28	38,1 x 14	13,00	3	004400255
1/4x19	38,1 x 14	13,00	3	004400256
3/8x19	38,1 x 14	13,00	3	004400257
1/2x14	50,8 x 16	26,50	3	004400259
3/4x14	50,8 x 16	26,50	3	004400260
1"x11	63,5 x 19	52,50	3	004400261

441

filiere tonde **passo fine**
in acciaio al cromo

R ≤ 600 N/mm²
HRC ~ 60+61

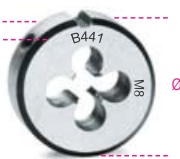

UNI 4535
DIN 223

M	Ø x S mm	€	🔧	📦
6x0,75	25,4 x 9	11,00	5	004410004
7x0,75	25,4 x 9	11,00	5	004410005
8x0,75	25,4 x 9	11,00	5	004410006
8x1	25,4 x 9	11,00	5	004410007
9x0,75	25,4 x 9	11,00	5	004410008
9x1	25,4 x 9	11,00	5	004410009

441A

filiere tonde **passo fine**
in acciaio al cromo

R ≤ 600 N/mm²
HRC ~ 60+61



UNI 4535
DIN 223

M	Ø x S mm	€	🔧	📦
10x0,75	38,1 x 14	16,50	3	004410100
10x1	38,1 x 14	16,50	3	004410101
10x1,25	38,1 x 14	16,50	3	004410102
11x0,75	38,1 x 14	16,50	3	004410103
11x1	38,1 x 14	16,50	3	004410104
11x1,25	38,1 x 14	16,50	3	004410105
12x0,75	38,1 x 14	16,50	3	004410106
12x1	38,1 x 14	16,50	3	004410107
12x1,25	38,1 x 14	16,50	3	004410108
12x1,5	38,1 x 14	16,50	3	004410109
14x1	38,1 x 14	16,50	3	004410110
14x1,25	38,1 x 14	16,50	3	004410111
14x1,5	38,1 x 14	16,50	3	004410112
16x1	38,1 x 14	16,50	3	004410113
16x1,5	38,1 x 14	16,50	3	004410114
18x1,5	38,1 x 14	16,50	3	004410115

441B

filiere tonde **passo fine**
in acciaio al cromo

R ≤ 600 N/mm²
HRC ~ 60+61



UNI 4535
DIN 223

M	Ø x S mm	€	🔧	📦
18x1,5	50,8 x 16	31,00	3	004410117
18x2	50,8 x 16	31,00	3	004410118
20x1,5	50,8 x 16	31,50	3	004410119
22x1,5	50,8 x 16	32,50	3	004410120
24x1,5	50,8 x 16	33,00	3	004410121
24x2	50,8 x 16	33,00	3	004410122

442

filiere tonde **passo grosso**
in acciaio HSS

HRC ~ 62+63
AISI M2



UNI EN 22568
DIN 223

M	Ø x S mm	€	🔧	📦
3x0,5	20x5	12,70	3	004420003
4x0,7	20x5	12,70	3	004420004
5x0,8	20x7	13,00	3	004420005
6x1	20x7	13,00	3	004420006
7x1	25x9	14,50	3	004420007
8x1,25	25x9	14,50	3	004420008
10x1,5	30x11	16,50	3	004420010
12x1,75	38x14	28,00	3	004420012
14x2	38x14	35,50	1	004420014
16x2	45x18	46,00	1	004420016
18x2,5	45x18	48,00	1	004420018
20x2,5	45x18	48,00	1	004420020
22x2,5	55x22	70,00	1	004420022
24x3	55x22	70,00	1	004420024

443

filiere tonde, **passo fine**
in acciaio HSS

HRC 62+63
AISI M2



UNI EN 22568
DIN 223

M	Ø x S mm	€	🔧	📦
6x0,75	20x7	22,00	1	004430107
8x0,75	25x9	24,00	1	004430110
8x1	25x9	23,00	1	004430111
10x0,75	30x11	30,00	1	004430113
10x1	30x11	26,50	1	004430114
10x1,25	30x11	26,50	1	004430115
12x1	38x10	44,00	1	004430116
12x1,25	38x10	44,00	1	004430117
12x1,5	38x10	44,00	1	004430118
13x1,5	38x10	52,00	1	004430119
14x1	38x10	44,00	1	004430120
14x1,25	38x10	44,00	1	004430121
14x1,5	38x10	44,00	1	004430122
15x1,5	38x10	58,50	1	004430123
16x1	45x14	64,00	1	004430124
16x1,5	45x14	64,00	1	004430125
18x1,5	45x14	64,00	1	004430127
20x1,25	45x14	66,50	1	004430129
20x1,5	45x14	66,50	1	004430130
20x2	45x14	66,50	1	004430131
22x1,5	55x16	80,00	1	004430132
24x1	55x16	83,00	1	004430133
24x1,5	55x16	83,00	1	004430135
24x2	55x16	88,00	1	004430136

444

girafilere, corpo in acciaio



EN 22568
DIN 225

	Ø mm	L mm	€	🔧	📦
444	20x5	190	17,40	5	004440005
444/0	20x7	190	17,40	5	004440007
444/1	25,4x9,5	210	18,10	5	004440025
444/1A	25x9	215	18,60	5	004440027
444/1B	30x11	250	21,30	5	004440030
444/C	38x10	310	27,50	3	004440033
444/1C	38x14	310	27,50	3	004440035
444/2	38,1x12,7	300	28,50	3	004440038
444/1D	45x14	445	38,50	1	004440045
444/2D	45x18	445	38,50	1	004440046
444/3	50,8x15,9	520	55,50	1	004440050
444/4	55x16	495	55,50	1	004440055
444/5A	63,5x19	520	96,00	1	004440057

444G

girafilere, corpo in lega leggera



UNI EN 22568
DIN 225

	Ø mm	L mm	€	🔧	📦
444G/A	16x5	160	8,20	5	004440103
444G	20x5	185	9,40	5	004440105
444G/0	20x7	185	9,40	5	004440107
444G/1	25,4x9,5	215	11,50	5	004440125
444G/1A	25x9	215	11,50	5	004440127
444G/1B	30x11	265	14,70	5	004440130
444G/C	38x10	315	21,20	3	004440133
444G/1C	38x14	315	21,20	3	004440135
444G/2	38,1x12,6	310	21,20	3	004440138
444G/1D	45x14	450	28,50	1	004440145
444G/2D	45x18	450	29,50	1	004440146
444G/3	50,8x16	485	30,50	1	004440150
444G/4	55x16	560	36,50	1	004440155
444G/5A	63,5x19	630	64,00	1	004440163
444G/6	65x18	630	68,00	1	004440165



446/C30

assortimento di maschi e filiere, in acciaio al cromo e accessori in cassetta di legno



446/C30 € 264,00 1 004460055

325x220x35 mm - 3,2 Kg

430 M	440 M		
3x0,5	3x0,5	435/1,5	444/1
4x0,7	4x0,7		
5x0,8	5x0,8		
6x1	6x1		
8x1,25	8x1,25		
10x1,5	10x1,5		
12x1,75	12x1,75		

446/C48

assortimento di maschi e filiere, in acciaio al cromo e accessori in cassetta di legno



446/C48 € 502,00 1 004460057

580x300x50 mm - 5 Kg

430 M	440 M	440A M		
3x0,5	3x0,5	10x1,5	435/1	444/1
4x0,7	4x0,7	12x1,75	435/3	444/2
5x0,8	5x0,8	14x2		
6x1	6x1	16x2		
8x1,25	8x1,25	18x2,5		
10x1,5		20x2,5		
12x1,75				
14x2				
16x2				
18x2,5				
20x2,5				

446/C110

assortimento di maschi e filiere, in acciaio al cromo e accessori per autoriparazione in cassetta di legno



446/C110 € 725,00 1 004460060

500x337x60 mm - 8,1 Kg

430 M	433 M	440/440A M	441/441A M
2x0,4	6x0,75	2x0,4	6x0,75
3x0,5	7x0,75	3x0,5	7x0,75
4x0,7	8x0,75	4x0,7	8x0,75
5x0,8	8x1	5x0,8	8x1
6x1	9x0,75	6x1	9x0,75
7x1	9x1	7x1	9x1
8x1,25	10x0,75	8x1,25	10x0,75
9x1,25	10x1	9x1,25	10x1
10x1,5	10x1,25	10x1,5	10x1,25
11x1,5	11x0,75	11x1,5	11x0,75
12x1,75	11x1	12x1,75	11x1
14x2	11x1,25	14x2	11x1,25
16x2	12x0,75	16x2	12x0,75
	12x1		12x1
	12x1,25		12x1,25
	12x1,5		12x1,5
	14x1		14x1
	14x1,25		14x1,25
	14x1,5		14x1,5
	16x1		16x1
	16x1,5		16x1,5
	18x1,5		18x1,5

435/0	444/1	436/1
435/3	444/2	

446ASF/C29

assortimento di maschi e filiere in acciaio al cromo e accessori filettatura UNF in cassetta di legno



446ASF/C29 € 575,00 1 004460070

660x410x50 mm - 6 Kg

433ASF	440ASF		
1/4	1/4	435/1,5	444/1
5/16	5/16	435/3	444/2
3/8	3/8		444/3
7/16	7/16		
1/2	1/2		
9/16	9/16		
5/8	5/8		
3/4	3/4		

446ASW/C36

assortimento di maschi e filiere in acciaio al cromo e accessori filettatura Whitworth in cassetta di legno



446ASW/C36 € 425,00 1 004460075

525x310x50 mm - 3,4 Kg

430ASW	440ASW		
1/8	1/8	435/1,5	444/1
5/32	5/32	435/2	444/2
3/16	3/16		
1/4	1/4		
5/16	5/16		
3/8	3/8		
7/16	7/16		
1/2	1/2		



446ASC/C37

assortimento di maschi e filiere
in acciaio al cromo e accessori
filettatura **UNC**
in cassetta di legno



446ASC/C37 € 614,00 1 004460080

660x410x50 mm - 6,7 Kg

430ASC	440ASC		
1/4	1/4	435/1,5	444/1
5/16	5/16	435/3	444/2
3/8	3/8		444/3
7/16	7/16		
1/2	1/2		
9/16	9/16		
5/8	5/8		
3/4	3/4		

446ASG/C23

assortimento di maschi e filiere
in acciaio al cromo e accessori
filettatura **GAS** cilindrica
in cassetta di legno



446ASG/C23 € 895,00 1 004460085

700x430x70 mm - 9,8 Kg

433ASG	440ASG		
1/8	1/8	435/3	444/2
1/4	1/4	435/5	444/3
3/8	3/8		444/5A
1/2	1/2		
3/4	3/4		
1"	1"		

447/C37

assortimento di maschi e filiere
in acciaio HSS e accessori
in cassetta di metallo



447/C37 € 539,00 1 004470055

380x185x35 mm - 3,9 Kg

431	442		
3x0,5	3x0,5	435/0	444
4x0,7	4x0,7	435/2	444/0
5x0,8	5x0,8		444/1A
6x1	6x1		444/1B
8x1,25	8x1,25		444/1C
10x1,5	10x1,5		
12x1,75	12x1,75		

436/1 0,5x3x75

447/C53

assortimento di maschi e filiere
in acciaio HSS e accessori
in cassetta di metallo



447/C53 € 1.110,00 1 004470060

500x235x50 mm - 9 Kg

431	442			
3x0,5	3x0,5	435/1,5	444	436/1
4x0,7	4x0,7	435/3	444/0	436/2
5x0,8	5x0,8		444/1A	
6x1	6x1		444/1B	
8x1,25	8x1,25		444/1C	
10x1,5	10x1,5		444/2D	
12x1,75	12x1,75			
14x2	14x2			
16x2	16x2			
18x2,5	18x2,5			
20x2,5	20x2,5			

447/C70

assortimento di maschi e filiere
in acciaio HSS e accessori
per autoriparazione ed industria
in cassetta di legno



447/C70 € 1.395,00 1 004470065

510x340x70 mm - 7,5 Kg

431	434	442	443
3x0,5	8x1	3x0,5	8x1
4x0,7	10x1,25	4x0,7	10x1,25
5x0,8	12x1,25	5x0,8	12x1,25
6x1	12x1,5	6x1	12x1,5
7x1	14x1,25	7x1	14x1,25
8x1,25	14x1,5	8x1,25	14x1,5
10x1,5	16x1,5	10x1,5	16x1,5
12x1,75		12x1,75	
14x2		14x2	
16x2		16x2	

435/0	444	436/1
435/3	444/0	
	444/1A	
	444/1B	
	444/C	
	444/1C	
	444/1D	
	444/2D	

450

seghe a tazza
in acciaio HSS-Co 8%

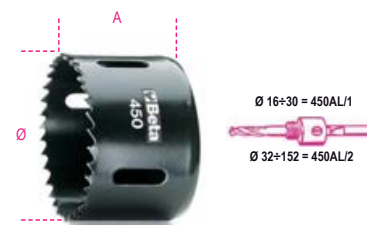

HSS-Co 8%

Ø mm	Ø	A mm	€		
16	(5/8)	57	14,00	1	004500016
17	(11/16)	57	14,00	1	004500017
19	(3/4)	51	14,00	1	004500019
20	-	51	14,00	1	004500020
21	(13/16)	51	14,00	1	004500021
22	(7/8)	51	14,00	1	004500022
24	(15/16)	51	14,00	1	004500024
25	(1")	51	15,20	1	004500025
27	(1 1/16)	51	15,80	1	004500027
29	(1 1/8)	51	15,80	1	004500029
30	(1 3/16)	51	15,80	1	004500030
32	(1 1/4)	51	15,80	1	004500032
33	(1 5/16)	51	16,30	1	004500033
35	(1 3/8)	51	18,30	1	004500035

Ø mm	Ø "	A mm	€		
37	(1"7/16)	51	18,30	1	004500037
38	(1"1/2)	44	18,80	1	004500038
40	(1"9/16)	44	19,30	1	004500040
41	(1"5/8)	44	19,80	1	004500041
43	(1"11/16)	44	19,80	1	004500043
44	(1"3/4)	44	20,50	1	004500044
46	(1"13/16)	44	20,50	1	004500046
48	(1"7/8)	44	21,00	1	004500048
51	(2")	44	21,80	1	004500051
52	(2"1/16)	44	24,30	1	004500052
54	(2"1/8)	44	24,30	1	004500054
57	(2"1/4)	44	24,30	1	004500057
59	(2"5/16)	44	25,00	1	004500059
60	(2"3/8)	44	25,00	1	004500060
64	(2"1/2)	44	26,50	1	004500064
65	(2"9/16)	44	26,50	1	004500065
67	(2"5/8)	44	26,50	1	004500067
68	-	44	26,50	1	004500068
70	(2"3/4)	44	27,50	1	004500070
73	(2"7/8)	44	27,50	1	004500073
76	(3")	44	28,50	1	004500076
79	(3"1/8)	44	30,00	1	004500079
83	(3"1/4)	44	31,50	1	004500083
86	(3"3/8)	44	31,50	1	004500086
89	(3"1/2)	44	32,50	1	004500089
92	(3"5/8)	44	34,50	1	004500092
95	(3"3/4)	44	36,00	1	004500095
98	(3"7/8)	44	37,00	1	004500098
102	(4")	44	38,50	1	004500102
105	(4"1/8)	44	41,50	1	004500105
108	(4"1/4)	44	52,00	1	004500108
111	(4"3/8)	44	59,50	1	004500111
114	(4"1/2)	44	70,00	1	004500114
121	(4"3/4)	44	77,50	1	004500121
127	(5")	44	85,50	1	004500127
140	(5"1/2)	44	103,00	1	004500140
152	(6")	44	120,00	1	004500152

450AL

alberi per seghe a tazza

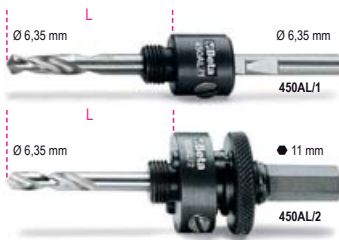

	Ø mm	L mm	€		
450AL/1	16÷30	54	17,00	1	004500210
450AL/2	32÷152	70	39,50	1	004500215

450AD

adattatore per alberi 450AL/1



	Ø mm	€		
450AD	32÷51	6,70	1	004500230



450PA/1

punta per centrare
in acciaio HSS
per alberi 450AL/1

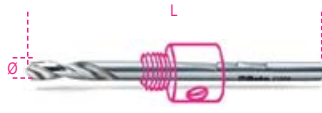

ØxL mm	€		
6,35x105	10,60	1	004500252

450PA/2

punta per centrare
in acciaio HSS
per alberi 450AL/2

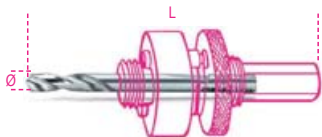

ØxL mm	€		
6,35x80	10,60	1	004500253

450PR

prolunga per seghe a tazza



L mm	€		
305	29,00	1	004500255

450/C9

assortimento di seghe a tazza
ed accessori per elettricisti



HSS-Co 8%

	€		
450/C9	202,00	1	004500305

450	Ø 22 - 29 - 35 - 44 - 51 - 64 mm
450AL	/1 - /2
450AD	
220x160x60 mm - 1,6 Kg	

450/C13

assortimento di seghe a tazza
ed accessori per installatori



HSS-Co 8%

	€		
450/C13	253,00	1	004500310

450	Ø 19 - 22 - 29 - 35 - 38 44 - 51 - 57 - 64 mm
450AL	/1 - /2
450PA/1	
450AD	
215x180x65 mm - 1,8 Kg	

450/C15

assortimento di seghe a tazza
ed accessori per elettricisti



	€		
450/C15	327,00	1	004500313

450	Ø 16 - 20 - 25 - 32 - 40 51 - 60 - 65 - 70 mm
450AL	/1 - /2
450PA	/1 - /2
450PR	
450AD	
420x185x60 mm - 3,2 Kg	



450/C21

assortimento di seghe a tazza ed accessori per uso industriale



HSS-Co 8%

450/C21 € 574,00 1 004500315

450 Ø 19 - 22 - 29 - 35 - 38
44 - 51 - 57 - 64 - 76
83 - 92 - 95 - 105 - 114 mm

450AL /1 - /2

450PA /1 - /2

450PR

450AD

420x280x60 mm - 7 Kg

451

frese a tazza in acciaio HSS interamente rettificate

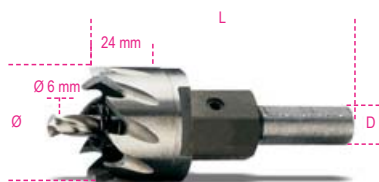

Ø mm	L mm	D mm	€	1	004510012
12	85	8	20,80	1	004510012
13	85	8	20,80	1	004510013
14	85	8	21,30	1	004510014
15	85	10	21,30	1	004510015
16	85	10	21,30	1	004510016
17	85	10	21,30	1	004510017
18	85	10	21,30	1	004510018
19	85	10	21,80	1	004510019
20	85	10	23,00	1	004510020
21	85	10	24,50	1	004510021
22	85	10	25,50	1	004510022
23	85	10	27,00	1	004510023
24	85	10	28,00	1	004510024
25	85	10	29,00	1	004510025
26	90	10	30,50	1	004510026
27	90	10	31,50	1	004510027
28	90	10	32,00	1	004510028
29	90	10	33,00	1	004510029
30	90	10	33,50	1	004510030
31	90	10	35,00	1	004510031
32	90	10	36,00	1	004510032
33	90	10	37,50	1	004510033
34	90	10	38,50	1	004510034
35	90	10	39,50	1	004510035
36	85	10	40,50	1	004510036
37	85	10	41,50	1	004510037
38	85	10	42,50	1	004510038
39	85	10	44,00	1	004510039
40	85	10	45,00	1	004510040
41	85	10	46,50	1	004510041
42	85	10	48,00	1	004510042
43	85	10	49,00	1	004510043
44	85	10	50,00	1	004510044
45	85	10	51,50	1	004510045
46	85	10	51,50	1	004510046
47	85	10	53,50	1	004510047
48	85	10	55,50	1	004510048
49	85	10	57,50	1	004510049
50	85	10	57,50	1	004510050

451GA

gambi per frese a tazza 451



M	Ø mm	L mm	D mm	€	1	004510101
10x1,25	12÷14	57	8	11,90	1	004510101
12x1,25	15÷34	57	10	11,90	1	004510102
14x1,5	35÷50	57	10	14,50	1	004510105

451PA

punta pilota per frese a tazza 451 in acciaio HSS



Ø mm	L mm	€	1	004510103
6	53	6,70	1	004510103

451PR

prolunga per frese a tazza 451



M	Ø mm	L mm	Ø1 mm	€	1	004510104
12x1,25	15÷34	400	13	52,00	1	004510104
14x1,5	35÷50	400	13	52,00	1	004510108

452

frese a tazza con inserti in metallo duro



Ø mm	Ø1 mm	€	1	004520015
15	10	86,00	1	004520015
16	10	86,00	1	004520016
17	10	86,00	1	004520017
18	10	86,00	1	004520018
19	10	86,00	1	004520019
20	10	86,00	1	004520020
21	10	86,00	1	004520021
22	10	86,00	1	004520022
23	10	86,00	1	004520023
24	10	86,00	1	004520024
25	10	86,00	1	004520025
26	10	96,50	1	004520026
27	10	96,50	1	004520027
28	10	96,50	1	004520028
29	10	96,50	1	004520029
30	10	96,50	1	004520030
31	10	116,00	1	004520031
32	10	116,00	1	004520032
33	10	116,00	1	004520033
34	10	116,00	1	004520034
35	10	116,00	1	004520035
36	10	135,00	1	004520036
37	10	135,00	1	004520037
38	10	135,00	1	004520038
39	13	135,00	1	004520039
40	13	135,00	1	004520040

Ø mm	Ø1 mm	€	1	004520041
41	13	152,00	1	004520041
42	13	152,00	1	004520042
43	13	152,00	1	004520043
44	13	152,00	1	004520044
45	13	152,00	1	004520045
46	13	171,00	1	004520046
47	13	171,00	1	004520047
48	13	171,00	1	004520048
49	13	171,00	1	004520049
50	13	171,00	1	004520050
55	13	194,00	1	004520055
60	13	257,00	1	004520060
65	13	257,00	1	004520065
70	13	300,00	1	004520070
75	13	326,00	1	004520075
80	13	355,00	1	004520080
85	13	400,00	1	004520085
90	13	425,00	1	004520090

452GA

gambi per frese a tazza 452



452GA/1	Ø mm	€	1	004520125
452GA/2	15÷21	10,70	1	004520125
452GA/3	22÷38	12,30	1	004520126
452GA/4	39÷100	14,70	1	004520127

460

frese perforatrici a tazza per edilizia

- Per calcestruzzo, cemento, pietre naturali e artificiali
- Profondità massima di foratura 60 mm

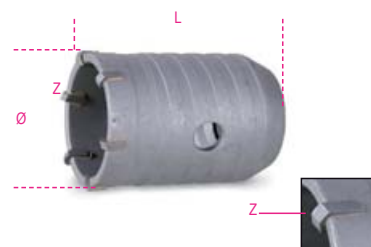

Ø mm	L mm	Z	€	1	004600050
50	75	6	44,00	1	004600050
60	75	6	52,00	1	004600060
65	75	6	54,50	1	004600065
80	75	6	80,50	1	004600080
90	75	6	85,50	1	004600090
100	75	8	104,00	1	004600100
112	75	8	119,50	1	004600112
125	80	10	148,50	1	004600125
150	80	12	200,00	1	004600150

460PP

punta pilota per frese a tazza per edilizia 460



Ø mm	L mm	€	1	004600201
8	120	4,90	1	004600201

460G

gambi per frese perforatrici a tazza 460



L mm	€		
220	27,00	1	004600222
370	38,00	1	004600237
460	60,00	1	004600246

560/C3

moltiplicatore di coppia destrorso/sinistrorso in valigetta di materiale plastico
rapporto 3,8:1
con dispositivo antiritorno

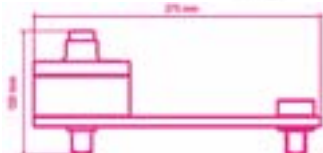

Nm	kgfm	lbf.ft	□	■	kg
1500	150	1110	1/2"	3/4"	3,9

560/C3	720,00	1	005600030
---------------	---------------	---	-----------

560/C3PLUS

moltiplicatore di coppia destrorso/sinistrorso in valigetta di materiale plastico
rapporto 3,8:1
con dispositivo antiritorno



Nm	kgfm	lbf.ft	□	■	kg
2700	270	1991	3/4"	1"	7,5

560/C3PLUS	840,00	1	005600038
-------------------	---------------	---	-----------

560/C2

moltiplicatore di coppia destrorso/sinistrorso e accessori
rapporto 5:1
in cassetta di plastica

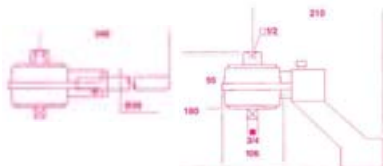

Nm	Kgfm	lbf.ft	□	■	kg
1300	130	960	1/2"	3/4"	3,8

560/C2	1.470,00	1	005600020
560/2	1.095,00	1	005600002
560/18	34,50	1	005600018
560/19	73,00	1	005600019
560/22	253,00	1	005600022

310x275x120 mm

560/C4+

moltiplicatore di coppia destrorso/sinistrorso e accessori
rapporto 5:1
con piede di reazione

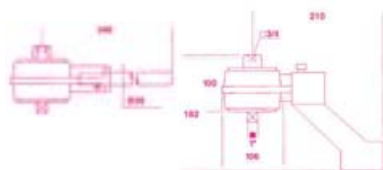
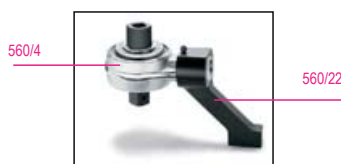

Nm	Kgfm	lbf.ft	□	■	kg
2700	270	2000	3/4"	1"	5

560/C4PLUS	1.440,00	1	005600042
560/4	1.135,00	1	005600004
560/18	34,50	1	005600018
560/22	253,00	1	005600022

310x275x120 mm

560/C6

moltiplicatore di coppia destrorso/sinistrorso in valigetta di materiale plastico
rapporto 6,5:1



Nm	kgfm	lbf.ft	□	■	kg
1500	150	1106	1/2"	3/4"	6

560/C6	749,00	1	005600160
---------------	---------------	---	-----------

400x260x110 mm

560/C12

moltiplicatore di coppia destrorso/sinistrorso in valigetta di materiale plastico
rapporto 12:1



Nm	kgfm	lbf.ft	□	■	kg
2500	250	1844	1/2"	1"	7

560/C12	1.080,00	1	005600210
----------------	-----------------	---	-----------

400x260x110 mm

561/1

moltiplicatore di coppia destrorso/sinistrorso
rapporto 5:1
con due piedi di reazione

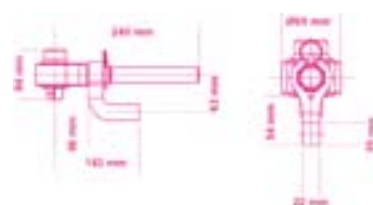

Nm	kgfm	lbf.ft	□	■	kg
1000	100	740	1/2"	3/4"	2,7

561/1	1.048,00	1	005610010
--------------	-----------------	---	-----------

270x210x70 mm

562/1 - 562/2

moltiplicatori di coppia destrorsi/sinistrorsi
rapporto 5:1



Nm	Kgfm	lbf.ft	□	■	D	A	L min	L max	kg
1700	170	1250	3/4	1"	108	95	85	220	5,3

562/1 € 2.280,00 1 005620001

Nm	Kgfm	lbf.ft	□	■	D	A	L min	L max	kg
3400	340	2500	3/4	1"	119	115	85	265	7,0

562/2 € 2.800,00 1 005620002

564/3R - 564/4R

moltiplicatori di coppia destrorsi/sinistrorsi
rapporto 25:1
con dispositivo antiritorno



Nm	Kgfm	lbf.ft	□	■	D	A	L	kg
3000	300	2200	1/2	1"	108	188	155	9,2

564/3R € 4.650,00 1 005640003

Nm	Kgfm	lbf.ft	□	■	D	A	L	kg
6000	600	4500	1/2	1 1/2"	119	235	200	15,5

564/4R € 5.530,00 1 005640004

565/1R - 565/2R - 565/3R

moltiplicatori di coppia destrorsi/sinistrorsi
rapporto 25:1
con dispositivo antiritorno



Nm	Kgfm	lbf.ft	□	■	D	A	L min	L max	kg
1700	170	1250	1/2	1"	108	125	80	215	7,7

565/1R € 3.820,00 1 005650011

Nm	Kgfm	lbf.ft	□	■	D	A	L min	L max	kg
3400	340	2500	1/2	1"	119	145	85	265	10,1

565/2R € 5.050,00 1 005650012

Nm	Kgfm	lbf.ft	□	■	D	A	L min	L max	kg
3400	340	2500	1/2	1 1/2"	119	145	85	265	10,7

565/3R € 5.350,00 1 005650013

565/4R

moltiplicatore di coppia destrorso/sinistrorso
rapporto 25:1
con dispositivo antiritorno

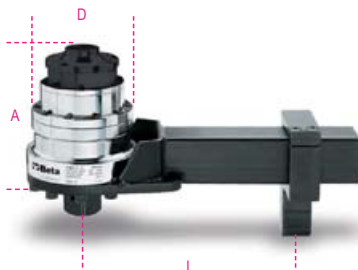

Nm	Kgfm	lbf.ft	□	■	D	A	L min	L max	kg
6000	600	4500	1/2	1 1/2"	144	180	125	335	17

565/4R € 5.990,00 1 005650014

565/5R

moltiplicatore di coppia destrorso/sinistrorso
rapporto 25:1
con dispositivo antiritorno

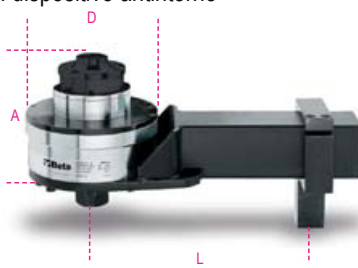

Nm	Kgfm	lbf.ft	□	■	D	A	L min	L max	kg
9500	950	7000	3/4	1 1/2"	184	180	155	355	25

565/5R € 10.400,00 1 005650015

567/4R

moltiplicatore di coppia destrorso/sinistrorso
rapporto 125:1
con dispositivo antiritorno



Nm	Kgfm	lbf.ft	□	■	D	A	L min	L max	kg
6000	600	4500	1/2	1 1/2"	144	210	125	335	19

567/4R € 6.690,00 1 005670014

567/5R

moltiplicatore di coppia destrorso/sinistrorso
rapporto 125:1
con dispositivo antiritorno

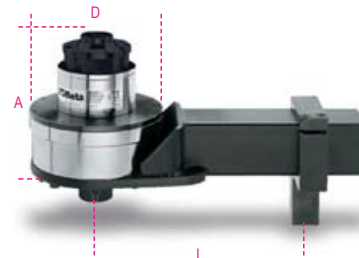

Nm	Kgfm	lbf.ft	□	■	D	A	L min	L max	kg
9500	950	7000	1/2	1 1/2"	184	210	155	350	27

567/5R € 11.690,00 1 005670015

562VV-A

valigia per moltiplicatori,
in polipropilene ad alta resistenza con spugna
Misure interne 380x270x180 mm



562VV-A € 199,00 1 005620501

562/1-562/2-564/3R
564/4R-565/1R-565/2R
565/3R

410x340x205 mm - 3,5 kg

565VV-B

valigia per moltiplicatori,
in polipropilene ad alta resistenza con spugna
Misure interne 480x370x205 mm



565VV-B € 270,00 1 005650502

565/4R-565/5R
567/4R-567/5R

520x435x230 mm - 5,4 kg

Beta

581

giravite dinamometrico a slittamento, non graduato adatto a serraggi destrorsi, precisione di serraggio +/-6% (per il settaggio della coppia usare gli artt. 588 - 682)



UNI EN ISO 6789

Nm	gfm	lbf.in	A mm	L mm	kg
1,2÷6	120÷600	1/4"	60	253	0,275

581 € 235,00 1 005810001

583

giravite dinamometrico a slittamento adatto a serraggi destrorsi, precisione di serraggio +/-6%



UNI EN ISO 6789

Nm	gfm	lbf.in	A mm	L mm	kg
0,3÷1,5	30÷150	1/4"	60	240	0,240

583/1,5 € 264,00 1 005830015

Nm	gfm	lbf.in	A mm	L mm	kg
0,6÷3	60÷300	1/4"	60	240	0,240

583/3 € 264,00 1 005830030

Nm	gfm	lbf.in	A mm	L mm	kg
1,2÷6	120÷600	1/4"	60	350	0,350

583/6 € 264,00 1 005830060

583/C31

1 giravite dinamometrico, 8 chiavi a bussola esagonali, 20 inserti per avvitatori e 2 accessori

1/4



583/C31 € 367,00 1 005830931

583/6	1.2 - 6 Nm
900	4-5-5,5-6-7-8-9-10 mm
860LP	0,6x4,5 - 1x5,5 - 1,2x6,5 mm
860PH	PH1 - PH2 (x2) - PH3
860PE	2-2,5-3-4-5 mm
860TX	T9-T10-T15-T20-T25-T27-T30-T40
882P/80	80 mm
892/0	● 1/4 ■ 1/4

270x120x45 mm - 1,2 kg

588

misuratore di coppia elettronico digitale

per la verifica e il settaggio dei giravite dinamometrici art. 581-583

Precisione di lettura: ± 1% del valore letto

CE



Nm	lbf.in	lbf.ft	A mm	L mm	kg
1÷10	10÷90	1/4"	70	253	1,8

588 € 1.780,00 1 005880001

Tabella dei campi di impiego delle chiavi e barre dinamometriche a fine listino



590 - 592

chiavi dinamometriche a lettura diretta adatte a serraggi destrorsi e sinistrorsi precisione di serraggio ± 4%

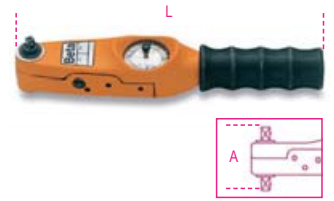

UNI EN ISO 6789

Nm	Kgfm	lbf.in	A mm	L mm	kg
0,3÷4	0,03÷0,4	3÷35	1/4	60	0,52

590 € 625,00 1 005900001

Nm	Kgfm	lbf.in	A mm	L mm	kg
0,5÷13,5	0,05÷1,35	4÷120	1/4	60	0,52

590/1 € 625,00 1 005900003

Nm	Kgfm	lbf.in	A mm	L mm	kg
1÷27	0,1÷2,7	10÷240	3/8	70	0,52

592/3 € 620,00 1 005920005

Nm	Kgfm	lbf.in	A mm	L mm	kg
3÷40	0,3÷4	20÷360	3/8	70	0,52

592/4 € 620,00 1 005920007

594

chiavi dinamometriche a lettura diretta adatte a serraggi destrorsi e sinistrorsi precisione di serraggio ± 4%

12"

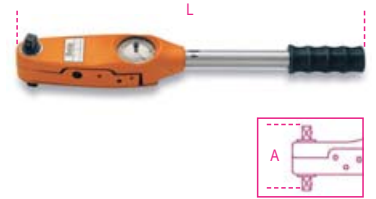

UNI EN ISO 6789

Nm	Kgfm	lbf.ft	A mm	L mm	kg
6÷80	0,6÷8	5÷60	1/2	85	1,35

594/8 € 940,00 1 005940011

Nm	Kgfm	lbf.ft	A mm	L mm	kg
20÷215	2÷21,5	15÷160	1/2	85	1,40

594/21 € 940,00 1 005940015

Servizio di taratura dinamometrica a fine listino

596 - 598

chiavi dinamometriche a lettura diretta adatte a serraggi destrorsi e sinistrorsi precisione di serraggio $\pm 4\%$

Il raggiungimento della coppia prefissata viene segnalato da una luce e da un suono intermittente

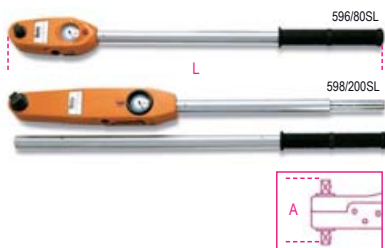

UNI EN ISO 6789

Nm	Kgfm	lbf.ft	■	A mm	L mm	kg
80÷400	8÷40	60÷300	3/4	111	710	3,2

596/40SL € 1.550,00 1 005960010

Nm	Kgfm	lbf.ft	■	A mm	L mm	kg
160÷800	16÷80	120÷600	3/4	115	1025	4,85

596/80SL € 1.960,00 1 005960020

Nm	Kgfm	lbf.ft	■	A mm	L mm	kg
400÷2000	40÷200	300÷1500	1"	135	1930	16,70

598/200SL € 4.070,00 1 005980022

599DGT

chiave dinamometrica elettronica con cricchetto reversibile, per serraggi destrorsi e sinistrorsi precisione di serraggio $\pm 2\%$ destrorso, $\pm 3\%$ sinistrorso

- Doppia modalità di misura: picco e traccia
- Il raggiungimento della coppia prefissata viene segnalato da avvisatori luminosi e da un suono intermittente
- Alimentazione con 2 batterie da 1,5V (incluse)



UNI EN ISO 6789

Nm	Kgfm	lbf.ft	■	D mm	A mm	L mm	kg
12÷60	1,2÷6	8÷44	3/8	30	33	413	0,9

599DGT/6 € 330,00 1 005990003

Nm	Kgfm	lbf.ft	■	D mm	A mm	L mm	kg
20÷100	2÷10	15÷80	1/2	30	37	413	0,9

599DGT/10X € 340,00 1 005990010

Nm	Kgfm	lbf.ft	■	D mm	A mm	L mm	kg
40÷200	4÷20	30÷150	1/2	40	43	520	2

599DGT/20 € 353,00 1 005990020

Nm	Kgfm	lbf.ft	■	D mm	A mm	L mm	kg
68÷340	6,8÷34	58÷280	1/2	40	43	640	2,35

599DGT/30 € 380,00 1 005990030

599DGT-AN

chiave dinamometrica elettronica a lettura di coppia e angolo con cricchetto reversibile, per serraggi destrorsi (precisione $\pm 2\%$) e sinistrorsi (precisione $\pm 3\%$)

- Tipologie di serraggio: coppia, angolo, coppia + angolo
- Doppia modalità di misura: picco e traccia
- Il raggiungimento della coppia o dell'angolo prefissati vengono segnalati da avvisatori luminosi e da un suono intermittente
- Memorizzazione dei dati di serraggio (fino a 1600 valori)
- 9 valori di coppia/angolo preimpostabili
- Blocco di sicurezza dei tasti
- Possibilità di associare la chiave a 16 utilizzatori tramite ID utente
- Tracciabilità dei dati di serraggio. Il software permette di memorizzare data e ora, numero di serie dell'utensile, valore di serraggio impostato, valore raggiunto, e di associarli all'ID utente
- Impugnatura bimatériauale antiscivolo
- Inclusi: 2 batterie AA - 1,5V, cavo USB e software



UNI EN 26789
ISO 6789

Nm	Kgfm	lbf.ft	■	D mm	A mm	L mm	kg
20÷100	2÷10	15÷80	1/2	30	33	413	0,9

599DGT-AN/10 € 620,00 1 005990610

Nm	Kgfm	lbf.ft	■	D mm	A mm	L mm	kg
40÷200	4÷20	30÷150	1/2	40	43	520	1,3

599DGT-AN/20 € 655,00 1 005990620

Servizio di taratura
dinamometria
a fine listino

600

attrezzi per serraggi angolari



	□	■	€	1	006000001
600/1	1/2	1/2	132,00	1	006000001
600/2	3/4	3/4	150,00	1	006000002

601C

goniometro digitale per serraggi angolari, magnetico il raggiungimento dell'angolo prefissato viene segnalato da avvisatori luminosi e da un suono intermittente



	□	■	€	1	006010100
601C			178,00	1	006010100

85x80x87 mm - 70 g

601CA

goniometro digitale per serraggi coppia ed angolo il raggiungimento della coppia o dell'angolo prefissati viene segnalato da avvisatori luminosi e da un suono intermittente



	□	■	Nm	€	1	006010120
601CA	1/2"	1/2"	10÷200	314,00	1	006010120

120x90x120 mm - 240 g

603

chiavi dinamometriche a slittamento
per serraggi destrorsi
precisione di serraggio $\pm 6\%$



UNI EN ISO 6789

Nm	Kgfm	lbf.in	■	A	L	g
1÷5	0,1÷0,5	10÷45	1/4	35	195	235

603/5	€ 535,00	1	006030005
-------	----------	---	-----------

Nm	Kgfm	lbf.in	■	A	L	g
2÷10	0,2÷1,0	18÷90	1/4	35	195	235

603/10	€ 548,00	1	006030010
--------	----------	---	-----------

604B

barre dinamometriche a disinnesto
per serraggi destrorsi e sinistrorsi
precisione di serraggio $\pm 6\%$



UNI EN ISO 6789

Nm	kgfm	lbf.in	∅	L	g
1÷5	0,1÷0,5	10÷45	8	220	290

604B/5	€ 348,00	1	006040015
--------	----------	---	-----------

Nm	Kgfm	lbf.in	∅	L	g
2÷10	0,2÷1,0	18÷90	8	220	300

604B/10	€ 348,00	1	006040020
---------	----------	---	-----------

605E

chiavi dinamometriche a scatto
con cricchetto reversibile
per serraggi destrorsi e sinistrorsi
precisione di serraggio $\pm 6\%$



UNI EN ISO 6789

Nm	Kgfm	lbf.in	■	A	L	g
1÷5	0,1÷0,5	10÷45	1/4	20	190	180

605E/5	€ 179,00	1	006050105
--------	----------	---	-----------

Nm	Kgfm	lbf.in	■	A	L	g
2÷10	0,2÷1,0	18÷90	1/4	20	190	180

605E/10	€ 187,00	1	006050110
---------	----------	---	-----------

611

cricchetti reversibili
per barre dinamometriche 604B/5 e 604B/10



■	L	€	g
1/4	42,5	€ 125,00	1 006110001

Servizio di taratura
dinamometria
a fine listino

612 ÷ 614

cricchetti reversibili
per barre dinamometriche



Gli articoli 612 e 612X non devono
essere utilizzati con coppie di serraggio
superiori a 100 Nm

612	612X	614	614X	■	L	LA	€	g
				3/8	66	32	56,50	2 006120000
				1/2	66	32	60,00	2 006120010
				1/2	71	32	65,00	2 006140000
				3/4	71	32	71,50	2 006140004

614/50

cricchetto semplice
per barre dinamometriche



614/50	■	L	LA	€	g
	1/2	71	32	€ 60,00	2 006140002

Meccanismi rotanti
di ricambio dei cricchetti,
vedi tabella dopo l'art. 929/C8

615

cricchetti reversibili
per barre dinamometriche
con attacco rettangolare



■	L	LA	€	g	
9x12	3/8	53	28,8	47,50	1 006150010
9x12	1/2	53	28,8	47,50	1 006150020
14x18	1/2	70	39,8	47,50	1 006150120

616 - 617 - 619

quadri maschi
per barre dinamometriche



616	617	619	■	L	LA	€	g
			1/4	61	32	45,00	1 006160000
			3/8	61	32	45,00	1 006170000
			1/2	63	32	45,00	1 006190000

621

accessori portainseri
per barre dinamometriche
con attacco rettangolare,
con magnete



P	■	L	LA	€	g	
P 1/4	9x12	1/4	40	28,8	57,00	1 006210000
* P 5/16	14x18	5/16	61	32,5	87,00	1 006210110

*Attenzione! Ricalcolare il valore di coppia da impostare
come indicato nella tabella in fondo al listino

641

chiavi a forchetta
per barre dinamometriche 604B/5 e 604B/10



641	■	L	€	g
	4	37	67,50	1 006410003
	5	37	67,50	1 006410004
	5,5	37	67,50	1 006410005
	6	37	67,50	1 006410006
	7	37	67,50	1 006410007
	8	42	67,50	1 006410008
	9	42	67,50	1 006410009
	10	42	67,50	1 006410010

659/16

raccordo con attacco rettangolare femmina 9x12 mm e maschio 14x18 mm



L	□	■	LA	€	📦	📄
mm	mm	mm	mm			
52	9x12	14x18	31	55,50	1	006590816

*Attenzione! Ricalcolare il valore di coppia da impostare come indicato nella tabella in fondo al listino

665

chiave dinamometrica meccanica a lettura digitale con cricchetto reversibile, per serraggi destrorsi, precisione di serraggio ± 3%

- Impostazione e lettura semplice della coppia tramite valore visualizzato sul display
- Il display rimane acceso con valore di coppia impostato
- Lettura della coppia con cifra decimale
- Spegnimento automatico dopo 10 sec. con impostazione della coppia inferiore alla soglia minima
- Alimentazione con 1 batteria da 3 V (inclusa)



UNI EN ISO 6789

Nm	■	D	A	L	g
		mm	mm	mm	
10÷60	3/8	30	33	335	655

665/6	198,00	1	006650006
-------	--------	---	-----------

Nm	■	D	A	L	g
		mm	mm	mm	
20÷100	3/8	30	33	375	725

665/10	199,50	1	006650010
--------	--------	---	-----------

Nm	■	D	A	L	g
		mm	mm	mm	
20÷100	1/2	30	37	375	725

665/10X	204,00	1	006650011
---------	--------	---	-----------

Nm	■	D	A	L	g
		mm	mm	mm	
40÷200	1/2	40	43	470	995

665/20	217,00	1	006650020
--------	--------	---	-----------

Nm	■	D	A	L	g
		mm	mm	mm	
60÷330	1/2	40	43	590	1260

665/30	247,00	1	006650030
--------	--------	---	-----------

Beta
Quality Tools

665LB

chiave dinamometrica meccanica a lettura digitale con cricchetto reversibile, per serraggi destrorsi, precisione di serraggio ± 3%

- Unità di misura: lbf.ft
- Impostazione e lettura semplice della coppia tramite valore visualizzato sul display
- Il display rimane acceso con valore di coppia impostato
- Lettura della coppia con cifra decimale
- Spegnimento automatico dopo 10 sec. con impostazione della coppia inferiore alla soglia minima
- Alimentazione con 1 batteria da 3 V (inclusa)



UNI EN ISO 6789

lbf.ft	■	D	A	L	g
		mm	mm	mm	
7÷45	3/8	30	33	335	655

665LB/6	198,00	1	006650106
---------	--------	---	-----------

lbf.ft	■	D	A	L	g
		mm	mm	mm	
15÷75	3/8	30	33	375	725

665LB/10	199,50	1	006650110
----------	--------	---	-----------

lbf.ft	■	D	A	L	g
		mm	mm	mm	
15÷75	1/2	30	37	375	725

665LB/10X	204,00	1	006650111
-----------	--------	---	-----------

lbf.ft	■	D	A	L	g
		mm	mm	mm	
30÷150	1/2	40	43	470	995

665LB/20	217,00	1	006650120
----------	--------	---	-----------

lbf.ft	■	D	A	L	g
		mm	mm	mm	
45÷240	1/2	40	43	590	1260

665LB/30	247,00	1	006650130
----------	--------	---	-----------

665SW

dispositivo di calibrazione

- Il dispositivo permette la calibrazione delle chiavi serie 665 con l'ausilio dei misuratori di coppia Beta 680 e 682, senza la necessità di smontare la chiave.
- La calibrazione avviene su più punti per compensare il comportamento non lineare della molla.
- Dotato di presa Micro USB per consentire futuri aggiornamenti firmware.



665SW	20,00	1	006650100
-------	-------	---	-----------

666N

chiavi dinamometriche a scatto con cricchetto reversibile per serraggi destrorsi precisione di serraggio ± 3%



UNI EN ISO 6789

Nm	Kgfm	lbf.ft	■	D	A	L	g
				mm	mm	mm	
5÷25	0,5÷2,5	4÷18	1/4	25	29	220	300

666N/2	268,00	1	006660002
--------	--------	---	-----------

Nm	Kgfm	lbf.ft	■	D	A	L	g
				mm	mm	mm	
5÷25	0,5÷2,5	4÷18	3/8	25	29	220	300

666N/2X	274,00	1	006660003
---------	--------	---	-----------

Nm	Kgfm	lbf.ft	■	D	A	L	g
				mm	mm	mm	
10÷50	1÷5	7÷37	3/8	30	33	325	680

666N/5	198,00	1	006660005
--------	--------	---	-----------

Nm	Kgfm	lbf.ft	■	D	A	L	g
				mm	mm	mm	
20÷100	2÷10	15÷75	3/8	30	33	367	730

666N/10	199,50	1	006660010
---------	--------	---	-----------

Nm	Kgfm	lbf.ft	■	D	A	L	g
				mm	mm	mm	
20÷100	2÷10	15÷75	1/2	30	37	367	800

666N/10X	204,00	1	006660011
----------	--------	---	-----------

Nm	Kgfm	lbf.ft	■	D	A	L	g
				mm	mm	mm	
40÷200	4÷20	30÷150	1/2	40	43	465	1010

666N/20	217,00	1	006660020
---------	--------	---	-----------

Nm	Kgfm	lbf.ft	■	D	A	L	g
				mm	mm	mm	
60÷300	6÷30	50÷220	1/2	40	43	581	1380

666N/30	247,00	1	006660030
---------	--------	---	-----------



Beta

666N LBF.IN

chiavi dinamometriche a scatto
con cricchetto reversibile
per serraggi destrorsi
precisione di serraggio $\pm 3\%$
• Scala in libbre-forza per pollice



UNI EN ISO 6789

lbf.in	■	D	A	L	g
90÷440	3/8	mm 30	mm 33	mm 325	660

666N-LBF.IN/5 € 198,00 1 006660055

lbf.in	■	D	A	L	g
200÷900	3/8	mm 30	mm 33	mm 367	730

666N-LBF.IN/10 € 199,50 1 006660070

lbf.in	■	D	A	L	g
200÷900	1/2	mm 30	mm 37	mm 367	800

666N-LBF.IN/10X € 204,00 1 006660071

lbf.in	■	D	A	L	g
400÷1800	1/2	mm 40	mm 43	mm 465	1010

666N-LBF.IN/20 € 217,00 1 006660072

lbf.in	■	D	A	L	g
500÷3000	1/2	mm 40	mm 43	mm 581	1380

666N-LBF.IN/30 € 247,00 1 006660073

667N

chiavi dinamometriche a scatto
con cricchetto semplice
per serraggi destrorsi e sinistrorsi
precisione di serraggio $\pm 3\%$



UNI EN ISO 6789

Nm	Kgfm	lbf.ft	■	D	A	L	g
40÷200	4÷20	30÷150	1/2	mm 40	mm 43	mm 465	1010

667N/20 € 213,00 1 006670020

Nm	Kgfm	lbf.ft	■	D	A	L	g
60÷300	6÷30	50÷220	1/2	mm 40	mm 43	mm 581	1380

667N/30 € 238,00 1 006670030

Nm	Kgfm	lbf.ft	■	D	A	L	g
80÷400	8÷40	60÷295	3/4	mm 50	mm 50	mm 687	2090

667N/40 € 572,00 1 006670040

**Meccanismi rotanti
di ricambio dei cricchetti,
vedi tabella dopo l'art. 929/C8**

668N

barre dinamometriche a scatto
per serraggi destrorsi e sinistrorsi
precisione di serraggio $\pm 3\%$



UNI EN ISO 6789

Nm	Kgfm	lbf.ft	Ø	L	LB	LS	g
5÷25	0,5÷2,5	4÷18	mm 16	mm 220	mm 148	mm 32	300

668N/2 € 199,50 1 006680002

Nm	Kgfm	lbf.ft	Ø	L	LB	LS	g
10÷50	1÷5	7÷37	mm 16	mm 332	mm 229	mm 32	590

668N/5 € 196,00 1 006680005

Nm	Kgfm	lbf.ft	Ø	L	LB	LS	g
20÷100	2÷10	15÷75	mm 16	mm 362	mm 269	mm 32	670

668N/10 € 199,50 1 006680010

Nm	Kgfm	lbf.ft	Ø	L	LB	LS	g
40÷200	4÷20	30÷150	mm 16	mm 445	mm 352,6	mm 32	795

668N/20 € 217,00 1 006680020

Nm	Kgfm	lbf.ft	Ø	L	LB	LS	g
60÷300	6÷30	50÷220	mm 16	mm 569	mm 475,9	mm 32	1230

668N/30 € 247,00 1 006680030

668RG

barra dinamometrica a scatto,
non graduata

adatta a serraggi destrorsi e sinistrorsi
precisione di serraggio $\pm 4\%$
(per il settaggio della coppia usare gli art.
680/40 - 682)



UNI EN ISO 6789

Nm	Kgfm	lbf.ft	Ø	L	g
8÷60	0,8÷6	6÷44	mm 16	mm 288	550

668RG/6 € 161,00 1 006680206

Nm	Kgfm	lbf.ft	Ø	L	g
20÷100	2÷10	15÷80	mm 16	mm 315	600

668RG/10 € 165,00 1 006680210

Nm	Kgfm	lbf.ft	Ø	L	g
40÷200	4÷20	30÷150	mm 16	mm 405	780

668RG/20 € 176,00 1 006680220

Nm	Kgfm	lbf.ft	Ø	L	g
60÷300	6÷30	50÷220	mm 16	mm 645	1130

668RG/30 € 197,00 1 006680230

668RGC

chiave dinamometrica a scatto,
non graduata

con cricchetto reversibile
adatta a serraggi destrorsi
precisione di serraggio $\pm 4\%$
(per il settaggio della coppia usare gli art.
680/40 - 682)



UNI EN ISO 6789

Nm	Kgfm	lbf.in	■	D	A	L	g
12÷60	1,2÷6	5÷45	3/8	mm 30	mm 33	mm 295	600

668RGC/6 € 147,00 1 006680406

Nm	Kgfm	lbf.in	■	D	A	L	g
20÷100	2÷10	15÷75	3/8	mm 30	mm 33	mm 335	700

668RGC/10 € 153,50 1 006680410

Nm	Kgfm	lbf.in	■	D	A	L	g
20÷100	2÷10	15÷75	1/2	mm 40	mm 43	mm 342	700

668RGC/10X € 153,50 1 006680411

Nm	Kgfm	lbf.in	■	D	A	L	g
40÷200	4÷20	30÷150	1/2	mm 40	mm 43	mm 425	1000

668RGC/20 € 156,00 1 006680420



669N

barra dinamometriche a scatto, attacco rettangolare per serraggi destrorsi e sinistrorsi precisione di serraggio $\pm 3\%$



UNI EN ISO 6789

Nm	Kgfm	lbf.ft	□ mm	L mm	LB mm	LS mm	g
5÷25	0,5÷2,5	4÷18	9x12	215	140	28,8	300

669N/2	€ 284,00	1	006690202
---------------	-----------------	---	-----------

Nm	Kgfm	lbf.ft	□ mm	L mm	LB mm	LS mm	g
10÷50	1÷5	7÷37	9x12	322	226,8	28,8	590

669N/5	€ 219,00	1	006690205
---------------	-----------------	---	-----------

Nm	Kgfm	lbf.ft	□ mm	L mm	LB mm	LS mm	g
20÷100	2÷10	15÷75	9x12	362	266,8	28,8	670

669N/10	€ 235,00	1	006690210
----------------	-----------------	---	-----------

Nm	Kgfm	lbf.ft	□ mm	L mm	LB mm	LS mm	g
40÷200	4÷20	30÷150	9x12	445	345,6	28,8	795

669N/20	€ 282,00	1	006690220
----------------	-----------------	---	-----------

Nm	Kgfm	lbf.ft	□ mm	L mm	LB mm	LS mm	g
40÷200	4÷20	30÷150	14x18	445	351	39,8	795

669N/20X	€ 298,00	1	006690221
-----------------	-----------------	---	-----------

Nm	Kgfm	lbf.ft	□ mm	L mm	LB mm	LS mm	g
60÷300	6÷30	50÷220	14x18	569	468,5	39,8	1230

669N/30	€ 314,00	1	006690230
----------------	-----------------	---	-----------

Nm	Kgfm	lbf.ft	□ mm	L mm	LB mm	LS mm	g
80÷400	8÷40	60÷295	14x18	588	563	39,8	2100

669N/40	€ 362,00	1	006690240
----------------	-----------------	---	-----------

671B/C5

barra dinamometrica 604B/5 e accessori

14" 16



671B/C5	€ 795,00	1	006710001
----------------	-----------------	---	-----------

604B/5	1÷5 Nm
611	1/4
641	5-6-7-8 mm
900	4-5-5,5-6-7-8-9-10 mm

270x120x45 mm - 1,3 kg

671B/C10

barra dinamometrica 604B/10 e accessori

14" 16



671B/C10	€ 795,00	1	006710002
-----------------	-----------------	---	-----------

604B/10	2÷10 Nm
611	1/4
641	6-7-8-10 mm
900	4-5-5,5-6-7-8-9-10 mm

270x120x45 mm - 1,4 kg

671N/C10

barra dinamometrica 668N/10 e accessori

38" 16



671N/C10	€ 896,00	1	006710110
-----------------	-----------------	---	-----------

668N/10	100 Nm
612	3/8
617	3/8
642	10-13-14-17-19 mm
652	10-13-14-17-19 mm
910A	3/8 8-10-11-13-14-17-19 mm
910/21	125 mm
910/22	250 mm

400x180x45 mm - 4,3 kg

671N/C20

barra dinamometrica 668N/20 e accessori

12" 16



671N/C20	€ 949,00	1	006710120
-----------------	-----------------	---	-----------

668N/20	200 Nm
614	1/2
619	1/2
642	10-13-14-17-19 mm
652	10-13-14-17-19 mm
920A	1/2 10-11-13-14-17-19-22 mm
920/20	75 mm
920/21	125 mm
920/22	255 mm

510x180x45 mm - 5,5 kg

671N/C30

barra dinamometrica 668N/30 e accessori

12" 16



671N/C30	€ 900,00	1	006710130
-----------------	-----------------	---	-----------

668N/30	300 Nm
614	1/2
619	1/2
642	13-14-17-19 mm
652	13-14-17-19 mm
920A	1/2 13-14-17-19-22-24-27 mm
920/20	75 mm
920/21	125 mm
920/22	255 mm

620x180x45 mm - 5,8 kg

677

chiavi dinamometriche a disinnesto con cricchetto semplice per serraggi destrorsi e sinistrorsi precisione di serraggio $\pm 4\%$

34" 16



UNI EN ISO 6789

Nm	Kgfm	lbf.ft	D mm	A mm	L mm	g
100÷500	10÷50	70÷350	70	55	915	5,2

677/50	€ 667,00	1	006770050
---------------	-----------------	---	-----------

Nm	Kgfm	lbf.ft	D mm	A mm	L mm	g
150÷700	15÷70	100÷500	70	55	1140	6,2

677/70	€ 699,00	1	006770070
---------------	-----------------	---	-----------



Nm	Kgfm	lbf.ft	D	A	L	kg
300÷1000	30÷100	200÷750	70	55	1470	7,5

677/100 € 727,00 1 006770100

677/C

chiavi dinamometriche a disinnesto con cricchetto semplice per serraggi destrorsi e sinistrorsi precisione di serraggio ± 4% in cassetta



UNI EN ISO 6789

Nm	Kgfm	lbf.ft	D	A	L	kg
100÷500	10÷50	70÷350	70	55	915	5,2

677/C50 € 790,00 1 006770606

Nm	Kgfm	lbf.ft	D	A	L	kg
150÷700	15÷70	100÷500	70	55	1140	6,2

677/C70 € 822,00 1 006770611

Nm	Kgfm	lbf.ft	D	A	L	kg
300÷1000	30÷100	200÷750	70	55	1470	7,5

677/C100 € 962,00 1 006770615

Nm	Kgfm	lbf.ft	D	A	L	kg
700÷1500	70÷150	500÷1000	70	70	1475	10,4

677/C150 € 1.235,00 1 006770620

677/CP200

chiavi dinamometriche a disinnesto con cricchetto semplice per serraggi destrorsi e sinistrorsi precisione di serraggio ± 4% in cassetta



UNI EN ISO 6789

Nm	kgfm	lbf.in	D	A	L	kg
900÷2000	90÷200	600÷1500	70	63	1920	13

677/CP200 € 2.250,00 1 006770720

678/C

chiavi dinamometriche a scatto con cricchetto semplice per serraggi destrorsi e sinistrorsi precisione di serraggio ± 4% in cassetta

• Modelli 678/C100 e 678/C150 forniti di prolunga.



UNI EN ISO 6789

Nm	Kgfm	lbf.ft	D	A	L	kg
130÷650	13÷65	100÷480	63	55	885	3,9

678/C65 € 1.335,00 1 006780607

Nm	Kgfm	lbf.ft	D	A	L	kg
300÷1000	30÷100	220÷750	75	60	1250	6,0

678/C100 € 1.780,00 1 006780611

Nm	Kgfm	lbf.ft	D	A	L	kg
500÷1500	50÷150	370÷1100	75	60	1570	8,5

678/C150 € 1.970,00 1 006780615

677/CV - 678/CV

cassette vuote per chiavi dinamometriche 677 e 678



677/CV1 € 123,00 1 006770450
677/C50-677/C70

678/CV1 € 95,00 1 006780455

678/C65 € 115,00 1 006780500

678/CV2 € 115,00 1 006780500

678/C100 € 235,00 1 006780415

678/CV3 € 235,00 1 006780415

677/C100-677/C150-678/C150

680

misuratore di coppia elettronico digitale Dynatester 680 per verifica tarature funzionamento destrorso e sinistrorso

• Precisione di lettura: ± 1% del valore letto
• 3 unità di misura: Nm - lbf.ft. - lbf.in

CE



	Nm	kg	€		
680/2,5	1÷25	2,6	1.755,00	1	006800002
680/40	15÷400	4,0	1.765,00	1	006800040
680/100	100÷1000	4,8	2.530,00	1	006800100

682

misuratore di coppia elettronico digitale con trasduttori porziometrici Dynatester 682 funzionamento destrorso e sinistrorso

Alta precisione di lettura
Fornito di uscita seriale RS 232



CARATTERISTICHE TECNICHE:

Precisione di lettura: ± 1% del valore letto

Unità di misura selezionabili

Nm-dNm-cNm-lbf.ft-lbf.in-Ozf.in-Kgf.m-Kgf.cm-gf.cm

Alimentazione: 90 a 264V AC a 50/60 Hz

Dimensioni: 235x185x185 mm

Verifica di tolleranza secondo norma ISO6789

Indicazione dell'intervallo di accettabilità specifico per ogni chiave dinamometrica testata

Display: Menu selezionabile in 11 lingue

Documentazione allegata

Certificato di calibrazione con rintracciabilità UKAS

	Nm	kg	€		
682/60	1,2÷60	5,9	4.730,00	1	006820006
682/400	8÷400	6,1	4.800,00	1	006820040
682/1500	30÷1500	6,4	4.950,00	1	006820150

710

chiavi a bussola Macchina serie normale



UNI/ISO 2725 DIN 3129

Ø mm	Ø mm	L mm	Ø1 mm	€	Icon	Icon
7	12,5	28	19	7,20	3	007100007
8	13,8	28	19	7,20	3	007100008
9	15,0	28	19	7,20	3	007100009
10	16,3	28	19	7,20	3	007100010
11	17,5	30	19	7,20	3	007100011
12	19,0	30	19	7,20	3	007100012
13	20,0	30	22	7,60	3	007100013
14	21,3	30	22	7,60	3	007100014
16	23,8	30	22	7,70	3	007100016
17	25,0	30	22	7,70	3	007100017
18	26,3	30	22	7,90	3	007100018
19	27,5	30	22	7,90	3	007100019
21	30,0	32	22	8,70	3	007100021
22	32,0	32	22	9,60	3	007100022

710/C10

10 chiavi a bussola Macchina



710/C10	€ 96,50	Icon	1	007100910
7-8-10-11-12-13 14-17-19-22 mm				

Icon 130x55x40 mm - Icon 800 g

710/16

raccordo Macchina con attacco quadro femmina 3/8" e maschio 1/2"



L mm	Ø mm	Icon	Icon	€	Icon	Icon
32	22	3/8"	1/2"	19,50	3	007100810

710/20

prolunga Macchina con attacchi quadri maschio e femmina 3/8"



L mm	Ø mm	€	Icon	Icon
75	22	19,90	2	007100821

710/21

prolunga Macchina con attacchi quadri maschio e femmina 3/8"



L mm	Ø mm	€	Icon	Icon
125	22	21,80	2	007100823

710/25

snodo Macchina con attacchi quadri maschio e femmina 3/8"



L mm	Ø mm	€	Icon	Icon
58	24	41,00	2	007100830

710/OR... - 710/SP...

anelli e spine per bussole e accessori Macchina



710/SP1	710/SP2	710/OR1	710/OR2	€	Icon	Icon
7-12	13-22	7-12	13-22	0,60	10	007100921
7-12	13-22	7-12	13-22	1,10	10	007100911
7-12	13-22	7-12	13-22	1,10	10	007100912

720

chiavi a bussola Macchina serie normale



UNI/ISO 2725 DIN 3129

Ø mm	Ø mm	L mm	Ø1 mm	€	Icon	Icon
8	15,0	38	25	8,80	5	007200008
9	16,0	38	25	8,80	5	007200009
10	17,0	38	25	8,90	5	007200010
11	18,5	38	25	8,90	5	007200011
12	20,0	38	25	8,90	5	007200012
13	21,0	38	25	8,90	5	007200013
14	22,5	38	25	8,90	5	007200014
15	23,0	38	30	10,00	5	007200015
16	25,0	38	30	10,00	5	007200016
17	26,0	38	30	10,00	5	007200017
18	27,5	38	30	10,00	5	007200018
19	28,5	38	30	10,00	5	007200019
21	31,0	38	30	11,00	5	007200021
22	32,5	38	30	11,20	5	007200022
23	34,0	38	30	12,20	5	007200023
24	35,0	38	30	12,20	5	007200024
27	38,5	45	30	14,30	3	007200027
30	42,0	50	30	15,50	3	007200030
32	44,0	50	30	17,80	3	007200032
36	50,0	50	30	25,50	3	007200036

720/C6

6 chiavi a bussola Macchina



720/C6	€ 83,00	Icon	1	007200910
13-14-17-19-22-24 mm				

Icon 195x80x55 mm - Icon 1100 g

720/C12

12 chiavi a bussola Macchina



720/C12	€ 157,50	Icon	1	007200912
10-11-12-13-14-17 19-22-24-27-30-32 mm				

Icon 195x80x55 mm - Icon 2000 g

720MC

chiavi a bussola Macchina serie normale colorate



Ø mm	Ø mm	L mm	€	Icon	Icon
10	17,0	38	9,30	3	007202010
11	18,5	38	9,30	3	007202011
12	20,0	38	9,30	3	007202012
13	21,0	38	9,30	3	007202013
14	22,5	38	9,30	3	007202014
15	23,0	38	10,50	3	007202015
16	25,0	38	10,50	3	007202016
17	26,0	38	10,50	3	007202017
18	27,5	38	10,50	3	007202018
19	28,5	38	10,50	3	007202019
21	31,0	38	11,60	2	007202021
22	32,5	38	11,60	2	007202022
24	35,0	38	12,70	2	007202024

720MC/C13

12 chiavi a bussola Macchina colorate

12"



720MC/C13 € 165,00 1 007202913
10-11-12-13-14-15
16-17-18-19-21-22
24 mm

335x145x60 mm - 2,4 kg

720AS

chiavi a bussola Macchina serie normale

12"



"	Ø mm	L mm	Ø1 mm	€		
3/8	17,0	38	25	14,50	2	007200210
7/16	18,2	38	25	14,50	2	007200211
1/2	20,7	38	25	14,50	2	007200213
9/16	22,0	38	25	14,50	2	007200214
5/8	24,5	38	30	15,50	2	007200216
11/16	25,7	38	30	15,50	2	007200217
3/4	28,2	38	30	15,50	2	007200219
13/16	30,7	38	30	16,50	2	007200221
7/8	32,0	38	30	16,50	2	007200222
15/16	34,5	38	30	17,50	2	007200224
1	35,7	38	30	19,00	2	007200225
1.1/16	38,2	40	30	21,00	1	007200227
1.1/8	40,7	42	30	23,50	1	007200229
1.1/4	44,5	42	30	26,00	1	007200232

720S

chiavi a bussola Macchina serie compatta

12"



mm	Ø mm	L mm	Ø1 mm	€		
13	20,0	28,0	23,8	5,60	3	007200113
15	23,0	28,0	23,8	5,60	3	007200115
17	25,8	28,0	25,8	6,10	3	007200117
19	27,8	28,0	27,8	6,70	3	007200119
22	31,8	28,0	30,0	7,30	3	007200122
24	33,8	28,0	30,0	7,90	3	007200124

12"



720S/SB6 € 46,50 1 007200906
13-15-17-19-22-24 mm

720L

chiavi a bussola Macchina serie lunga

12"



UNI/ISO 2725

mm	Ø mm	L mm	Ø1 mm	€		
10	17,0	80	25	15,30	2	007200310
11	18,5	80	25	15,30	2	007200311
12	20,0	80	25	15,30	2	007200312
13	21,0	80	25	15,30	2	007200313
14	22,5	80	25	15,30	2	007200314
15	23,0	80	30	17,40	2	007200315
16	25,0	80	30	17,40	2	007200316
17	26,0	80	30	17,40	2	007200317
18	27,5	80	30	18,50	2	007200318
19	28,5	80	30	18,50	2	007200319
21	31,0	80	30	19,50	2	007200321
22	32,5	80	30	19,50	2	007200322
24	35,0	80	30	20,50	2	007200324
27	38,5	80	30	25,50	2	007200327
30	42,0	80	30	31,50	2	007200330
32	44,0	80	30	31,50	2	007200332
36	50,0	80	30	40,00	2	007200336

720L/S3

serie di 3 chiavi a bussola 720L

12"



17-19-21 mm € 55,50 1 007200355

720LS

chiavi a bussola Macchina serie lunga sottile

12"



UNI/ISO 2725

mm	Ø mm	L mm	Ø1 mm	€		
10	15,5	78	24	16,50	2	007200360
11	16,7	78	24	16,50	2	007200361
12	18,0	78	24	16,50	2	007200362
13	19,2	78	24	16,50	2	007200363
14	20,5	78	24	16,50	2	007200364
15	21,7	78	24	17,00	2	007200365
16	23,0	78	24	17,00	2	007200366
17	24,2	78	29	19,00	2	007200367
18	25,5	78	29	20,50	2	007200368
19	26,7	78	29	20,50	2	007200369
21	29,2	78	29	21,50	2	007200371
22	30,5	78	29	21,50	2	007200372
24	33,0	78	29	22,00	2	007200374
27	36,7	78	29	27,00	2	007200377
30	40,5	78	29	34,00	2	007200380
32	43,0	78	29	35,00	2	007200382
36	48,0	78	29	53,00	2	007200386

720LC

chiavi a bussola Macchina per dadi ruote con inserti polimerici colorati

12"



mm	Ø mm	€		
17	26,5	11,00	2	007200637
19	28,5	11,00	2	007200639
21	30,3	11,50	2	007200641
22	32,4	11,90	2	007200642
24	34,6	13,00	2	007200644

12"



720LC/C3 € 33,50 1 007200653
17-19-21 mm
148x132x44 mm - 860 g

12"



720LC/S5 € 58,50 1 007200645
17-19-21-22-24 mm

720IC

inserti di ricambio polimerici colorati per chiavi a bussola 720LC-720LCL



720IC	mm	€		
17	17	4,50	1	007200687
19	19	4,50	1	007200689
21	21	4,50	1	007200691
22	22	4,50	1	007200692
24	24	4,50	1	007200694

720LCL

chiavi a bussola Macchina per dadi ruote con inserti polimerici colorati serie lunga



mm	∅ mm	€	1	007200737
17	26,5	18,30	1	007200737
19	28,5	18,30	1	007200739
21	30,3	18,30	1	007200741



720LCL/C3	€	1	007200753
17-19-21 mm	70,00	1	007200753

210x50x150 mm - 1,65 kg

720MRC

chiave a bussola Macchina con inserto polimerico per vite ruota con profilo Mercedes



mm	∅ mm	L mm	1/2"	€	1	007200631
17	27	85	1/2"	17,00	1	007200631

720TC

barre di torsione Macchina colorate per dadi ruote autoveicoli con attacchi quadri maschio e femmina 1/2"



Nm	L mm	€	1	007200769
90	200	18,00	1	007200769
100	200	18,00	1	007200770
110	200	18,00	1	007200771
120	200	18,00	1	007200772
135	200	18,00	1	007200773

12"



720TC/S5	€	1	007200779
90-100-110-120-135 Nm	90,00	1	007200779

260x50x175 mm - 1,35 kg

720FTX

chiavi a bussola Macchina per viti con testa a profilo Torx®



∅ mm	L mm	Ø1 mm	€	2	007200410
E10	14,0	38	25	14,40	2 007200410
E12	15,9	38	25	14,40	2 007200412
E14	17,7	38	25	14,40	2 007200414
E16	20,0	38	25	14,40	2 007200416
E18	22,0	38	25	14,40	2 007200418
E20	25,0	40	25	15,20	2 007200420
E24	30,0	40	30	15,20	2 007200424



720FTX/SB6	€	1	007200450
E10-E12-E14 E16-E18-E20	94,50	1	007200450

720TX

chiavi a bussola maschio Macchina per viti con impronta Torx®



∅ mm	L mm	L1 mm	€	3	007200460
T30	25	78	54	12,50	3 007200460
T40	25	78	54	12,50	3 007200470
T45	25	78	54	12,80	3 007200472
T50	25	78	54	12,80	3 007200474
T55	25	78	54	14,50	3 007200476
T60	25	78	54	15,50	3 007200478



Beta

720TX/C6

6 chiavi a bussola maschio Macchina per viti con impronta Torx®



720TX/C6	€	1	007200483
T30-T40-T45 T50-T55-T60	107,50	1	007200483

275x120x65 mm - 5700 g

720ME

chiavi a bussola Macchina maschio esagonale



mm	∅ mm	L mm	L1 mm	€	3	007200505
5	25	78	54	12,00	3	007200505
6	25	78	54	12,00	3	007200506
8	25	78	54	12,00	3	007200508
10	25	78	54	12,00	3	007200510
12	25	78	54	12,00	3	007200512
14	25	78	54	13,50	3	007200514
17	25	78	54	13,50	3	007200517
19	25	78	54	13,50	3	007200519

720ME/C8

8 chiavi a bussola Macchina maschio esagonale



720ME/C8	€	1	007200525
5-6-8-10-12 14-17-19 mm	125,50	1	007200525

270x120x45 mm - 1710 g

720/15

raccordo Macchina con attacco quadro femmina 1/2" e maschio 3/8"

12"



L mm 37,5
Ø mm 25
1/2 3/8
€ 10,00
3 007200810



E' assolutamente necessario commisurare la coppia di serraggio alla capacità del quadro maschio per evitare rotture o danni accidentali

720/16

raccordo Macchina con attacco quadro femmina 1/2" e maschio 3/4"

12"



L mm 44
Ø mm 30
1/2 3/4
€ 17,30
3 007200814

720/20

prolunga Macchina con attacchi quadri maschio e femmina 1/2"

12"



L mm 75
Ø mm 25
€ 17,80
3 007200818

720/21

prolunga Macchina con attacchi quadri maschio e femmina 1/2"

12"



L mm 125
Ø mm 25
€ 19,30
3 007200822

720/25

snodo Macchina con attacchi quadri maschio e femmina 1/2"

12"



L mm 64
Ø mm 28
€ 33,00
2 007200831

720/OR... - 720/SP...

anelli e spine per bussole e accessori Macchina

12"

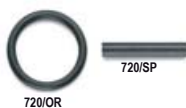

	720 mm	720TX T30+T60	€		
720/OR1	10+14		1,15	10	007200923
720/OR2	15+32		1,15	10	007200924
720/SP1	10+14	T30+T60	1,70	10	007200913
720/SP2	15+32		1,70	10	007200914

727PI/16

bussola portainseri Macchina per 727/ES16 e 727/ES16TX

3/4"



Ø mm 44
L mm 52
mm 16
3/4
€ 39,00
2 007270016

727/ES16

inserti Macchina maschio esagonale, attacco 16 mm

Ø



mm	mm	L mm	€		
10	16	40	13,20	2	007270110
12	16	40	13,20	2	007270112
13	16	40	13,20	2	007270113
14	16	40	13,20	2	007270114
16	16	40	14,20	2	007270116
17	16	40	14,20	2	007270117
18	16	40	14,80	2	007270118
19	16	40	14,80	2	007270119
22	16	40	17,00	2	007270122

727/ES16TX

inserti Macchina maschio per viti con impronta Torx®, attacco 16 mm

Ø



Ø mm	mm	L mm	€		
T55	16	50	19,80	2	007270355
T60	16	50	19,80	2	007270360
T70	16	50	19,80	2	007270370

727PI/22

bussola portainseri Macchina per 727/ES22 e 727/ES22TX

1"



Ø mm 54
L mm 70
mm 22
€ 60,50
2 007270022

727/ES22

inserti Macchina maschio esagonale, attacco 22 mm

Ø



mm	mm	L mm	€		
19	22	50	17,00	2	007270219
22	22	50	17,00	2	007270222
24	22	50	18,80	2	007270224
27	22	50	21,00	2	007270227
30	22	50	25,00	2	007270230
32	22	50	27,50	2	007270232

727/ES22TX

inserti Macchina maschio per viti con impronta Torx®, attacco 22 mm

Ø



Ø mm	mm	L mm	€		
T80	22	60	28,00	2	007270480
T90	22	60	28,00	2	007270490
T100	22	60	28,00	2	007270500

727/C16

12 inserti Macchina maschio e 4 accessori

Ø

Ø

3/4"



1"

727/C16 € 377,00 1 007270900

727PI/16

727/ES16 14-17-19 mm

727/ES16TX T55-T60-T70

727PI/22

727/ES22 22-24-27 mm

727/ES22TX T80-T90-T100

96BPC 3-4 mm

335x145x60 mm - 3,6 kg

727PI/32

bussola portainseri Macchina
per 727/ES32



Ø mm	L mm	Ø mm	€	Icon	Code
86	66	32	150,00	1	007270032

727/ES32

inserti Macchina maschio esagonale,
attacco 32 mm



mm	Ø mm	L mm	€	Icon	Code
19	32	44	38,50	2	007270519
22	32	44	38,50	2	007270522
24	32	44	38,50	2	007270524
27	32	44	38,50	2	007270527
30	32	44	38,50	2	007270530
32	32	44	38,50	2	007270532
36	32	44	43,50	2	007270536

728

chiavi a bussola Macchina
serie normale



UNI/ISO 2725 DIN 3129

Ø mm	L mm	Ø1 mm	€	Icon	Code
17	30,0	51	44	21,80	2 007280017
18	31,0	51	44	21,80	2 007280018
19	32,5	51	44	21,80	2 007280019
21	35,0	51	44	21,80	2 007280021
22	36,0	51	44	21,80	2 007280022
23	37,5	51	44	22,30	2 007280023
24	38,5	51	44	22,30	2 007280024
27	42,5	53	44	22,30	2 007280027
28	44,0	53	44	23,10	2 007280028
30	46,0	53	44	23,50	2 007280030
32	48,5	57	44	24,50	2 007280032
33	50,0	57	44	26,50	2 007280033
34	51,0	57	44	26,50	2 007280034
35	52,5	57	44	27,00	2 007280035
36	53,5	57	44	28,00	2 007280036
38	56,0	57	44	31,50	1 007280038
40	58,5	58	44	33,50	1 007280040
41	60,0	58	44	34,00	1 007280041
44	64,0	62	44	37,00	1 007280044
45	65,0	62	44	39,50	1 007280045
46	66,0	62	44	40,00	1 007280046
50	71,0	68	54	47,50	1 007280050
55	77,5	71	54	52,00	1 007280055
60	83,0	73	54	59,50	1 007280060
65	88,0	78	54	66,50	1 007280065

728/C10

10 chiavi a bussola Macchina



728/C10	€	Icon	Code
17-19-22-24-27-30 32-36-41-46 mm	286,00	1	007280910

275x120x65 mm - 5,7 kg

728AS

chiavi a bussola Macchina
serie normale



Ø mm	L mm	Ø1 mm	€	Icon	Code
3/4	32,0	51	41	22,00	1 007280219
13/16	35,0	51	41	22,50	1 007280221
7/8	36,0	51	41	22,50	1 007280222
15/16	38,5	51	41	22,50	1 007280224
1	40,0	53	41	23,00	1 007280225
1.1/16	42,5	53	44	24,00	1 007280227
1.1/8	44,0	53	44	24,50	1 007280230
1.1/4	48,5	57	44	25,00	1 007280232
1.5/16	50,0	57	44	26,50	1 007280233
1.7/16	53,5	57	44	28,00	1 007280236
1.1/2	56,0	57	44	31,00	1 007280238
1.5/8	60,0	58	44	34,00	1 007280241

728FTX

chiavi a bussola Macchina
per viti con testa a profilo Torx®



Ø mm	L mm	Ø1 mm	€	Icon	Code
E20	28,5	50	44	29,50	2 007280420
E22	30,0	50	44	29,50	2 007280422
E24	32,5	50	44	29,50	2 007280424

728L

chiavi a bussola Macchina
serie lunga



Ø mm	L mm	Ø1 mm	€	Icon	Code
19	32,5	90	44	34,50	2 007280319
21	35,0	90	44	34,50	2 007280321
22	36,0	90	44	34,50	2 007280322
24	38,5	90	44	34,50	2 007280324
26	41,0	90	44	34,50	2 007280326
27	42,5	90	44	34,50	2 007280327
30	46,0	90	44	36,00	2 007280330
32	48,5	90	44	38,00	2 007280332

Ø mm	Ø mm	L mm	Ø1 mm	€	Icon	Code
33	50,0	90	44	40,50	1	007280333
34	51,0	90	44	43,00	1	007280334
36	53,5	90	44	45,00	1	007280336
38	56,0	90	44	51,50	1	007280338
41	60,0	90	44	53,00	1	007280341
44	64,0	90	44	61,00	1	007280344
46	66,0	90	44	61,00	1	007280346
50	71,0	90	44	73,00	1	007280350
55	77,5	100	54	96,00	1	007280355



728L/S3	€	Icon	Code
30-32-36 mm	119,00	1	007280393

728LS

chiavi a bussola Macchina
serie lunga sottile



Ø mm	L mm	Ø1 mm	€	Icon	Code
17	28,0	100	43	39,00	2 007280517
19	30,5	100	43	39,00	2 007280519
22	34,3	100	43	40,00	2 007280522
24	36,8	100	43	40,00	2 007280524
27	40,5	100	43	40,00	2 007280527
30	44,3	100	43	40,00	2 007280530
32	46,8	100	43	43,00	2 007280532
33	48,0	100	43	44,50	2 007280533
36	51,8	100	43	51,00	1 007280536

728LQ

chiavi a bussola Macchina
serie lunga
(per dadi ruote ISUZU)



Ø mm	L mm	Ø mm	Ø1 mm	€	Icon	Code
19	90	35	43,5	35,00	1	007280619
21	90	42	43,5	35,00	1	007280621

728/15

raccordo Macchina con attacco quadro
femmina 3/4" e maschio 1/2"



L mm	Ø mm	Icon	Icon	€	Icon	Code
58	38	3/4	1/2	27,00	2	007280810



E' assolutamente necessario commisurare la coppia di serraggio alla capacità del quadro maschio per evitare rotture o danni accidentali

728/16

raccordo Macchina con attacco quadro femmina 3/4" e maschio 1"



728/21

prolunga Macchina con attacchi quadri maschio e femmina 3/4"



728/22

prolunga Macchina con attacchi quadri maschio e femmina 3/4"



728/22L

prolunga Macchina con attacchi quadri maschio e femmina 3/4"



728/25

snodo Macchina con attacchi quadri maschio e femmina 3/4"



728/OR - 728/SP

anelli e spine per bussola e accessori Macchina

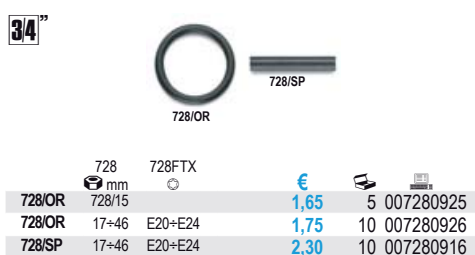

729

chiavi a bussola Macchina serie normale



UNI/ISO 2725 DIN 3129

Ø	Ø1	L	Price	Part number
24	41,5	58	35,00	007290024
27	45,0	60	35,00	007290027
30	49,0	62	35,00	007290030
32	51,5	63	36,00	007290032
33	52,5	63	36,00	007290033
34	54,0	63	36,00	007290034
36	56,5	66	36,00	007290036
38	59,0	66	43,50	007290038
41	62,5	68	44,50	007290041
46	69,0	72	49,50	007290046
50	74,0	76	61,00	007290050
55	80,0	84	65,00	007290055
60	86,5	88	79,00	007290060
65	92,5	92	90,00	007290065
70	99,0	96	115,00	007290070
75	105,0	102	135,00	007290075
80	111,5	102	145,00	007290080

729L

chiavi a bussola Macchina serie lunga



Ø	Ø1	L	Price	Part number
24	41,5	108	62,00	007290324
27	45,0	108	62,00	007290327
30	49,0	108	62,00	007290330
32	51,5	108	62,00	007290332
33	52,2	108	63,00	007290333
34	54,0	108	63,00	007290334
36	56,5	108	63,00	007290336
41	62,5	108	75,00	007290341
46	69,0	108	87,00	007290346
50	74,0	108	97,00	007290350
55	80,0	108	116,00	007290355
60	86,5	108	126,00	007290360
65	92,5	108	152,00	007290365
70	99,0	108	173,00	007290370
75	105,0	108	195,00	007290375
80	111,5	108	205,00	007290380

729LS

chiavi a bussola Macchina serie lunga sottile



Ø	Ø1	L	Price	Part number
22	36,0	108	62,00	007290522
24	38,5	108	62,00	007290524
27	46,0	108	62,00	007290527
30	50,0	108	66,00	007290530
32	50,0	108	66,00	007290532
33	52,0	108	66,00	007290533
36	56,0	108	66,00	007290536

729T

barre di torsione Macchina per dadi ruote



Ø	Nm	L	Price	Part number
24	350	300	115,00	007290724
27	450	300	115,00	007290757
30	500	300	116,00	007290730
32	450	300	118,00	007290732
32	600	300	118,00	007290762
33	600	300	124,00	007290763
36	600	300	131,00	007290736

729/15

raccordo Macchina con attacco quadro femmina 1" e maschio 3/4"



! E' assolutamente necessario commisurare la coppia di serraggio alla capacità del quadro maschio per evitare rotture o danni accidentali

729/16

raccordo Macchina con attacco quadro femmina 1" e maschio 1.1/2"



729/21

prolunga Macchina con attacchi quadri maschio e femmina 1"



729/22

prolunga Macchina con attacchi quadri maschio e femmina 1"



729/25

snodo Macchina con attacchi quadri maschio e femmina 1"



L mm	Ø mm	€	Icon	Code
130	54	135,00	1	007290830

729/OR... - 729/SP...

anelli e spine per bussole e accessori Macchina



Code	Ø mm	L mm	€	Icon	Code
729/OR1	50+60	24+70	1,80	5	007290927
729/OR2	75+125	24+70	2,80	5	007290928
729/SP1	50+60	24+70	1,70	5	007290917
729/SP2	75+125	24+70	2,80	5	007290918

730

chiavi a bussola Macchina serie normale



UNI/ISO 2725 DIN 3129

Ø mm	Ø mm	L mm	Ø1 mm	€	Icon	Code
50	81	87	84	185,00	1	007300050
55	88	90	86	190,00	1	007300055
60	94	95	86	210,00	1	007300060
65	100	100	86	230,00	1	007300065
70	106	105	86	273,00	1	007300070
75	113	110	86	315,00	1	007300075
80	119	115	86	360,00	1	007300080
85	125	120	86	400,00	1	007300085
90	132	125	86	455,00	1	007300090
95	138	125	96	530,00	1	007300095
100	144	130	96	615,00	1	007300100
105	150	135	96	685,00	1	007300105
110	157	140	96	745,00	1	007300110
115	163	140	96	800,00	1	007300115
120	169	145	96	895,00	1	007300120
125	175	145	96	935,00	1	007300125

730/15

raccordo Macchina riduttore



L mm	Ø mm	Icon	Code
105	84,0	1 1/2	145,00 1 007300810



E' assolutamente necessario commisurare la coppia di serraggio alla capacità del quadro maschio per evitare rotture o danni accidentali

733/15

raccordo Macchina riduttore



L mm	Ø mm	Icon	Code
156	127	2 1/2	510,00 1 007330810

851

portainseri magnetico con impugnatura



L1 mm	L mm	€	Icon	Code
45	165	13,20	2	008510165
125	245	15,30	2	008510245

851SR

portainseri a sgancio rapido con impugnatura



L mm	L1 mm	€	Icon	Code
230	110	18,30	2	008510001

852

portainseri a T snodato

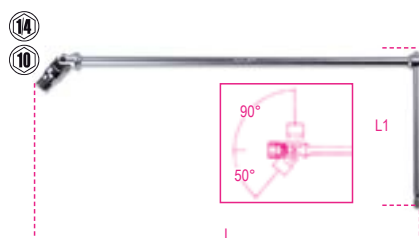

Icon	L mm	L1 mm	€	Icon	Code
1/4"	400	160	36,00	2	008520006
10 mm	400	160	36,00	2	008520010

855P

Giravite portainseri a cricchetto reversibile con impugnatura snodata 7 inserti integrati

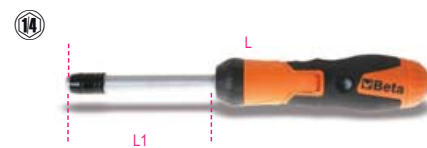

L mm	L1 mm	€	Icon	Code
240	100	60,50	1	008550010

- 860PH PH1 - PH2
- 860PZ PZ1 - PZ2
- 860LP LP 0,8x5,5 mm
- 860PE 4 - 5 mm

860LP

inserti colorati per avvitatori per viti a testa con intaglio



ISO 2351-1
ISO 1173 C 6,3

SxA mm	L mm	€	Icon	Code
0,5x3	25	1,58	5	008600005
0,6x4,5	25	1,58	5	008600010
0,8x5,5	25	1,58	5	008600015
1x5,5	25	1,58	5	008600020
1,2x6,5	25	1,58	5	008600025

860PH

inserti colorati per avvitatori per viti con impronta a croce Phillips®



ISO 2351-2
ISO 1173 C 6,3

PH	L mm	€	Icon	Code
0	25	1,58	5	008600220
1	25	1,58	5	008600225
2	25	1,58	5	008600230
3	25	1,58	5	008600245
4	25	2,28	5	008600250

Beta

860PZ

inserti colorati per avvitatori
per viti con impronta a croce
Pozi driv® - Supadriv®



ISO 2351-2
ISO 1173 C 6,3

PZ	L mm	€	5	10
1	25	1,58	5	008600320
2	25	1,58	5	008600325
3	25	1,58	5	008600330
4	25	2,28	5	008600335

860PE

inserti colorati maschio esagonale
per avvitatori



ISO 2351-3
ISO 1173 C 6,3

mm	L mm	€	5	10
2	25	1,68	5	008600101
2,5	25	1,68	5	008600102
3	25	1,68	5	008600103
4	25	1,68	5	008600104
5	25	1,68	5	008600105
6	25	1,68	5	008600106
8	25	2,10	5	008600108
10	25	2,10	5	008600110

860TX

inserti colorati per avvitatori
per viti con impronta Torx®

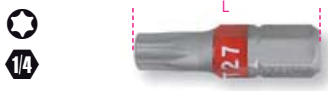

ISO 1173 C 6,3

	L mm	€	5	10
T6	25	2,10	5	008600704
T7	25	2,10	5	008600705
T8	25	2,10	5	008600710
T9	25	2,10	5	008600715
T10	25	1,68	5	008600720
T15	25	1,68	5	008600725
T20	25	1,68	5	008600730
T25	25	1,68	5	008600735
T27	25	1,68	5	008600740
T30	25	1,68	5	008600745
T40	25	1,68	5	008600750

860RTX

inserti colorati per avvitatori
per viti con impronta Tamper Resistant Torx®



ISO 1173 C 6,3

	L mm	€	5	10
T9	25	2,28	5	008600550
T10	25	2,28	5	008600555
T15	25	2,28	5	008600560
T20	25	2,28	5	008600565
T25	25	2,28	5	008600570
T27	25	2,28	5	008600575
T30	25	2,28	5	008600580
T40	25	2,28	5	008600585

860/55

cricchetto reversibile portainseri



L mm	Ø	€	5	10
100	1/4	27,00	3	008600870

860/58

cricchetto portainseri con impugnatura rotante

- L'inserto si può inserire su entrambi i lati per avvitare o svitare
- Impugnatura bimeriale



L mm	Ø	A mm	€	5	10		
860/58	126	1/4"	27	15	62,00	1	008600884

860/C27

25 inserti per avvitatori, 1 raccordo
e 1 cricchetto reversibile in astuccio tascabile



860/C27	€	5	10
	73,00	1	008600880

860/55	100 mm	
860LP	0,5x3-1,0x5,5-1,2x6,5 mm	
860PH	PH1-PH2(x2)-PH3	
860PZ	PZ1-PZ2(x2)-PZ3	
860PE	2-2,5-3-4-5-6 mm	
860TX	T6-T8-T10-T15-T20-T25-T30-T40	
892/0	● 1/4 ■ 1/4	

860PHZ/A10

10 inserti con portainseri magnetico in
astuccio tascabile



860PHZ/A10	€	5	10
	30,50	1	008600910

860PH	PH1	1	n.
	PH2	3	
	PH3	1	
860PZ	PZ1	1	
	PZ2	3	
	PZ3	1	
882M1	○ 1/4 ● 1/4		

860PE/A10

10 inserti con portainseri magnetico in
astuccio tascabile



860PE/A10	€	5	10
	31,50	1	008600920

860PE	2 - 2,5 mm	1	n.
	3 - 4 - 5 - 6 mm	2	
882M1	○ 1/4 ● 1/4		

860TX/A10

10 inserti con portainseri magnetico in astuccio tascabile



860TX/A10 € 32,50 1 008600970

860TX	T7 - T8 - T9 - T10 - T15 - T20	1
882M1	T25 - T27 - T30 - T40	1
	○ 1/4 ● 1/4	

860MIX/A10

10 inserti con portainseri magnetico in astuccio tascabile



860MIX/A10 € 30,50 1 008600900

860LP	0,5x3 - 1x5,5 - 1,2x6,5 mm	1
860PH	PH1	1
	PH2	2
	PH3	1
860PZ	PZ1 - PZ2 - PZ3	1
882M1	○ 1/4 ● 1/4	

860MIX/A31

30 inserti con portainseri magnetico a sgancio rapido in astuccio tascabile



860MIX/A31 € 71,50 1 008600902

860LP	0,5x3 - 0,6x4,5 - 0,8x5,5 1,0x5,5 - 1,2x6,5 mm
860PE	2 - 2,5 - 3 - 4 - 5 - 6 8 - 10 mm
860PH	PH0 - PH1 - PH2 - PH3 - PH4
860PZ	PZ1 - PZ2 - PZ3 - PZ4
860RTX	T9 - T10 - T15 - T20 T25 - T27 - T30 - T40
882MSR 50	○ 1/4 ● 1/4

860/C38P

1 portainseri con impugnatura a criccheto reversibile, 27 inserti per avvitatori, 8 bussole esagonali e 2 accessori



860/C38P € 158,50 1 008600878

860LP	0,6x4,5 - 0,8x5,5 - 1,0x5,5 - 1,2x6,5 mm
860PE	2-2,5-3-4(x2)-5(x2)
860PH	PH1(x2)-PH2(x2)-PH3
860PZ	PZ1(x2)-PZ2(x2)-PZ3
860TX	T10-T15-T20-T25-T30-T40
900	5-5,5-6-7-8-9-10-13 mm
892/0	● 1/4 ■ 1/4
892/3	● 1/4 ■ 1/4
855P	240 mm

270x120x45 mm

861LP

inserti per avvitatori per viti a testa con intaglio



ISO 2351-1

ISO 1173 C 6,3

SxA mm	L mm	€	10	100
0,5x3	25	1,02	10	008610005
0,6x4	25	1,02	10	008610007
0,6x4,5	25	1,02	10	008610010
0,8x5,5	25	1,02	10	008610015
1x5,5	25	1,02	10	008610020
1,2x6,5	25	1,02	10	008610025
1,2x8	25	1,95	10	008610028
1,6x8	25	1,95	10	008610030

861PH

inserti per avvitatori per viti con impronta a croce Phillips®



ISO 2351-2

ISO 1173 C 6,3

PH	L mm	€	10	100
0	25	1,00	10	008610200
1	25	1,00	10	008610205
2	25	1,00	10	008610210
2L	50	1,95	10	008610213
3	25	1,00	10	008610215
4	25	2,70	10	008610220

861PH/C

inserti per avvitatori per viti con impronta a croce Phillips®



ISO 2351-2

ISO 1173 C 6,3

PH	L mm	€	200	1000
0	25	0,77	200	008610250
1	25	0,77	200	008610255
2	25	0,77	200	008610260
2L	50	1,48	100	008610263
3	25	0,77	200	008610265
4	25	1,98	100	008610270

861PZ

inserti per avvitatori per viti con impronta a croce Pozidriv® - Supadriv®



ISO 2351-2

ISO 1173 C 6,3

PZ	L mm	€	10	100
1	25	1,00	10	008610300
2	25	1,00	10	008610305
2L	50	1,93	10	008610308
3	25	1,00	10	008610310
4	25	2,68	10	008610315



861PZ/C

inserti per avvitatori
per viti con impronta a croce
Pozi driv® - Supadriv®



ISO 2351-2
ISO 1173 C 6,3

PZ	L mm	€	🔧	📦
1	25	0,77	200	008610350
2	25	0,77	200	008610355
2L	50	1,48	100	008610358
3	25	0,77	200	008610360
4	25	1,95	100	008610365

861PE

inserti maschio esagonale
per avvitatori



ISO 2351-3

ISO 1173 C 6,3

mm	L mm	€	🔧	📦
2	25	1,08	10	008610100
2,5	25	1,08	10	008610105
3	25	1,08	10	008610110
4	25	1,08	10	008610115
5	25	1,08	10	008610120
6	25	1,08	10	008610125
8	25	1,63	10	008610130
10	25	2,15	10	008610135

861TX

inserti per avvitatori
per viti con impronta Torx®



ISO 1173 C 6,3

T	L mm	€	🔧	📦
T5	25	1,43	10	008610399
T6	25	1,43	10	008610400
T7	25	1,43	10	008610405
T8	25	1,43	10	008610410
T9	25	1,43	10	008610415
T10	25	1,13	10	008610420
T15	25	1,13	10	008610425
T20	25	1,13	10	008610430
T25	25	1,13	10	008610435
T27	25	1,13	10	008610440
T30	25	1,13	10	008610445
T40	25	1,13	10	008610450

861TX/C

inserti per avvitatori
per viti con impronta Torx®

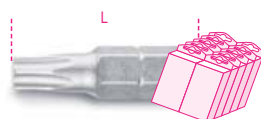

ISO 1173 C 6,3

T	L mm	€	🔧	📦
T10	25	0,87	200	008610470
T15	25	0,87	200	008610475
T20	25	0,87	200	008610480
T25	25	0,87	200	008610485
T27	25	0,87	200	008610490
T30	25	0,87	200	008610495
T40	25	0,87	200	008610499

861RTX

inserti per avvitatori per viti
con impronta Tamper Resistant Torx®



ISO 1173 C 6,3

T	L mm	€	🔧	📦
T6	25	2,10	10	008610537
T7	25	2,10	10	008610538
T8	25	2,10	10	008610540
T9	25	2,10	10	008610500
T10	25	2,10	10	008610505
T15	25	2,10	10	008610510
T20	25	2,10	10	008610515
T25	25	2,10	10	008610520
T27	25	2,10	10	008610525
T30	25	2,10	10	008610530
T40	25	2,10	10	008610535
T45	25	4,05	10	008610539

861RIBE

inserti per avvitatori
per viti con impronta RIBE®



ISO 1173 C 6,3

M	L mm	€	🔧	📦
M5	25	0,92	10	008610705
M6	25	0,92	10	008610706
M7	25	1,13	10	008610707
M8	25	1,13	10	008610708
M9	25	1,63	10	008610709

861TRW

inserti per avvitatori
per viti con impronta Tri-Wing®



ISO 1173 C 6,3

GR	L mm	€	🔧	📦
1	25	1,78	10	008610601
2	25	1,78	10	008610602
3	25	1,78	10	008610603
4	25	1,78	10	008610604
5	25	1,78	10	008610605
6	25	2,60	10	008610606

861TQS

inserti per avvitatori
per viti con impronta Torq-Set®



ISO 1173 C 6,3

GR	L mm	€	🔧	📦
0	25	1,78	10	008610620
1	25	1,78	10	008610621
2	25	1,78	10	008610622
3	25	1,78	10	008610623
4	25	1,78	10	008610624
5	25	1,78	10	008610625
6	25	1,78	10	008610626
8	25	1,78	10	008610628
10	25	1,78	10	008610630

861SP

inserti per avvitatori per viti con impronta
Spanner



ISO 1173 C 6,3

SP	D mm	L mm	€	🔧	📦
4	1,5	25	1,48	10	008610650
6	2,4	25	1,48	10	008610653
8	2,8	25	1,48	10	008610656
10	3,3	25	1,48	10	008610658
12	3,9	25	1,48	10	008610660

1483KV-PT/S7



1483KV PT/S7

177

861XZN

inserti per avvitatori
per viti con impronta XZN®



ISO 1173 C 6,3

M	L mm	€	🔧	📦
M5	25	0,92	10	008610725
M6	25	0,92	10	008610726
M8	25	1,18	10	008610728



861/C61P

61 inserti per avvitatori e 1 portainseriti magnetico a sgancio rapido

1/4"



861/C61P € 135,00 1 008610978

- 861LP 0,5x3 - 0,6x4,5 - 0,8x5,5 - 1,0x5,5 - 1,2x6,5 - 1,2x8 - 1,6x8 mm
- 861PE 2 - 2,5 - 3 - 4 - 5 - 6 - 8 - 10 mm
- 861PH PH0 - PH1 - PH2 - PH3
- 861PZ PZ1 - PZ2 - PZ3
- 861TX T6 - T7 - T8 - T9 - T10 - T15 - T20 - T25 - T27 - T30 - T40
- 861RTX T9 - T10 - T15 - T20 - T25 - T27 - T30 - T40
- 861TRW 1 - 2 - 3 - 4 - 5 - 6
- 861TQS 0 - 1 - 2 - 3 - 4 - 5 - 6 - 8 - 10
- 861SP 4 - 6 - 8 - 10 - 12
- 851SR \varnothing 1/4"

270x120x45 mm - 975 g

862LP

inserti per avvitatori per viti a testa con intaglio

1/4"



ISO 2351-1

ISO 1173 E 6,3

SxA mm	L mm	€	5	008620005
0,5x3	50	2,95	5	008620005
0,6x4,5	50	2,95	5	008620010
0,8x5,5	50	2,95	5	008620015
1x5,5	50	2,95	5	008620020
1,2x6,5	50	2,95	5	008620025
1,2x8	50	3,65	5	008620030
1,6x8	50	3,65	5	008620035

862PH

inserti per avvitatori per viti con impronta a croce Phillips®

1/4"



ISO 2351-2

ISO 1173 E 6,3

PH	L mm	€	5	008620200
1	50	2,95	5	008620200
2	50	2,95	5	008620205
3	50	2,95	5	008620210

862PH/L

inserti per avvitatori per viti con impronta a croce Phillips®

1/4"



ISO 2351-2

ISO 1173 E 6,3

PH	L mm	€	5	008620230
1	70	5,40	5	008620230
2	70	5,40	5	008620232
3	70	5,40	5	008620234

862PH-XL

inserti per avvitatori per viti con impronta a croce Phillips®

1/4"



ISO 2351-2/ISO 1173 E 6,3

PH	L mm	€	5	008620250
1	100	5,55	5	008620250
2	100	5,55	5	008620252
3	100	5,55	5	008620254

862PZ

inserti per avvitatori per viti con impronta a croce Pozidriv® - Supadriv®

1/4"



ISO 2351-2

ISO 1173 E 6,3

PZ	L mm	€	5	008620300
1	50	3,05	5	008620300
2	50	3,05	5	008620305
3	50	3,05	5	008620310

862PE

inserti maschio esagonale per avvitatori

1/4"



ISO 2351-3

ISO 1173 E 6,3

mm	L mm	€	5	008620103
3	50	3,05	5	008620103
4	50	3,05	5	008620104
5	50	3,05	5	008620105
6	50	3,05	5	008620106
8	50	4,05	5	008620108

862TX

inserti per avvitatori per viti con impronta Torx®

1/4"



ISO 1173 E 6,3

T	L mm	€	5	008620506
T6	50	4,00	5	008620506
T7	50	4,00	5	008620507
T8	50	4,00	5	008620508
T9	50	4,00	5	008620509
T10	50	4,00	5	008620510
T15	50	4,00	5	008620515
T20	50	4,00	5	008620520
T25	50	4,00	5	008620525
T27	50	4,00	5	008620527
T30	50	4,00	5	008620530
T40	50	4,00	5	008620540

862TX/L

inserti per avvitatori per viti con impronta Torx®

1/4"



ISO 1173 E 6,3

T	L mm	€	5	008620556
T6	70	4,40	5	008620556
T7	70	4,40	5	008620557
T8	70	4,40	5	008620558
T9	70	4,40	5	008620559
T10	70	4,40	5	008620560
T15	70	4,40	5	008620565
T20	70	4,40	5	008620570
T25	70	4,40	5	008620575
T27	70	4,40	5	008620577
T30	70	4,40	5	008620580
T40	70	4,40	5	008620590

862TX-XL

inserti per avvitatori per viti con impronta Torx®

1/4"



ISO 1173 E 6,3

T	L mm	€	5	008620659
T9	100	4,75	5	008620659
T10	100	4,75	5	008620660
T15	100	4,75	5	008620665
T20	100	4,75	5	008620670
T25	100	4,75	5	008620675
T27	100	4,75	5	008620677
T30	100	4,75	5	008620680
T40	100	4,75	5	008620690

862F

inserti per avvitatori chiavi a bussola esagonale magnetici

1/4"



ISO 1173 E 6,3

mm	L mm	Ø mm	€	5	008620405
5,5	65	11	5,50	5	008620405
6	65	11	5,50	5	008620406
7	65	11	5,50	5	008620407
8	65	13	5,50	5	008620408
10	65	15	6,00	5	008620410
12	65	18	6,60	5	008620412
13	65	18	7,00	5	008620413

862F/A7

7 inserti per avvitatori chiavi a bussola esagonale magnetici, in astuccio tascabile



862F/A7 € 41,50 1 008620950

862F 5,5-6-7-8-10-12-13 mm

866LP

inserti per avvitatori per viti a testa con intaglio



ISO 2351-1
ISO 1173 C 8

SxA mm	L mm	€	10	50
1x5,5	41	3,05	10	008660005
1,2x6,5	41	3,05	10	008660010
1,6x8	41	3,05	10	008660015
1,6x10	41	4,05	10	008660020
2x12	41	5,10	10	008660025

866PH

inserti per avvitatori per viti con impronta a croce Phillips®



ISO 2351-2
ISO 1173 C 8

PH	L mm	€	10	50
1	32	2,45	10	008660200
2	32	2,45	10	008660205
3	32	2,45	10	008660210
4	38	3,70	10	008660215

866PZ

inserti per avvitatori per viti con impronta a croce Pozidriv® - Supadriv®



ISO 2351-2
ISO 1173 C 8

PZ	L mm	€	10	50
1	32	2,55	10	008660300
2	32	2,55	10	008660305
3	32	2,55	10	008660310
4	38	3,85	10	008660315

866PE

inserti maschio esagonale per avvitatori



ISO 2351-3

ISO 1173 C 8

mm	L mm	€	10	50
3	30	2,10	10	008660100
4	30	2,10	10	008660105
5	30	2,10	10	008660110
6	30	2,10	10	008660115
7	30	2,10	10	008660117
8	30	2,10	10	008660120
10	30	2,95	10	008660125
12	30	4,05	10	008660132
14	30	5,30	10	008660134

866TX

inserti per avvitatori per viti con impronta Torx®



ISO 1173 C 8

	L mm	€	10	50
T20	30	2,65	10	008660400
T25	30	2,65	10	008660405
T27	30	2,65	10	008660410
T30	30	2,65	10	008660415
T40	30	2,65	10	008660420
T45	30	2,65	10	008660425
T50	30	2,65	10	008660430
T55	30	3,80	10	008660435
T60	30	5,10	10	008660440
T70	30	5,70	10	008660445

866RTX

inserti per avvitatori per viti con impronta Tamper Resistant Torx®



ISO 1173 C 8

	L mm	€	10	50
T40	30	3,05	10	008660520
T45	30	3,05	10	008660525
T50	30	3,05	10	008660530
T55	30	4,25	10	008660535
T60	30	5,50	10	008660540
T70	30	6,80	10	008660545

867PE

inserti maschio esagonale



mm	L mm	€	10	50
4	30	1,38	5	008670104
5	30	1,38	5	008670105
6	30	1,38	5	008670106
7	30	1,38	5	008670107
8	30	1,38	5	008670108
10	30	1,38	5	008670110
12	30	2,05	5	008670112

867PE/L

inserti maschio esagonale



mm	L mm	€	10	50
4	75	2,55	5	008670154
5	75	2,55	5	008670155
6	75	2,55	5	008670156
7	75	2,55	5	008670157
8	75	2,55	5	008670158
10	75	2,55	5	008670160
12	75	3,60	5	008670162

867XZN

inserti a profilo XZN®



	L mm	€	10	50
M4	30	1,73	5	008670204
M5	30	1,73	5	008670205
M6	30	1,73	5	008670206
M8	30	1,73	5	008670208
M10	30	1,73	5	008670210
M12	30	2,55	5	008670212

867XZN/L

inserti a profilo XZN®



	L mm	€	10	50
M5	75	2,85	5	008670255
M6	75	2,85	5	008670256
M8	75	2,85	5	008670258
M10	75	2,85	5	008670260
M12	75	3,85	5	008670262

Beta
Quality Tools

867TX

inserti per viti con impronta Torx®



Ø	L mm	€	5	10
T20	30	1,38	5	008670400
T25	30	1,38	5	008670405
T30	30	1,38	5	008670410
T40	30	1,38	5	008670415
T45	30	1,38	5	008670420
T50	30	1,38	5	008670425
T55	30	1,38	5	008670430

867TX/L

inserti per viti con impronta Torx®



Ø	L mm	€	5	10
T20	75	2,25	5	008670450
T25	75	2,25	5	008670455
T30	75	2,25	5	008670460
T40	75	2,25	5	008670465
T45	75	2,25	5	008670470
T50	75	2,25	5	008670475
T55	75	2,25	5	008670480

867RTX

inserti per viti con impronta
Tampor Resistant Torx®



Ø	L mm	€	5	10
T20	30	1,53	5	008670500
T25	30	1,53	5	008670505
T30	30	1,53	5	008670510
T40	30	1,53	5	008670515
T45	30	1,53	5	008670520
T50	30	1,53	5	008670525
T55	30	1,53	5	008670530

867RTX/L

inserti per viti con impronta
Tampor Resistant Torx®



Ø	L mm	€	5	10
T20	75	2,55	5	008670550
T25	75	2,55	5	008670555
T30	75	2,55	5	008670560
T40	75	2,55	5	008670565
T45	75	2,55	5	008670570
T50	75	2,55	5	008670575
T55	75	2,55	5	008670580

867RIBE

inserti per avvitatori
per viti con impronta RIBE®



Ø	L mm	€	5	10
M5	30	1,58	5	008670705
M6	30	1,58	5	008670706
M7	30	1,58	5	008670707
M8	30	1,58	5	008670708
M9	30	1,58	5	008670709
M10	30	1,58	5	008670710
M11	30	2,30	5	008670711
M12	30	2,30	5	008670712
M13	30	2,30	5	008670713

867RIBE/L

inserti per avvitatori
per viti con impronta RIBE®



Ø	L mm	€	5	10
M5	75	2,55	5	008670755
M6	75	2,55	5	008670756
M7	75	2,55	5	008670757
M8	75	2,55	5	008670758
M9	75	2,55	5	008670759
M10	75	2,55	5	008670760
M11	75	3,45	5	008670761
M12	75	3,45	5	008670762
M13	75	3,45	5	008670763

867/...

bussole portainseri per 867



Ø	L	Ø	€	5	10		
867/1	10	3/8"	38	17	4,90	5	008670600
867/2	10	1/2"	38	22	5,60	5	008670601

867/C20

18 inserti con impronta RIBE® con attacco
esagonale 10 mm e 2 accessori



867/C20	€	5	10
867/C20	96,50	1	008670920
867RIBE	5-6-7-8-9-10-11-12-13 mm		
867RIBE/L	5-6-7-8-9-10-11-12-13 mm		
867/1			
867/2			

335x145x60 mm - 1,7 kg

867/C38

38 inserti con attacco esagonale 10 mm e 1
portainseri a T snodato



867/C38	€	5	10
867/C38	175,50	1	008670938

852	10 mm
867PE	4-5-6-7-8-10-12mm
867PE/L	4-5-6-7-8-10-12mm
867XZN	M5-M6-M8-M10-M12
867XZN/L	M5-M6-M8-M10-M12
867TX	T20-T25-T30-T40-T45-T50-T55
867TX/L	T20-T25-T30-T40-T45-T50-T55
882	

420x185x60 mm - 3 kg

867/C52

52 inserti con attacco esagonale 10 mm
e 2 accessori



867/C52	€	5	10
867/C52	112,00	1	008670901

867PE	4-5-6-7-8-10-12 mm
867PE/L	4-5-6-7-8-10-12 mm
867XZN	M5-M6-M8-M10-M12
867XZN/L	M5-M6-M8-M10-M12
867TX	T20-T25-T30-T40-T45-T50-T55
867TX/L	T20-T25-T30-T40-T45-T50-T55
867RTX	T20-T25-T30-T40-T45-T50-T55
867RTX/L	T20-T25-T30-T40-T45-T50-T55
867/1	10 mm - 3/8"
867/2	10 mm - 1/2"

250x170x70 mm - 2,1 kg

852



852	79,114
-----	--------

882

portainseri con anello di ritegno per avvitatori



ISO 1173 E 6,3

L mm	□	●	Ø mm	€	🔧	📦
57	1/4	1/4	11	13,70	5	008820001

882AN

rinvio angolare attacco esagonale 1/4"

- Per trapani elettrici con mandrino da 10 e 13 mm e avvitatori con attacco da 1/4"
- Velocità max 3600 giri/min.
- Coppia massima 30 Nm
- Con porta-inseri a cambio rapido
- Rapporto di trasmissione 1:1
- Collegamento all'utensile mediante esagono 1/4" D6.3



ISO 1173 E 6,3
ISO 1173 C 6,3

L mm	□	●	€	🔧	📦
137	1/4	1/4	60,00	1	008820090

882M1

portainseri magnetico per avvitatori



ISO 1173 E 6,3

L mm	□	●	Ø mm	€	🔧	📦
50	1/4	1/4	11	14,50	5	008820006

882M

portainseri magnetico per avvitatori



ISO 1173 E 6,3

L mm	□	●	Ø mm	€	🔧	📦
75	1/4	1/4	11	17,50	5	008820005

882MSR

portainseri magnetico a sgancio rapido per avvitatori



ISO 1173 E 6,3

L mm	□	●	Ø mm	€	🔧	📦
50	1/4	1/4	11	15,70	5	008820205
75	1/4	1/4	11	18,30	5	008820207

882P

prolunga portainseri magnetica



L mm	□	●	Ø mm	€	🔧	📦
80	1/4	1/4	10	12,80	5	008820080

892

raccordi per avvitatori



892/0	□	●	L mm	€	🔧	📦
892/0	1/4	1/4	25	4,55	5	008920000
* 892/1	1/4	5,5	50	8,60	5	008920001
* 892/2	3/8	5,5	50	12,70	5	008920002
* 892/3	1/4	1/4	50	8,60	5	008920003
° 892/4	3/8	1/4	50	12,70	5	008920004
892/5	1/4	5/16	75	11,80	5	008920005
892/6	3/8	5/16	75	17,40	5	008920006
892/7	1/2	1/4	75	17,90	5	008920007

* ISO 1173 A 5,5
° ISO 1173 C 6,3

895

bussole portainseri per 860, 861, 862, 866



DIN 7427

	○	□	L mm	Ø mm	€	🔧	📦
895/1	1/4	1/4	25,4	12	10,30	5	008950000
895/3	1/4	3/8	29	16,8	12,20	5	008950001
895/4	5/16	3/8	29	16,8	12,20	5	008950002
895/5	1/4	1/2	38	22	12,20	5	008950005
895/6	5/16	1/2	38	22	12,20	5	008950003

897

portainseri flessibile con impugnatura



L mm	L1 mm	€	🔧	📦
280	154	23,50	2	008970010

897L

portainseri flessibile con impugnatura modello lungo



L mm	L1 mm	€	🔧	📦
500	380	27,00	2	008970015

900

chiavi a bussola a mano bocca esagonale



UNI/ISO 2725 DIN 3124

mm	Ø mm	L mm	Ø1 mm	€	🔧	📦
3,2	6,6	25	11,8	3,40	10	009000032
4	6,8	25	11,8	3,40	10	009000040
4,5	7,4	25	11,8	3,40	10	009000045
5	8,0	25	11,8	3,40	10	009000050
5,5	8,7	25	11,8	3,40	10	009000055
6	9,3	25	11,8	3,40	10	009000060
7	10,4	25	11,8	3,40	10	009000070
8	11,8	25	12,7	3,40	10	009000080
9	12,7	25	11,8	3,40	10	009000090
10	14,2	25	12,0	3,40	10	009000100
11	15,8	25	12,5	3,40	10	009000110
12	17,2	25	13,5	3,40	10	009000120
13	18,0	25	13,5	3,45	10	009000130
14	20,0	25	15,0	3,50	10	009000140



900/SB13	€	🔧	📦
4-4,5-5-5,5-6-7-8-9 10-11-12-13-14 mm	57,50	1	009000150

900U

chiavi a bussola a mano
bocca multimpronta

1/4"



mm	"	♂	♀	€	🔧	📦
4	5/32	E5	M5	3,60	5	009001702
4,5	3/16	E6		3,60	5	009001703
5	13/64		M6	3,60	5	009001704
5,5	7/32	E7		3,60	5	009001705
6	1/4	E8	M8	3,60	5	009001706
7	9/32			3,60	5	009001707
8	5/16	E10	M10	3,60	5	009001708
9	11/32			3,60	5	009001709
10	3/8	E12	M12	3,60	5	009001710
11	7/16	E14	M14	3,60	5	009001711
12	15/32	E16		3,60	5	009001712
13	1/2		M16	3,65	5	009001713
14	9/16	E18	M18	3,70	5	009001714

1/4"



900U/SB13 € 60,00 1 009001750
4-4,5-5-5,5-6-7-8-9
10-11-12-13-14 mm

900FTX

chiavi a bussola a mano per viti
con teste a profilo Torx®

1/4"



♂	♀	Ø	L	Ø1	€	🔧	📦
mm	mm	mm	mm	mm			
E4		5,4	22	11,2	6,35	5	009000404
E5		6,7	22	11,2	6,35	5	009000405
E6		7,7	22	11,2	6,35	5	009000406
E7		8,3	22	11,2	6,35	5	009000407
E8		9,6	22	11,2	6,35	5	009000408
E10		11,3	22	12,0	6,35	5	009000410
E11		12,1	22	12,5	8,70	5	009000411
E12		12,9	23	12,9	8,70	5	009000412
E14		14,0	25	14,0	8,70	5	009000414

1/4"



900FTX/SB9 € 74,00 1 009000419
E4-E5-E6-E7-E8
E10-E11-E12-E14

900LP

chiavi a bussola a giravite
per viti con intaglio

1/4"



SxA	Ø	L	L1	€	🔧	📦
mm	mm	mm	mm			
0,8x4	12	28	9	7,70	5	009000605
1x5,5	12	28	9	7,70	5	009000610
1,2x6,5	12	28	9	7,70	5	009000615
1,2x8	13	28	8	7,70	5	009000620
1,6x10	14	28	8	7,70	5	009000625

900MC/LP

chiavi a bussola a giravite
per viti con intaglio colorate



SxA	Ø	L	L1	€	🔧	📦
mm	mm	mm	mm			
0,8x4	12	28	9	12,00	3	009002605
1,2x6,5	12	28	9	12,00	3	009002615
1,2x8	13	28	8	12,00	3	009002620

900PH

chiavi a bussola a giravite
per viti con impronta a croce Phillips®

1/4"



PH	Ø	L	L1	€	🔧	📦
	mm	mm	mm			
1	12	28	12	8,40	5	009000701
2	12	28	12	8,40	5	009000702
3	12	28	12	8,40	5	009000703
4	13	28	11	8,40	5	009000704

1/4"



900PH/SB4 € 39,50 1 009000708
PH1-PH2-PH3-PH4

900MC/PH

chiavi a bussola a giravite
per viti con impronta a croce Phillips® colorate

1/4"



PH	Ø	L	L1	€	🔧	📦
mm	mm	mm	mm			
1	12	28	12	12,50	3	009002701
2	12	28	12	12,50	3	009002702
3	12	28	12	12,50	3	009002703

900PZ

chiavi a bussola a giravite
per viti con impronta a croce Pozidriv®-
Supadriv®

1/4"



PZ	Ø	L	€	🔧	📦
mm	mm	mm			
1	12	28	8,80	3	009000711
2	12	28	8,80	3	009000712
3	12	28	8,80	3	009000713

900ME

chiavi a bussola a giravite
maschio esagonale

1/4"



mm	Ø	L	L1	€	🔧	📦
	mm	mm	mm			
2,5	12	25	4,5	7,30	5	009000502
3	12	25	5,0	7,30	5	009000503
4	12	25	5,6	7,30	5	009000504
5	12	25	6,3	7,30	5	009000505
6	12	25	7,6	7,30	5	009000506
7	13	25	7,2	7,30	5	009000507
8	13	25	8,0	7,30	5	009000508
10	13	25	8,7	9,00	5	009000510

1/4"



900ME/SB8 € 69,00 1 009000518
2,5-3-4-5-6-7-8-10 mm

900PE/AS

chiavi a bussola maschio esagonale

1/4"



"	Ø	L	€	🔧	📦
mm	mm	mm			
1/8	11,9	25	16,50	5	009000521
5/32	11,9	25	16,50	5	009000522
3/16	11,9	25	16,50	5	009000523
7/32	11,9	25	16,50	5	009000524
1/4	11,9	25	16,50	5	009000525
9/32	13,1	25	16,50	5	009000526
5/16	13,	25	16,50	5	009000527

900PT

chiavi a bussola a giravite per viti con impronta pentalobata



Ø	L	L1	€	5	009000750
mm	mm	mm			
PT10	12	28	12	15,40	5 009000750
PT15	12	28	12	15,40	5 009000755
PT20	12	28	12	15,40	5 009000760
PT25	12	28	12	15,40	5 009000765
PT27	12	28	12	15,40	5 009000767
PT30	12	28	12	15,40	5 009000770

900TX

chiavi a bussola a giravite maschio per viti con impronta Torx®



Ø	L	L1	€	5	009000717
mm	mm	mm			
T6	12	28	12	11,20	5 009000717
T7	12	28	12	11,20	5 009000718
T8	12	28	12	11,30	5 009000719
T9	12	28	12	11,30	5 009000720
T10	12	28	12	11,30	5 009000721
T15	12	28	12	11,30	5 009000722
T20	12	28	12	11,30	5 009000723
T25	12	28	12	11,30	5 009000724
T27	12	28	12	11,30	5 009000725
T30	12	28	12	11,30	5 009000726
T40	12	28	12	11,30	5 009000727



900TX/SB8	€	1	009000730
T9-T10-T15-T20 T25-T27-T30-T40	99,50	1	009000730

900MC/TX

chiavi a bussola a giravite maschio per viti con impronta Torx® colorate



Ø	L	L1	€	3	009002721
mm	mm	mm			
T10	12	28	12	13,00	3 009002721
T15	12	28	12	13,00	3 009002722
T20	12	28	12	13,00	3 009002723
T25	12	28	12	13,00	3 009002724
T27	12	28	12	13,00	3 009002725
T30	12	28	12	13,00	3 009002726
T40	12	28	12	13,00	3 009002727

900/16

raccordo con attacco quadro femmina 1/4" e maschio 3/8"



UNI/ISO 3316 DIN 3123

L	Ø	1/4	3/8	€	5	009000814
mm	mm					
28	13,0	1/4	3/8	5,90	5	009000814

900/...

prolunghe con attacchi quadri maschio e femmina 1/4"

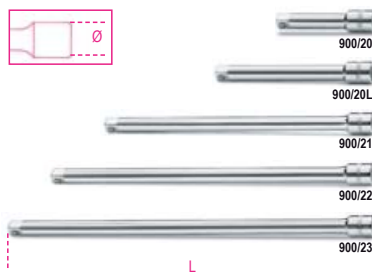

UNI/ISO 3316 DIN 3123

L	Ø	€	5	009000818
mm	mm			
900/20	50	11,5	7,50	5 009000818
900/20L	100	11,5	7,70	5 009000819
900/21	150	11,5	8,00	5 009000822
900/22	250	11,5	11,80	5 009000823
900/23	350	11,5	14,20	5 009000824

900AN

prolunghe con attacchi quadri maschio e femmina 1/4" angolari

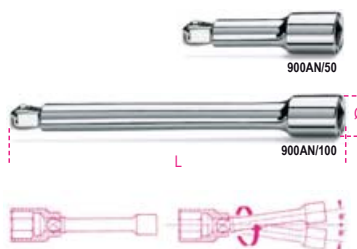

L	Ø	€	3	009000825
mm	mm			
900AN/50	50	11,5	8,10	3 009000825
900AN/100	100	11,5	8,90	3 009000826

900FL

prolunga flessibile con attacchi quadri maschio e femmina 1/4"

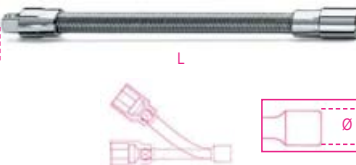

L	Ø	€	3	009000828
mm	mm			
150	12		11,90	3 009000828

900/25

snodo con attacchi quadri maschio e femmina 1/4"



UNI/ISO 3316 DIN 3123

L	Ø	€	5	009000830
mm	mm			
41	12,5		14,60	5 009000830

900BG/30C

quadro maschio 1/4" con impugnatura



UNI/ISO 3315 DIN 3122

L	L1	€	5	009000833
mm	mm			
128	20		7,20	5 009000833

900BG/30

quadro maschio 1/4" con impugnatura



UNI/ISO 3315 DIN 3122

L	L1	€	5	009000834
mm	mm			
176	68		7,50	5 009000834

900/32

quadro maschio 1/4" flessibile con impugnatura



L	L1	€	2	009000839
mm	mm			
280	154		17,20	2 009000839

900/35A

quadro maschio 1/4" snodato con impugnatura



UNI/ISO 3315 DIN 3122

L	L1	€	5	009000840
mm	mm			
148	84		24,50	5 009000840

900M/35

quadro maschio 1/4" snodato
con impugnatura in metallo



UNI/ISO 3315
DIN 3122

L
mm 130 € 32,00 3 009000845

900/40

quadro maschio 1/4" snodato a T



L L1
mm mm 390 145 € 33,00 3 009000843

900/42

quadro maschio 1/4"
con spina scorrevole

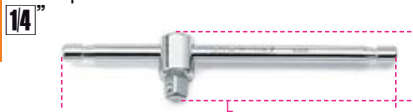

UNI/ISO 3315 DIN 3122

L A
mm mm 115 22 € 8,20 5 009000854

900T/44

quadro maschio 1/4" piegato
con impugnatura di manovra



L L1
mm mm 238 105 € 12,40 2 009000860

900/55

cricchetto reversibile
con attacco quadro maschio 1/4"
meccanismo a 48 denti



UNI/ISO 3315 DIN 3122

L Ø A
mm mm mm 125 25 29 € 39,50 5 009000870

900/55Z

cricchetto reversibile
con attacco quadro maschio 1/4"
meccanismo a 72 denti



L Ø A
mm mm mm 126 25 23 € 39,50 3 009000882

900M/55

cricchetto reversibile
con attacco quadro maschio 1/4"
con impugnatura in metallo



UNI/ISO 3315
DIN 3122

L Ø A
mm mm mm 110 22 18 € 50,50 3 009000905

**Meccanismi rotanti
di ricambio dei cricchetti,
vedi tabella dopo l'art. 929/C8**

900/58

cricchetto reversibile
con impugnatura rotante
con attacco quadro maschio 1/4"
meccanismo a 52 denti

- Pulsante di rilascio della bussola
- Sistema di inversione a ghiera sulla testa del cricchetto
- Impugnatura bimatériale



L Ø A
mm mm mm 126 28 28,5 € 60,00 2 009000884

900/C39

11 chiavi a bussola esagonali, 21 inserti e 7 accessori



900/C39 € 168,00 1 009000937

- 861LP 0,6x4,5 - 1,2x6,5 - 1,2x8 mm
- 861PH PH1-PH2-PH3
- 861PZ PZ1-PZ2-PZ3
- 861PE 2,5-3-4-5-6 mm
- 861RTX T10-T15-T20-T25-T27-T30-T40
- 900 5-5,5-6-7-8-9-10-11-12-13-14 mm
- 900/20 50 mm
- 900/20L 100 mm
- 900/25
- 900BG/30C 128 mm
- 900/55
- 892/0
- 895/1

900/C11

11 chiavi a bussola esagonali,
20 inserti per avvitatori e 8 accessori



900/C11 € 186,00 1 009000971

- 861LP 0,5x3 - 0,8x5,5
1x5,5 - 1,2x6,5 mm
- 861PE 3 - 4 - 5 - 6 - 8 mm
- 861PH 0 - 1 - 2 - 3
- 861TX T8 - T10 - T15 - T20
T25 - T30 - T40
- 895/1
- 900 5 - 5,5 - 6 - 7 - 8 - 9 - 10
11 - 12 - 13 - 14 mm
- 900/16 □ 1/4 - ■ 3/8
- 900/20 50 mm
- 900/21 150 mm
- 900/25
- 900BG/30
- 900/42
- 900/55

270x120x45 mm - 1,2 kg



900/C11Z

11 chiavi a bussola esagonali,
20 inserti per avvitatori e 8 accessori

14"
1/4"



900/C11Z € 186,00 1 009000984

	861LP	0,5x3 - 0,8x5,5 - 1x5,5 - 1,2x6,5 mm
	861PE	3 - 4 - 5 - 6 - 8 mm
	861PH	0 - 1 - 2 - 3
	861TX	T8 - T10 - T15 - T20 T25 - T30 - T40
	895/1	
	900	5 - 5,5 - 6 - 7 - 8 - 9 - 10 11 - 12 - 13 - 14 mm
	900/16	□ 1/4 - ■ 3/8
	900/20	50 mm
	900/21	150 mm
	900/25	
	900BG/30	
	900/42	
	900/55Z	

≡ 350x150x50 mm - 1,2 kg

900/C13-5

13 chiavi a bussola esagonali
e 5 accessori

14"



900/C13-5 € 147,00 1 009000953

	900	4 - 4,5 - 5 - 5,5 - 6 - 7 - 8 - 9 10 - 11 - 12 - 13 - 14 mm
	900/21	150 mm
	900/25	
	900BG/30	
	900/42	
	900/55	

≡ 270x120x45 mm - 1 kg

900/C13-8

13 chiavi a bussola esagonali
e 8 accessori

14"



900/C13-8 € 185,00 1 009000954

	900	4 - 4,5 - 5 - 5,5 - 6 - 7 - 8 - 9 10 - 11 - 12 - 13 - 14 mm
	900/16	□ 1/4 - ■ 3/8
	900/20	50 mm
	900/21	150 mm
	900/25	
	900BG/30	
	900/35A	
	900/42	
	900/55	

≡ 270x120x45 mm - 1,1 kg



900MB/C19

11 chiavi a bussola poligonali
e 8 accessori

14"



900MB/C19 € 216,00 1 009000977

	900MB	5 - 5,5 - 6 - 7 - 8 - 9 - 10 - 11 12 - 13 - 14 mm
	900/16	□ 1/4 - ■ 3/8
	900/20	50 mm
	900/21	150 mm
	900/25	
	900BG/30	
	900/35A	
	900/42	
	900/55	

≡ 270x120x45 mm - 1,1 kg

900/C24

13 chiavi a bussola esagonali
11 a giravite e 6 accessori

14"



900/C24 € 239,50 1 009000956

	900	4 - 4,5 - 5 - 5,5 - 6 - 7 - 8 - 9 10 - 11 - 12 - 13 - 14 mm
	900LP	0,8x4 - 1,2x6,5 - 1,2x8 mm
	900PH	PH1 - PH2 - PH3
	900ME	3 - 4 - 5 - 6 - 8 mm
	900/20	50 mm
	900/21	150 mm
	900/25	
	900BG/30	
	900/42	
	900/55	

≡ 270x120x45 mm - 1,1 kg

900/C12MZ

12 chiavi a bussola esagonali,
20 inserti per avvitatori e 7 accessori
in termoformato morbido

14"
1/4"



900/C12MZ € 188,50 1 009000983

	900	4-5-5,5-6-7-8-9-10-11-12-13-14 mm
	900/20	50 mm
	900/21	150 mm
	900/25	
	900/42	115 mm
	900BG/30	128 mm
	900/55Z	
	895/1	
	861TX	T8-T10-T15-T20-T25-T30-T40
	861PH	PH0-PH1-PH2-PH3
	861LP	0,5x3 - 0,8x5,5 - 1x5,5 - 1,2x6,5 mm
	861PE	3-4-5-6-8 mm

≡ 350x150x50 mm - 1,2 kg

900MC/C24

11 chiavi a bussola esagonali colorate
13 a giravite colorate e 6 accessori

1/4"



900MC/C24

€ 316,00

1 009002960

	900MC	4 - 5 - 6 - 7 - 8 - 9 10 - 11 - 12 - 13 - 14 mm
	900MC/PH	PH1 - PH2 - PH3
	900MC/TX	T10 - T15 - T20 - T25 - T27 - T30 - T40
	900MC/LP	0,8x4 - 1,2x6,5 - 1,2x8 mm
	900/20	50 mm
	900/21	150 mm
	900/25	
	900BG/30	
	900/42	
	900/55	
≡ 270x120x45 mm - 1 kg		

900MB/C28

11 chiavi a bussola poligonali
11 a giravite e 6 accessori

1/4"



900MB/C28

€ 271,00

1 009000979

	900MB	5 - 5,5 - 6 - 7 - 8 - 9 - 10 - 11 12 - 13 - 14 mm
	900LP	0,8x4 - 1,2x6,5 - 1,2x8 mm
	900PH	PH1 - PH2 - PH3
	900ME	3 - 4 - 5 - 6 - 8 mm
	900/20	50 mm
	900/21	150 mm
	900/25	
	900BG/30	
	900/42	
	900/55	
≡ 270x120x45 mm - 1,1 kg		

900MC/C32

11 chiavi a bussola esagonali colorate,
20 inserti colorati per avvitatori e 7 accessori

1/4"



900MC/C32

€ 200,00

1 009002963

	900MC	4 - 5 - 6 - 7 - 8 - 9 - 10 - 11 - 12 - 13 - 14 mm
	860LP	0,5x3 - 0,8x5,5 - 1,0x5,5 - 1,2x6,5 mm
	860PH	0 - 1 - 2 - 3
	860PE	3 - 4 - 5 - 6 - 8 mm
	860TX	T8 - T10 - T15 - T20 - T25 - T30 - T40
	895/1	
	900/20	
	900/21	
	900/25	
	900BG/30	
	900/42	
	900/55	
≡ 270x120x45 mm - 1,2 kg		

900AS/C10 - /MB-C17

10 chiavi a bussola
e 7 accessori

1/4"



900AS/C10

€ 172,50

1 009000961

	900AS	3/16 - 7/32 - 1/4 - 9/32 - 5/16 11/32 - 3/8 - 7/16 - 1/2 - 9/16
	900/20	50 mm
	900/21	150 mm
	900/25	
	900BG/30	
	900/35A	
	900/42	
	900/55	
≡ 270x120x45 mm - 1,1 kg		

900AS/MB-C17

€ 206,50

1 009000981

	900AS/MB	3/16 - 7/32 - 1/4 - 9/32 - 5/16 11/32 - 3/8 - 7/16 - 1/2 - 9/16
	900/20	50 mm
	900/21	150 mm
	900/25	
	900BG/30	
	900/35A	
	900/42	
	900/55	
≡ 270x120x45 mm - 1,1 kg		

900AS/C17-MBM

10 chiavi a bussola poligonali
e 7 accessori
per manutenzioni aeronautiche

1/4"



900AS/C17-MBM

€ 225,00

1 009000982

	900AS/MB	3/16 - 7/32 - 1/4 - 9/32 - 5/16 11/32 - 3/8 - 7/16 - 1/2 - 9/16
	900/20	50 mm
	900/21	150 mm
	900/25	
	900BG/30	
	900M/35	
	900/42	
	900M/55	
≡ 270x120x45 mm - 1,2 kg		

900/C11HR

11 chiavi a bussola esagonali,
20 inserti per avvitatori e 7 accessori
in termoformato rigido,
in cassetta di lamiera

• cricchetto con impugnatura rotante

1/4"



900/C11HR

€ 206,50

1 009000980

	861LP	0,5x3-0,8x5,5-1x5,5-1,2x6,5 mm
	861PH	PH0-PH1-PH2-PH3
	861PE	3-4-5-6-8 mm
	861TX	T8-T10-T15-T20-T25-T30-T40
	895/1	
	900	5-5,5-6-7-8-9-10-11-12-13-14 mm
	900/16	□ 1/4 - ■ 3/8
	900/20	50 mm
	900/21	150 mm
	900/25	
	900/42	
	900BG/30	
	900/55	
≡ 350x150x50 mm - 1,3 kg		

902R/C6

6 raccordi per chiavi a bussola



902R/C6 € 80,50 1 009020814

- 900/16 □ 1/4 - ■ 3/8
- 910/15 □ 3/8 - ■ 1/4
- 910/16 □ 3/8 - ■ 1/2
- 920/15 □ 1/2 - ■ 3/8
- 920/16 □ 1/2 - ■ 3/4
- 928/15 □ 3/4 - ■ 1/2

170x100x35 mm - 600 g

910A

chiavi a bussola a mano
bocca esagonale



UNI/ISO 2725 DIN 3124

Ø mm	Ø mm	L mm	Ø1 mm	€	5	10
6	9,5	28	16,7	5,50	5	009100006
7	10,7	28	16,7	5,50	5	009100007
8	12,1	28	16,7	5,50	5	009100008
9	13,2	28	16,7	5,50	5	009100009
10	14,6	29	16,7	5,50	5	009100010
11	15,8	29	16,7	5,50	5	009100011
12	17,2	30	17,7	5,70	5	009100012
13	18,4	31	17,0	5,70	5	009100013
14	19,7	32	17,5	5,70	5	009100014
15	20,9	32	18,0	5,70	5	009100015
16	22,2	33	18,5	6,40	5	009100016
17	23,2	33	19,0	6,40	5	009100017
18	24,7	34	20,0	6,40	5	009100018
19	25,8	35	21,0	6,40	5	009100019
20	27,2	35	22,0	6,90	5	009100020
21	28,2	36	23,0	6,90	5	009100021
22	29,7	37	24,0	7,00	5	009100022



910A/SB17 € 119,00 1 009100030

6-7-8-9-10-11-12
13-14-15-16-17
18-19-20-21-22 mm

910B

chiavi a bussola a mano
bocca poligonale



UNI/ISO 2725 DIN 3124

Ø mm	Ø mm	L mm	Ø1 mm	€	5	10
6	9,5	28	16,7	5,50	5	009100106
7	10,7	28	16,7	5,50	5	009100107
8	12,1	28	16,7	5,50	5	009100108
9	13,2	28	16,7	5,50	5	009100109
10	14,6	29	16,7	5,50	5	009100110
11	15,8	29	16,7	5,50	5	009100111
12	17,2	30	17,7	5,70	5	009100112
13	18,4	31	17,0	5,70	5	009100113
14	19,7	32	17,5	5,70	5	009100114
15	20,9	32	18,0	5,70	5	009100115
16	22,2	33	18,5	6,40	5	009100116
17	23,2	33	19,0	6,40	5	009100117
18	24,7	34	20,0	6,40	5	009100118
19	25,8	35	21,0	6,40	5	009100119
20	27,2	35	22,0	6,90	5	009100120
21	28,2	36	23,0	6,90	5	009100121
22	29,7	37	24,0	7,00	5	009100122



910B/SB17 € 119,00 1 009100130

6-7-8-9-10-11-12
13-14-15-16-17
18-19-20-21-22 mm

910AL

chiavi a bussola a mano lunghe
bocca esagonale



UNI/ISO 2725 DIN 3124

Ø mm	Ø mm	L mm	Ø1 mm	€	5	10
8	12,0	55	17	11,50	3	009100158
9	13,0	55	17	11,50	3	009100159
10	14,5	55	17	11,50	3	009100160
11	16,0	55	17	11,50	3	009100161
12	17,0	55	17	11,50	3	009100162
13	18,0	55	17	12,50	3	009100163
14	20,0	55	18	12,50	3	009100164
15	21,0	55	20	12,50	3	009100165
16	22,0	55	20	12,50	3	009100166
17	23,5	55	22	12,50	3	009100167
18	24,5	55	23	13,80	2	009100168
19	25,0	55	24	13,80	2	009100169
21	27,0	65	26	14,80	2	009100171
22	29,0	65	28	14,80	2	009100172



910AL/SB14 € 191,50 1 009100174

8-9-10-11-12-13-14
15-16-17-18-19-21-22 mm

910BL

chiavi a bussola a mano lunghe
bocca poligonale



UNI/ISO 2725 DIN 3124

Ø mm	Ø mm	L mm	Ø1 mm	€	5	10
8	12,0	55	17	11,50	3	009100308
9	13,0	55	17	11,50	3	009100309
10	14,5	55	17	11,50	3	009100310
11	16,0	55	17	11,50	3	009100311
12	17,0	55	17	11,50	3	009100312
13	18,0	55	17	12,50	3	009100313
14	20,0	55	18	12,50	3	009100314
15	21,0	55	20	12,50	3	009100315
16	22,0	55	20	12,50	3	009100316
17	23,5	55	22	12,50	3	009100317
18	24,5	55	23	13,80	2	009100318
19	25,0	55	24	13,80	2	009100319
21	27,0	65	26	14,80	2	009100321
22	29,0	65	28	14,80	2	009100322



910BL/SB14 € 191,50 1 009100340

8-9-10-11-12-13
14-15-16-17-18
19-21-22 mm

910B/SN

chiavi a bussola a mano snodate
bocca poligonale



Ø mm	Ø mm	L mm	Ø1 mm	€	5	10
10	14,5	48,5	19	30,00	2	009100230
11	15,8	49,5	19	30,00	2	009100231
12	17,0	50,0	19	30,00	2	009100232
13	18,3	51,0	19	30,00	2	009100233
14	19,5	51,0	19	33,00	2	009100234
15	20,8	53,5	19	33,00	2	009100235
16	22,0	53,5	19	33,00	2	009100236
17	23,3	54,5	19	33,00	2	009100237
18	24,5	54,5	19	33,00	2	009100238
19	25,8	56,5	19	33,00	2	009100239

910A/AS

chiavi a bussola a mano
bocca esagonale



Ø mm	Ø mm	L mm	Ø1 mm	€	5	10
1/4	10,3	26	17,3	6,50	5	009100276
5/16	11,9	26	17,3	6,50	5	009100278
11/32	13,3	26	17,3	6,50	5	009100279
3/8	13,9	26	17,3	6,50	5	009100280
7/16	15,8	26	17,3	6,50	5	009100281

"	Ø mm	L mm	Ø1 mm	€		
1/2	17,9	26	17,3	6,70	5	009100283
9/16	19,5	27	18,5	6,70	5	009100284
19/32	20,6	27	19,5	6,70	5	009100285
5/8	21,9	28	20,0	7,20	5	009100286
11/16	24,6	30	22,5	7,20	5	009100287
3/4	25,9	30	23,5	7,20	5	009100289
13/16	27,9	32	26,0	8,00	5	009100291
7/8	29,6	32	26,5	8,30	5	009100292



910A-AS/SB13 € 104,00 1 009100295
1/4-5/16-11/32-3/8-7/16
1/2-9/16-19/32-5/8-11/16
3/4-13/16-7/8

910AS

chiavi a bussola a mano
bocca poligonale



"	Ø mm	L mm	Ø1 mm	€		
1/4	9,5	28	16,7	6,50	5	009100201
5/16	12,1	28	16,7	6,50	5	009100202
11/32	13,2	28	16,7	6,50	5	009100203
3/8	14,6	29	16,7	6,50	5	009100204
7/16	15,8	29	16,7	6,50	5	009100205
1/2	18,4	31	17,0	6,70	5	009100206
9/16	19,7	32	17,5	6,70	5	009100207
19/32	20,9	32	18,0	6,70	5	009100208
5/8	22,2	33	18,5	7,20	5	009100209
11/16	24,7	34	20,0	7,20	5	009100210
3/4	25,8	35	21,0	7,20	5	009100211
13/16	28,2	36	23,0	8,00	5	009100212
7/8	29,7	37	24,0	8,30	5	009100213



910AS/SB13 € 104,00 1 009100215
1/4-5/16-11/32-3/8-7/16
1/2-9/16-19/32-5/8-11/16
3/4-13/16-7/8

910AS/L

chiavi a bussola a mano lunghe
bocca poligonale



"	Ø mm	L mm	Ø1 mm	€		
1/4	10	55	17	14,50	3	009100350
5/16	12	55	17	14,50	3	009100351
3/8	14	55	17	14,50	3	009100352
7/16	16	55	17	14,50	3	009100353
1/2	18	55	17	16,00	3	009100354
9/16	20	55	18	16,00	3	009100355
19/32	21	55	20	16,50	3	009100356
5/8	22	55	20	16,50	3	009100357
11/16	23	55	22	16,50	3	009100359
3/4	25	55	24	17,50	3	009100360
13/16	27	65	26	20,50	3	009100362
7/8	29	65	28	20,50	3	009100363



910ASL/SB12 € 211,00 1 009100365
1/4-5/16-3/8-7/16
1/2-9/16-19/32-5/8-11/16
3/4-13/16-7/8

910AS/SN

chiavi a bussola a mano snodate
bocca poligonale



* SAE AS 954E

"	Ø mm	L mm	Ø1 mm	€		
* 3/8	14,0	48,0	19	32,50	2	009100260
* 7/16	15,8	51,0	19	32,50	2	009100261
* 1/2	18,3	51,0	19	32,50	2	009100262
* 9/16	19,5	51,0	19	33,00	2	009100263
* 5/8	22,0	53,5	19	33,00	2	009100264
11/16	24,5	54,5	19	35,00	2	009100265
3/4	25,8	56,5	19	35,00	2	009100266

910FTX

chiavi a bussola a mano per viti
con testa a profilo Torx®



"	Ø mm	L mm	Ø1 mm	€		
E4	6,2	26	17,3	7,70	5	009100404
E5	7,0	26	17,3	7,70	5	009100405
E6	8,3	26	17,3	7,70	5	009100406
E7	8,9	26	17,3	7,70	5	009100407
E8	9,9	26	17,3	7,70	5	009100408
E10	12,0	26	17,3	7,70	5	009100410
E11	13,3	26	17,3	7,70	5	009100411
E12	14,5	26	17,3	7,70	5	009100412
E14	15,8	26	17,3	7,70	5	009100414
E16	18,0	26	17,3	7,70	5	009100416
E18	19,5	26	18,5	8,50	3	009100418
E20	21,9	26	20,0	8,50	3	009100420



910FTX/SB9 € 79,00 1 009100430
E4-E5-E6-E7-E8
E10-E12-14-E16

910FTX/L

chiavi a bussola a mano lunghe per viti
con testa a profilo Torx®



"	Ø mm	L mm	Ø1 mm	€		
E4	6,2	55	17,3	17,30	3	009100440
E5	7,0	55	17,3	17,30	3	009100441
E6	8,3	55	17,3	17,30	3	009100442
E7	8,9	55	17,3	17,30	3	009100443
E8	9,9	55	17,3	17,30	3	009100444
E10	12,0	55	17,3	17,30	3	009100445



910FTX-L/SB6 € 111,50 1 009100449
E4-E5-E6
E7-E8-E10

910FTX/XL

chiavi a bussola a mano extra-lunghe per viti
con testa a profilo Torx®



"	Ø mm	L mm	Ø1 mm	€		
E6	8,0	200	18	15,50	2	009100766
E7	8,0	200	18	15,50	2	009100767
E8	10,0	200	18	15,50	2	009100768
E10	14,0	200	18	15,50	2	009100770
E11	14,0	200	18	15,50	2	009100771
E12	14,0	200	18	15,50	2	009100772
E14	17,0	200	18	17,00	2	009100774
E16	18,6	200	18	17,00	2	009100776
E18	21,5	200	18	18,00	2	009100778
E20	21,5	200	18	18,00	2	009100780

910FTX-XL/C10

10 chiavi a bussola per viti con impronta Torx®
tipo lungo
in cassetta di plastica



910FTX-XL/C10 € 163,00 1 009100976
E6-E7-E8-E10-E11-
E12-E14-E16-E18-E20

255x195x62 mm - 2,3 kg

910LP

chiavi a bussola a giravite per viti con intaglio



SxA mm	Ø mm	L mm	L1 mm	€	🔧	📦
1x5,5	18,5	54	24	13,60	2	009100452
1,2x6,5	18,5	54	24	13,60	2	009100453
1,2x8	18,5	54	24	13,60	2	009100454
1,6x9	18,5	54	24	13,60	2	009100456

910PH

chiavi a bussola a giravite per viti con impronta a croce Phillips®



PH	Ø mm	L mm	L1 mm	€	🔧	📦
1	18,5	48	18	12,60	2	009100471
2	18,5	48	18	12,60	2	009100472
3	18,5	48	18	12,60	2	009100473
4	18,5	48	18	12,60	2	009100474



910PH/SB4	€	🔧	📦
PH1-PH2-PH3-PH4	56,50	1	009100478

910PE

chiavi a bussola maschio esagonale

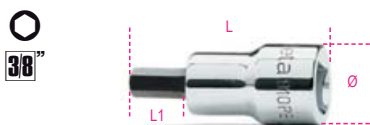

DIN 7422

mm	Ø mm	L mm	L1 mm	€	🔧	📦
3	18,5	50	20	11,00	5	009100490
4	18,5	50	20	11,00	5	009100492
5	18,5	50	20	11,00	5	009100494
6	18,5	50	20	11,00	5	009100496
7	18,5	50	20	11,00	5	009100497
8	18,5	50	20	11,00	5	009100498
9	18,5	50	20	11,00	5	009100499
10	18,5	50	20	11,00	5	009100500



910PE/SB7	€	🔧	📦
3-4-5-6-7-8-10 mm	85,50	1	009100503

910BP

chiavi a bussola maschio esagonale con estremità sferica



mm	L mm	L1 mm	€	🔧	📦
4L	92	62	13,20	3	009100584
5L	92	62	13,20	3	009100585
6L	92	62	13,20	3	009100586
7L	92	62	13,20	3	009100587
8L	92	62	13,20	3	009100588
10L	132	102	14,30	3	009100590



910BP/SB6L	€	🔧	📦
4L-5L-6L-7L-8L-10L mm	88,00	1	009100596

910ME

chiavi a bussola maschio esagonale



mm	Ø mm	L mm	L1 mm	€	🔧	📦
4	18	62	15	13,30	5	009100504
5	18	62	15	13,30	5	009100505
6	18	62	15	13,30	5	009100506
7	18	62	15	13,50	5	009100507
8	19	62	15	13,50	5	009100508
10	20	62	15	13,50	5	009100510
12	20	62	15	13,50	5	009100512



910ME/SB5	€	🔧	📦
4-5-6-8-10 mm	73,50	1	009100515

910PE/AS

chiavi a bussola maschio esagonale



"	Ø mm	L mm	L1 mm	€	🔧	📦
1/8	18,5	50	20	19,00	2	009100531
5/32	18,5	50	20	19,00	2	009100532
3/16	18,5	50	20	19,00	2	009100533
7/32	18,5	50	20	19,00	2	009100534
1/4	18,5	50	20	19,00	2	009100535
5/16	18,5	50	20	19,00	2	009100536
3/8	18,5	50	20	21,00	2	009100537

910PT

chiavi a bussola a giravite per viti con impronta pentalobata

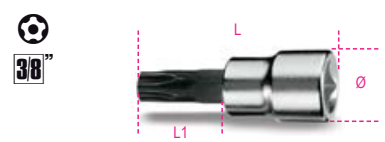

	Ø mm	L mm	L1 mm	€	🔧	📦
PT40	20	50	20	17,50	3	009100540
PT45	20	50	20	18,00	3	009100545
PT50	20	50	20	21,50	3	009100550



910PT/SB8	€	🔧	📦
PT10-PT15-PT20-PT25 PT30-PT40-PT45-PT50	143,00	1	009100558

910TX

chiavi a bussola maschio esagonale per viti con impronta Torx®



	Ø mm	L mm	L1 mm	€	🔧	📦
T15	18,5	50	20	14,50	5	009100519
T20	18,5	50	20	14,50	5	009100520
T25	18,5	50	20	14,50	5	009100521
T27	18,5	50	20	14,50	5	009100522
T30	18,5	50	20	14,50	5	009100523
T40	18,5	50	20	14,50	5	009100524
T45	18,5	50	20	14,50	3	009100525
T50	18,5	50	20	14,50	3	009100526



910TX/SB6	€	🔧	📦
T15-T20-T25 T27-T30-T40	94,50	1	009100530

910XZN

chiavi a bussola maschio a profilo XZN®



	L mm	€	🔧	📦
M4	50	15,50	3	009100559
M5	50	15,50	3	009100560
M6	50	15,50	3	009100561
M8	50	15,50	3	009100563
M10	50	16,50	3	009100565

910CF

chiavi a zampa di gallo

3/8"



mm	A mm	L mm	€		
10	21,3	32,3	9,40	2	009100135
11	23,1	34,3	9,40	2	009100136
12	25,5	36,2	10,60	2	009100137
13	26,9	37,4	10,60	2	009100138
14	30,2	40,0	11,20	2	009100139
15	33,3	41,3	11,70	2	009100140
16	33,3	41,3	12,70	2	009100141
17	38,1	46,5	14,80	2	009100142
18	38,1	46,5	14,80	2	009100143
19	39,6	48,0	16,00	2	009100144

3/8"



	€		
910CF/SB10 10-11-12-13-14-15 16-17-18-19 mm	132,50	1	009100147

910/15

raccordo con attacco quadro femmina 3/8" e maschio 1/4"

3/8"



UNI/ISO 3316 DIN 3123

L mm	Ø mm	□	■	€		
30	17,0	3/8	1/4	8,10	5	009100810



E' assolutamente necessario commisurare la coppia di serraggio alla capacità del quadro maschio per evitare rotture o danni accidentali

910/16

raccordo con attacco quadro femmina 3/8" e maschio 1/2"

3/8"



UNI/ISO 3316 DIN 3123

L mm	Ø mm	□	■	€		
32	18,0	3/8	1/2	8,50	5	009100814

Beta

Quality Tools

910/20 - 910/21 - 910/22

prolunghe con attacchi quadri maschio e femmina 3/8"

3/8"

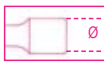

UNI/ISO 3316 DIN 3123

	L mm	Ø mm	€		
910/20	75	17	7,00	5	009100820
910/21	125	17	10,00	5	009100822
910/22	250	17	13,30	5	009100826

910AN

prolunghe con attacchi quadri maschio e femmina 3/8" angolari

3/8"

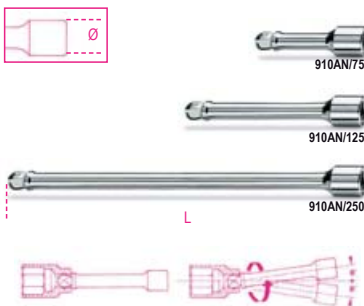

	L mm	Ø mm	€		
910AN/75	75	17	9,80	3	009100827
910AN/125	125	17	12,30	3	009100828
910AN/250	250	17	18,50	3	009100829

910/25

snodo con attacchi quadri maschio e femmina 3/8"

3/8"



UNI/ISO 3316 DIN 3123

L mm	Ø mm	€		
54,6	19	18,20	5	009100830

910M/35

quadro maschio 3/8" snodato con impugnatura in metallo

3/8"



UNI/ISO 3315 DIN 3122

L mm	€		
250	50,00	3	009100839

910/36A

quadro maschio 3/8" snodato con impugnatura

3/8"



UNI/ISO 3315 DIN 3122

L mm	L1 mm	€		
255	154	35,00	3	009100845

910/40

quadro maschio 3/8" snodato a T

3/8"



L mm	L1 mm	€		
420	175	38,00	3	009100850

910/42

quadro maschio 3/8" con spina scorrevole

3/8"



UNI/ISO 3315 DIN 3122

L mm	A mm	€		
210	30,5	11,90	5	009100854

910/46

quadro maschio 3/8" con manovella

3/8"



UNI/ISO 3315 DIN 3122

L mm	L1 mm	A mm	€		
315	80	115	23,50	1	009100862

910/55

cricchetto reversibile con attacco quadro maschio 3/8" meccanismo a 72 denti

72

3/8"



UNI/ISO 3315 DIN 3122

L mm	Ø mm	A mm	€		
200	30	33	43,00	3	009100882



910/55Q

cricchetto reversibile
con attacco quadro maschio 3/8"
meccanismo a 48 denti



UNI/ISO 3315 DIN 3122

L mm	Ø mm	A mm	€	Icon	Icon
200	30	33	43,00	3	009100885

**Meccanismi rotanti
di ricambio dei cricchetti,
vedi tabella dopo l'art. 929/C8**

910M/55

cricchetto reversibile
con attacco quadro maschio 3/8"
con impugnatura in metallo

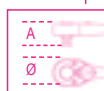

DIN 3122 - UNI ISO 3315

L mm	Ø mm	A mm	€	Icon	Icon
178	30	26	59,00	2	009100875

910M/56

cricchetto reversibile snodato
con attacco quadro maschio 3/8"
con impugnatura in metallo



L mm	Ø mm	A mm	€	Icon	Icon
265	31	29	80,00	2	009100887

910/58

cricchetto reversibile
con impugnatura rotante
con attacco quadro maschio 3/8"
meccanismo a 52 denti

- Pulsante di rilascio della bussola
- Sistema di inversione a ghiera sulla testa del cricchetto
- Impugnatura bimatériauale



L mm	Ø mm	A mm	€	Icon	Icon
222	37	38,5	66,00	1	009100884

910.../C10

10 chiavi a bussola
e 2 accessori



910A/C10 € 135,50 1 009100909

910A	6 - 7 - 8 - 10 - 11 - 12 13 - 14 - 17 - 19 mm
910/21	125 mm
910/55	
270x120x45 mm - 1,3 kg	

910B/C10 € 135,50 1 009100910

910B	6 - 7 - 8 - 10 - 11 - 12 13 - 14 - 17 - 19 mm
910/21	125 mm
910/55	
270x120x45 mm - 1,3 kg	

910A/C16...

16 chiavi a bussola esagonali
e 5 accessori



910A/C16 € 221,50 1 009100936

910A	6 - 7 - 8 - 9 - 10 - 11 - 12 - 13 14 - 15 - 16 - 17 - 18 - 19 21 - 22 mm
910/21	125 mm
910/22	250 mm
910/25	
910/42	
910/55	
335x145x60 mm - 2,3 kg	

910A/C16Q € 221,50 1 009100932

910A	6 - 7 - 8 - 9 - 10 - 11 - 12 - 13 14 - 15 - 16 - 17 - 18 - 19 21 - 22 mm
910/21	125 mm
910/22	250 mm
910/25	
910/42	
910/55Q	
335x145x60 mm - 2,3 kg	

910B/C16...

16 chiavi a bussola poligonali
e 5 accessori



910B/C16 € 221,50 1 009100937

910B	6 - 7 - 8 - 9 - 10 - 11 - 12 - 13 14 - 15 - 16 - 17 - 18 - 19 21 - 22 mm
910/21	125 mm
910/22	250 mm
910/25	
910/42	
910/55	
335x145x60 mm - 2,3 kg	

910B/C16Q € 221,50 1 009100933

910B	6 - 7 - 8 - 9 - 10 - 11 - 12 - 13 14 - 15 - 16 - 17 - 18 - 19 21 - 22 mm
910/21	125 mm
910/22	250 mm
910/25	
910/42	
910/55Q	
335x145x60 mm - 2,3 kg	

910A/C17

17 chiavi a bussola esagonali
e 9 accessori



910A/C17 € 328,00 1 009100938

910A	6 - 7 - 8 - 9 - 10 - 11 - 12 - 13 14 - 15 - 16 - 17 - 18 - 19 - 20 21 - 22 mm
910/15	□ 3/8 - ■ 1/4
910/16	□ 3/8 - ■ 1/2
910/21	125 mm
910/22	250 mm
910/25	
910/36A	
910/42	
910/46	
910/55	
420x280x60 mm - 4,0 kg	

910.../C29

17 chiavi a bussola
12 a giravite e 5 accessori

38



910A/C29 € 378,00 1 009100944

- 910A 6 - 7 - 8 - 9 - 10 - 11 - 12 - 13
14 - 15 - 16 - 17 - 18 - 19 - 20
21 - 22 mm
 - 910LP 1x5,5 - 1,2x6,5 - 1,2x8 mm
 - ⊕ 910PH PH1 - PH2 - PH3
 - 910PE 3 - 4 - 5 - 6 - 8 - 10 mm
 - 910/21 125 mm
 - 910/22 250 mm
 - 910/25
 - 910/42
 - 910/55
- 420x185x60 mm - 3,5 kg

910B/C29 € 378,00 1 009100945

- 910B 6 - 7 - 8 - 9 - 10 - 11 - 12 - 13
14 - 15 - 16 - 17 - 18 - 19 - 20
21 - 22 mm
 - 910LP 1x5,5 - 1,2x6,5 - 1,2x8 mm
 - ⊕ 910PH PH1 - PH2 - PH3
 - 910PE 3 - 4 - 5 - 6 - 8 - 10 mm
 - 910/21 125 mm
 - 910/22 250 mm
 - 910/25
 - 910/42
 - 910/55
- 420x185x60 mm - 3,5 kg

910AS/C13...

13 chiavi a bussola poligonali
e 5 accessori

38



910AS/C13 € 217,00 1 009100925

- 910AS 1/4 - 5/16 - 11/32 - 3/8 - 7/16
1/2 - 9/16 - 19/32 - 5/8 - 11/16
3/4 - 13/16 - 7/8
 - 910/21 125 mm
 - 910/22 250 mm
 - 910/42
 - 910/25
 - 910/55
- 335x145x60 mm - 2,3 kg

910AS/MBM-C18

13 chiavi a bussola poligonali
e 5 accessori
per manutenzioni aeronautiche

38



910AS/MBM-C18 € 233,00 1 009100926

- 910AS 1/4 - 5/16 - 11/32 - 3/8 - 7/16
1/2 - 9/16 - 19/32 - 5/8 - 11/16
3/4 - 13/16 - 7/8
 - 910/21 125 mm
 - 910/22 250 mm
 - 910/25
 - 910/42
 - 910M/55
- 335x145x60 mm - 2,5 kg

910A/C16HR

16 chiavi a bussola
esagonali e 5 accessori

• cricchetto con impugnatura rotante

38



910A/C16HR € 244,50 1 009100935

- 910A 6 - 7 - 8 - 9 - 10 - 11 - 12 - 13
14 - 15 - 16 - 17 - 18 - 19
21 - 22 mm
 - 910/21 125 mm
 - 910/22 250 mm
 - 910/25
 - 910/42 210 mm
 - 910/58
- 335x145x60 mm - 2,4 kg

920A

chiavi a bussola a mano
bocca esagonale

12



UNI/ISO 2725 DIN 3124

mm	Ø	L	Ø1	€	
8	12,4	38	21,7	5,55	10 009200008
9	13,5	38	21,7	5,55	10 009200009
10	14,9	38	21,7	5,55	10 009200010

mm	Ø	L	Ø1	€	
11	16,1	38	21,7	5,55	10 009200011
12	17,5	38	21,7	5,55	10 009200012
13	18,7	38	21,7	5,80	10 009200013
14	20,1	38	21,7	5,80	10 009200014
15	21,5	38	22,5	5,80	10 009200015
16	22,7	38	23,7	6,50	10 009200016
17	24,1	38	23,1	6,50	10 009200017
18	25,3	39	24,0	6,50	10 009200018
19	26,6	39	24,0	6,50	10 009200019
20	27,8	40	25,0	7,10	5 009200020
21	28,8	40	25,0	7,10	5 009200021
22	29,9	41	26,0	7,10	5 009200022
23	30,8	42	26,0	8,30	5 009200023
24	32,2	43	27,0	8,30	5 009200024
25	33,2	44	27,0	8,30	5 009200025
26	34,7	45	28,0	8,60	5 009200026
27	36,2	46	29,0	8,60	5 009200027
28	37,2	47	30,0	8,60	5 009200028
29	38,6	48	31,0	9,00	5 009200029
30	40,2	48	32,0	9,00	5 009200030
32	42,3	49	34,0	9,40	5 009200032

12



920A/SB13 € 95,00 1 009200040
10-11-12-13-14-15-16
17-18-19-20-21-22 mm

12



920A/SB8 € 78,50 1 009200042
23-24-25-26-27-28-30-32 mm

920MC

chiavi a bussola a mano
bocca esagonale
colorate

12



mm	Ø	L	Ø1	€	
8	13,2	38	22	6,10	5 009202008
10	15,3	38	22	6,10	5 009202010
11	16,5	38	22	6,10	5 009202011
12	17,8	38	22	6,10	5 009202012
13	19,0	38	22	6,30	5 009202013
14	20,3	38	22	6,30	5 009202014
15	21,6	38	22	6,30	5 009202015
16	23,0	38	23	7,10	5 009202016
17	23,9	38	24	7,10	5 009202017
18	25,0	38	25	7,10	5 009202018
19	26,5	38	24	7,10	5 009202019
21	28,8	38	27	7,80	3 009202021
22	29,9	40	28	7,80	3 009202022
24	32,8	40	30	9,10	3 009202024



920U

chiavi a bussola a mano
bocca multimpronta

12"



mm	"	Ø	Ø1	L	mm	€	12"	1	009201710
10	3/8	E12	M12	38	5,85	5	009201710		
11	7/16	E14	M14	38	5,85	5	009201711		
12	15/32	E16		38	5,85	5	009201712		
13	1/2	M16		38	6,10	5	009201713		
14	9/16	E18	M18	38	6,10	5	009201714		
15	19/32			38	6,10	5	009201715		
16	5/8	E20		38	6,85	5	009201716		
17				38	6,85	5	009201717		
18		E22		38	6,85	5	009201718		
19	3/4	E24		38	6,85	5	009201719		
20	25/32			38	7,50	3	009201720		
21				38	7,50	3	009201721		
22	7/8			38	7,50	3	009201722		
24	15/16			38	8,70	3	009201724		
27	1.1/16			42	9,00	3	009201727		
30	1.1/8			44	9,50	3	009201730		
32	1.1/4			44	9,90	3	009201732		

12"



920U/SB13
10-11-12-13-14-15-16
17-18-19-20-21-22 mm

€ 99,50 1 009201740

12"



920U/SB4
24-27-30-32 mm

€ 43,00 1 009201744

920FTX

chiavi a bussola a mano per viticon testa a profilo Torx®

12"



Ø	L	Ø1	€	12"	1	009200380
E10	13,2	36	21	9,00	5	009200380
E12	15,0	37	21	9,00	5	009200381
E14	16,3	37	21	9,00	5	009200382
E16	18,8	37	22	9,00	5	009200383
E18	20,4	37	22	9,00	5	009200384
E20	22,9	37	22	9,70	5	009200385
E22	25,0	37	24	11,30	3	009200387
E24	26,5	40	25	12,80	3	009200388

12"



920FTX/SB6
E10-E12-E14
E16-E18-E20

€ 62,00 1 009200390



12"



920FTX/C8
E10-E12-E14-E16
E18-E20-E22-E24
270X120X45 mm - 1 kg

€ 104,00 1 009200391

920FTX/L

chiavi a bussola a mano lunghe
per viti con testa a profilo Torx®

12"



Ø	L	Ø1	€	12"	1	009200400
E10	13,2	77	21,0	18,90	5	009200400
E12	15,0	77	21,0	18,90	5	009200401
E14	16,3	77	21,0	18,90	5	009200402
E16	18,8	77	21,8	18,90	3	009200403
E18	20,4	77	21,8	18,90	3	009200404
E20	22,9	77	22,0	18,90	3	009200405

12"



920FTX-LSB6
E10-E12-E14
E16-E18-E20

€ 121,00 1 009200409

920LP

chiavi a bussola a giravite
per viti con intaglio

12"



SxA	Ø	L	L1	€	12"	1	009200452
1x5,5	22,5	62	24	14,70	3	009200452	
1,2x6,5	22,5	62	24	14,70	3	009200453	
1,2x8	22,5	62	24	14,70	3	009200454	
1,6x9	22,5	62	24	14,70	3	009200456	
2x12	22,5	62	24	14,70	3	009200458	

920PH

chiavi a bussola a giravite
per viti con impronta a croce Phillips®

12"



PH	Ø	L	L1	€	12"	1	009200471
1	22,5	56	18	12,90	3	009200471	
2	22,5	56	18	12,90	3	009200472	
3	22,5	56	18	12,90	3	009200473	
4	22,5	56	18	12,90	3	009200474	

+

12"



920PH/SB4
PH1-PH2-PH3-PH4

€ 57,50 1 009200479

920LH/SB7

chiavi a bussola a giravite
per viti con impronta a croce Phillips®

+

12"



920LH/SB7

€ 106,00 1 009200478

920LP 1,2x6,5 - 1,2x8
920PH 1,6x9 - 2x12 mm
PH2 - PH3 - PH4

920PE

chiavi a bussola
maschio esagonale

+

12"



DIN 7422

mm	Ø	L	L1	€	12"	1	009200410
3	22,5	58	20	11,70	5	009200410	
4	22,5	58	20	11,70	5	009200412	
5	22,5	58	20	11,70	5	009200414	
5L	22,5	100	62	12,80	5	009200415	
6	22,5	58	20	11,70	5	009200417	
6L	22,5	100	62	12,80	5	009200418	
7	22,5	58	20	11,70	5	009200420	
7L	22,5	100	62	12,80	5	009200421	
8	22,5	58	20	11,70	5	009200423	
8L	22,5	100	62	12,80	5	009200424	
9	22,5	58	20	11,70	5	009200425	
9L	22,5	140	102	13,50	5	009200426	
10	22,5	58	20	11,70	5	009200428	
10L	22,5	140	102	13,50	5	009200429	
12	23,0	58	20	13,70	5	009200432	
12L	22,5	140	102	15,50	5	009200433	
14	23,0	58	20	13,70	5	009200434	
14L	22,5	140	102	15,50	5	009200435	
17	29,5	60	22	16,70	5	009200437	
19	29,5	60	22	16,70	5	009200439	

+

12"



920PE/SB9

4-5-6-8-10 mm
5L-6L-8L-10L mm

€ 120,50 1 009200441

12"



920PE/C10 € 156,00 1 009200443
 4-5-6-7-8-10
 12-14-17-19 mm
 ≡ 270X120X45 mm - 1,5 kg

920PE/AS
 chiavi a bussola
 maschio esagonale

12"



"	Ø mm	L mm	L1 mm	€		
1/8	22,5	58	20	13,80	2	009200460
3/16	22,5	58	20	13,80	2	009200461
1/4	22,5	58	20	13,80	2	009200463
3/8	22,5	58	20	13,80	2	009200464
1/2	22,5	60	20	15,00	2	009200465
3/4	22,5	60	20	16,00	1	009200468

12"



920PE-AS/SB6 € 93,50 1 009200469
 1/8-3/16-1/4-3/8-1/2-3/4

920BP
 chiavi a bussola maschio esagonale
 con estremità sferica

12"

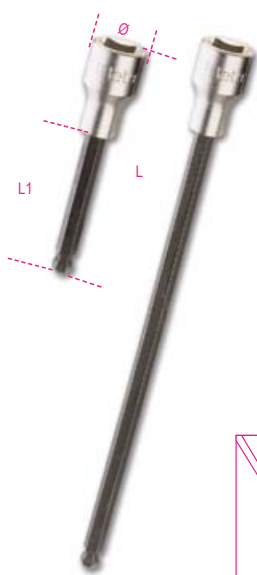

mm	Ø mm	L mm	L1 mm	€		
5L	22,5	100	62	14,80	5	009200490
5XL	22,5	240	202	19,00	1	009200495
6L	22,5	100	62	14,80	5	009200491
6XL	22,5	240	202	19,00	1	009200496
7L	22,5	100	62	14,80	5	009200492
8L	22,5	100	62	14,80	5	009200493
8XL	22,5	240	202	19,00	1	009200497
10L	22,5	140	102	16,00	5	009200494

12"



920BP/SB8 € 141,50 1 009200500
 5L-6L-7L-8L-10L mm
 5XL-6XL-8XL mm

920ME
 chiavi a bussola
 maschio esagonale

12"



mm	Ø mm	L mm	L1 mm	€		
5	21	75	15,5	13,80	5	009200505
6	21	75	15,5	13,80	5	009200506
7	21	75	15,5	13,80	5	009200507
8	21	75	15,5	13,80	5	009200508
10	23	75	15,5	14,40	5	009200510
12	24	75	15,5	16,50	5	009200512
14	24	75	15,5	17,00	5	009200514
17	24	75	15,5	17,00	5	009200517

12"



920ME/SB7 € 114,50 1 009200519
 5-6-8-10-12-14-17 mm

12"



920ME/C7 € 133,50 1 009200518
 5-6-8-10-12-14-17 mm
 ≡ 250X100X35 mm - 1,4 kg

920TX
 chiavi a bussola maschio
 per viti con impronta Torx®

12"



mm	Ø mm	L mm	L1 mm	€		
T20	22,5	58	20	14,40	5	009200520
T20L	22,5	120	82	18,40	3	009200530
T25	22,5	58	20	14,40	5	009200521
T25L	22,5	120	82	18,40	3	009200531
T27	22,5	58	20	14,40	5	009200522
T27L	22,5	120	82	18,40	3	009200533

mm	Ø mm	L mm	L1 mm	€		
T30	22,5	58	20	14,40	5	009200523
T30L	22,5	120	82	18,40	3	009200534
T40	22,5	58	20	14,40	5	009200524
T40L	22,5	120	82	18,40	3	009200535
T45	22,5	58	20	14,40	5	009200525
T45L	22,5	120	82	18,40	3	009200537
T50	22,5	58	20	14,40	5	009200526
T50L	23,0	140	102	18,40	3	009200538
T55	23,0	58	20	19,20	3	009200527
T55L	23,0	140	102	26,00	3	009200539
T60	23,0	58	20	19,20	3	009200528
T60L	23,0	140	102	26,00	3	009200540
T70L	23,0	120	82	26,00	3	009200541

12"



920TX-SB9 € 149,00 1 009200532
 T20-T25-T27-T30
 T40-T45-T50-T55-T60

12"



920TX-L/SB10 € 218,00 1 009200545
 T20L-T25L-T27L-T30L-T40L-
 T45L-T50L-T55L-T60L-T70L

12"



920TX/C9 € 164,00 1 009200546
 T20-T25-T27-T30-T40
 T45-T50-T55-T60
 ≡ 270X120X45 mm - 1,2 kg

920RTX
 chiavi a bussola maschio per viti
 con impronta Tamper Resistant Torx®

12"



mm	Ø mm	L mm	L1 mm	€		
T20	22,5	58	20	15,30	5	009200370
T25	22,5	58	20	15,30	5	009200371
T27	22,5	58	20	15,30	5	009200372
T30	22,5	58	20	15,30	5	009200373
T40	22,5	58	20	15,30	5	009200374

12"



920RTX/SB5 € 83,00 1 009200378
 T20-T25-T27-T30-T40

920XZN

chiavi a bussola maschio a profilo XZN®

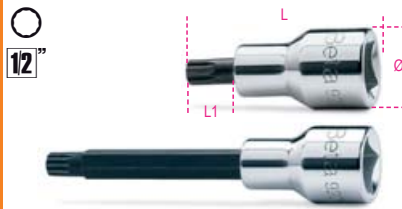

DIN 2324

	Ø	L	L1	€		
	mm	mm	mm			
M4	22,5	58	20	15,40	3	009200559
M5	22,5	58	20	15,40	3	009200560
M6	22,5	58	20	15,40	3	009200561
M6L	22,5	100	62	17,50	3	009200562
M8	22,5	58	20	15,40	3	009200563
M8L	22,5	100	62	17,50	3	009200564
M9	22,5	58	20	15,40	3	009200582
M9L	22,5	100	62	17,50	3	009200583
M10	22,5	58	20	15,50	3	009200565
M10L	22,5	100	62	17,50	3	009200566
M12	22,5	58	20	16,00	3	009200568
M12L	22,5	100	62	18,00	3	009200569
M14	23,0	58	20	16,00	3	009200571
M14L	23,0	100	62	18,00	3	009200572
M16	23,0	58	20	20,00	3	009200573
M18	23,0	58	20	20,50	3	009200574



920XZN/SB7 € 117,50 1 009200579
M4-M5-M6-M8
M10-M12-M14



920XZN/SB12 € 215,00 1 009200577
M5-M6-M8-M10-M12
M14-M16-M6L-M8L
M10L-M12L-M14L



920XZN-L/S5 € 88,50 1 009200578
M6L-M8L-M10L
M12L-M14L

920ES

chiavi a bussola per viti con impronta esascalanata



UNI 9326

Ø		L	L1	€		
mm		mm	mm			
7	(6R)	58	20	21,50	5	009200587
7XL	(6R)	240	202	30,50	1	009200607
9	(8R)	58	20	21,50	5	009200589
9XL	(8R)	240	202	30,50	1	009200609
10	(8S)	58	20	21,50	5	009200590
10XL	(8S)	240	202	30,50	1	009200610
11	(10R)	58	20	21,50	5	009200591
11XL	(10R)	240	202	30,50	1	009200611
12L	(10S)	100	62	24,00	3	009200592
12XL	(10S)	240	202	33,00	1	009200612
14L	(12S)	100	62	24,00	3	009200594
14XL	(12S)	240	202	33,00	1	009200614
16L	(14R)	100	62	24,00	3	009200596
16XL	(14R)	240	202	33,00	1	009200616



920ES/SB7 € 166,50 1 009200598
7-9-10-11-12L-14L-16L



920ES-XL/SB7 € 229,50 1 009200618
7XL-9XL-10XL-11XL
12XL-14XL-16XL

920/15

raccordo con attacco quadro femmina 1/2" e maschio 3/8"



UNI/ISO 3316 DIN 3123

L	□	■	Ø	€		
mm			mm			
42	1/2	3/8	22,0	9,20	5	009200810



E' assolutamente necessario commisurare la coppia di serraggio alla capacità del quadro maschio per evitare rotture o danni accidentali

920/16

raccordo con attacco quadro femmina 1/2" e maschio 3/4"



UNI/ISO 3316 DIN 3123

L	□	■	Ø	€		
mm			mm			
46	1/2	3/4	26	12,00	5	009200814

920/20÷920/23

prolunghe con attacchi quadri maschio e femmina 1/2"

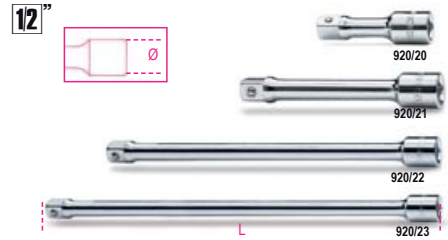

UNI/ISO 3316 DIN 3123

	L	Ø	€		
	mm	mm			
920/20	75	22	11,20	5	009200818
920/21	125	22	13,80	5	009200822
920/22	255	22	15,50	5	009200826
920/23	375	22	20,80	2	009200827

920AN

prolunghe con attacchi quadri maschio e femmina 1/2" angolari

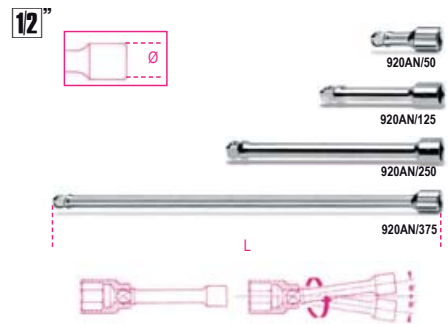

	L	Ø	€		
	mm	mm			
920AN/50	50	22	12,00	5	009200833
920AN/125	125	22	16,60	5	009200834
920AN/250	250	22	23,50	3	009200835
920AN/375	375	22	31,50	3	009200836

920/25

snodo con attacchi quadri maschio e femmina 1/2"



UNI/ISO 3316 DIN 3123

L	Ø	€		
mm	mm			
75	27	22,00	5	009200830

920/35A

quadro maschio 1/2" snodato con impugnatura



UNI/ISO 3315 DIN 3122

L	L1	€		
mm	mm			
285	160	44,00	3	009200846



920M/35

quadro maschio 1/2" snodato
con impugnatura in metallo

12"



UNI/ISO 3315 DIN 3122

L
mm
380 € 62,50 2 009200845

920M/35L

quadro maschio 1/2" snodato
con impugnatura in metallo, lungo

12"



L
mm
600 € 95,00 1 009200843



È assolutamente necessario applicare
il carico di torsione adeguatamente
e progressivamente per evitare rotture
o danni accidentali.

920/36A

quadro maschio 1/2" snodato
con impugnatura

12"



UNI/ISO 3315 DIN 3122

L L1
mm mm
408 283 € 49,50 2 009200847

920/38

quadro maschio estensibile 1/2" snodato
con impugnatura

12"



L L max
mm mm
262 402 € 74,50 1 009200839

920/40

quadro maschio 1/2"
snodato a T

12"



L L1
mm mm
490 230 € 51,00 2 009200850

920/42

quadro maschio 1/2"
con spina scorrevole

12"

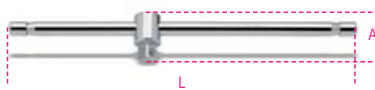

UNI/ISO 3315 DIN 3122

L A
mm mm
305 42 € 15,40 5 009200854

920/44

quadro maschio 1/2"
ad angolo

12"



UNI/ISO 3315 DIN 3122

L L1
mm mm
230 60 € 23,00 3 009200858

920/46

quadro maschio 1/2"
con manovella

12"



UNI/ISO 3315 DIN 3122

L L1 A
mm mm mm
385 110 160 € 28,50 1 009200862

920/50

cricchetto semplice
con attacco quadro scorrevole 1/2"
meccanismo a 72 denti

12"



UNI/ISO 3315 DIN 3122

L Ø A
mm mm mm
275 40 42 € 49,00 3 009200871

920/50F

cricchetto semplice
con attacco quadro femmina 1/2"
meccanismo a 72 denti

12"



UNI/ISO 3315 DIN 3122

L Ø A
mm mm mm
275 40 27 € 45,50 2 009200889

920/55

cricchetto reversibile
con attacco quadro maschio 1/2"
meccanismo a 72 denti

12"



UNI/ISO 3315 DIN 3122

L Ø A
mm mm mm
275 40 43 € 52,00 3 009200882

920/55Q

cricchetto reversibile
con attacco quadro maschio 1/2"
meccanismo a 48 denti

12"



UNI/ISO 3315 DIN 3122

L Ø A
mm mm mm
275 40 43 € 52,00 3 009200885

920/55X

cricchetto reversibile
con attacco quadro maschio 1/2"
meccanismo a 72 denti

12"



UNI/ISO 3315 DIN 3122

L Ø A
mm mm mm
200 30 33 € 45,00 3 009200895

920/55LC

cricchetto reversibile
con attacco quadro maschio 1/2"
"Locking System"
meccanismo a 72 denti

12"



UNI/ISO 3315 DIN 3122

L Ø A
mm mm mm
275 40 43 € 60,50 2 009200896

920/55L

cricchetto estensibile reversibile
con attacco quadro maschio 1/2"
meccanismo a 72 denti



L mm	L max mm	Ø mm	A mm	€	1	009200927
282	422	40	43	91,00		

920M/55

cricchetto reversibile
con attacco quadro maschio 1/2"
con impugnatura in metallo



L mm	Ø mm	A mm	€	1	009200893
253	38	35	67,50		

920/56A

cricchetto reversibile snodato
con attacco quadro maschio 1/2"
meccanismo a 72 denti



L mm	Ø mm	A mm	€	1	009200911
315	40	43	86,00		

920M/56

cricchetto reversibile snodato
con attacco quadro maschio 1/2"
con impugnatura in metallo



L mm	Ø mm	A mm	€	2	009200894
330	38	35,7	89,00		



920/58

cricchetto reversibile
con impugnatura rotante
con attacco quadro maschio 1/2"
meccanismo a 52 denti

- Pulsante di rilascio della bussola
- Sistema di inversione a ghiera sulla testa del cricchetto
- Impugnatura bimatériale

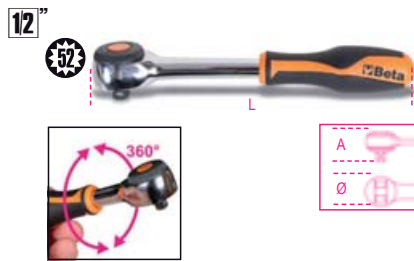

L mm	Ø mm	A mm	€	1	009200926
281	42,5	45	78,50		

**Meccanismi rotanti
di ricambio dei cricchetti,
vedi tabella dopo l'art. 929/C8**

920.../C11

11 chiavi a bussola
e 2 accessori



920A/C11	€	1	009200921
	163,00		

Ø 920A	10 - 12 - 13 - 14 - 15 - 16 17 - 18 - 19 - 21 - 22 mm
920/22	255 mm
920/50	
335x145x60 mm - 2,5 kg	

920B/C11	€	1	009200922
	163,00		

Ø 920B	10 - 12 - 13 - 14 - 15 - 16 17 - 18 - 19 - 21 - 22 mm
920/22	255 mm
920/50	
335x145x60 mm - 2,5 kg	

920.../C12...

12 chiavi a bussola
e 5 accessori



920A/C12X	€	1	009200933
	237,50		

Ø 920A	10 - 11 - 12 - 13 - 14 - 17 - 19 22 - 24 - 27 - 30 - 32 mm
920/21	125 mm
920/22	255 mm
920/25	
920/42	
920/55	
420x185x60 mm - 4,2 kg	

920A/C12	€	1	009200931
	234,50		

Ø 920A	10 - 11 - 12 - 13 - 14 - 17 - 19 22 - 24 - 27 - 30 - 32 mm
920/21	125 mm
920/22	255 mm
920/25	
920/42	
920/50	
420x185x60 mm - 4,2 kg	

920B/C12X	€	1	009200934
	237,50		

Ø 920B	10 - 11 - 12 - 13 - 14 - 17 - 19 22 - 24 - 27 - 30 - 32 mm
920/21	125 mm
920/22	255 mm
920/25	
920/42	
920/55	
420x185x60 mm - 4,0 kg	

920B/C12	€	1	009200932
	234,50		

Ø 920B	10 - 11 - 12 - 13 - 14 - 17 - 19 22 - 24 - 27 - 30 - 32 mm
920/21	125 mm
920/22	255 mm
920/25	
920/42	
920/50	
420x185x60 mm - 4,0 kg	

920MC/C14

14 chiavi a bussola esagonali colorate e 5 accessori

12"



920MC/C14 € 250,00 1 009202964

	920MC	8 - 10 - 11 - 12 - 13 - 14 - 15 - 16 - 17 - 18 - 19 - 21 - 22 - 24 mm
	920/21	125 mm
	920/22	255 mm
	920/25	
	920/42	
	920/55	
≡ 420x185x60 mm - 4,2 kg		

920.../C20...

20 chiavi a bussola e 5 accessori

12"



920A/C20X € 296,00 1 009200950

	920A	10 - 11 - 12 - 13 - 14 - 15 - 16 - 17 - 18 - 19 - 20 - 21 - 22 - 23 - 24 - 26 - 27 - 28 - 30 - 32 mm
	920/21	125 mm
	920/22	255 mm
	920/25	
	920/42	
	920/55	
≡ 420x185x60 mm - 5,1 kg		

920A/C20 € 293,00 1 009200948

	920A	10 - 11 - 12 - 13 - 14 - 15 - 16 - 17 - 18 - 19 - 20 - 21 - 22 - 23 - 24 - 26 - 27 - 28 - 30 - 32 mm
	920/21	125 mm
	920/22	255 mm
	920/25	
	920/42	
	920/50	
≡ 420x185x60 mm - 5,1 kg		

920A/C20Q € 296,00 1 009200955

	920A	10 - 11 - 12 - 13 - 14 - 15 - 16 - 17 - 18 - 19 - 20 - 21 - 22 - 23 - 24 - 26 - 27 - 28 - 30 - 32 mm
	920/21	125 mm
	920/22	255 mm
	920/25	
	920/42	
	920/55Q	
≡ 420x185x60 mm - 5,1 kg		

920B/C20 € 293,00 1 009200949

	920B	10 - 11 - 12 - 13 - 14 - 15 - 16 - 17 - 18 - 19 - 20 - 21 - 22 - 23 - 24 - 26 - 27 - 28 - 30 - 32 mm
	920/21	125 mm
	920/22	255 mm
	920/25	
	920/42	
	920/50	
≡ 420x185x60 mm - 5,0 kg		

920B/C20X € 296,00 1 009200951

	920B	10 - 11 - 12 - 13 - 14 - 15 - 16 - 17 - 18 - 19 - 20 - 21 - 22 - 23 - 24 - 26 - 27 - 28 - 30 - 32 mm
	920/21	125 mm
	920/22	255 mm
	920/25	
	920/42	
	920/55	
≡ 420x185x60 mm - 5,0 kg		

920.../C21...

21 chiavi a bussola e 6 accessori

12"



920A/C21 € 340,00 1 009200952

	920A	10 - 11 - 12 - 13 - 14 - 15 - 16 - 17 - 18 - 19 - 20 - 21 - 22 - 23 - 24 - 25 - 26 - 27 - 28 - 30 - 32 mm
	920/21	125 mm
	920/22	255 mm
	920/25	
	920/42	
	920/46	
	920/50	
≡ 420x280x60 mm - 6,5 kg		

920A/C21X € 343,00 1 009200983

	920A	10 - 11 - 12 - 13 - 14 - 15 - 16 - 17 - 18 - 19 - 20 - 21 - 22 - 23 - 24 - 25 - 26 - 27 - 28 - 30 - 32 mm
	920/21	125 mm
	920/22	255 mm
	920/25	
	920/42	
	920/46	
	920/55	
≡ 420x280x60 mm - 6,4 kg		

920B/C21 € 340,00 1 009200953

	920B	10 - 11 - 12 - 13 - 14 - 15 - 16 - 17 - 18 - 19 - 20 - 21 - 22 - 23 - 24 - 25 - 26 - 27 - 28 - 30 - 32 mm
	920/21	125 mm
	920/22	255 mm
	920/25	
	920/42	
	920/46	
	920/50	
≡ 420x280x60 mm - 6,4 kg		

920B/C21X € 343,00 1 009200984

	920B	10 - 11 - 12 - 13 - 14 - 15 - 16 - 17 - 18 - 19 - 20 - 21 - 22 - 23 - 24 - 25 - 26 - 27 - 28 - 30 - 32 mm
	920/21	125 mm
	920/22	255 mm
	920/25	
	920/42	
	920/46	
	920/55	
≡ 420x280x60 mm - 6,4 kg		



920B/C30Q

30 chiavi a bussola poligonali
e 5 accessori

12"



920B/C30Q € 475,00 1 009200986

- 920B 10 - 11 - 12 - 13 - 14 - 15 - 16
17 - 18 - 19 - 20 - 21 - 22 - 23
24 - 26 - 27 - 28 - 30 - 32 mm
 - 920LP 1,2x8 - 1,6x9 - 2x12 mm
 - ⊕ 920PH PH2 - PH3 - PH4
 - 920PE 4 - 5 - 6 - 8 - 10 - 12 - 14 mm
 - 920/21 125 mm
 - 920/22 255 mm
 - 920/25
 - 920/42
 - ⊕ 920/55
- 420x280x60 mm - 6,7 kg

920.../C33

20 chiavi a bussola
13 a giravite e 5 accessori

12"



920A/C33 € 475,00 1 009200985

- 920A 10 - 11 - 12 - 13 - 14 - 15 - 16
17 - 18 - 19 - 20 - 21 - 22 - 23
24 - 26 - 27 - 28 - 30 - 32 mm
 - 920LP 1,2x8 - 1,6x9 - 2x12 mm
 - ⊕ 920PH PH2 - PH3 - PH4
 - 920PE 4 - 5 - 6 - 8 - 10 - 12 - 14 mm
 - 920/21 125 mm
 - 920/22 255 mm
 - 920/25
 - 920/42
 - ⊕ 920/55
- 420x280x60 mm - 6,7 kg

920B/C33 € 475,00 1 009200986

- 920B 10 - 11 - 12 - 13 - 14 - 15 - 16
17 - 18 - 19 - 20 - 21 - 22 - 23
24 - 26 - 27 - 28 - 30 - 32 mm
 - 920LP 1,2x8 - 1,6x9 - 2x12 mm
 - ⊕ 920PH PH2 - PH3 - PH4
 - 920PE 4 - 5 - 6 - 8 - 10 - 12 - 14 mm
 - 920/21 125 mm
 - 920/22 255 mm
 - 920/25
 - 920/42
 - ⊕ 920/55
- 420x280x60 mm - 6,7 kg

920/C37

37 chiavi a bussola poligonali
e 5 accessori

12"



920/C37 € 447,00 1 009200988

- 920B 10 - 11 - 12 - 13 - 14 - 15 - 16
17 - 18 - 19 - 20 - 21 - 22 - 23
24 - 26 - 27 - 28 - 30 - 32 mm
 - 920AS 3/8 - 7/16 - 1/2 - 9/16 - 19/32
5/8 - 11/16 - 3/4 - 25/32 - 13/16
7/8 - 15/16 - 1 - 1.1/16 - 1.1/8
1.3/16 - 1.1/4
 - 920/21 125 mm
 - 920/22 255 mm
 - 920/25
 - 920/42
 - ⊕ 920/55
- 420x280x60 mm - 7,5 kg

920AS/C10

10 chiavi a bussola poligonali
e 2 accessori

12"



920AS/C10 € 169,50 1 009200919

- 920AS 3/8 - 7/16 - 1/2 - 9/16 - 5/8
11/16 - 3/4 - 13/16 - 7/8 - 15/16
 - 920/22 255 mm
 - ⊕ 920/50
- 335x145x60 mm - 2,6 kg

920AS/C15

15 chiavi a bussola poligonali
e 6 accessori

12"



920AS/C15 € 315,00 1 009200947

- 920AS 3/8 - 7/16 - 1/2 - 9/16 - 5/8 - 11/16
3/4 - 13/16 - 7/8 - 15/16 - 1
1.1/16 - 1.1/8 - 1.3/16 - 1.1/4
 - 920/21 125 mm
 - 920/22 255 mm
 - 920/25
 - 920/42
 - 920/46
 - ⊕ 920/50
- 420x280x60 mm - 5,9 kg



920AS/C17X

17 chiavi a bussola poligonali
e 5 accessori

12"



920AS/C17X € 295,00 1 009200942

	920AS	3/8 - 7/16 - 1/2 - 9/16 - 19/32 - 5/8 11/16 - 3/4 - 25/32 - 13/16 - 7/8 15/16 - 1 - 1.1/16 - 1.1/8 - 1.3/16 - 1.1/4
	920/21	125 mm
	920/22	255 mm
	920/25	
	920/42	
	920/55	

420x185x60 mm - 4,8 kg

920AS/MBM-C21

16 chiavi a bussola poligonali
e 5 accessori
per manutenzioni aeronautiche

12"



920AS/MBM-C21 € 300,00 1 009200944

	920AS	3/8 - 7/16 - 1/2 - 9/16 19/32 - 5/8 - 11/16 - 3/4 25/32 - 13/16 - 7/8 - 15/16 1 - 1.1/16 - 1.3/16 - 1.1/4
	920M/55	
	920/21	125 mm
	920/22	255 mm
	920/25	
	920/42	

420x185x60 mm - 5,0 kg

920TX/C17

6 inserti per avvitatori
6 chiavi a bussola
5 chiavi a bussola maschio
e 4 accessori, per viti con impronta Torx®



12"



920TX/C17 € 271,00 1 009200989

	861TX	T8 - T10 - T15 - T20 - T25 - T27
	897	
	920TX	T27 - T30 - T40 - T45 - T50
	920FTX	E10 - E12 - E14 - E16 - E18 - E20
	920/20	75 mm
	920/22	255 mm
	920/55	

420x185x60 mm - 2,9 kg

920A/C17HR

17 chiavi a bussola esagonali e 5 accessori
in termoformato rigido, in cassetta di lamiera

• cricchetto con impugnatura rotante

12"



920A/C17HR € 297,00 1 009200939

	920A	10-11-12-13-14-15-16-17-18-19-20- 21-22-24-27-30-32 mm
	920/21	125 mm
	920/22	255 mm
	920/25	
	920/42	
	920/58	

420x185x60 mm - 5,1 kg

928A

chiavi a bussola a mano
bocca esagonale



UNI/ISO 2725
DIN 3124

mm	Ø mm	L mm	Ø1 mm	€		
19	29,2	50	34	14,30	5	009280019
21	30,0	51	34	14,50	5	009280021
22	31,3	53	34	14,50	5	009280022
23	33,3	53	34	14,80	5	009280023
24	34,5	53	34	15,00	5	009280024
26	36,8	55	35	16,00	5	009280026
27	38,0	56	35	16,00	5	009280027
28	39,0	57	35	17,00	3	009280028
29	40,2	58	35	17,30	3	009280029
30	41,5	58	37	17,80	3	009280030
32	44,3	60	37	18,80	3	009280032
33	45,8	60	37	19,80	3	009280033
34	46,8	60	37	20,00	3	009280034
35	48,1	62	38	20,30	3	009280035
36	49,5	64	38	20,30	3	009280036
38	52,0	68	40	22,30	3	009280038
41	56,0	71	40	24,80	3	009280041
46	62,3	75	43	31,00	3	009280046
50	67,4	80	43	36,50	3	009280050
55	73,7	84	48	45,50	1	009280055
60	80,0	87	48	52,00	1	009280060

928B

chiavi a bussola a mano
bocca poligonale



UNI/ISO 2725
DIN 3124

mm	Ø mm	L mm	Ø1 mm	€		
19	29,2	50	34	14,30	5	009280119
21	30,0	51	34	14,50	5	009280121
22	31,3	53	34	14,50	5	009280122
23	33,3	53	34	14,80	5	009280123
24	34,5	53	34	15,00	5	009280124
26	36,8	55	35	16,00	5	009280126
27	38,0	56	35	16,00	5	009280127
28	39,0	57	35	17,00	3	009280128
29	40,2	58	35	17,30	3	009280129
30	41,5	58	37	17,80	3	009280130
32	44,3	60	37	18,80	3	009280132
33	45,8	60	37	19,80	3	009280133
34	46,8	60	37	20,00	3	009280134
35	48,1	62	38	20,30	3	009280135
36	49,5	64	38	20,30	3	009280136
38	52,0	68	40	22,30	3	009280138
41	56,0	71	40	24,80	3	009280141
46	62,3	75	43	31,00	3	009280146
50	67,4	80	43	36,50	3	009280150
55	73,7	84	48	45,50	1	009280155
60	80,0	87	48	52,00	1	009280160

928AS

chiavi a bussola a mano
bocca esagonale



"	Ø mm	L mm	Ø1 mm	€		
7/8	32,0	53	34	16,00	1	009280202
15/16	34,5	53	34	16,00	1	009280203
1	36,2	55	35	17,00	1	009280204
1.1/16	38,0	56	35	17,50	1	009280205
1.1/8	40,2	58	35	18,00	1	009280206
1.1/4	44,2	60	37	19,50	1	009280208
1.5/16	45,8	60	37	20,50	1	009280209
1.3/8	48,1	62	38	21,50	1	009280210
1.7/16	49,5	64	38	22,50	1	009280211
1.1/2	52,0	68	40	24,00	1	009280212
1.5/8	56,0	71	40	26,50	1	009280214
1.11/16	58,8	74	40	30,50	1	009280215
1.13/16	62,3	75	43	34,00	1	009280217
1.7/8	65,0	78	43	36,50	1	009280218
2	68,3	80	43	42,00	1	009280219
2.1/16	71,5	83	48	49,00	1	009280220

928ME

chiavi a bussola
maschio esagonale



mm	Ø mm	L mm	L1 mm	€		
14	35	75	15,5	32,50	2	009280514
17	35	75	15,5	32,50	2	009280517
19	35	75	15,5	32,50	2	009280519
22	35	75	22,5	32,50	2	009280522

928/15

raccordo con attacco quadro
femmina 3/4" e maschio 1/2"



UNI/ISO 3316
DIN 3123

L mm	Ø mm	□	■	€		
51,5	34	3/4	1/2	17,00	5	009280801



E' assolutamente necessario commisurare la coppia di serraggio alla capacità del quadro maschio per evitare rotture o danni accidentali

928/16

raccordo con attacco quadro
femmina 3/4" e maschio 1"



UNI/ISO 3316
DIN 3123

L mm	Ø mm	□	■	€		
65	34	3/4	1"	20,50	5	009280807

928/20 - 928/21 - 928/22

prolunghe con attacchi quadri
maschio e femmina 3/4"

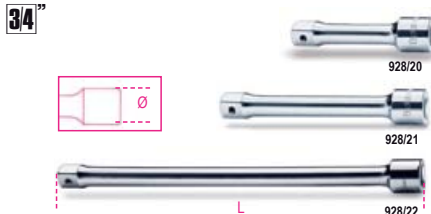

UNI/ISO 3316
DIN 3123

	L mm	Ø mm	€		
928/20	100	34	20,00	3	009280810
928/21	200	34	27,00	3	009280815
928/22	380	34	39,50	3	009280825

928/25

snodo con attacchi quadri maschio
e femmina 3/4"



UNI/ISO 3316 DIN 3123

L mm	Ø mm	€		
108	40	68,00	1	009280830

928/36A

quadro maschio 3/4" snodato
con impugnatura



DIN 3122 - UNI ISO 3315

L mm	€		
545	81,00	1	009280844

928/42

quadro maschio 3/4"
con spina scorrevole

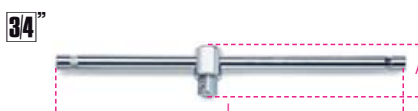

UNI/ISO 3315 DIN 3122

L mm	A mm	€		
450	62,5	43,00	3	009280850

928/55

cricchetto reversibile
con attacco quadro maschio 3/4"
meccanismo a 72 denti



DIN 3122 - UNI ISO 3315

L mm	Ø mm	A mm	€		
510	58	59	138,00	2	009280862

Meccanismi rotanti
di ricambio dei cricchetti,
vedi tabella dopo l'art. 929/C8

928.../C12

12 chiavi a bussola esagonali e 5 accessori in
cassetta di lamiera



928A/C12 € 712,00 1 009280955

928A	22 - 24 - 27 - 30 - 32 - 34 - 36 38 - 41 - 46 - 50 - 55 mm
928/21	200 mm
928/22	380 mm
928/25	
928/42	
928/55	

530x220x80 mm - 13,5 kg

928B/C12 € 712,00 1 009280957

928B	22 - 24 - 27 - 30 - 32 - 34 - 36 38 - 41 - 46 - 50 - 55 mm
928/21	200 mm
928/22	380 mm
928/25	
928/42	
928/55	

530x220x80 mm - 13,5 kg

Beta
Quality Tools

928AS/C12

12 chiavi a bussola esagonali e 5 accessori in cassetta di lamiera



928AS/C12 € 733,00 1 009280968

928AS	7/8-15/16-1.1/16-1.1/8-1.1/4 1.5/16-1.7/16-1.1/2-1.11/16 1.13/16-1.7/8-2.1/16
928/21	200 mm
928/22	380 mm
928/25	
928/42	
928/55	

530x220x80 mm - 13,5 kg

929

chiavi a bussola a mano bocca esagonale



UNI/ISO 2725 DIN 3124

Ø mm	Ø mm	L mm	Ø1 mm	€		
36	51	65	48	30,00	1	009290036
41	57	70	48	32,00	1	009290041
46	65	75	48	35,00	1	009290046
50	70	80	48	41,00	1	009290050
55	76	85	54	48,00	1	009290055
60	82	90	54	51,00	1	009290060
65	88	95	54	66,00	1	009290065
70	92	100	60	79,00	1	009290070
75	99	110	60	86,00	1	009290075
80	106	120	60	98,00	1	009290080

929/15

raccordo con attacco quadro femmina 1" e maschio 3/4"



UNI/ISO 3316 DIN 3123

L mm	Ø mm	□	■	€		
65	47	1"	3/4	35,00	2	009290801

! E' assolutamente necessario commisurare la coppia di serraggio alla capacità del quadro maschio per evitare rotture o danni accidentali

929/21 - 929/22

prolunghe con attacchi quadri maschio e femmina 1"



UNI/ISO 3316 DIN 3123

	L mm	Ø mm	€		
929/21	200	47	46,00	1	009290815
929/22	400	47	66,00	1	009290825

929/42

quadro maschio 1" con spina scorrevole



UNI/ISO 3315 DIN 3122

L mm	€		
535	85,00	1	009290850

929/55

cricchetto reversibile con attacco quadro maschio 1" meccanismo a 72 denti



UNI/ISO 3315 DIN 3122

L mm	Ø mm	A mm	€		
770	62	63	182,00	1	009290860

929/C8

8 chiavi a bussola esagonali e 5 accessori



929/C8 € 1.078,00 1 009290925

929	46 - 50 - 55 - 60 - 65 70 - 75 - 80 mm
929/15	□ 1" - ■ 3/4
929/21	200 mm
929/22	400 mm
929/42	
929/55	

560x290x12 mm - 29 kg

900/R55



900/R55 € 30,00 1 009000871

900/R55-Z



900/R55-Z € 30,00 1 009000872

900M/R55



900M/R55 € 15,50 1 009000888

910/R55



910/R55 € 29,50 1 009100879

599DGT/6-606/6-606/10-612
665/5-665/10-665LB/6-665LB/10
666N/5-666N/10-666N LBF.IN/5-666N
LBF.IN
666/6-666/10-910/55

910M/R55



910M/R55 € 16,00 1 009100888

910/R55Q



910/R55Q € 29,50 1 009100877

910/R55X



910/R55X
666N/2X € 29,50 1 009100897

920/R50



920/R50
614/50-667/20-667/30
920/50 € 29,00 1 009200866

920/R55



920/R55
606/20-606/30-666/20-666/30
920/55-920/56A- 599DGT/20-
599DGT/30-599DGT-AN/20
665/20-665/30-665LB/20-665LB/30
666N/20-666N/30-666N LBF.IN/20-666N
LBF.IN/30 € 34,50 1 009200879

920M/R55



920M/R55
920M/55-920M/56 € 18,00 1 009200888

920/R55Q



920/R55Q
920/55Q € 34,50 1 009200877

920/R55X



920/R55X
606/10X-612X
666/10X-920/55X-599DGT/10X-599DGT-
AN/10
665/10X-665LB/10X-666N10X-666N
LBF.IN/10X € 29,00 1 009200878

920/R55LC



920/R55LC
920/55LC "Locking System" € 36,50 1 009200887

928/R55



928/R55
928/55 € 58,00 1 009280859

928/R55X



928/R55X
614X € 37,00 1 009280858

929/R55



929/R55
929/55 € 67,00 1 009290859



930

chiavi a tubo doppie poligonali
serie pesante



UNI 6745

mm	L mm	Ø mm	Ø1 mm	€		
6x7	100	9,5	11,0	11,20	3	009300006
8x9	108	12,5	14,0	14,10	3	009300010
10x11	116	15,0	16,5	14,80	3	009300014
12x13	124	17,5	19,0	17,30	3	009300018
14x15	132	20,0	21,5	18,90	3	009300023
16x17	140	23,0	24,0	21,70	3	009300027
18x19	148	25,0	26,5	24,00	3	009300032
20x22	156	28,0	30,0	26,50	2	009300036
21x23	163	29,0	31,5	28,50	2	009300040
24x26	173	33,0	35,5	36,00	2	009300044
25x28	182	34,5	38,0	39,50	2	009300048
27x29	191	37,0	39,5	45,00	2	009300052
30x32	200	40,5	43,0	54,00	2	009300056



930/S8 € 159,50 1 009300081

6x7-8x9-10x11
12x13-14x15-16x17
18x19-20x22 mm

940/1 - /2

930/S13 € 374,00 1 009300083

6x7-8x9-10x11-12x13
14x15-16x17-18x19
20x22-21x23-24x26
25x28-27x29-30x32 mm

940/1 - /2 - /3



930/C13 € 423,00 1 009300098

6x7-8x9-10x11-12x13
14x15-16x17-18x19
20x22-21x23-24x26
25x28-27x29-30x32 mm

940/1 - /2 - /3

932

chiavi a pipa doppie
esagonali-poligonali
cromate lucide

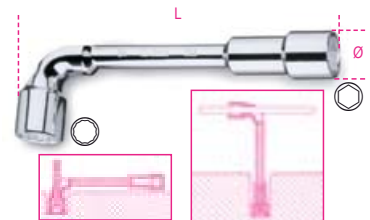

NF E 74.303

mm	Ø mm	L mm	€		
6x6	11,5	110	12,50	5	009320006
7x7	12,5	116	12,70	5	009320007
8x8	13,0	120	13,30	5	009320008
9x9	14,0	125	13,80	5	009320009
10x10	16,5	133	14,30	5	009320010
11x11	17,5	143	15,50	5	009320011
12x12	19,0	148	16,60	5	009320012
13x13	19,5	154	17,20	5	009320013
14x14	21,5	167	18,20	5	009320014
15x15	22,5	182	19,20	5	009320015
16x16	24,5	193	20,00	5	009320016
17x17	26,0	198	20,20	5	009320017
18x18	26,5	215	22,10	5	009320018
19x19	29,0	220	24,20	5	009320019
20x20	30,5	222	25,50	3	009320020
21x21	30,5	236	29,50	3	009320021
22x22	32,5	250	32,50	2	009320022
23x23	33,5	256	35,50	2	009320023
24x24	35,0	272	38,50	2	009320024
25x25	36,5	282	41,00	2	009320025
26x26	37,5	296	45,50	2	009320026
27x27	39,0	296	47,50	2	009320027
28x28	39,0	314	53,50	2	009320028
30x30	42,5	348	63,50	2	009320030
32x32	45,5	364	71,00	2	009320032



932/S11	€ 197,50	1	009320080
6-7-8-10-11-12 13-14-17-19-22 mm			
932/S17	€ 328,00	1	009320081
6-7-8-9-10-11-12 13-14-15-16-17 18-19-20-21-22 mm			
932/S25	€ 724,00	1	009320082
6-7-8-9-10-11-12-13 14-15-16-17-18-19 20-21-22-23-24-25 26-27-28-30-32 mm			

933

chiavi a pipa doppie
esagonali
cromate lucide

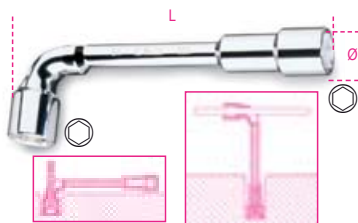

NF E 74.303

mm	Ø mm	L mm	€		
6x6	11,5	110	12,50	5	009330006
7x7	12,5	116	12,70	5	009330007
8x8	13,0	120	13,30	5	009330008
9x9	14,0	125	13,80	5	009330009
10x10	16,5	133	14,30	5	009330010
11x11	17,5	143	15,50	5	009330011
12x12	19,0	148	16,60	5	009330012
13x13	19,5	154	17,20	5	009330013
14x14	21,5	167	18,20	5	009330014
15x15	22,5	182	19,20	5	009330015
16x16	24,5	193	20,00	5	009330016
17x17	26,0	198	20,20	5	009330017
18x18	26,5	215	22,10	5	009330018
19x19	29,0	220	24,20	5	009330019
20x20	30,5	222	25,50	3	009330020
21x21	30,5	236	29,50	3	009330021
22x22	32,5	250	32,50	2	009330022
23x23	33,5	256	35,50	2	009330023
24x24	35,0	272	38,50	2	009330024
25x25	36,5	282	41,00	2	009330025
26x26	37,5	296	45,50	2	009330026
27x27	39,0	296	47,50	2	009330027
28x28	39,0	314	53,50	2	009330028
30x30	42,5	348	63,50	2	009330030
32x32	45,5	364	71,00	2	009330032



933/S11	€ 197,50	1	009330080
6-7-8-10-11-12 13-14-17-19-22 mm			
933/S17	€ 328,00	1	009330081
6-7-8-9-10-11-12 13-14-15-16-17 18-19-20-21-22 mm			
933/S25	€ 724,00	1	009330082
6-7-8-9-10-11-12-13 14-15-16-17-18-19 20-21-22-23-24-25 26-27-28-30-32 mm			

935

chiavi a tubo doppie
esagonali
serie leggera



UNI 6746 DIN 896

mm	L mm	€		
6x7	100	6,50	5	009350105
8x9	110	7,00	5	009350111
10x11	120	7,80	5	009350115
12x13	130	8,80	5	009350117
14x15	140	10,20	5	009350126
16x17	150	11,20	5	009350128
18x19	160	13,30	5	009350131
20x22	170	16,00	3	009350138
21x23	180	17,80	3	009350141
24x26	190	20,30	3	009350144
25x28	200	22,50	2	009350150
27x29	210	26,00	2	009350153
30x32	220	28,50	2	009350156

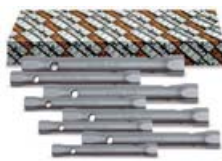

935/S8	€ 92,00	1	009350181
6x7-8x9-10x11 12x13-14x15-16x17 18x19-20x22 mm			
935/S13	€ 218,50	1	009350183
6x7-8x9-10x11 12x13-14x15-16x17 18x19-20x22-21x23 24x26-25x28-27x29 30x32 mm			
940/1 - /2 - /3			

937

chiavi a pipa doppie
esagonali-poligonali
cromate

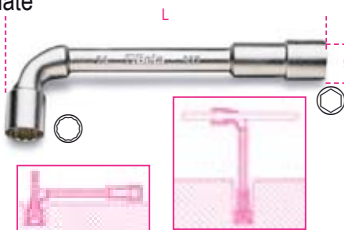

mm	Ø mm	L mm	€		
6x6	11,5	110	7,00	5	009370006
7x7	12,5	116	7,30	5	009370007
8x8	13,0	120	7,60	5	009370008
9x9	14,0	125	8,00	5	009370009
10x10	16,5	133	8,40	5	009370010
11x11	17,5	143	8,80	5	009370011
12x12	19,0	148	9,70	5	009370012
13x13	19,5	154	10,00	5	009370013
14x14	21,5	167	11,00	5	009370014
15x15	22,5	182	12,20	5	009370015
16x16	24,5	193	13,20	5	009370016
17x17	26,0	198	13,70	5	009370017
18x18	26,5	215	14,00	5	009370018
19x19	29,0	220	14,50	5	009370019
20x20	30,5	222	16,50	3	009370020
21x21	30,5	236	18,00	3	009370021
22x22	32,5	250	19,00	2	009370022
23x23	33,5	256	21,00	2	009370023
24x24	35,0	272	22,00	2	009370024
25x25	36,5	282	28,00	2	009370025
26x26	37,5	296	29,00	2	009370026
27x27	39,0	296	29,50	2	009370027
28x28	39,0	314	35,00	2	009370028
30x30	42,5	348	38,00	2	009370030
32x32	45,5	364	42,50	2	009370032



937/S11	€ 117,00	1	009370080
6-7-8-10-11-12 13-14-17-19-22 mm			
937/S17	€ 199,00	1	009370081
6-7-8-9-10-11-12 13-14-15-16-17 18-19-20-21-22 mm			

940

spine di manovra per 930-935



	mm	L mm	€		
940/1	6÷13	100	4,80	5	009400001
940/2	14÷22	170	6,30	5	009400002
940/3	21÷32	290	11,50	5	009400003

941

chiavi a pipa esagonali-poligonali
con impugnatura di manovra

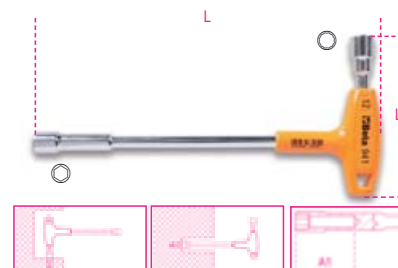

mm	L mm	L1 mm	A1 mm	€		
7x7	200	91	35	23,50	2	009410107
8x8	220	107	50	25,50	2	009410108
9x9	220	109	50	25,50	2	009410109
10x10	236	111	50	26,00	2	009410110
11x11	236	114	50	27,50	2	009410111
12x12	255	122	50	30,50	2	009410112
13x13	255	124	55	31,00	2	009410113



941/S7	€ 189,50	1	009410170
7-8-9-10-11-12-13 mm			

942BX

chiavi a bussola esagonale tipo corto



UNI 6750

mm	L mm	L1 mm	A1 mm	€	U	IT
4	190	70	13,0	11,70	5	009420003
5	190	70	14,0	11,70	5	009420004
5,5	190	70	12,5	13,30	5	009420005
6	190	70	14,5	13,30	5	009420006
7	190	70	15,5	13,90	5	009420007
8	202	70	18,5	13,90	5	009420008
9	202	70	19,5	13,90	5	009420009
10	202	70	20,5	14,80	3	009420010
11	202	70	21,5	14,80	3	009420011
12	202	70	22,5	14,80	3	009420012
13	202	70	23,5	16,70	3	009420013
14	202	70	24,5	16,70	3	009420014



mm	L mm	L1 mm	A1 mm	€	U	IT
4-5-5,5-6-7-8-9	190	70	13,0-14,0-12,5-14,5-15,5-18,5-19,5	169,50	1	009420030

943BX

chiavi a bussola esagonale tipo lungo



ISO 2236 UNI 6750

mm	L mm	L1 mm	A1 mm	€	U	IT
4	270	150	13,0	13,00	5	009430003
5	270	150	14,0	13,00	5	009430004
5,5	270	150	12,5	14,00	5	009430005
6	270	150	14,5	14,00	5	009430006
7	270	150	15,5	15,00	5	009430007
8	282	150	18,5	15,00	5	009430008
9	282	150	19,5	15,00	5	009430009
10	282	150	20,5	16,30	3	009430010
11	282	150	21,5	16,30	3	009430011
12	282	150	22,5	16,30	3	009430012
13	282	150	23,5	17,30	3	009430013
14	282	150	24,5	17,30	3	009430014



mm	L mm	L1 mm	A1 mm	€	U	IT
4-5-5,5-6-7-8-9	270	150	13,0-14,0-12,5-14,5-15,5-18,5-19,5	182,50	1	009430030

Betamax



mm	L mm	L1 mm	A1 mm	€	U	IT
5-6-7-8-10-13	190	70	13,0-14,0-12,5-14,5-15,5-18,5-19,5	90,50	1	009430026

943FL

chiavi a bussola esagonale flessibili con impugnatura



mm	L mm	L1 mm	Ø mm	€	U	IT
5	265	150	8	18,30	2	009430304
5,5	265	150	8	18,30	2	009430305
6	265	150	9	18,30	2	009430306
7	265	150	11	18,30	2	009430307
8	265	150	12	19,00	2	009430308
10	290	175	14	20,50	2	009430310



mm	L mm	L1 mm	A1 mm	€	U	IT
5-5,5-6-7-8-10	265	150	8-9-11-12	112,50	1	009430320

944BX

chiavi a bussola esagonale profonda tipo lungo



ISO 2236 UNI 6750

mm	L mm	L1 mm	A1 mm	€	U	IT
4	245	125	20	13,50	3	009440003
5	245	125	25	13,50	3	009440004
5,5	245	125	30	16,50	3	009440005
6	245	125	35	16,50	3	009440006
7	245	125	35	16,50	3	009440007
8	257	125	50	17,70	3	009440008
9	257	125	50	17,70	3	009440009
10	257	125	50	18,50	3	009440010
11	257	125	50	18,50	3	009440011
12	257	125	50	20,30	3	009440012
13	257	125	55	20,30	3	009440013
14	257	125	55	20,30	3	009440014

Betamax



mm	L mm	L1 mm	A1 mm	€	U	IT
4-5-5,5-6-7-8-9	190	70	13,0-14,0-12,5-14,5-15,5-18,5-19,5	210,00	1	009440062

Betamax



mm	L mm	L1 mm	A1 mm	€	U	IT
5-6-7-8-10-13	190	70	13,0-14,0-12,5-14,5-15,5-18,5-19,5	103,00	1	009440056

949

chiavi a T semplici con bussola esagonale profonda



mm	L mm	L1 mm	A1 mm	€	U	IT
8	220	160	50	24,50	2	009490008
10	230	160	50	25,50	2	009490010
12	240	175	50	26,50	2	009490012
13	244	175	55	27,50	2	009490013
14	250	190	55	29,50	2	009490014
17	264	200	60	33,50	2	009490017



mm	L mm	L1 mm	A1 mm	€	U	IT
8-10-12-13-14-17	220	160	50-55-60	167,00	1	009490076



950

chiavi a T semplici
esagonali

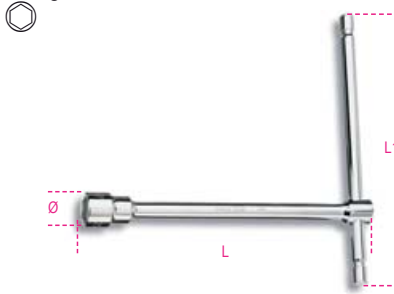

UNI 6742 DIN 3112

mm	L	Ø	L1	€		
6	210	10,1	145	17,00	3	009500006
7	212	11,2	145	17,00	3	009500007
8	220	12,4	160	18,30	3	009500008
9	223	13,5	160	18,30	3	009500009
10	230	14,9	160	19,80	3	009500010
11	233	16,1	160	19,80	3	009500011
12	240	17,5	175	22,00	3	009500012
13	244	19,7	175	22,00	3	009500013
14	250	20,1	190	24,50	3	009500014
15	254	21,5	190	25,50	3	009500015
16	260	22,7	200	28,50	3	009500016
17	264	24,1	200	29,50	3	009500017
19	274	26,6	230	36,00	3	009500019
22	290	29,9	290	43,50	2	009500022
24	300	32,2	320	49,00	2	009500024
27	315	36,2	370	58,00	2	009500027



950/S9 7-8-10-11-12 13-14-17-19 mm	€ 209,00	1	009500079
950/S14 6-7-8-9-10-11-12-13 14-15-16-17-19-22 mm	€ 342,00	1	009500082

951

chiavi a T con tre estremità
maschio esagonale

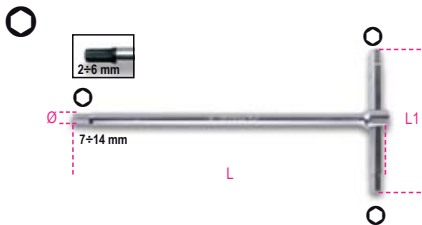

mm	L	L1	Ø	€		
2	125	63	4,0	15,50	5	009510521
2,5	150	63	4,0	15,50	5	009510525
3	150	63	4,0	15,50	5	009510530
3,5	175	76	5,5	16,00	5	009510535
4	175	76	5,5	16,00	5	009510540
4,5	195	87	6,5	17,50	5	009510545
5	195	87	6,5	17,50	5	009510550
6	215	99	8,0	20,30	5	009510560
7	230	109	9,0	22,00	5	009510570
8	250	122	10,0	22,00	5	009510580
9	265	132	11,0	27,50	5	009510590
10	280	142	12,0	27,50	5	009510610
12	305	160	15,0	37,50	3	009510620
14	330	178	17,0	45,00	3	009510640

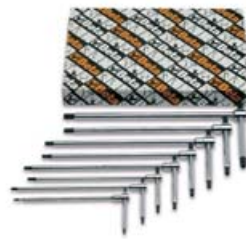

951/S6 2,5-3-4-5-6-8 mm	€ 107,00	1	009510687
951/S8 2-2,5-3-3,5-4-4,5-5-6 mm	€ 134,00	1	009510693
951/S14 2-2,5-3-3,5-4-4,5 5-6-7-8-9-10-12-14 mm	€ 315,00	1	009510695



951/SP6 3-4-5-6-8-10 mm	€ 136,50	1	009510696
951/SPV	€ 25,00	1	009510697

951AS

chiavi a T con tre estremità
maschio esagonale

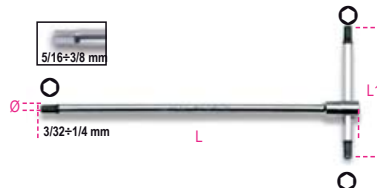

"	L	L1	Ø	€		
3/32	125	63	4,0	20,80	2	009510750
7/64	150	63	4,0	20,80	2	009510751
1/8	150	63	4,0	20,80	2	009510752
9/64	175	76	5,5	21,80	2	009510753
5/32	175	76	5,5	21,80	2	009510754
3/16	195	86	6,5	23,80	2	009510755
7/32	215	99	8,0	23,80	2	009510757
1/4	230	109	9,0	27,00	2	009510758
5/16	250	122	10,0	27,50	2	009510759
3/8	280	142	12,0	33,50	2	009510760



951AS/S6X 1/8-3/16-7/32-1/4-5/16-3/8	€ 156,00	1	009510771
--	----------	---	-----------

951TX

chiavi a T con tre estremità maschio
per viti con impronta Torx®



mm	L	L1	Ø	€		
T6	125	63	4	19,30	3	009510806
T7	125	63	4	19,30	3	009510807
T8	125	63	4	19,80	3	009510808
T9	125	63	4	19,80	3	009510809
T10	150	63	4	20,30	3	009510810
T15	150	63	4	20,30	3	009510815
T20	175	76	5	21,30	3	009510820
T25	175	76	5	21,30	3	009510825
T27	195	87	6	22,90	3	009510827
T30	195	87	6	22,90	3	009510830
T40	215	99	7	26,00	3	009510840
T45	230	109	8	28,00	3	009510845
T50	250	122	9	30,00	3	009510850

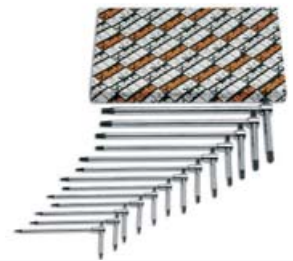

951TX/S6 T8-T10-T15-T20-T25-T30	€ 126,00	1	009510866
951TX/S13 T6-T7-T8-T9-T10-T15-T20-T25 T27-T30-T40-T45-T50	€ 291,00	1	009510863

952

chiavi a T con bussola esagonale
snodata

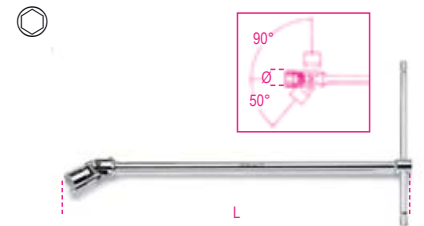

UNI 6743

mm	Ø	L	€		
6	9,5	395	26,00	5	009520006
7	10,7	395	26,00	5	009520007
8	12,1	395	26,00	5	009520008
9	13,2	395	26,00	5	009520009
10	14,6	400	28,50	5	009520010
11	15,8	400	28,50	5	009520011
12	17,0	400	28,50	5	009520012
13	18,7	432	30,50	5	009520013
14	19,7	432	30,50	5	009520014
15	20,9	450	37,50	3	009520015
16	22,0	450	37,50	3	009520016
17	23,4	450	37,50	3	009520017
18	24,7	450	37,50	3	009520018
19	26,0	500	46,00	3	009520019
20	27,4	500	46,00	3	009520020
21	28,5	500	46,00	3	009520021
22	29,7	500	46,00	3	009520022
24	32,4	500	46,00	3	009520024



952/S7	€ 227,50	1	009520074
8-10-11-13-14-17-19 mm			
952/S10	€ 319,00	1	009520080
7-8-10-11-12-13-14-15-17-19 mm			
952/S18	€ 630,00	1	009520083
6-7-8-9-10-11-12-13-14-15-16-17-18-19-20-21-22-24 mm			

852



852	€ 79,85		
------------	---------	--	--

952AS

chiavi a T con bussola esagonale snodata

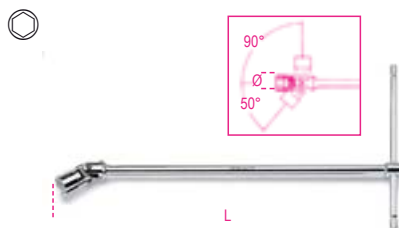

mm	Ø mm	L mm	€		
1/4	9,5	395	29,00	2	009520256
5/16	12,1	395	29,00	2	009520258
3/8	14,6	400	31,00	2	009520260
7/16	15,8	400	31,00	2	009520261
1/2	18,7	432	34,50	2	009520263
9/16	19,7	432	37,50	2	009520264
5/8	22,0	450	40,00	2	009520266
11/16	23,4	450	40,00	2	009520267
3/4	26,0	500	49,50	2	009520269

952L

chiavi a T con bussola esagonale snodata, tipo lungo

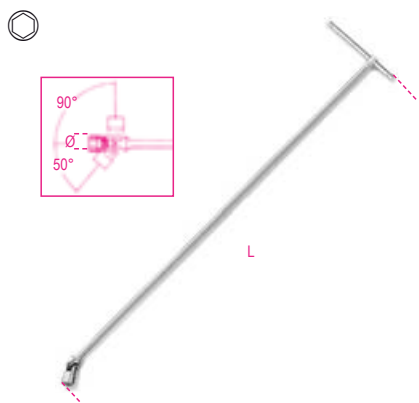

mm	Ø mm	L mm	€		
10	14,6	930	72,00	1	009520410
12	17,0	1063	72,00	1	009520412
13	18,7	1100	72,00	1	009520413
14	19,7	1100	72,00	1	009520414

mm	Ø mm	L mm	€		
15	20,9	1100	81,00	1	009520415
16	22,0	1100	81,00	1	009520416
17	23,4	1100	81,00	1	009520417
18	24,7	1100	81,00	1	009520418
19	26,0	1100	94,00	1	009520419

952FTX

chiavi a T con bussola snodata per viti con testa a profilo Torx®

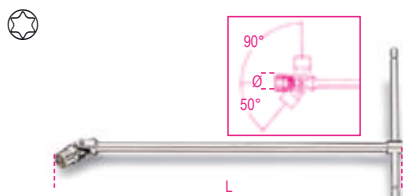

Ø mm	L mm	€		
E6	8 392	31,00	2	009520106
E7	9 392	31,00	2	009520107
E8	10 395	35,50	2	009520108
E10	13 400	36,50	2	009520110
E12	15 440	44,00	2	009520112
E14	17 490	53,50	2	009520114
E16	19 490	53,50	2	009520116
E18	21 490	53,50	2	009520118
E20	23 490	53,50	2	009520120



952FTX/S9	€ 392,00	1	009520141
E6-E7-E8-E10-E12-E14-E16-E18-E20			

953

chiavi a T con maschio esagonale snodato

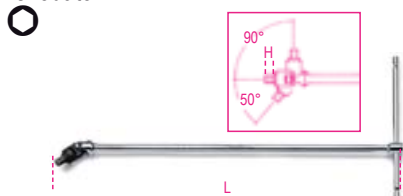

UNI 6754

mm	H mm	L mm	€		
3	5	395	27,00	5	009530130
3,5	6	395	27,00	3	009530135
4	6	395	27,00	5	009530140
4,5	7	395	27,00	3	009530145
5	7	395	27,00	5	009530150
6	9	400	29,50	5	009530160
7	10	425	32,50	3	009530170
8	11	425	32,50	5	009530180
10	13	440	38,50	5	009530200



953/S5	€ 143,00	1	009530305
3-4-5-6-8 mm			
953/S9	€ 268,00	1	009530301
3-3,5-4-4,5-5-6-7-8-10 mm			

953TX

chiavi a T con maschio snodato per viti con impronta Torx®

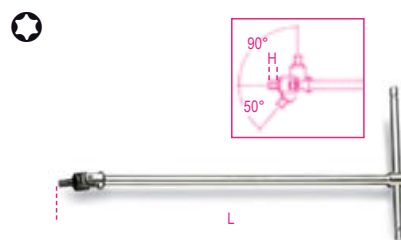

Ø mm	H mm	L mm	€		
T20	11	396	33,00	2	009530020
T25	11	396	33,00	2	009530025
T27	11	396	33,00	2	009530027
T30	13	400	36,50	2	009530030
T40	13	400	36,50	2	009530040
T45	13	426	37,50	2	009530045
T50	14	442	44,00	2	009530050
T55	14	442	44,50	2	009530055



953TX/S8	€ 298,00	1	009530060
T20-T25-T27-T30-T40-T45-T50-T55			

955

chiave a tubo semplice per candele d'accensione



mm - "	D mm	L mm	€		
16	21	86	13,00	3	009550016
5/8					
20,8	29	86	13,00	3	009550021
13/16					

956C

chiavi a bussola con attacco quadro femmina 1/2" per candele d'accensione



ISO 11168

mm - "	Ø mm	L mm	€		
14	18,8	70	24,30	3	009560008
9/16					
16	21,4	70	24,30	3	009560010
5/8					
17,8	23,6	70	24,30	3	009560011
11/16					
20,8	27,0	70	24,80	3	009560012
13/16					

956E

chiavi a bussola
con attacco quadro femmina 3/8"
per candele d'accensione



ISO 11168

mm -"	Ø mm	L mm	€	3	009560018
14	18,8	70	26,50	3	009560018
9/16					
16	21,4	70	26,50	3	009560020
5/8					
17,8	23,6	70	26,50	3	009560021
11/16					
20,8	27,0	70	27,00	3	009560022
13/16					

956F

chiavi a bussola
con attacco quadro femmina 3/8"
per candele d'accensione



mm -"	Ø mm	L mm	€	1	009560114
14	18,8	70	30,00	1	009560114
9/16					
16	20,5	70	37,00	1	009560116
5/8					

956L

chiavi a bussola poligonale
con attacco quadro femmina 1/2"
tipo lungo, per candele d'accensione



mm -"	Ø mm	L mm	€	2	009560214
14	20,2	250	49,00	2	009560214
9/16					
16	24,0	250	51,00	2	009560216
5/8					
17,8	24,0	250	54,00	2	009560217
11/16					
20,8	28,5	250	55,00	2	009560221
13/16					

957

chiavi a T con bussola snodata
per candele d'accensione

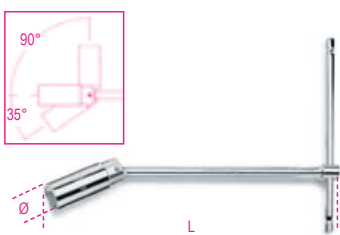

ISO 11168

mm -"	Ø mm	L mm	€	3	009570000
16	21,4	275	37,50	3	009570000
5/8					
20,8	27,0	275	44,00	3	009570001
13/16					

959

chiavi a T con bussola snodata
tipo normale, per candele d'accensione

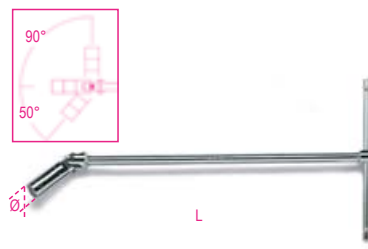

ISO 11168

mm -"	Ø mm	L mm	€	3	009590009
14	18,8	483	43,50	3	009590009
9/16					
16	21,4	483	48,00	3	009590010
5/8					
20,8	27,0	527	64,00	3	009590011
13/16					

959R

gommino e molla di ricambio
per 956C - 956E - 957 - 959

959R/14	€	3	009590223
956C/14-956E/14	4,50	3	009590223
959R/16	4,50	3	009590224
956C/16-956E/16			
957/16-959/16			
959R/17,8	4,50	3	009590225
956C/17,8-956E/17,8			
959R/20,8	4,50	3	009590226
956C/20,8-956E/20,8			
957/20,8-959/20,8-959L			

960

chiavi a bussola
con attacco quadro femmina 1/2"
per iniettori motori Diesel



mm	Ø mm	L mm	€	2	009600027
27	36,5	77	28,50	2	009600027

960A

chiavi a bussola
con attacco quadro femmina 1/2"
per iniettori motori Diesel

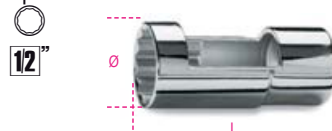

mm	Ø mm	L mm	€	2	009600017
27	36,5	77	40,50	2	009600017

960BT

chiavi a bussola per le connessioni elettriche
degli iniettori



mm	Ø mm	L mm	€	1	009600125
25	37,0	78	69,00	1	009600125
27	39,7	78	69,00	1	009600127
29	42,0	78	69,00	1	009600129
30	43,0	78	69,00	1	009600130

960BT/B

chiavi a bussola per le connessioni elettriche
degli iniettori

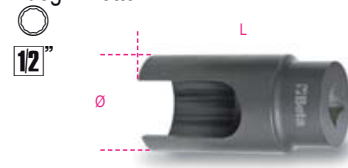

mm	Ø mm	L mm	€	1	009600128
29	38,5	77	99,00	1	009600128

960F

chiave a bussola
per ghiere portainiettori



mm	Ø mm	Ø1 mm	Ø2 mm	€	1	009600148
28,3	22	32	22	32,50	1	009600148

960G

chiave a bussola
per ghiere portainiettori



mm	Ø mm	Ø1 mm	L mm	€	1	009600151
28,5	22	32	122	34,50	1	009600151

960L

chiave a bussola
per ghiere portainiettori

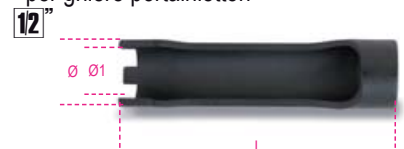

mm	Ø mm	Ø1 mm	L mm	€	1	009600153
30	22	32	122	37,50	1	009600153

960M

chiave a bussola
per ghiera portainiettori

12"

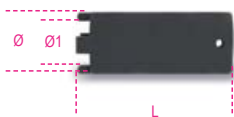

Ø mm	Ø1 mm	L mm	€	1	009600154
28,5	22	72	27,50		

960H/C4

serie di bussole per ghiera portainiettori



960H/C4	€	1	009600152
	98,00		

960S

chiavi a bussola
con attacco quadro femmina 1/2"
per iniettori motori Diesel

12"



Ø mm	L mm	€	1	009600022
22	82	32,00		

960SL

chiavi a bussola per sonda Lambda
con attacco quadro femmina 1/2"

12"



960SL85	Ø mm	€	2	009600085
○ 22xL= 85 mm	33	48,50		
960SL110	Ø mm	€	2	009600110
○ 22xL= 110 mm	33	55,50		

960SN

chiavi per candele
di preriscaldamento motori Diesel

14"

3/8"



Ø mm	L mm	€	2	009600834
8	60	42,00		
9	60	42,00		
10	70	49,50		
11	70	49,50		
12	70	49,50		

960T/C11

assortimento bussole
per rimozione/installazione
sensori

incluse nel kit:

- 1 bussola esagonale doppia misura 1" - 1 1/16" per sensori di pressione olio
- 1 bussola esagonale aperta 29 mm per sensori ossigeno
- 1 bussola poligonale aperta 27 mm per iniettori
- 1 bussola esagonale aperta 22 mm per vacuostato
- 1 bussola esagonale aperta 22 mm lunga 80 mm per sensori ossigeno
- 1 bussola esagonale aperta 22 mm lunga 98 mm per sensori ossigeno
- 1 bussola esagonale aperta 22 mm compatta lunga 30 mm per sensori ossigeno
- 1 bussola esagonale aperta 22 mm compatta lunga 50 mm per sensori ossigeno
- 1 bussola aperta 22 mm compatta lunga 34 mm ad impronta esagonale e poligonale, per sensori ossigeno
- 1 bussola esagonale aperta 22 mm con geometria a tubo
- 1 maschio M18x1,5

12"

3/8"

3/8"

12"



22 - 29 mm

960T/C11	€	1	009600031
	162,00		

330x270x25 mm

960T/A

bussola esagonale aperta 29 mm
per sensori ossigeno

12"

12"



Ø mm	L mm	€	1	009600032
29	90	19,00		

960T/B

bussola poligonale aperta 27 mm
per iniettori

12"

12"



Ø mm	L mm	€	1	009600033
27	85	16,80		

960T/C

bussola esagonale aperta 22 mm
per vacuostato

12"



Ø mm	L mm	€	1	009600034
22	88	14,70		

960T/D

bussola esagonale aperta 22 mm lunga 90
mm
per sensori ossigeno

3/8"

3/8"



Ø mm	L mm	€	1	009600035
22	90	13,40		

960T/E

bussola esagonale aperta 22 mm lunga 80
mm
per sensori ossigeno

3/8"

3/8"



Ø mm	L mm	€	1	009600036
22	80	12,20		

960T/F

bussola esagonale doppia misura 1" - 1 1/16"
per sensori di pressione olio

3/8"

3/8"



1 - 1/16	Ø mm	L mm	€	1	009600037
	28	74	11,60		

960T/G

bussola esagonale aperta 22 mm
con geometria a tubo

12"

12"



Ø mm	L mm	€	1	009600038
22	98	33,00		

960T/H

bussola aperta 22 mm compatta lunga 34 mm ad impronta esagonale e poligonale, per sensori ossigeno



mm	L1 mm	L2 mm	€		
22	34	55	12,20	1	009600039

960T/I

bussola esagonale aperta 22 mm compatta lunga 30 mm per sensori ossigeno



mm	L1 mm	L2 mm	€		
22	30	81	16,30	1	009600040

960T/L

bussola esagonale aperta 22 mm compatta lunga 50 mm per sensori ossigeno



mm	L1 mm	L2 mm	€		
17	50	58	12,40	1	009600041

960T/M

maschio M18x1,5



mm	L mm	€		
21	50	4,10	1	009600042

960/22EP

chiave snodata a doppia impronta per sonde Lambda grande versatilità d'uso grazie alla doppia impronta esagonale/poligonale e allo snodo a 180°



L mm	mm	mm	€		
300	22	22	44,50	1	009600052

960/C6

chiavi esagonali con attacco quadro femmina 3/8"

per rimozione/installazione sensori di temperatura gas di scarico

Incluse nel kit:

- 3 misure in versione corta 13, 14, 17 mm
- 3 misure in versione lunga 13,14,17 mm



960/C6	€		
	66,50	1	009600055

170x120x50 mm

960/D

chiavi esagonali aperte versione lunga per rimozione/installazione sensori di temperatura gas di scarico



mm	€		
13	10,20	1	009600073
14	10,20	1	009600074
17	12,30	1	009600077

960YP

chiavi esagonali aperte versione piegata per rimozione/installazione sensori di temperatura gas di scarico



mm	€		
13	10,80	1	009600063
14	11,30	1	009600064
17	14,80	1	009600067

960AVE

attrezzo verifica elettroiniezioni Diesel Common Rail BOSCH, SIEMENS, DENSO e DELPHI.



960AVE	€		
	218,00	1	009600245

430x310x50 mm - 2,0 kg

960CMB

strumento per controllo compressione su motori a benzina



Bar	€		
4÷17	515,00	1	009600250

440x370x100 mm - 2,2 kg

960CMB/R2

n° 48 schede di ricambio per 960CMB



960CMB/R2	€		
	26,50	1	009600252

960CMD

strumento per controllo
compressione su motori Diesel



Bar
8÷40 € 572,00 1 009600270
440x370x100 mm - 2,4 kg

960CMD/R1

n° 48 schede di ricambio per 960CMD



960CMD/R1 € 26,50 1 009600271

960EPC

set di utensili per l'estrazione dell'elettrodo
delle candele di preriscaldamento
M8x1 - M9x1 - M10x1 - M10x1,25



960EPC € 525,00 1 009600790
270x230x80 mm - 900 g

960EPC/L

set di utensili per l'estrazione della punta
elettrodo delle candele di preriscaldamento
M8x1 - M9x1 - M10x1 - M10x1,25
versione lunga



960EPC/L € 715,00 1 009600890
270x230x80 mm - 2 kg

960E-PI/P

estrattore per rondelle iniettori

• filetto maschio M10 per utilizzo
con estrattore a massa battente (Beta 1540)



960E-PI/P € 56,50 1 009600706
300x90x60 mm

960KC-M8/M9/M10

assortimento di utensili per la rimozione
delle candele di preriscaldamento spezzate
o danneggiate

• Per candele con filetto M8-M9-M10



960KC-M8/9/10 € 362,00 1 009600801
380x290x50 mm - 2,3 kg

960KPC

estrattore reversibile ad impulsi
con coppia regolabile
per candele di preriscaldamento
Coppia regolabile in 4 posizioni:
10-20-30-40 Nm

1/4"

CE



960KPC € 267,00 1 009600780
8-9-10-11-12 mm
420x185x60 mm - 2,8 kg

960UC

set di utensili per estrazione candele
bloccate
con punta deformata
M8-M9-M10



960UC € 415,00 1 009600900
270x230x80 mm - 2,6 kg

960P

tester per controllo pressione/depressione
con accessori e adattatori



960P € 215,00 1 009600777
350x320x95 mm - 1,9 kg

960PI

assortimento di alesatori per la pulizia della sede iniettori
in cassetta di plastica

Per pulire i residui all'interno della sede iniettori

- Alesatore piatto da Ø 19 - 15 mm per iniettori universali
- Alesatore piatto da Ø 17 - 17 mm per iniettori Delphi/Bosch (BMW/PSA/Renault/Ford)
- Alesatore piatto da Ø 19 - 17 mm per iniettori Bosch (Mercedes CDI).
- Alesatore ad angolo da Ø 21 - 17 mm per iniettori Fiat/Iveco.
- Impugnatura



960PI € 100,00 1 009600215

≡ 250x130x50 mm - ■ 600 g

960PI/C19

assortimento di 19 utensili
per la pulizia sedi iniettori

Inclusi nel kit:

- 11 alesatori piatti Ø:
14/14 mm - 15,5/15,5 mm - 15/19 mm - 17/19 mm - 17/17,5 mm
17/17 - 17/19,5 mm - 17/20 mm - 18/21 mm - 19 mm - 20/21 mm
- 4 alesatori ad angolo Ø:
15,5/15,5 mm - 17/17 mm - 17,5/20,5 mm - 17/21 mm
- Impugnatura ed accessori per utilizzo frese



960PI/C19 € 250,00 1 009600217

≡ 360x230x60 mm

960PI/S

kit per pulizia sedi iniettori

Il kit include:

- 3 spazzole in acciaio Ø 18, 22, 25 mm per pulizia sedi iniettori
- 2 spazzole Ø 14 e 16 mm per pulizia fondo sedi iniettori
- 6 tappi per occlusione foro collegamento camera di combustione
- 1 scovolino per pulizia foro collegamento camera di combustione
- 1 portainseri flessibile con impugnatura

14



960PI/S € 132,00 1 009600214

≡ 360x140x50 mm - ■ 700 g

960RPI

attrezzo soffiatore per pulizia sede iniettori

Per motori con candele

M8x1 - M9x1 - M10x1 - M10x1.25



960RPI € 160,00 1 009600940

960PMC

pompa manuale per taratura e controllo iniettori Diesel



Bar Max. 600 € 630,00 1 009600200

960AVL

aspiratore di vapori



Bar Max. 6 € 710,00 1 009600210



961P6

videoscopio elettronico
con sonda flessibile



- Schermo TFT LCD 3.2"
- Supporta l'utilizzo di SD CARD (8 GB)
- Supporta memorie flash (8 GB)
- Memoria interna da 64M
- Uscita TV-OUT
- Supporta i formati video (MP4, AVI, 3GP)
- 4 led di illuminazione
- Alimentazione tramite presa USB (batteria incorporata)

CARATTERISTICHE TECNICHE

- Pixel del sensore: 640x480
- Risoluzione massima: 320x240
- Lunghezza sonda: 1 mt.
- Diametro camera: 6 mm
- Formati video: MPEG4, 3GP, AVI, ASF.
- Formati foto: JPEG
- Angolo di ripresa: 0+180°
- Uscita dati: cavo USB e SD card
- Alimentazione: batteria 3,7V 2000 mAh

961P6 € 620,00 1 009610000

961P6/S

sonde flessibili 6 mm



	L mm	€		
961P6/S1	1000	269,00	1	009610006
961P6/S2	2000	300,00	1	009610262
961P6/S3	3000	340,00	1	009610263

962

levagomme



L mm	A mm	€		
300	21	19,90	5	009620003
400	25	23,80	5	009620004
500	27	31,50	3	009620005
600	27	40,00	3	009620006

962P

levagomme con protezione
in gomma antigraffio



962M

attrezzo per smontaggio/montaggio pneumatici

particolarmente indicato per Runflat e modelli
con spalle ribassate

- ganasce antigraffio per bloccaggio su cerchi
- sede per inserimento leve smontagomme



962M	€	1	009620501
	269,00		

963

leva con estremità a punta
e piatta curva



964

leva con estremità a punta
e a becco



965

leve con estremità piatta curva



965/S3	€	1	009650019
	57,50		

966/C3

serie di 3 leve con testa snodata piatta curva



720LS

chiavi a bussola Macchina
serie lunga sottile



969B

chiave a bussola per serraggio
dado mozzo

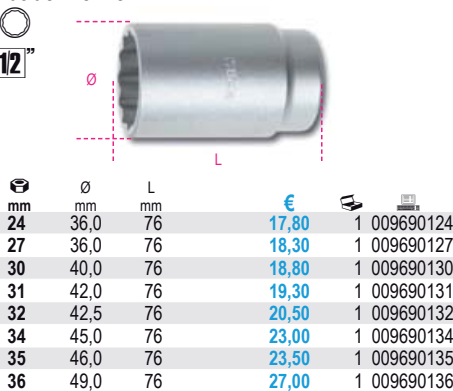

969/C5

serie di 5 chiavi a bussola
per serraggio dado mozzo
in valigetta di plastica



970EA

chiavi a bussola Macchina per dadi assale

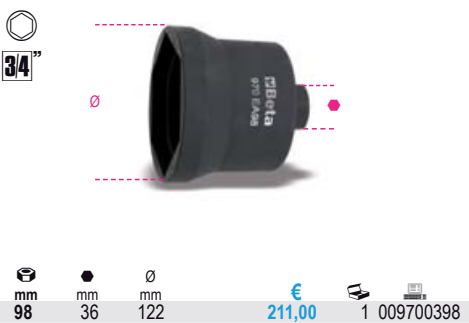

970EB

chiavi a bussola Macchina per dadi assale



970Q

chiavi a bussola Macchina per dadi
rettangolari



970B

chiave a bussola per serraggio
dadi mozzo Fiat Daily



970C

chiavi a bussola Macchina bocca ottagonale per dadi mozzi



mm	□ - ○	€		
80	41 mm	133,00	1	009700808
95	3/4"	189,00	1	009700815
100	3/4"	193,00	1	009700820
109	41 mm	199,00	1	009700829
115	3/4"	199,00	1	009700835
120	41 mm	201,00	1	009700840

9700T

chiavi a bussola Macchina bocca ovale per dadi mozzi rimorchi



L mm	L1 mm	□ - ○	€		
65	61	3/4"	113,00	1	009700165
80	73	3/4"	129,00	1	009700180
96	90	3/4"	140,00	1	009700196
111	104	41 mm	183,00	1	009700211

971TSP

strumento per sensori di pressione dei pneumatici



CARATTERISTICHE

- lettura delle informazioni dai sensori TPMS quali: ID del sensore, pressione di gonfiaggio, temperatura, stato batteria
- attivazione dei sensori
- programmazione sensori universali

Lo strumento dispone di una banca dati che supporta le operazioni di riparazione come:

- coppie di serraggio
- codici di ricambio originali e di sensori universali compatibili

	€		
971TSP	998,00	1	009710025
63x142x30 mm			

971/C8

giravite dinamometrico con accessori per il serraggio controllato delle valvole dei pneumatici con sistema di controllo della pressione



971/C8	€		
	335,00	1	009710108

	583/6	1,2+6 Nm
	892/0	
	862TX	T10-T15-T20
	900L	11-12 mm
	986 78	

973

kit di 4 protezioni in nylon per ruote

Idoneo per cerchi da:
14" a 18" codice 009730014
19" a 22" codice 009730019



- conserva e protegge la ruota da eventuali graffi e polvere
- durante lo stoccaggio, previene il precoce deterioramento dei polimeri della gomma del pneumatico estivo o invernale
- attraverso un'icona identificativa, permette la facile individuazione della posizione ruota (anteriore destra/sinistra o posteriore destra/sinistra)
- dotate di impugnatura per un comodo trasporto
- tessuto: nylon, lavabile

	€		
973 14"÷18"	85,00	1	009730014
973 19"÷22"	94,00	1	009730019

978 - 979

chiavi a croce per dadi ruote

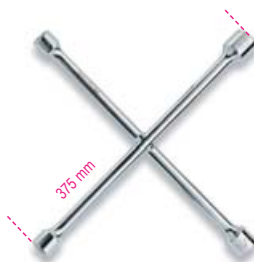

UNI/ISO 6788 DIN 3119

	€		
978	54,00	2	009780001
17x19x21x22 mm			
979	54,00	2	009790001
17x19x22x11/2 mm			

982

chiavi a croce per dadi ruote

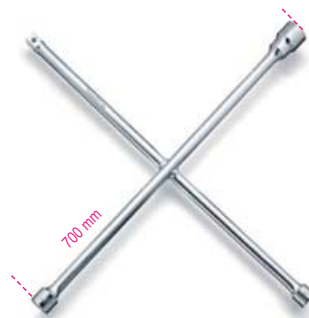

UNI/ISO 6788 DIN 3119

	€		
24x27x32x3/4 mm	130,00	1	009820001

984

pinza per coperture plastiche dadi ruote



L mm	H mm	€		
195	4	21,30	1	009840005

985/B7

assortimento di 7 perni guida per montaggio ruote

Misure incluse:

- M12x1,25 maschio
- M12x1,25 femmina
- M12x1,5 maschio
- M12x1,5 femmina
- M14x1,25 maschio
- M14x1,5 maschio
- M16x1,5 maschio



985/B7	€		
	84,00	1	009850007

985M

perni guida maschio per montaggio ruote



	L mm	€		
985M M12X1,25	150	10,80	1	009850101
985M M12X1,50	150	10,80	1	009850102
985M M14X1,25	150	11,30	1	009850103
985M M14X1,50	150	11,30	1	009850104
985M M16X1,50	150	12,30	1	009850105

985F

perni guida femmina per montaggio ruote



	L mm	€	1	009850106
985F M12X1,25	150	14,50	1	009850106
985F M12X1,50	150	15,30	1	009850107

986 48

giravite per valvole pneumatici
modello corto
ritenzione automatica della valvola



L mm	L1 mm	€	1	009860048
18	48	12,30	1	009860048

986 78

giravite per valvole pneumatici
ritenzione automatica della valvola



L mm	L1 mm	€	1	009860078
18	78	12,30	1	009860078

986PT

giravite prearato 0,4 Nm
per valvole pneumatici

ritenzione automatica della valvola
il meccanismo di slittamento permette
di non danneggiare la guarnizione
del nucleo della valvola



L mm	L1 mm	€	1	009860140
19	120	43,50	1	009860140

987

leva per valvole pneumatici
con protezione in gomma



L mm	€	1	009870001
310	25,00	1	009870001

987AR

leva per valvole pneumatici
con fulcro antigraffio
• fulcro in gomma e Nylon
per cerchi in lega ed in ferro
• attacco rapido della valvola,
non necessita di essere avvitata



L mm	€	1	009870021
305	84,00	1	009870021

987P

leva per valvole pneumatici
in materiale plastico

nel manico è incluso il giravite per agire sul
meccanismo interno alla valvola



L mm	€	1	009870011
335	21,00	1	009870011

988/K4

serie di 4 scalpelli in plastica anti graffio



988/K4	€	1	009880104
A= 19-21-25-38 mm	22,50	1	009880104

989

pinza combinata
per equilibratura ruote

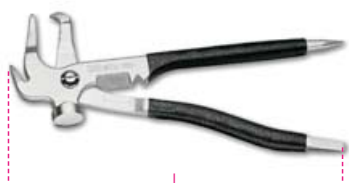

L mm	€	2	009890001
250	40,00	2	009890001

989A

pinza per rimozione piombi adesivi
equilibratura ruote



Profilo dei becchi appositamente studiato per una
rimozione dei piombi senza contatto col cerchione

989A	L mm	€	1	009890011
	220	27,50	1	009890011

990

pinzetta a molla a punte fini dritte
arrotondate, zigrinate
in acciaio inossidabile



L mm	€	5	009900001
130	9,80	5	009900001

991

pinzetta a molla a punte fini curve
arrotondate, zigrinate
in acciaio inossidabile



L mm	€	5	009910001
130	12,00	5	009910001

992

pinzetta a molla con perno
a punte fini dritte arrotondate
zigrinate, in acciaio inossidabile



L mm	€	5	009920001
150	12,50	5	009920001

993

pinzetta a molla con perno
a punte fini curve arrotondate
zigrinate, in acciaio inossidabile



L mm	€	5	009930001
145	13,50	5	009930001

993PL

pinzetta a molla a punte fini curve arrotondate, zigrinate in acciaio inossidabile



L mm 150 € 13,50 3 009930010

993G

pinzetta a molla con perno, a punte curve a gomito arrotondate, zigrinate in acciaio inossidabile



L mm 160 € 12,30 3 009930030

994

pinzetta a molla a punte larghe diritte arrotondate, zigrinate in acciaio inossidabile



L mm 150 € 10,30 5 009940001

994PL

pinzetta a molla a punte larghe diritte arrotondate, zigrinate in acciaio inossidabile



L mm 150 € 12,30 3 009940010

994TF

pinzetta a molla, antiacido antimagnetica, a punte larghe diritte arrotondate, zigrinate in acciaio inossidabile



L mm 150 € 16,50 3 009940020

996

pinzetta a molla a becchi diritti a spatola in acciaio inossidabile



L mm 150 € 10,90 5 009960001

998

pinzetta a molla a becchi larghi diritti incrociati, zigrinati in acciaio inossidabile



L mm 155 € 18,90 5 009980001

999

pinzetta a molla antiacido antimagnetica, a punte piatte arrotondate in acciaio inossidabile



L mm 115 € 14,80 3 009990011

999A

pinzette a molla, antiacido antimagnetica, a punte corte finissime in acciaio inossidabile



L mm 120 € 13,00 3 009990015

999B

pinzetta a molla, antiacido antimagnetica, a punte forti diritte in acciaio inossidabile



L mm 120 € 13,20 3 009990017

999C

pinzetta a molla, antiacido antimagnetica, a punte finissime diritte in acciaio inossidabile



L mm 110 € 14,50 3 009990019

999D

pinzetta a molla, antiacido antimagnetica, a punte finissime angolate, in acciaio inossidabile



L mm 115 € 16,00 3 009990021

999E

pinzetta a molla, antiacido antimagnetica, a punte finissime curve in acciaio inossidabile



L mm 120 € 14,50 3 009990023

999G

pinzetta a molla, antiacido, antimagnetica con dispositivo di bloccaggio, a punte finissime diritte in acciaio inossidabile



L mm 140 € 14,50 3 009990027

999/B6

serie di 6 pinzette a molla antiacido ed antimagnetiche



€ 92,50 1 009990050
999/B6
999-999A-999B
999C-999D-999E

1002

pinzetta autobloccante a becchi arrotondati, zigrinati in acciaio inossidabile

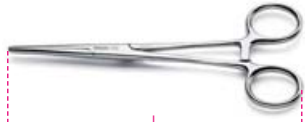

L mm 160 € 23,50 2 010020001

1008

pinze a becchi piatti lunghi zigrinati manici ricoperti con 2 strati di PVC antiscivolo

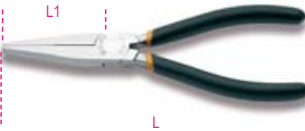

ISO 5745
L mm 160 L1 mm 51,5 € 21,50 5 010080006

1008BM

pinze a becchi piatti lunghi zigrinati impugnatura bimatériale



ISO 5745
L mm 160 L1 mm 51,5 € 26,00 3 010080036

1009

pinze a becchi mezzotondi lunghissimi zigrinati manici ricoperti con 2 strati di PVC antiscivolo



ISO 5745
L mm 160 L1 mm 56,5 € 21,50 2 010090006

1009L/A

pinza a becchi mezzotondi lunghissimi diritti zigrinati, per impieghi speciali manici ricoperti con 2 strati di PVC antiscivolo



L mm 283 L1 mm 80 € 26,00 2 010090008

1009L/B

pinza a becchi mezzotondi lunghissimi zigrinati piegati a 45° per impieghi speciali manici ricoperti con 2 strati di PVC antiscivolo



L mm 273 L1 mm 73 € 26,50 2 010090009

1009L/C

pinza a becchi mezzotondi lunghissimi zigrinati piegati a 90° per impieghi speciali manici ricoperti con 2 strati di PVC antiscivolo



L mm 253 L1 mm 45 € 28,00 2 010090010

1009L/D

pinza a becchi mezzotondi lunghissimi diritti zigrinati, con doppio snodo manici ricoperti con 2 strati di PVC antiscivolo



L mm 342 L1 mm 71 € 31,50 1 010090058

1009L/DP

pinza a becchi mezzotondi lunghissimi zigrinati piegati a 45°, con doppio snodo manici ricoperti con 2 strati di PVC antiscivolo



L mm 336 L1 mm 66 € 31,50 1 010090059

1010

pinze a becchi tondi lunghi manici ricoperti con 2 strati di PVC antiscivolo

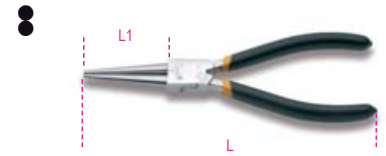

ISO 5745
L mm 160 L1 mm 51,5 € 21,50 2 010100006

1010BM

pinze a becchi tondi lunghi impugnatura bimatériale



ISO 5745
L mm 160 L1 mm 51,5 € 26,00 2 010100036

1031/S4

serie di 4 pinze per anelli elastici di sicurezza



1031/S4 € 91,50 1 010310000
1032 180 ⌀ 19 ÷ 60 mm
1034 170 ⌀ 19 ÷ 60 mm
1036 175 ⌀ 19 ÷ 60 mm
1038 175 ⌀ 19 ÷ 60 mm

1032

pinze a becchi diritti per anelli elastici di sicurezza, per fori manici ricoperti in PVC



UNI 7914 DIN 5256
L mm ⌀ mm € 5 010320013
140x0,9 8÷12 20,10 5 010320014
140x1,3 12÷25 19,70 5 010320017
180 19÷60 21,20 5 010320017
225 40÷100 26,50 3 010320021
300 85÷200 37,50 2 010320028

1033

pinze a becchi piegati a 45°
per anelli elastici di sicurezza, per fori
manici ricoperti in PVC



UNI 7914 DIN 5256

L mm	∅ mm	€		
140x0,9	8÷12	22,90	5	010330013
140x1,3	12÷25	22,40	5	010330014
180	19÷60	23,50	5	010330017
225	40÷100	29,50	3	010330021

1034

pinze a becchi piegati a 90°
per anelli elastici di sicurezza, per fori
manici ricoperti in PVC



UNI 7914 DIN 5256

L mm	∅ mm	€		
130x0,9	8÷12	22,90	5	010340013
130x1,3	12÷25	22,40	5	010340014
170	19÷60	23,50	5	010340017
210	40÷100	29,50	3	010340021
290	85÷200	40,50	2	010340028

1034L

pinza a becchi piegati a 90° lunghi
per anelli elastici di sicurezza, per fori
manici ricoperti in PVC



L mm	∅ mm	€		
190	40÷100	59,50	2	010340320

1036

pinze a becchi dritti
per anelli elastici di sicurezza per alberi
manici ricoperti in PVC



UNI 7915 DIN 5254

L mm	∅ mm	€		
140x0,9	3÷10	22,30	5	010360013
140x1,3	10÷25	21,20	5	010360014
175	19÷60	22,40	5	010360017
225	40÷100	28,50	3	010360021
300	85÷200	44,50	2	010360028

1037

pinze a becchi piegati a 45°
per anelli elastici di sicurezza per alberi
manici ricoperti in PVC



UNI 7915 DIN 5254

L mm	∅ mm	€		
140x0,9	3÷10	24,50	5	010370013
140x1,3	10÷25	23,30	5	010370014
175	19÷60	24,60	5	010370017
225	40÷100	30,50	3	010370021

1038

pinze a becchi piegati a 90°
per anelli elastici di sicurezza per alberi
manici ricoperti in PVC



UNI 7915 DIN 5254

L mm	∅ mm	€		
135x0,9	3÷10	24,50	5	010380013
135x1,3	10÷25	23,30	5	010380014
175	19÷60	24,60	5	010380017
220	40÷100	30,50	3	010380021
300	85÷200	47,50	2	010380028

1039

pinza reversibile a becchi dritti
per anelli elastici di sicurezza per fori
e alberi, manici ricoperti in PVC



L mm	∅ mm	∅ mm	€		
150	10÷15	6÷25	51,50	2	010390015

1558/C4

attrezzo per anelli seeger interni ed esterni
con azionamento a vite

grazie all'attacco quadro si applica una forza elevata
in entrambe le condizioni d'utilizzo
Puntali in dotazione:
∅ 2,5-3-3,5 mm



L mm	∅ mm	∅ mm	€		
1558/C4	5,5 ÷ 77	5,5 ÷ 77	138,00	1	015580100

330x220x50 mm - 900 g

1044

pinza regolabile
cerniera sovrapposta
manici ricoperti con 2 strati di PVC antiscivolo

· modello a nove posizioni



ISO 8976

L mm	A max mm	L1 mm	€		
250	48	39	28,50	5	010440250

1044F

pinza regolabile, fosfatata
cerniera sovrapposta
manici ricoperti in PVC

· modello a nove posizioni



ISO 8976

L mm	A max mm	L1 mm	€		
250	48	39	22,30	5	010440015

1046

pinza regolabile
cerniera a cremagliera sovrapposta
manici ricoperti in PVC

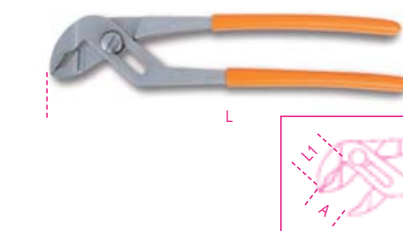

ISO 8976

L mm	A max mm	L1 mm	€		
240	28	33	32,00	5	010460240
400	107	55	55,00	1	010460400

1047

pinza regolabile a pulsante,
manici ricoperti con due strati
di PVC antiscivolo



L mm	A max mm	L1 mm	€		
180	30	29	37,00	2	010470180
240	36	35	39,50	2	010470240
300	50	48	57,00	1	010470300

1047BM

pinza regolabile a pulsante con impugnatura bimateriale

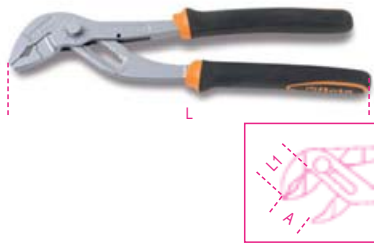

L mm	A max mm	L1 mm	€	Icon	Icon	Code
240	36	35	45,50	2	010470340	

1048

pinze regolabili cerniera chiusa manici ricoperti con 2 strati di PVC antiscivolo

· modello a nove posizioni

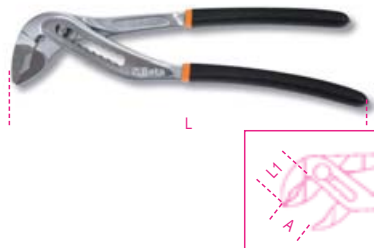

L mm	A max mm	L1 mm	€	Icon	Icon	Code
175	30	29	27,50	3	010480010	
250	48	39	30,00	5	010480015	
300	56	47	44,00	2	010480020	

1048BM

pinza regolabile a cerniera chiusa, impugnatura bimateriale

· modello a nove posizioni



L mm	A max mm	L1 mm	€	Icon	Icon	Code
250	48	39	39,00	3	010480215	

1048V

pinze regolabili verniciate arancio cerniera chiusa

· modello a nove posizioni



L mm	A max mm	L1 mm	€	Icon	Icon	Code
175	30	29	22,80	3	010480110	
250	48	39	26,50	5	010480115	
300	56	47	38,50	2	010480120	

1050

pinza autobloccante a doppia regolazione



L mm	€	Icon	Icon	Code
220	65,50	2	010500022	

1051

pinza autobloccante a doppia regolazione, ganasce lunghe

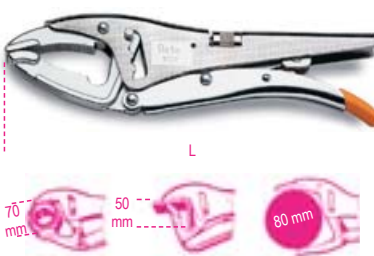

L mm	€	Icon	Icon	Code
255	71,50	2	010510025	

1051GM

pinza autobloccante a doppia regolazione, ganaschia oscillante

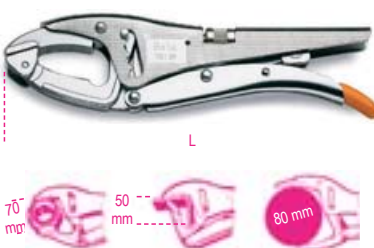

L mm	€	Icon	Icon	Code
255	75,50	2	010510250	

1051L

pinza autobloccante a doppia regolazione a grande capacità



L mm	€	Icon	Icon	Code
270	81,50	2	010510100	

1051XL

pinza autobloccante a doppia regolazione a grande capacità, ganasce extra lunghe



L mm	€	Icon	Icon	Code
270	97,50	2	010510140	

1052

pinze regolabili autobloccanti ganasce concave



L mm	A1 max mm	€	Icon	Icon	Code
140	22	21,90	3	010520014	
190	36	24,80	3	010520019	
240	42	26,50	3	010520024	
300	55	44,50	2	010520030	

1053

pinza regolabile autobloccante ganaschia oscillante

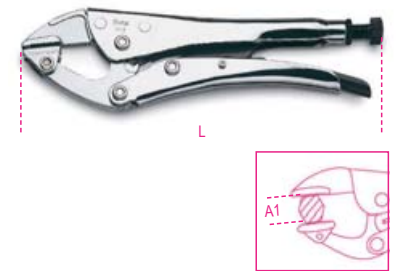

L mm	A1 max mm	€	Icon	Icon	Code
240	35	37,50	2	010530024	



1054

pinza regolabile autobloccante
ganasce diritte

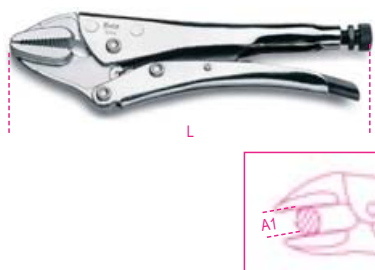

L mm	A1 max mm	€	2	010540022
235	40	32,50		

1055

pinza regolabile autobloccante
ganasce sagomate

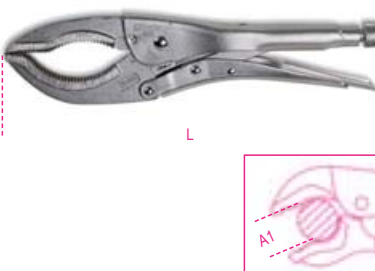

L mm	A1 max mm	€	2	010550027
270	75	29,50		

1056

pinza regolabile autobloccante
per frigoristi

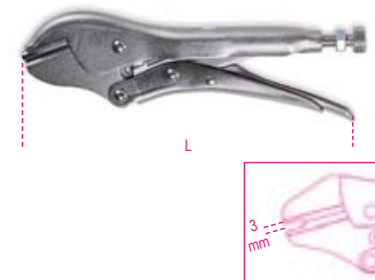

L mm	€	2	010560017
195	22,50		

1057A

pinza automatica autobloccante con
regolazione della forza



L mm	€	2	010570124
240	46,50		

1058

pinze regolabili autobloccanti
becchi lunghi

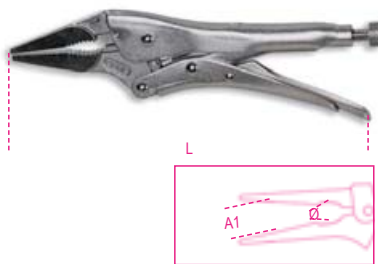

L mm	A1 max mm	Ø max mm	€	2	010580017
175	34	26	28,00		
225	46	31	33,50		

1059

pinze regolabili autobloccanti
con una ganascia parallela mobile

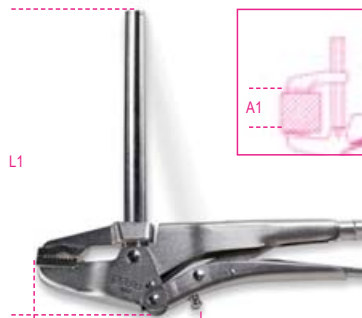

L1 mm	L mm	A1 mm	€	1	010590016
160	255	120	49,00		
270	255	220	52,00		

1060

pinze regolabili autobloccanti
ganasce a forcella

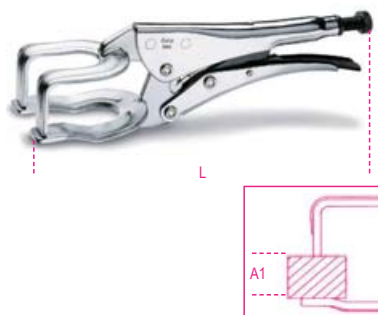

L mm	A1 max mm	€	2	010600020
200	50	35,00		
280	80	45,00		

1061

pinza regolabile autobloccante
ganasce a forcella

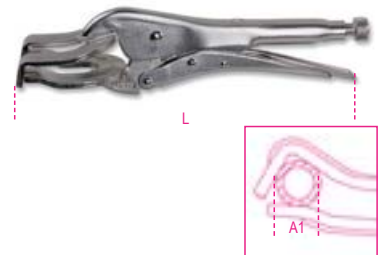

L mm	A1 max mm	€	2	010610027
275	80	38,50		

1062

pinze regolabili autobloccanti
ganasce a collo di cigno

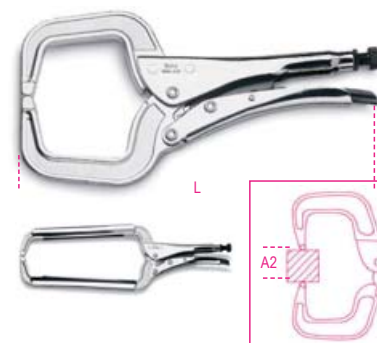

L mm	A2 max mm	€	2	010620017
170	50	27,50		
290	120	36,50		
460	255	51,50		

1062AL

pinza regolabile autobloccante
ganasce a collo di cigno
in alluminio

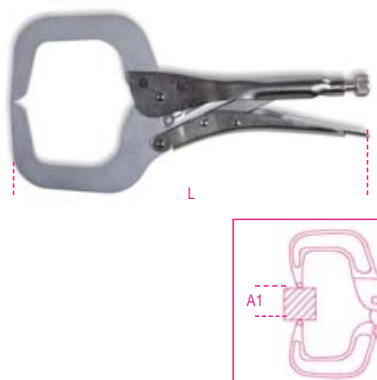

L mm	A1 max mm	€	2	010620327
275	88	48,00		

1062GM

pinze regolabili autobloccanti
ganasce a collo di cigno oscillanti

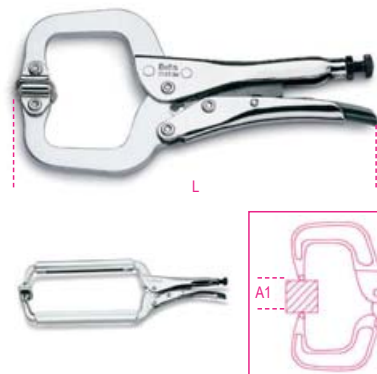

L mm	A1 max mm	€	2	010620217
170	45	30,50		
290	88	42,00		
460	255	60,00		

1063

pinza regolabile autobloccante per lattonieri

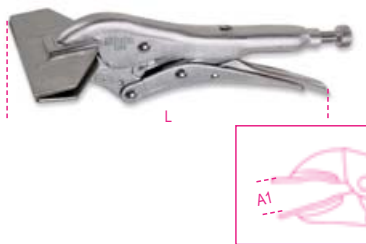

L mm	A1 max mm	€	Icon	Icon
200	31	35,50	2	010630021

1064

pinza regolabile autobloccante a catena



L mm	Ø mm	€	Icon	Icon
230	150	50,50	2	010640023

1065F

pinza foralamiera

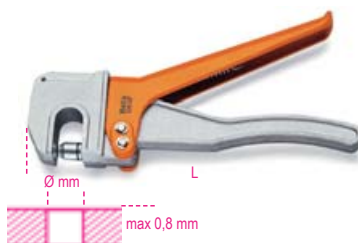

Ø mm	L mm	€	Icon	Icon
5	228	97,00	1	010650010
6	228	98,00	1	010650015

1065P

pinza piegalamiera



L mm	€	Icon	Icon
228	100,00	1	010650020

1067

pinze regolabili autobloccanti per tubolari, ganasce blocca tubo snodabili

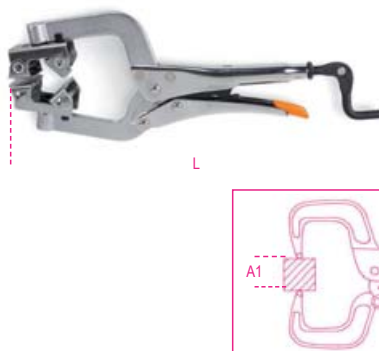

L mm	A1 max mm	€	Icon	Icon
285	76	42,50	1	010670285
380	89	44,00	1	010670380

1077

pinza a becchi larghi dritti per lattonieri manici ricoperti in PVC



L mm	A mm	L1 mm	€	Icon	Icon
280	60	53	44,00	1	010770026

1078

pinza a becchi larghi piegati a 45° per lattonieri manici ricoperti in PVC



L mm	A mm	L1 mm	€	Icon	Icon
280	60	77	45,00	1	010780026

1080D

tronchesi a taglienti diagonali rasi manici ricoperti con 2 strati di PVC antiscivolo

Per taglio di materiali plastici



α	L mm	L1 mm	€	Icon	Icon
15°	160	22	23,30	3	010800015
45°	160	22	28,50	3	010800045

1081

tronchese a tagliente semiraso manici ricoperti con 2 strati di PVC antiscivolo

• Per micromeccanica ed elettronica gravosa



L mm	L1 mm	€	Icon	Icon
125	16	24,00	3	010810130

1082

tronchesi a taglienti diagonali, cromati manici ricoperti con 2 strati di PVC antiscivolo



UNI/ISO 5749

L mm	L1 mm	mm	€	Icon	Icon
140	20	1,6	20,80	5	010820004
160	22	1,6	22,30	5	010820006

1082G

tronchesi a taglienti diagonali manici ricoperti con 2 strati di PVC antiscivolo finitura industriale



UNI/ISO 5749

L mm	L1 mm	mm	€	Icon	Icon
140	20	1,6	18,00	5	010820064
160	22	1,6	19,00	5	010820066

1082BM

tronchesi a taglienti diagonali impugnatura bimateriale



UNI/ISO 5749

L mm	L1 mm	mm	€	Icon	Icon
140	20	1,6	26,00	3	010820034
160	22	1,6	29,00	3	010820036

1082GBM

tronchesi a taglienti diagonali
impugnatura bimatereale
finitura industriale



UNI/ISO 5749

L mm	L1 mm	mm	€		
140	20	1,6	23,00	3	010820264
160	22	1,6	25,50	3	010820266

1084

tronchesi a grande effetto
a taglienti diagonali,
cromati,
manici ricoperti con 2 strati di PVC antiscivolo



UNI/ISO 5749

L mm	L1 mm	mm	€		
160	22	1,6	24,80	5	010840006
200	28	2,0	31,00	3	010840010

1084G

tronchesi a grande effetto
a taglienti diagonali, manici ricoperti
con 2 strati di PVC antiscivolo
finitura industriale



UNI/ISO 5749

L mm	L1 mm	mm	€		
160	22	1,6	21,20	5	010840066
200	28	2,0	26,50	3	010840070

1084BM

tronchesi a grande effetto
a taglienti diagonali,
cromati,
impugnatura bimatereale



UNI/ISO 5749

L mm	L1 mm	mm	€		
160	22	1,6	30,50	3	010840036
200	28	2,0	38,50	3	010840040

1084GBM

tronchesi a grande effetto
a taglienti diagonali,
impugnatura bimatereale,
finitura industriale



UNI/ISO 5749

L mm	L1 mm	mm	€		
160	22	1,6	33,00	3	010840266
200	28	2,0	42,00	3	010840270

1088

tronchesi a grande effetto
a taglienti frontali
manici ricoperti con 2 strati
di PVC antiscivolo



UNI/ISO 5748

L mm	L1 mm	mm	€		
160	9	1,6	30,50	2	010880006
200	11	2,0	39,50	2	010880010

1088BM

tronchesi a grande effetto
a taglienti frontali
impugnatura bimatereale



UNI/ISO 5748

L mm	L1 mm	mm	€		
160	9	1,6	37,00	2	010880036
200	11	2,0	50,00	2	010880040

1092V

tronchesi a doppia leva
a taglienti frontali
tipo pesante



UNI/ISO 5748

L mm	L1 mm	mm	€		
180	8	2,0	120,00	2	010920280
200	9	2,5	127,00	2	010920310

1094V

tronchese a doppia leva
taglienti diagonali
tipo pesante



UNI/ISO 5748

L mm	L1 mm	mm	€		
200	23	2,5	120,00	2	010940200

1095N

tronchese a doppia leva
a taglienti diagonali



L mm	L1 mm	mm	€		
195	26	1,6	42,50	2	010950010

1096

tenaglie per falegnami



ISO 9243

L mm	L1 mm	mm	€		
160	21		16,20	5	010960016
200	23		18,80	5	010960020
250	30		24,90	5	010960025



1098

tenaglie per cementisti



ISO 9242 DIN 5242

L	L1	€	🔧	📦
~	mm			
190	12	16,20	5	010980190
220	13	18,30	5	010980220
250	15	21,90	5	010980250
280	18	23,90	5	010980280

1098PL

tenaglie per cementisti
manici ricoperti in PVC



ISO 9242 DIN 5242

L	L1	€	🔧	📦
~	mm			
220	13	20,30	5	010980320
250	15	23,30	5	010980350
280	18	25,50	5	010980380

1101

troncabulloni



L	L	€	🔧	📦
mm	~			
300	12	48,00	2	011010030
350	14	59,00	2	011010035
450	18	72,00	1	011010045
600	24	98,50	1	011010060
750	30	127,00	1	011010075
900	36	170,00	1	011010090

L	R = 80		R = 140		g
	Kgf/mm ²	Ø mm	Kgf/mm ²	Ø mm	
300	5	4	4	4	745
350	6	5	5	5	1043
450	7	6	6	6	1537
600	9	7	7	7	2540
750	11	8	8	8	3870
900	12	9	9	9	6170

Beta

1101R

lame di ricambio per 1101



mm	1101	€	🔧	📦
300	300	29,00	1	011010130
350	350	33,50	1	011010135
450	450	42,50	1	011010145
600	600	58,00	1	011010160
750	750	71,50	1	011010175
900	900	94,00	1	011010190

1102

minitroncabulloni

R = 80 Kg/mm²



L	mm	€	🔧	📦
230	4	35,50	3	011020020

1104

tagliafuni per funi flessibili in acciaio
impugnatura in materiale plastico



L	mm	€	🔧	📦
420	12	123,50	1	011040004
600	16	180,00	1	011040006

1104R

lame di ricambio per 1104



mm	€	🔧	📦
420	76,00	1	011040014
600	106,50	1	011040016

Beta

Quality Tools

1105

fustelle in acciaio
brunite

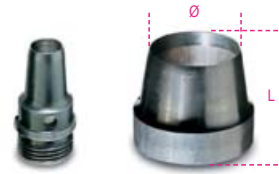

D	L	€	🔧	📦
mm	mm			
2	27	12,20	1	011050002
3	27	12,20	1	011050003
4	27	12,20	1	011050004
5	27	12,20	1	011050005
6	27	12,20	1	011050006
7	27	12,20	1	011050007
8	27	12,20	1	011050008
9	27	12,20	1	011050009
10	27	12,20	1	011050010
12	27	14,90	1	011050012
14	27	14,90	1	011050014
16	27	14,90	1	011050016
18	27	14,90	1	011050018
20	27	14,90	1	011050020
22	32	18,80	1	011050022
24	32	18,80	1	011050024
26	32	18,80	1	011050026
28	32	18,80	1	011050028
30	32	18,80	1	011050030
32	37	24,40	1	011050032
34	37	24,40	1	011050034
36	37	24,40	1	011050036
38	37	24,40	1	011050038
40	37	24,40	1	011050040
42	42	29,50	1	011050042
44	42	29,50	1	011050044
46	42	29,50	1	011050046
48	42	29,50	1	011050048
50	42	29,50	1	011050050

1105T20

battifustella per fustelle 1105
da 2 a 20 mm



L	mm	€	🔧	📦
110		61,00	1	011050200

1105T30

battifustella per fustelle 1105
da 2 a 30 mm



L	mm	€	🔧	📦
155		131,00	1	011050201



1105T50

battifustella per fustelle 1105 da 2 a 50 mm



L mm 155 € 136,00 1 011050202

1105AD-50

adattatore per battifustella 1105T50

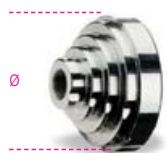

∅ mm 57 € 82,00 1 011050210

1105/C10T

assortimento di 10 fustelle da 3 a 20 mm e 1 accessorio



1105/C10T € 137,00 1 011050250

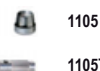

1105 3-4-6-8-10-12-14-16-18-20 mm
1105T20
325x92x32 mm

1105/C15T

assortimento di 15 fustelle da 3 a 30 mm e 1 accessorio



1105/C15T € 280,00 1 011050251



1105 3-4-6-8-10-12-14-16-18-20-22-24-26-28-30 mm
1105T30
230x190x50 mm

1105/C29T

assortimento di 29 fustelle da 2 a 50 mm e 2 accessori



1105/C29T € 504,00 1 011050252



1105 2-3-4-5-6-7-8-9-10-12-14-16-18-20-22-24-26-28-30-32-34-36-38-40-42-44-46-48-50 mm



1105T50



1105AD-50

325x280x55 mm

1112

cesoie modello americano lame larghe diritte

R = 60 Kg/mm²



L	L1	S	A	€		
mm	mm	mm	mm			
200	50	0,5	26	21,30	2	011120020
250	62	0,8	33	25,50	2	011120025
300	76	1,0	37	33,50	2	011120030
375	76	1,2	44	48,50	1	011120037

1114

cesoie modello americano lame strette diritte

R = 60 Kg/mm²

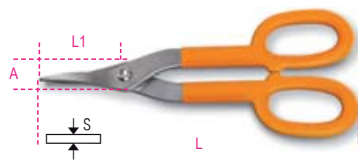

L	L1	S	A	€		
mm	mm	mm	mm			
250	58	0,5	15	22,90	1	011140265
350	76	1	22	30,50	1	011140340

1118

cesoia antinfortunistica per taglio reggia

Fe = acciaio comune

Inox = acciaio inossidabile



L	L1	Fe	Inox	€		
mm	mm	S mm	S mm			
310	42	1	0,8	37,50	2	011180001

1120A

cesoia roditrice

Fe = acciaio comune



L mm 280 € 60,50 1 011200101

1120ARL - ARG

ricambi per 1120A



1120ARL € 14,80 1 011200110
1120ARG € 18,80 1 011200120

1122

cesoia a doppia leva lame diritte

Inox = acciaio inossidabile



L mm 250 L1 mm 40 S mm 1 A mm 24 € 29,50 2 011220020

1123

cesoia a doppia leva destrorsa lame curve

Inox = acciaio inossidabile



L mm 250 L1 mm 40 S mm 1 A mm 24 € 29,50 2 011230020

1124

cesoia a doppia leva sinistrorsa lame curve

Inox = acciaio inossidabile



L mm 250 L1 mm 40 S mm 1 A mm 24 € 29,50 2 011240020

1125

cesoia a doppia leva
per tagli diritti e destrorsi
Inox = acciaio inossidabile

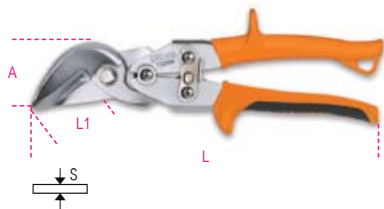

L	L1	Inox	A	€		
250	35	S mm 1	mm 46	46,00	2	011250020

1126

cesoia a doppia leva
per tagli diritti e sinistrorsi
Inox = acciaio inossidabile

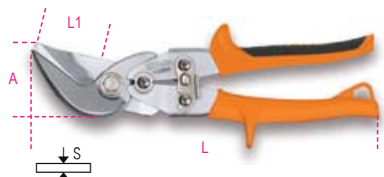

L	L1	Inox	A	€		
250	35	S mm 1	mm 46	46,00	2	011260020

1122 - 1125MOL



1122 MOL	1122 - 1124	€		
1123 MOL	1123	1,30	1	011220010
1125 MOL	1125 - 1126	1,10	1	011230010
		1,10	1	011250040

1127

forbici per telefonisti lame dritte



L	L1	€		
150	35	12,70	5	011270001

1128BAX

forbici per elettricisti a doppio effetto,
con profili a fresa in acciaio inossidabile
rivestito in DLC

taglio a doppio effetto: attraverso una speciale camma sul fulcro si ottiene uno scorrimento longitudinale delle lame che, nella fase di chiusura, ne aumenta la potenza di taglio.

profilo e fresa: studiate per allargare fori su plastica da 13 a 25 mm.

rivestimento DLC: Il DLC (diamond-like carbon) è un rivestimento innovativo a base di carbonio: l'elevata durezza ed il basso coefficiente d'attrito nascono dalla simultanea presenza di carbonio depositato sulla superficie in forma di grafite e diamante.

- alta durezza superficiale delle lame (resistenza all'abrasione e mantenimento dell'affilatura nel tempo)
- basso coefficiente di attrito (scorrevolezza e potenza di taglio)
- perno eccentrico anti-allentamento
- manici ampi con gole strozzatubi

BREVETTATO



L	L1	€		
mm 150	mm 50	28,50	5	011280088

1128BCX

forbici per elettricisti
lame dritte in acciaio inossidabile
con microdentatura, gola tranciavo e
crimpatore per terminali a tubetto

con custodia plastica snodata



L	L1	€		
mm 155	mm 55	24,00	5	011280080

1128BMX

forbici per elettricisti
lame dritte in acciaio inossidabile
con microdentatura



L	L1	€		
mm 147	mm 58,2	14,80	5	011280051

1128BMX/F

custodia snodata in plastica
per 1128BMX



1128BMX/F	€		
	1,50	1	011280059

1128BSX

forbici per elettricisti con svasatore
lame dritte in acciaio inossidabile

studiate per allargare fori su plastica
e chiudere tubi corrugati
• con custodia plastica snodata

BREVETTATO



L	L1	€		
mm 148	mm 58,2	25,50	5	011280061

1128FX

forbici per elettricisti
lame dritte in acciaio inossidabile
con microdentatura, gola tranciavo e
crimpatore per terminali a tubetto.

- Custodia agganciabile alla cintura
- Impugnatura bimateriale
- Perno anti-allentamento



L	L1	€		
mm 145	mm 52	27,50	5	011280090

Beta
Quality Tools



1128FXS

forbici per elettricisti con svasatore
lame in acciaio inossidabile
con microdentatura, gola tranciavo e
crimpatore per terminali a tubetto.

- Custodia agganciabile alla cintura
- Impugnatura bimatereale
- Perno anti-allentamento
- profilo e fresa: studiate per allargare fori su plastica da 13 a 21 mm.

BREVETTATO



L	L1	mm	mm ²	€	1	011280095
145	52	50		32,50	5	

1128BM

forbici per elettricisti
lame dritte



L	L1	mm	mm	€	5	011280000
145	50			13,00	5	

1129BM

forbici per elettricisti
lame curve



L	L1	mm	mm	€	5	011290000
145	44			13,90	5	

1130BMX

forbici multiuso
lame dritte in acciaio inossidabile
con microdentatura



L	L1	mm	mm	€	1	011300002
185	60			16,80	1	

1131CK

forbici per Kevlar® e fibre ottiche

in acciaio specificatamente studiato per operare su materiali
antitaglio come fibre aramidiche
Anche per fibre ottiche



L	L1	mm	mm	€	1	011310001
203	75			67,50	1	

1132

tagliacavi
manici ricoperti con 2 strati
di PVC antiscivolo per taglio di cavi isolati
di rame e alluminio



UNI 8791

L	mm	mm ²	€	2	011320107
170	14	50	40,50	2	
230	18	95	50,00	2	011320113

1132BM

tagliacavi
impugnature bimatereale
per cavi isolati in rame e alluminio



UNI 8791

L	mm	mm ²	€	2	011320137
170	14	50	50,00	2	
230	18	95	62,00	2	011320143

1133

tagliacavi
per cavi in rame flessibile



L	mm	mm ²	€	1	011330001
600	32	300	140,00	1	

1133RL

lame di ricambio per 1133



1133RL	€	1	011330011
	105,00	1	

1134

tagliacavi a cricchetto



L	mm	mm	mm ²	€	1	011340032
260	35	400		408,00	1	

1134RL

lama di ricambio per 1134



1134RL	€	1	011340132
	185,00	1	

1134A

tagliacavi a cricchetto



L	mm	mm	mm ²	€	1	011340045
240	45	500		620,00	1	

1134A/RL

lama di ricambio per 1134A



1134A/RL	€	1	011340145
	285,00	1	

1136

tagliacavi per cavi di acciaio

Ø 5 mm per cavi con R ≤ 160 Kg/mm²
Ø 4 mm per bulloni in acciaio dolce



L	mm	€	2	011360001
165		47,50	2	

1142BM

pinza spellafili
impugnatura bimateriale



UNI 7923

L mm	mm ²	mm	€		
160	0,5÷6	0-2,8	33,50	3	011420036

1143

pinza spellafili



L mm	mm ²	mm	€		
165	1÷6	1-3,2	65,50	1	011430001

1143R

lame di ricambio per 1143

1143R	€		
	16,50	1	011430011

1144D

spellacavi con lama regolabile per tagli
trasversali e longitudinali



L mm	mm ²	mm	€		
170	4,5÷240	2,5-18	78,50	1	011440010

1144D/RG

gancio di ricambio per 1144D



1144D/RG	€		
	26,00	1	011440012

1144D/RL

lame di ricambio per 1144D

1144D/RL	€		
	40,00	1	011440011



1144G

spellacavi con lama regolabile per tagli
trasversali e longitudinali



L mm	mm ²	mm	€		
140	6÷75	2,8-12	44,00	1	011440004

1144G/RL

lama di ricambio per 1144G



1144G/RL	€		
	9,50	1	011440005

1144L

spellacavi con lama regolabile per tagli
trasversali e longitudinali

con lama retrattile liscia ed a uncino



L mm	mm ²	mm	€		
145	6-150	4-28	25,00	1	011440050

1148A

pinza spellafili autoregolabile
con dispositivo di taglio



L mm	mm ²	mm	€		
190	0,02÷10	0-4	134,00	1	011480100

1148A/R

lame di ricambio per 1148A



1148A/R	€		
	58,00	1	011480102

1148B

pinza spellafili autoregolabile
con dispositivo di taglio



L mm	mm ²	mm	€		
190	4÷16	2-5	157,00	1	011480200

1148B/R

lame di ricambio per 1148B



1148B/R	€		
	72,00	1	011480202

1148P

pinza spellafili autoregolabile con dispositivo
di taglio



L mm	mm ²	mm	€		
165	0,2-6	0-3,5	38,00	1	011480300

1149F

pinza spellafili frontale autoregolabile,
con dispositivo di taglio



L mm	mm ²		€		
175	0,2 ÷ 6		14,50	1	011490010



1150

pinze universali a **grande effetto**,
cromate
manici ricoperti con 2 strati
di PVC antiscivolo



ISO 5746

L mm	L1 mm	mm	€		
160	42	1,6	18,50	5	011500046
180	46	1,8	20,20	5	011500048
200	50	2,0	22,20	5	011500050
220	50	2,0	24,00	2	011500052

1150G

pinze universali a **grande effetto**
manici ricoperti con 2 strati di PVC antiscivolo
finitura industriale



ISO 5746

L mm	L1 mm	mm	€		
160	42	1,6	17,40	5	011500066
180	46	1,8	18,90	5	011500068
200	50	2,0	20,80	5	011500070
220	50	2,0	22,30	2	011500072

1150HPC

pinza universale a **grande effetto**
con tagliente a inserto, perno decentrato,
cromata perlata, impugnatura bi-materiale,
cassetta aperta

tagliente a inserto
acciaio: M2
spessore: 0.20 mm
angolo: 62°
durezza: 65 HRC



ISO 5746

L mm	L1 mm	mm	€		
180	42	1,8	49,50	2	011500618

1150BM

pinze universali a **grande effetto**,
cromate
impugnatura bimatereale



ISO 5746

L mm	L1 mm	mm	€		
160	42	1,6	23,00	3	011500146
180	46	1,8	24,90	3	011500148
200	50	2,0	28,00	3	011500150
220	50	2,0	30,00	2	011500152

1150GBM

pinze universali a **grande effetto**
impugnatura bimatereale
finitura industriale



ISO 5746

L mm	L1 mm	mm	€		
160	42	1,6	21,50	3	011500266
180	39	1,8	23,00	3	011500268
200	50	2,0	26,00	3	011500270
220	50	2,0	28,00	2	011500272

1153

pinza regolabile a due posizioni
manici ricoperti con 2 strati
di PVC antiscivolo



UNI ISO 9343

L mm	L1 mm	mm	€		
200	34		21,00	2	011530120

1162

pinze a becchi piatti
lungheissimi diritti zigrinati,
cromate,
manici ricoperti con 2 strati di PVC antiscivolo



ISO 5745

L mm	L1 mm	mm	€		
160	58	1,6	21,80	5	011620006
200	86	1,6	24,90	5	011620010

1162G

pinze a becchi piatti
lungheissimi diritti zigrinati,
manici ricoperti con 2 strati di PVC antiscivolo
finitura industriale



ISO 5745

L mm	L1 mm	mm	€		
160	58	1,6	18,50	5	011620066
200	86	1,6	21,50	5	011620070

1162BM

pinze a becchi piatti
lungheissimi diritti zigrinati,
cromate,
impugnatura bimatereale



ISO 5745

L mm	L1 mm	mm	€		
160	58	1,6	26,50	3	011620036
200	86	1,6	30,50	3	011620040

1162GBM

pinze a becchi piatti
lungheissimi diritti zigrinati,
impugnatura bimatereale
finitura industriale



ISO 5745

L mm	L1 mm	mm	€		
160	58	1,6	23,00	3	011620266
200	86	1,6	27,00	3	011620270

1164

pinze a becchi piatti
lungheissimi piegati zigrinati
manici ricoperti con 2 strati
di PVC antiscivolo



ISO 5745

L mm	L1 mm	mm	€		
160	54	1,6	23,80	5	011640006
200	76	1,6	26,50	5	011640010



1164BM

pinze a becchi piatti
lunghissimi piegati zigrinati
impugnatura bimatereale



ISO 5745

L mm	L1 mm	mm	€		
160	54	1,6	29,00	3	011640036
200	76	1,6	33,00	3	011640040

1166

pinze a becchi mezzotondi lunghissimi
diritti zigrinati,
cromate,
manici ricoperti con 2 strati di PVC antiscivolo



ISO 5745

L mm	L1 mm	mm	€		
160	56	1,6	21,80	5	011660006
200	76	1,6	24,90	5	011660010

1166G

pinze a becchi mezzotondi lunghissimi
diritti zigrinati
manici ricoperti con 2 strati
di PVC antiscivolo
finitura industriale



INDUSTRIAL FINISHING

ISO 5745

L mm	L1 mm	mm	€		
160	56	1,6	18,50	5	011660066
200	76	1,6	21,50	5	011660070

1166BM

pinze a becchi mezzotondi lunghissimi
diritti zigrinati,
cromate,
impugnatura bimatereale



ISO 5745

L mm	L1 mm	mm	€		
160	56	1,6	26,50	3	011660036
200	76	1,6	30,50	3	011660040

1166GBM

pinze a becchi mezzotondi lunghissimi
diritti zigrinati
impugnatura bimatereale
finitura industriale



INDUSTRIAL FINISHING

ISO 5745

L mm	L1 mm	mm	€		
160	56	1,6	23,00	3	011660266
200	76	1,6	27,00	3	011660270

1168

pinze a becchi mezzotondi lunghissimi
piegati zigrinati,
cromate,
manici ricoperti con 2 strati di PVC antiscivolo



ISO 5745

L mm	L1 mm	mm	€		
160	54	1,6	23,80	5	011680006
200	76	1,6	26,50	5	011680010

1168G

pinze a becchi mezzotondi lunghissimi
piegati zigrinati,
manici ricoperti con 2 strati di PVC antiscivolo
finitura industriale



INDUSTRIAL FINISHING

ISO 5745

L mm	L1 mm	mm	€		
160	54	1,6	20,20	5	011680066
200	76	1,6	22,80	5	011680070

1168BM

pinze a becchi mezzotondi lunghissimi
piegati zigrinati,
cromate,
impugnatura bimatereale



ISO 5745

L mm	L1 mm	mm	€		
160	54	1,6	29,00	3	011680036
200	70	1,6	33,00	3	011680040

1168GBM

pinze a becchi mezzotondi lunghissimi
piegati zigrinati,
impugnatura bimatereale
finitura industriale



INDUSTRIAL FINISHING

ISO 5745

L mm	L1 mm	mm	€		
160	54	1,6	25,50	3	011680266
200	70	1,6	29,50	3	011680270

1169/D3

assortimento di 1 pinza universale,
1 pinza becchi mezzotondi lunghi
e 1 tronchese, con 2 strati di PVC
antiscivolo
cromati



	€		
1169/D3	64,50	1	011690053
1082 160mm			
1150 180mm			
1166 160mm			

1169G/D3

assortimento di 1 pinza universale,
1 pinza becchi mezzotondi lunghi
e 1 tronchese, con 2 strati di PVC
antiscivolo
con **finitura industriale**



INDUSTRIAL FINISHING

	€		
1169G/D3	56,50	1	011690073
1082G 160mm			
1150G 180mm			
1166G 160mm			

1169BM/D3

assortimento di 1 pinza universale,
1 pinza becchi mezzotondi lunghi
e 1 tronchese, **impugnatura bimatériale cromati**



1169BM/D3	€ 80,00	1	011690133
1082BM 160mm			
1150BM 180mm			
1166BM 160mm			

1169GBM/D3

assortimento di 1 pinza universale,
1 pinza becchi mezzotondi lunghi
e 1 tronchese, **impugnatura bimatériale, con finitura industriale**



1169GBM/D3	€ 71,50	1	011690273
1082GBM 160mm			
1150GBM 180mm			
1166GBM 160mm			

1171BM

pinza per elettronica
a becchi piatti corti lisci
impugnatura bimatériale



ISO 9655

L	L1	A	B	€		
~	mm	mm	mm			
130	18	12	8	36,50	2	011710101

1172BM

pinza per elettronica
a becchi piatti lunghi lisci
impugnatura bimatériale

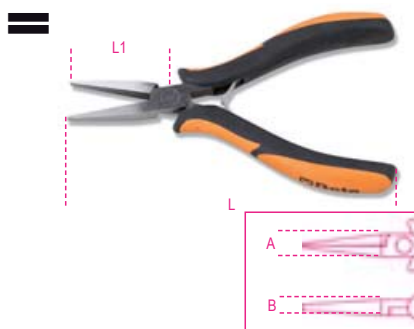

ISO 9655

L	L1	A	B	€		
~	mm	mm	mm			
140	40	12	8	36,50	2	011720101

1172BM/P

pinza per elettronica
a becchi piatti lunghi piegati lisci
impugnatura bimatériale



L	L1	A	B	€		
~	mm	mm	mm			
140	38	12	13	41,50	2	011720102

1173BM

pinza per elettronica
a becchi tondi corti
impugnatura bimatériale



ISO 9655

L	L1	A	B	€		
~	mm	mm	mm			
125	22	12	8	36,50	2	011730101

1175BM

pinza per elettronica
a becchi mezzotondi corti lisci
impugnatura bimatériale



ISO 9655

L	L1	A	B	€		
~	mm	mm	mm			
140	29	12	8	36,50	2	011750101

1177BM

pinza per elettronica
a becchi mezzotondi lunghi lisci
impugnatura bimatériale



ISO 9655

L	L1	A	B	€		
~	mm	mm	mm			
140	38	12	8	36,50	2	011770101

1177BM/Z

pinza per elettronica
a becchi mezzotondi lunghi zigrinati
impugnatura bimatériale



ISO 9655

L	L1	A	B	€		
~	mm	mm	mm			
140	39	12	8	41,50	2	011770113

1178BM

pinza per elettronica
a becchi mezzotondi lunghi lisci rastremati
impugnatura bimatériale

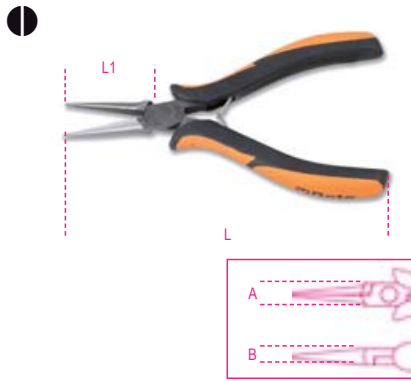

ISO 9655

L	L1	A	B	€	Impugnatura	Art. No.
mm	mm	mm	mm			
140	37	12	8	41,50	2	011780101

1178BM/P

pinza per elettronica
a becchi mezzotondi lunghi lisci rastremati
piegati
impugnatura bimatériale



L	L1	A	B	€	Impugnatura	Art. No.
mm	mm	mm	mm			
140	36,5	12	12	41,50	2	011780102



Seguono tronchesi per rame.
Per usi piú gravosi vedere l'articolo 1081

1182BM

tronchesi per elettronica
a taglienti diagonali semirasi
becchi assottigliati
impugnatura bimatériale



ISO 9654

L	L1	A	Cu	€	Impugnatura	Art. No.
mm	mm	mm	mm			
120	11	10	1	41,50	2	011820101

1183BM

tronchesi per elettronica
a taglienti diagonali semirasi
becchi arrotondati
impugnatura bimatériale



ISO 9654

L	L1	A	Cu	€	Impugnatura	Art. No.
mm	mm	mm	mm			
120	11	10	1	41,50	2	011830101

1184BM

tronchesi per elettronica
a taglienti diagonali rasi
becchi arrotondati
impugnatura bimatériale



ISO 9654

L	L1	A	Cu	€	Impugnatura	Art. No.
mm	mm	mm	mm			
120	11	10	1	41,50	2	011840101
130	13	12,5	1,25	41,50	2	011840102

1185BM

tronchesi per elettronica
a taglienti diagonali rasi
becchi assottigliati
impugnatura bimatériale



ISO 9654

L	L1	A	Cu	€	Impugnatura	Art. No.
mm	mm	mm	mm			
120	11	10	1	41,50	2	011850101
130	13	12,5	1,25	41,50	2	011850102

1186BM

tronchesi per elettronica
a taglienti diagonali rasi
becchi assottigliati scaricati
impugnatura bimatériale



ISO 9654

L	L1	A	Cu	€	Impugnatura	Art. No.
mm	mm	mm	mm			
120	11	10	1	41,50	2	011860101
130	13	12,5	1,25	41,50	2	011860102



1188BM

tronchese per elettronica
a taglienti diagonali normali
impugnatura bimateriale



ISO 9654

L mm	L1 mm	A mm	Cu mm	€		
125	12	12	1,25	41,50	2	011880101
130	17	15	2	41,50	2	011880102

1190BM

tronchese per elettronica
a taglienti frontali normali
impugnatura bimateriale



ISO 9654

L mm	L1 mm	A mm	Cu mm	€		
120	12	12	1,25	41,50	2	011900113

1191BM

tronchese per elettronica
a taglienti obliqui rasi
becchi lunghi sottili
impugnatura bimateriale



ISO 9654

L mm	L1 mm	A mm	Cu mm	€		
130	8	12	0,8	41,50	2	011910101

1191BM/L

tronchese per elettronica
a taglienti obliqui rasi e spellafilo
impugnatura bimateriale



ISO 9654

L mm	L1 mm	A mm	Cu mm	€		
130	18	12	1	41,50	2	011910110

1191R/5-M

kit molle di ricambio per pinze e tronchesi per
elettronica, 5 coppie (Artt.: 1171...1191)

1191R/5-M	€		
	8,20	1	011910995

1200MS

magnetizzatore-smagnetizzatore

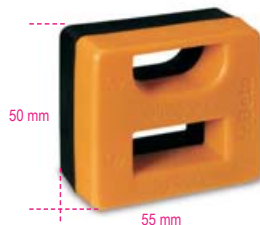

1200MS	€		
	13,40	5	012000000



1201E

giravite per viti
a testa con intaglio



SxAxL mm	L1 mm	Ø mm	€		
0,4x2,5x50	146	2,5	3,35	5	012011003
0,4x2,5x75	166	2,5	3,45	5	012011006
0,5x3x75	171	3,0	3,50	5	012011009
0,5x3x100	196	3,0	3,75	5	012011012
0,6x3,5x75	171	3,5	3,75	5	012011018
0,6x3,5x100	196	3,5	3,85	5	012011021
0,8x4x100	196	4,0	3,90	5	012011030
0,8x4x125	221	4,0	4,10	5	012011033
0,8x4x150	246	4,0	4,50	5	012011036
1,0x5,5x100	209	5,0	4,80	5	012011039
1,0x5,5x125	234	5,0	5,10	5	012011040
1,0x5,5x150	259	5,0	5,20	5	012011042
1,2x6,5x100	220	6,0	5,80	5	012011048
1,2x6,5x125	234	6,0	6,00	5	012011050
1,2x6,5x150	270	6,0	6,10	5	012011051
1,2x8x150	282	8,0	7,90	3	012011057
1,2x8x200	332	8,0	8,50	3	012011060
1,6x10x200	332	9,5	9,70	3	012011066



1201E/S6	€		
0,5x3x75-0,6x3,5x100 0,8x4x100-1,0x5,5x100 1,2x8x150-1,6x10x200 mm	33,50	1	012011206

1201EN

giravite per viti a testa con intaglio
tipo cortissimo



SxAxL mm	L1 mm	Ø mm	€		
0,8x4x30	86,5	4	4,70	3	012011103
1,2x6,5x30	86,5	6 51	5,00	3	012011106

1201E/DZ

giravite per viti con impronta Dzus®



L mm	L1 mm	€		
53	173	11,50	2	012011501

1202E

giravite per viti
con impronta a croce Phillips®



PHxDxL mm	L1 mm	€	Icon	Icon	Icon
0x3x60	156	3,45	5	012021003	
0x3x100	200	3,85	5	012021006	
1x4,5x80	189	4,45	5	012021009	
1x4,5x120	229	4,95	5	012021012	
2x6x100	220	6,00	5	012021018	
2x6x150	270	6,45	5	012021021	
3x8x150	282	8,30	3	012021024	
4x9,5x200	332	10,80	3	012021027	



€	Icon	Icon	Icon
23,20	1	012021204	

1202E/S4
PH0x3x60-PH1x4,5x120
PH2x6x150-PH3x8x150 mm

1202EN

giravite per viti con impronta
a croce Phillips®
tipo cortissimo



PHxDxL mm	L1 mm	€	Icon	Icon	Icon
1x4,5x30	86,5	4,70	3	012021103	
2x6x30	86,5	5,00	3	012021106	

1202EL

giravite per viti con impronta
a croce Phillips®, tipo lungo



PHxDxL mm	L1 mm	€	Icon	Icon	Icon
0x3x300	400	6,10	3	012021303	
1x4,5x300	400	6,70	3	012021305	
1x4,5x400	508	8,20	3	012021306	
2x6x400	519	9,40	3	012021309	

1203E/D

serie giravite



€	Icon	Icon	Icon
25,50	1	012031001	

1201E	0,6x3,5x100-1,0x5,5x150 1,2x6,5x150 mm
1202E	PH1x4,5x80-PH2x6x100 mm

€	Icon	Icon	Icon
24,70	1	012031003	

1201E	0,5x3x75-0,8x4x125 1,0x5,5x150 mm
1209E/PZ	PZ1x4,5x80-PZ2x6x100 mm

€	Icon	Icon	Icon
26,50	1	012031006	

1202E	PH1x4,5x80-PH2x6x100 mm
1204E	0,4x2,5x60-0,5x3x100 0,8x4x100-1,0x5x125 mm

€	Icon	Icon	Icon
32,00	1	012031007	

1201E	0,5x3x75-0,8x4x100 1,0x5,5x100-1,2x6,5x150 mm
1202E	PH0x3x60-PH1x4,5x80 PH2x6x100 mm

€	Icon	Icon	Icon
41,00	1	012031008	

1201E	0,5x3x75-0,8x4x125 1,0x5,5x150-1,2x6,5x150 mm
1202E	PH0x3x60-PH1x4,5x80 PH2x6x100-PH3x8x150 mm

€	Icon	Icon	Icon
51,50	1	012031010	

1201E	0,4x2,5x50-0,5x3x75 0,8x4x100-1,0x5,5x100 1,2x6,5x150-1,2x8x150 mm
1202E	PH0x3x60-PH1x4,5x80 PH2x6x100-PH3x8x150 mm

€	Icon	Icon	Icon
45,50	1	012031019	

1201E	0,4x2,5x50-0,5x3x75-0,8x4x100- 1,0x5,5x150-1,2x6,5x150 mm
1201EN	0,8x4x30 mm
1202E	PH0x3x60-PH1x4,5x80- PH2x6x100 mm
1202EN	PH1x4,5x30 mm



1203E/S



€	Icon	Icon	Icon
36,00	1	012031009	

1201E	2,5x50-3x75-4x100-5,5x125- 6,5x150 mm
1202E	PH0x3x60-PH1x4,5x80- PH2x6x100 mm

€	Icon	Icon	Icon
52,50	1	012031021	

1201E	0,4x2,5x50-0,5x3x75 0,8x4x125-1,0x5,5x150 1,2x6,5x150-1,2x8x150 mm
1202E	PH0x3x60-PH1x4,5x80 PH2x6x100-PH3x8x150 mm

1204E

giravite per viti senza testa
con intaglio



SxDxL mm	L1 mm	€	Icon	Icon	Icon
0,4x2,5x60	156	3,40	5	012041003	
0,6x3x75	175	3,50	5	012041006	
0,5x3x100	196	3,60	5	012041009	
0,8x4x100	196	4,00	5	012041012	
0,8x4x125	233	4,20	5	012041015	
1x5x125	234	4,85	5	012041018	
1x5x150	258	5,35	5	012041021	
1,2x6,5x150	270	5,80	5	012041024	



€	Icon	Icon	Icon
21,70	1	012041205	

1204E/S5	0,4x2,5x60-0,5x3x100 0,8x4x100-1x5x125 1,2x6,5x150 mm
----------	---

1204EL

giravite per viti senza testa con intaglio tipo lungo

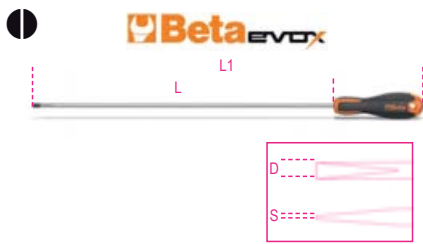

SxDxL mm	L1 mm	€		
0,5x2,5x200	300	5,00	3	012041303
0,5x3x300	400	6,00	3	012041306
0,8x4x400	508	7,40	3	012041309
1x5x400	508	7,90	3	012041315
1,2x6,5x400	519	10,00	3	012041318

1205E/ES

chiavi maschio esagonale con impugnatura



mm	L mm	L1 mm	€		
1,5	100	200	4,30	3	012051315
2	100	200	4,45	3	012051320
2,5	100	200	4,50	3	012051325
3	100	200	4,60	3	012051330
4	100	208	5,30	3	012051340
5	100	219	6,30	3	012051350
6	125	244	6,50	3	012051360
8	150	277	8,70	2	012051380



1205E/ES-S8	44,50	1	012051408
1,5-2-2,5-3-4-5-6-8 mm			

1206E/BP

chiavi maschio esagonale ad estremità sferica con impugnatura



mm	L mm	L1 mm	Ø mm	€		
2	100	198	2,5	4,75	3	012061320
2,5	100	198	3,0	4,80	3	012061325
3	100	198	3,5	4,90	3	012061330
4	100	209	5,0	5,60	3	012061340
5	100	220	6,0	6,70	3	012061350
6	125	245	7,0	6,90	3	012061360
8	150	287	9,5	9,20	2	012061380



1206E/BP-S7	43,00	1	012061407
2-2,5-3-4-5-6-8 mm			

1207E/TX

chiavi maschio con impugnatura per viti con impronta Torx®

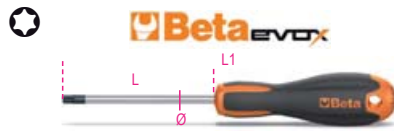

	L mm	L1 mm	Ø mm	€		
T5	50	150	3	5,10	5	012071005
T6	60	156	4	5,45	5	012071006
T7	60	156	4	5,60	5	012071007
T8	60	156	4	5,70	5	012071008
T9	60	156	4	5,90	5	012071009
T10	80	189	5	6,70	5	012071010
T15	80	189	5	6,80	5	012071015
T20	100	209	5	6,90	5	012071020
T25	100	209	5	7,10	5	012071025
T27	100	220	6	7,50	5	012071027
T30	100	220	6	7,60	5	012071030
T40	130	262	7	9,00	2	012071040
T45	130	262	8	9,80	2	012071045



1207E/TX-D7	46,00	1	012071207
T6-T8-T10-T15			
T20-T25-T30			
1207E/TX-D13	89,00	1	012071213
T5-T6-T7-T8-T9-T10-T15			
T20-T25-T27-T30-T40-T45			

1208E/RTX

chiavi maschio con impugnatura per viti con impronta Tamper Resistant Torx®



	L mm	L1 mm	Ø mm	€		
T9	60	156	4	6,00	5	012081009
T10	80	189	5	6,70	5	012081010
T15	80	189	5	7,10	5	012081015
T20	100	209	5	7,20	5	012081020
T25	100	209	5	7,40	5	012081025
T27	100	220	6	8,00	5	012081027
T30	100	220	6	8,40	5	012081030
T40	130	262	7	9,90	2	012081040



1208E/RTX-D7	51,00	1	012081207
T9-T10-T15-T20			
T25-T27-T30			

1209E/PZ

giravite per viti con impronta a croce Pozidriv®-Supadriv®



PZ	L mm	L1 mm	€		
0	60	156	4,00	5	012091000
1	80	189	5,20	5	012091003
2	100	220	6,70	5	012091006
3	150	282	10,20	3	012091009
4	200	327	11,30	3	012091012



1209E/PZ-S4	26,00	1	012091204
PZ0-PZ1-PZ2-PZ3			

1209EN/PZ

giravite per viti con impronta a croce Pozidriv®-Supadriv® tipo cortissimo



PZ	L mm	L1 mm	€		
1	30	87	4,70	3	012091103
2	30	87	5,00	3	012091106



1229LP

microgiravite per viti senza testa con intaglio

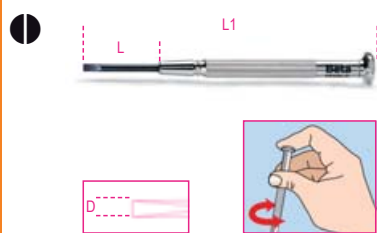

D mm	L mm	L1 mm	€	🔧	📦
1,0	17	75	3,50	5	012290210
1,2	21	85	3,50	5	012290212
1,4	21	89	3,50	5	012290214
1,8	23	94	3,50	5	012290218
2,0	23	98	3,50	5	012290220
2,4	26	103	3,50	5	012290224
3,0	28	108	4,20	5	012290230



1229LP/A6	€	🔧	📦
1,2-1,4-1,8-2-2,4-3 mm	21,00	5	012290300

1229PH

microgiravite per viti con impronta a croce Phillips®

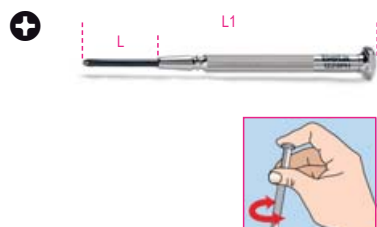

PH	L mm	L1 mm	€	🔧	📦
0	26	102	3,90	5	012290250
1	29	107	4,10	5	012290251

1229LPH/A6

serie di 6 microgiravite
1229LP - 1229PH



1229LPH/A6	€	🔧	📦
1229LP 1,4-2,0-2,4-3 mm	21,00	5	012290310
1229PH PH0-PH1		5	

1236B

giravite a squadra per viti a testa con intaglio



UNI 7079 DIN 5200

SxA mm	L mm	€	🔧	📦
0,8x4	100	6,00	5	012360201
1x5,5	125	7,00	5	012360202
1,2x8	150	8,70	5	012360204

1238B

giravite a squadra per viti con impronta a croce Phillips®



UNI 7083 DIN 5208

PH	L mm	€	🔧	📦
1-2	125	7,10	5	012380201
3-4	200	11,60	5	012380203

1241

giravite a battere per viti a testa con intaglio

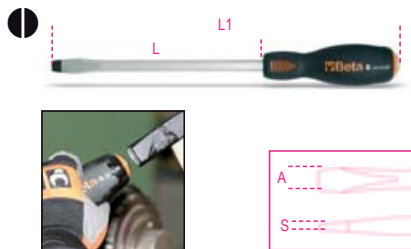

ISO 2380

SxAxL mm	L1 mm	€	🔧	📦
1x5,5x100	202	9,30	5	012410039
1,2x6,5x125	240	10,40	5	012410050
1,2x8x150	268	12,60	3	012410057
1,6x10x200	325	16,20	2	012410066

1242

giravite a battere per viti con impronta a croce Phillips®



UNI/ISO 8764

PHxDxL mm	L1 mm	€	🔧	📦
1x4,5x100	202	9,20	5	012420209
2x6x100	215	10,90	5	012420218
3x8x150	268	14,00	3	012420221
4x11x200	325	18,20	2	012420224

1243/D7

serie di 7 giravite a battere



1243/D7	€	🔧	📦
1241 1x5,5x100-1,2x6,5x125 1,2x8x150-1,6x10x200 mm	82,50	5	012430017
1242 PH1x4,5x100-PH2x6x100 PH3x8x150 mm		5	

1250

giravite prensili per viti a testa con intaglio

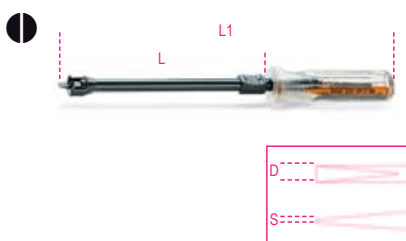

SxDxL mm	L1 mm	€	🔧	📦
0,5x3x125	190	13,30	5	012500030
0,6x4x125	225	14,30	5	012500040
0,7x5x150	255	16,90	5	012500050

1251

giravite prensili per viti con impronta a croce Phillips®

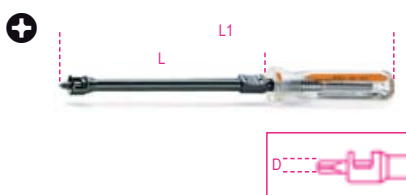

PHxDxL mm	L1 mm	€	🔧	📦
0x4x125	225	14,80	5	012510000
1x5x150	255	17,40	5	012510010
2x6x175	280	20,00	5	012510020

1252/S5

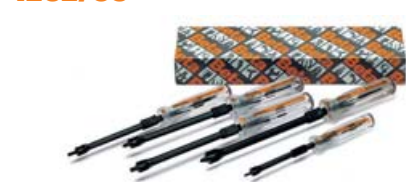

1252/S5	€	🔧	📦
1250 0,5x3x125-0,6x4x125 0,7x5x150 mm	82,00	5	012520001
1251 PH1x5x150-PH2x6x175 mm		5	

1253

giravite cercafase 150/250V

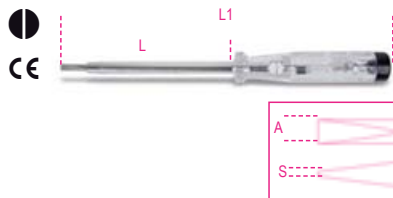

SxAxL mm	L1 mm	€	🔧	📦	012530001
0,5x3,5x100	190	8,00	5		

1253A

giravite cercafase 125/250V
doppio isolamento



SxAxL mm	L1 mm	€	🔧	📦	012530010
0,5x3x15	150	5,70	5		

1254

giravite provacircuito 6÷24V

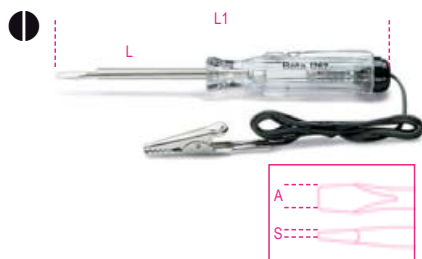

SxAxL mm	L1 mm	€	🔧	📦	012540001
0,5x3x44	123	8,80	5		

1256/C36-2

microgiravite con 36 inserti intercambiabili
da 4 mm e prolunga magnetica



1256/C36-2	€	🔧	📦	012560100
	57,00	1		

	1256TX	T3 - T4 - T5 - T6 - T7 T8 - T9 - T10 - T15
	1256RTX	T6 - T7 - T8 - T9 - T10
	1256LP	0,8 - 1,2 - 1,5 - 1,8 - 2 - 2,5 3 - 3,5 - 4 mm
	1256PE	0,7 - 0,9 - 1,3 - 1,5 - 2 mm
	1256PH	PH000 - PH00 - PH0 - PH1
	1256PZ	PZ000 - PZ00 - PZ0 - PZ1
	1256/20	
	1256/30	
📏 130x60x35 mm - 📦 200 g		

1256LP

inserti 4 mm
per viti a testa con intaglio

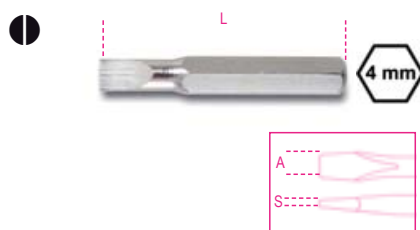

SxA mm	L mm	€	🔧	📦	012560001
0.25x0.8	27	1,10	5		
0.25x1.2	27	1,10	5		
0.3x1.5	27	1,10	5		
0.35x1.8	27	1,10	5		
0.4x2.0	27	1,10	5		
0.4x2.5	27	1,10	5		
0.5x3.0	27	1,10	5		
0.6x3.5	27	1,10	5		
0.8x4.0	27	1,10	5		

1256PH

inserti 4 mm
per viti con impronta Phillips®



PH	L mm	€	🔧	📦	012560011
000	27	1,10	5		
00	27	1,10	5		
0	27	1,10	5		
1	27	1,10	5		

1256PZ

inserti 4 mm
per viti con impronta Pozidriv® - Supradriv®



PZ	L mm	€	🔧	📦	012560061
000	27	1,10	5		
00	27	1,10	5		
0	27	1,10	5		
1	27	1,10	5		

1256PE

inserti 4 mm
per viti con impronta esagonale



mm	L mm	€	🔧	📦	012560021
0.7	27	1,10	5		
0.9	27	1,10	5		
1.3	27	1,10	5		
1.5	27	1,10	5		
2.0	27	1,10	5		

1256TX

inserti 4 mm
per viti con impronta Torx®



T	L mm	€	🔧	📦	012560041
T3	27	1,15	5		
T4	27	1,15	5		
T5	27	1,15	5		
T6	27	1,15	5		
T7	27	1,15	5		
T8	27	1,15	5		
T9	27	1,15	5		
T10	27	1,15	5		
T15	27	1,15	5		

1256RTX

inserti 4 mm
per viti con impronta Tamper Resistant Torx®



T	L mm	€	🔧	📦	012560051
T6	27	1,37	5		
T7	27	1,37	5		
T8	27	1,37	5		
T9	27	1,37	5		
T10	27	1,37	5		

1256/20

prolunga con attacchi esagonali
maschio e femmina da 4 mm

1256/20	€	🔧	📦	012560092
	6,90	5		

1256/30

portainseri da 4 mm con impugnatura

L mm	€	🔧	📦	012560097
110	8,20	2		

1257LP

microgiravite per viti senza testa
con intaglio



SxD mm	L mm	€	🔧	📦	012570012
0,25x1,2	60	4,40	5		
0,23x1,5	60	4,40	5		
0,3x1,8	60	4,40	5		
0,4x2	60	4,40	5		
0,4x2,5	60	4,40	5		
0,5x3	60	4,40	5		
0,6x3,5	60	4,40	5		
0,8x4	60	4,40	5		



1257LP/S8 € 55,00 1 012570200
 0,2x1,2-0,25x1,5
 0,3x1,8-0,4x2-0,4x2,5
 0,5x3-0,6x3,5-0,8x4 mm

1257PH

microgiravite per viti con impronta a croce Phillips®



PH	L mm	€	Icon	Code
00	60	4,40	5	012570060
0	60	4,40	5	012570063
1	60	4,40	5	012570066

1257LPH/S8



1257LPH/S8 € 55,00 1 012570210
 1257PH PH00-PH0-PH1
 1257LP 0,4x2-0,4x2,5-0,5x3
 0,6x3,5-0,8x4 mm

1257ES

microgiravite a chiave maschio esagonale



mm	L mm	€	Icon	Code
0,9	60	4,85	5	012570045
1,3	60	4,85	5	012570046
1,5	60	4,85	5	012570047
2	60	4,85	5	012570048
2,5	60	4,85	5	012570049
3	60	4,85	5	012570050

1257ESB/S8



1257ESB/S8 € 62,00 1 012570230
 1257ES 0,9-1,3-1,5-2-2,5-3 mm
 1257BE 4-5 mm

1257TX

microgiravite a chiave maschio per viti con impronta Torx®



Icon	L mm	€	Icon	Code
T5	60	5,20	5	012570075
T6	60	5,20	5	012570076
T7	60	5,20	5	012570077
T8	60	5,20	5	012570078
T9	60	5,20	5	012570079
T10	60	5,20	5	012570080
T15	60	5,20	5	012570081
T20	60	5,20	5	012570082



1257TX/S8 € 61,50 1 012570220
 T5-T6-T7-T8
 T9-T10-T15-T20

1257BE

microgiravite chiave bussola esagonale



mm	L mm	€	Icon	Code
3,2	60	6,50	5	012570085
4	60	6,50	5	012570086
5	60	6,50	5	012570087
5,5	60	6,50	5	012570088

1260

giravite per viti a testa con intaglio



ISO 2380

SxAxL mm	L1 mm	Ø mm	€	Icon	Code
0,4x2,5x50	150	2,5	4,55	5	012600003
0,4x2,5x75	175	2,5	4,65	5	012600006
0,5x3x75	175	3,0	4,75	5	012600009
0,5x3x100	200	3,0	4,90	5	012600012
0,6x3,5x75	175	3,5	5,10	5	012600018
0,6x3,5x100	200	3,5	5,20	5	012600021
0,8x4x100	208	4,0	5,70	5	012600030
0,8x4x125	233	4,0	5,90	5	012600033
0,8x4x150	258	4,0	6,10	5	012600036
1x5,5x100	208	5,0	6,50	5	012600039
1x5,5x125	233	5,0	6,60	5	012600040
1x5,5x150	258	5,0	7,20	5	012600042
1,2x6,5x100	219	6,0	7,80	5	012600048
1,2x6,5x125	244	6,0	8,05	5	012600050
1,2x6,5x150	269	6,0	8,40	5	012600051
1,2x8x150	277	8,0	10,30	3	012600057
1,2x8x200	327	8,0	10,70	3	012600060
1,6x10x200	327	9,5	12,90	3	012600066
2x12x250	377	10	15,20	3	012600069
2x14x250	377	10	16,20	2	012600073



1260/S6 € 41,50 1 012600306
 0,4x2,5x75-0,5x3x75-0,8x4x125
 1x5,5x150-1,2x6,5x150-1,2x8x200 mm

1260N

giravite per viti a testa con intaglio tipo cortissimo



ISO 2380

SxAxL mm	L1 mm	Ø mm	€	Icon	Code
0,8x4x30	87	4	6,00	5	012600103
1,2x6,5x30	87	6	6,60	5	012600106



1260E

giravite con esagono di manovra per viti a testa con intaglio



ISO 2380

SxAxL mm	L1 mm	Ø mm	€		
1,2x6,5x150	269	6,0	10,90	3	012600156
1,2x8x175	301	8,0	13,40	3	012600157
1,6x10x200	327	9,5	15,50	2	012600159
2x12x250	377	9,5	18,00	2	012600162

1262

giravite per viti con impronta a croce Phillips®



UNI/ISO 8764

PHxDxL mm	L1 mm	€		
0x3x60	160	4,75	5	012620003
0x3x100	200	5,05	5	012620006
1x4,5x80	188	6,25	5	012620009
1x4,5x120	228	6,80	5	012620012
2x6x100	219	7,70	5	012620018
2x6x150	269	8,50	5	012620021
3x8x150	277	11,40	3	012620024
4x10x200	327	14,50	3	012620027



1262/S4	€		
PH0x3x60-PH1x4,5x80 PH2x6x100-PH3x8x150 mm	30,00	1	012620304

1262N

giravite per viti con impronta a croce Phillips® tipo cortissimo



UNI/ISO 8764

PHxDxL mm	L1 mm	€		
1x4,5x30	87	6,00	5	012620103
2x6x30	87	6,60	5	012620106

1262E

giravite con esagono di manovra per viti con impronta a croce Phillips®



UNI/ISO 8764

PHxDxL mm	L1 mm	€		
2x6x150	269	10,90	3	012620153
3x8x175	302	13,20	3	012620156
4x10x200	327	16,70	2	012620159

1262L

giravite per viti con impronta a croce Phillips®, tipo lungo



UNI/ISO 8764-1

PHxDxL mm	L1 mm	€		
0x3x300	400	8,30	3	012620203
1x4,5x300	400	9,80	3	012620205
1x4,5x400	508	11,50	3	012620206
2x6x400	519	14,80	3	012620209

1263/D...

serie giravite



1263/D6	€		
1260 0,5x3x75-0,8x4x100 1x5,5x125-1,2x6,5x150 mm	39,50	1	012630006
1262 PH1x4,5x80-PH2x6x100 mm			

1263/D7	€		
1262 PH0x3x60 PH1x4,5x80 PH2x6x100 mm	40,50	1	012630017
1264 0,5x2,5x60-0,6x3x100 0,8x4x125-1x5x125 mm			

1263/D7PZ	€		
1260 0,5x3x75-0,8x4x100 1x5,5x150-1,2x6,5x150 mm	47,00	1	012630007
1269PZ PZ0 - PZ1 - PZ2			

1263/D8	€		
1260 0,4x2,5x50-0,5x3x75 0,8x4x100-1x5,5x125 1,2x6,5x150 mm	48,50	1	012630008
1262 PH0x3x60-PH1x4,5x80 PH2x6x100 mm			

1263/D10	€		
1260 0,5x3x75-0,6x3,5x100 0,8x4x125-1x5,5x150 1,2x6,5x150 mm	62,00	1	012630010
1260N 0,8x4x30			
1262 PH0x3x60-PH1x4,5x80 PH2x6x100 mm			
1262N PH1x4,5x30			

1263/S12

serie di 12 giravite



1263/S12	€		
1260 0,4x2,5x50-0,5x3x75 0,6x3,5x100-0,8x4x125 1x5,5x125-1,2x6,5x150 1,2x8x200-1,6x10x200 mm	89,00	1	012630112
1262 PH0x3x60-PH1x4,5x80 PH2x6x100-PH3x8x150 mm			

1264

giravite per viti senza testa con intaglio



SxDxL mm	L1 mm	€		
0,5x2,5x60	160	4,55	5	012640003
0,6x3x75	175	4,75	5	012640006
0,6x3x100	200	4,90	5	012640009
0,8x4x100	208	5,70	5	012640012
0,8x4x125	233	5,90	5	012640015
1x5x125	233	6,60	5	012640018
1x5x150	258	7,00	5	012640021
1,2x6,5x150	269	8,40	5	012640024



1264/S5	€		
0,5x2,5x60-0,6x3x75 0,8x4x100-1x5x125-1,2x6,5x150 mm	30,00	1	012640305

1264L

giravite per viti senza testa con intaglio tipo lungo



SxDxL mm	L1 mm	€	U	W
0,5x2,5x200	300	6,70	3	012640203
0,6x3x300	400	7,90	3	012640206
0,8x4x400	508	10,30	3	012640209
1x5x400	508	11,50	3	012640215
1,2x6,5x400	519	14,00	3	012640218

1265ES

chiavi maschio esagonale con impugnatura



mm	L mm	L1 mm	€	U	W
1,5	100	200	5,50	3	012650015
2	100	200	5,65	3	012650020
2,5	100	200	5,85	3	012650025
3	100	200	6,10	3	012650030
4	100	208	6,75	3	012650040
5	100	219	7,80	3	012650050
6	125	244	8,80	3	012650060
8	150	277	11,70	2	012650080



1265ES/S8
1,5-2-2,5-3-4-5-6-8 mm € 58,00 1 012650308

1266BP

chiavi maschio esagonale ad estremità sferica con impugnatura



mm	L mm	L1 mm	€	U	W
2	100	200	6,00	3	012660020
2,5	100	200	6,20	3	012660025
3	125	225	6,50	3	012660030
4	125	233	7,20	3	012660040
5	120	239	8,40	3	012660050
6	140	259	9,60	3	012660060
8	160	287	12,20	2	012660080
10	160	287	14,70	2	012660100



1266BP/S8
2-2,5-3-4-5-6-8-10 mm € 71,00 1 012660308

1267TX

chiavi maschio con impugnatura per viti con impronta Torx®



Ø mm	L mm	L1 mm	Ø mm	€	U	W
T5	50	150	3	6,70	5	012670005
T6	50	150	3	7,00	5	012670006
T7	50	150	3	7,20	5	012670007
T8	60	160	3	7,50	5	012670008
T9	60	167	4	7,90	5	012670009
T10	80	188	4	8,20	5	012670010
T15	80	188	4	8,70	5	012670015
T20	100	208	4,5	9,10	5	012670020
T25	100	208	5	9,80	5	012670025
T27	115	234	6	10,30	5	012670027
T30	115	234	6	10,80	5	012670030
T40	130	257	7	12,50	2	012670040
T45	130	257	8	13,80	2	012670045



1267TX/D7
T6-T8-T10-T15
T20-T25-T30 € 61,00 1 012670307



1267TX/S13
T5-T6-T7-T8-T9
T10-T15-T20-T25
T27-T30-T40-T45 € 119,50 1 012670312

1268RTX

chiavi maschio con impugnatura per viti con impronta Tamper Resistant Torx®



Ø mm	L mm	L1 mm	Ø mm	€	U	W
T9	60	167	4,0	8,55	3	012680009
T10	80	188	4,0	8,85	3	012680010
T15	80	188	4,0	9,15	3	012680015
T20	100	208	4,5	9,80	3	012680020
T25	100	208	5,0	10,10	3	012680025
T27	115	234	6,0	10,80	3	012680027
T30	115	234	6,0	11,00	3	012680030
T40	130	257	7,0	12,70	2	012680040



1268RTX/S8
T9-T10-T15-T20
T25-T27-T30-T40 € 81,00 1 012680307

1269PZ

giravite per viti con impronta a croce Pozidriv®-Supadriv®



UNI/ISO 8764

PZ	L mm	L1 mm	€	U	W
0	60	160	5,45	5	012690000
1	80	188	7,10	5	012690001
2	100	219	8,60	5	012690002
3	150	277	12,20	3	012690003
4	200	327	15,70	3	012690004



1269PZ/S4
PZ0-PZ1-PZ2-PZ3 € 33,50 1 012690304

1269N/PZ

giravite per viti con impronta a croce Pozidriv®-Supadriv® tipo cortissimo



UNI/ISO 8764

PZ	L mm	L1 mm	€	5	012690011
1	30	87	6,00	5	012690011
2	30	87	6,60	5	012690012

1281BG

impugnatura porta lame giravite



L mm	Ø mm	€	5	012810280
118	10	10,00	5	012810280

1281PM

portainseri magnetico ad innesto rapido



L mm	€	5	012810292
165	17,20	5	012810292

1281PB

portabussole quadro maschio 1/4"



L mm	€	5	012810293
175	13,70	5	012810293

1281LP

giravite bivalenti per viti a testa con intaglio



	€	5	012810302
1281LP/1 0,8x4-1,2x6,5 mm	8,80	5	012810302
1281LP/2 1x5,5-1,2x6,5 mm	8,80	5	012810304

1281PH

giravite bivalenti per viti con impronta a croce Phillips®



PH	€	5	012810310
1-2	8,80	5	012810310
2-3	8,80	5	012810312

1281LPH

giravite bivalenti per viti a testa con intaglio e Phillips®



	€	5	012810321
1281LPH/1 PH0-0,8x4 mm	8,80	5	012810321
1281LPH/2 PH1-1x5,5 mm	8,80	5	012810322
1281LPH/3 PH2-1,2x6,5 mm	8,80	5	012810323

1281PZ

giravite bivalenti per viti con impronta a croce Pozidriv®-Supadriv®



PZ	€	5	012810330
1-2	8,80	5	012810330
2-3	8,80	5	012810332

1281PE

chiavi maschio esagonale bivalenti con un'estremità sferica



mm	€	5	012810342
2,5	8,70	5	012810342
3	8,70	5	012810343
4	8,70	5	012810344
5	8,70	5	012810345
6	8,70	5	012810346

1281TX

chiavi maschio bivalenti per viti con impronta Torx®

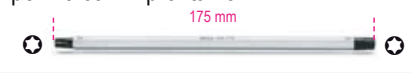

	€	5	012810349
1281TX/1 T6-T8	9,50	5	012810349
1281TX/2 T7-T9	9,50	5	012810350
1281TX/3 T10-T15	9,50	5	012810351
1281TX/4 T20-T25	9,50	5	012810352
1281TX/5 T30-T40	9,50	5	012810353

1281RTX

chiavi maschio bivalenti per viti con impronta Tamper Resistant Torx®



	€	5	012810361
1281RTX/3 T10-T15	9,70	5	012810361
1281RTX/4 T20-T25	9,70	5	012810362
1281RTX/5 T30-T40	9,70	5	012810363

1281BG/A9

assortimento di 9 giravite bivalenti e 1 impugnatura di manovra, in astuccio



	€	1	012810520
1281BG/A9	102,50	1	012810520

	1281BG
+	1281LPH/1 PH0-0,8x4 mm
+	1281LPH/2 PH1-1x5,5 mm
+	1281LPH/3 PH2-1,2x6,5 mm
+	1281PZ/1 PZ1-PZ2
○	1281PE 2,5 mm
○	1281PE 3 mm
○	1281PE 4 mm
○	1281PE 5 mm
○	1281PE 6 mm

1281BG-TX/A8

assortimento di 8 giravite bivalenti e 1 impugnatura di manovra, in astuccio



	€	1	012810530
1281BG-TX/A8	98,00	1	012810530

	1281BG
+	1281LPH/1 PH0-0,8x4 mm
+	1281LPH/2 PH1-1x5,5 mm
+	1281LPH/3 PH2-1,2x6,5 mm
+	1281TX/1 T6-T8
+	1281TX/2 T7-T9
+	1281TX/3 T10-T15
+	1281TX/4 T20-T25
+	1281TX/5 T30-T40

1281BG/B28A

assortimento di 16 giravite bivalenti, 9 chiavi a bussola 1/4", 2 accessori e 1 impugnatura di manovra, in busta

14"



1281BG/B28A € 228,50 1 012810510

○ 900	4 - 4,5 - 5 - 5,5 6 - 7 - 8 - 9 - 10 mm
1281BG	
1281PB	■ 1/4
900/25	
● 1281LP/1	0,8x4 - 1,2x6,5 mm
● 1281LP/2	1,0x5,5 - 1,2x6,5 mm
● 1281PH/1	PH1 - PH2
● 1281PH/2	PH2 - PH3
● 1281PZ/1	PZ1 - PZ2
● 1281PZ/2	PZ2 - PZ3
○ 1281PE	2,5 - 3 - 4 - 5 - 6 mm
○ 1281TX/1	T6 - T8
○ 1281TX/2	T7 - T9
○ 1281RTX/3	T10 - T15
○ 1281RTX/4	T20 - T25
○ 1281RTX/5	T30 - T40

1281BV € 15,00 1 012810501

1290

giravite per viti a testa con intaglio



ISO 2380

SxAxL mm	L1 mm	Ø mm	€	1	012900003
0,4x2,5x50	146	2,5	5,60	5	012900003
0,4x2,5x75	171	2,5	5,80	5	012900006
0,5x3x75	171	3,0	5,90	10	012900009
0,5x3x100	196	3,0	6,20	10	012900012
0,6x3,5x75	171	3,5	6,70	10	012900018
0,6x3,5x100	196	3,5	6,80	10	012900021
0,8x4x100	196	4,0	6,90	10	012900030
0,8x4x125	221	4,0	7,10	10	012900033
0,8x4x150	246	4,0	7,50	10	012900036
1x5,5x100	209	5,0	7,70	10	012900039
1x5,5x150	259	5,0	8,60	10	012900042
1,2x6,5x100	220	6,0	9,50	10	012900048
1,2x6,5x150	270	6,0	10,10	10	012900051
1,2x8x150	282	7,0	12,70	3	012900057
1,2x8x200	332	7,0	13,50	3	012900060
1,6x10x200	332	8,0	15,80	3	012900066
2x12x250	382	10	21,30	2	012900069

Beta INOX

STAINLESS STEEL

275

1290/S

serie giravite



1290/S5 € 44,00 1 012900305

1290 0,5x3x75-0,8x4x100 -1x5,5x150
1,2x6,5x150 -1,2x8x150 mm

1290/S9X € 83,00 1 012900319

1290 0,4x2,5x75 - 0,5x3,5x100
0,8x4x125 - 1x5,5x150
1,2x6,5x150 - 1,2x8x200
1,6x10x200 mm
1290N 0,8x4x30 -1,2x6,5x30 mm

1290N

giravite per viti a testa con intaglio
tipo cortissimo



ISO 2380

SxAxL mm	L1 mm	Ø mm	€	5	012900103
0,8x4x30	86	4	7,30	5	012900103
1,2x6,5x30	86	6	8,10	5	012900106

1292

giravite per viti
con impronta a croce Phillips®



UNI/ISO 8764

PHxDxL mm	L1 mm	€	10	012920003
0x3x60	156	5,40	10	012920003
0x3x100	196	6,10	5	012920006
1x4,5x80	189	7,40	10	012920009
1x4,5x120	229	8,20	10	012920012
2x6x100	220	9,60	10	012920018
2x6x150	270	10,50	10	012920021
3x8x150	282	13,30	3	012920024
4x10x200	332	18,40	3	012920027

+



1292/S4 € 35,50 1 012920304
PH0x3x60-PH1x4,5x80
PH2x6x100-PH3x8x150 mm

1292N

giravite per viti con impronta
a croce Phillips®
tipo cortissimo

+



UNI/ISO 8764

PHxDxL mm	L1 mm	€	5	012920103
1x4,5x30	86	7,00	5	012920103
2x6x30	86	7,60	5	012920106

1292L

giravite per viti con impronta
a croce Phillips®, tipo lungo

+



UNI/ISO 8764-1

PHxDxL mm	L1 mm	€	3	012920203
0x3x300	396	11,90	3	012920203
1x4,5x400	509	14,70	3	012920206
2x6x400	520	18,00	3	012920209

Beta INOX

STAINLESS STEEL

275

1293/D...

serie giravite

Betamax
MAXIMUM PERFORMANCE



1293/D6 € 48,00 1 012930401

1290 0,6x3,5x75-1x5,5x150
1,2x6,5x150 mm
1292 PH0x3x60 -PH1x4,5x80
PH2x6x100 mm

1293/D8 € 66,50 1 012930403

1290 0,5x3x75-0,8x4x100
1x5,5x150-1,2x6,5x150
1,2x8x150 mm
1292 PH0x3x60 -PH1x4,5x80
PH2x6x100 mm

1293/S...

serie giravite

Betamax
MAXIMUM PERFORMANCE



1293/S8 € 59,50 1 012930208

1290 2,5x50-3x75-4x100-5,5x150
6,5x150 mm
1292 PH0x3x60 -PH1x4,5x80
PH2x6x100 mm

1293/S10 € 94,50 1 012930201

1290 0,4x2,5x50 -0,6x3,5x100
1x5,5x100-1,2x6,5x150
1,2x8x150-1,6x10x200 mm
1292 PH0x3x60 -PH1x4,5x80
PH2x6x100-PH3x8x150 mm

1293/S12 € 103,00 1 012930203

1290 0,5x3x75-0,8x4x125
1x5,5x150-1,2x6,5x150
1,2x8x200 mm
1290N 0,8x4x30 mm
1292 PH0x3x60 -PH1x4,5x80
PH2x6x100-PH3x8x150 mm
1292N PH1x4,5x30-PH2x6x30 mm

1293/S7 € 48,50 1 012930207

1292 PH0x3x60 -PH1x4,5x80
PH2x6x100 mm
1294 0,5x2,5x60-0,6x3x75
0,8x4x100-1x5x125 mm

1293ES

chiavi maschio esagonale
con impugnatura



mm	L mm	L1 mm	Ø mm	€		
2	100	196	3	7,50	5	012930001
2,5	100	196	4	7,50	5	012930002
3	100	196	4	7,80	5	012930003
4	100	196	5	8,80	5	012930004
5	100	209	6	9,60	5	012930005
6	125	245	7	11,00	5	012930006
8	150	282	10	14,70	2	012930008



1293ES/S7 € 67,00 1 012930057
2-2,5-3-4-5-6-8 mm

1293BP

chiavi maschio esagonale
ad estremità sferica con impugnatura



mm	L mm	L1 mm	€		
2	100	196	7,60	5	012930501
2,5	100	196	7,60	5	012930502
3	100	196	7,90	5	012930503
4	100	196	8,80	5	012930506
5	100	209	9,60	5	012930509
6	125	245	11,30	5	012930512
8	150	282	15,30	2	012930515



1293BP/S7 € 68,00 1 012930558
2-2,5-3-4-5-6-8 mm

1294

giravite per viti senza testa
con intaglio



SxDxL mm	L1 mm	€		
0,5x2,5x60	156	5,25	5	012940003
0,6x3x75	171	5,50	5	012940006
0,6x3x100	196	5,70	5	012940009
0,8x4x100	196	6,90	5	012940012
0,8x4x150	246	8,95	5	012940015
1x5x125	234	8,70	5	012940018
1,2x6,5x150	282	10,20	5	012940027



1294/S5 € 36,50 1 012940305
0,5x2,5x60-0,6x3x100
0,8x4x100-1x5x125
1,2x6,5x150 mm

1294L

giravite per viti senza testa con intaglio
tipo lungo



SxDxL mm	L1 mm	€		
0,6x3x300	396	11,40	3	012940206
0,8x4x400	496	13,50	3	012940209
1x5x400	509	16,60	3	012940215
1,2x6,5x400	532	18,50	3	012940218

1295

giravite a percussione



L mm 130 € 50,00 1 012950001

Beta
Quality Tools

1295/C14

giravite a percussione
con 14 inserti e bussola portainseriti



1295/C14 € 120,50 1 012950108

	866LP	1,2x6,5 - 1,6x10 mm
	866PH	PH2 - PH3
	866PZ	PZ2 - PZ3
	866PE	5 - 6 mm
	866TX	T27 - T30 - T40 - T45 - T50 - T55
	895/6	□ 1/2 - ○ 5/16
	1295	■ 1/2

170x100x35 mm - 1,3 kg

1297TX

chiavi maschio con impugnatura
per viti con impronta Torx®



	L mm	L1 mm	Ø mm	€		
T6	50	146	3,0	9,80	5	012970006
T7	50	146	3,0	10,00	5	012970007
T8	60	156	3,0	10,10	5	012970008
T9	60	169	4,0	10,60	5	012970009
T10	80	189	4,0	11,20	5	012970010
T15	80	189	4,0	11,30	5	012970015
T20	100	209	4,5	11,60	5	012970020
T25	100	209	5,0	12,00	5	012970025
T27	115	235	6,0	12,30	5	012970027
T30	115	235	6,0	13,00	5	012970030
T40	130	262	7,0	14,50	2	012970040
T45	130	262	8,0	16,50	2	012970045



1297TX/S12 € 143,00 1 012970312
T6-T7-T8-T9-T10
T15-T20-T25-T27
T30-T40-T45



1297TX/D6 € 71,50 1 012970409
T10-T15-T20
T25-T27-T30

1297TX/L

chiavi maschio con impugnatura
per viti con impronta Torx®, tipo lungo



	L mm	L1 mm	Ø mm	€		
T15	210	319	4,0	12,50	2	012970115
T20	210	319	4,5	12,90	2	012970120
T25	210	319	5,0	13,30	2	012970125
T30	210	330	6,0	14,30	2	012970130
T45	210	342	8,0	15,50	2	012970145



1297TX/L-S5 € 68,50 1 012970325
TX/L15-TX/L20-TX/L25-
TX/L30-TX/L45

1298RTX

chiavi maschio con impugnatura
per viti con impronta
Tamper Resistant Torx®



	L mm	L1 mm	Ø mm	€		
T9	60	169	4,0	11,60	5	012980009
T10	80	189	4,0	11,80	5	012980010
T15	80	189	4,0	12,50	5	012980015
T20	100	209	4,0	12,60	5	012980020
T25	100	209	4,5	12,90	5	012980025
T27	115	235	5,5	14,00	5	012980027
T30	115	235	6,0	14,50	5	012980030
T40	130	262	7,0	15,50	2	012980040



1298RTX/S8 € 105,50 1 012980308
T9-T10-T15-T20
T25-T27-T30-T40

1299PZ

giravite per viti con impronta
a croce Pozidriv®-Supadriv®



UNI/ISO 8764

PZ	L mm	L1 mm	€		
0	60	156	7,70	5	012990000
1	80	189	9,00	5	012990003
2	100	220	12,30	5	012990006
3	150	282	17,80	2	012990009
4	200	332	25,00	2	012990012



1299PZ/S6 € 65,00 1 012990306
1299PZ PZ0-PZ1-PZ2-PZ3
1299N/PZ PZ1-PZ2

1299N/PZ

giravite per viti con impronta
a croce Pozidriv®-Supadriv®
tipo cortissimo



UNI/ISO 8764

PZ	L mm	L1 mm	€		
1	30	86	8,80	5	012990021
2	30	86	9,60	5	012990024

1302

tasso con impugnatura testa tonda
convessa e a penna



1302 g 770 € 78,00 1 013020001

1303
tasso a virgola



g 1350 € 59,50 1 013030001

1304
tasso a suola



g 875 € 74,50 1 013040001

1305
tasso curvo



g 1190 € 47,00 1 013050001

1305Z
tasso curvo zigrinato



g 1065 € 56,00 1 013050002

1306
tasso a tacco bombato



g 1040 € 44,50 1 013060001

1307
tasso rettangolare bombato



g 1100 € 87,00 1 013070001

1308
tasso ovoidale



g 1100 € 81,00 1 013080001

1309
tasso a doppia penna



g 460 € 52,00 1 013090001

1310
tasso a rotaia



g 1225 € 49,50 1 013100001

1312
tasso a incudine



g 1220 € 107,00 1 013120001

1313
tasso a tampone



g 990 € 72,50 1 013130001

1314
tasso a teste tonde
convessa e piana



g 760 € 47,50 1 013140001

1326
leva a cazzuola



g 560 € 42,50 1 013260001

1327
leva a cucchiaio
pesante



g 1075 € 60,00 1 013270001

1328
leva a cucchiaio
leggera



g 935 € 54,00 1 013280001

1329

leva curva e piana



435 mm

1800 g € 164,00 1 013290001

1330

leva a gomito e piana



510 mm

2125 g € 175,00 1 013300001

1331

leva a gola con linguetta in cuoio



410 mm

1100 g € 97,00 1 013310001

1335BM

battilamiera con impugnatura in materiale plastico



375 mm

500 g € 29,00 2 013350010

1337/S5

serie di 5 spatoline per carrozzieri in acciaio inox tipo giapponese



L

25-50-75-100-125 mm € 10,90 1 013370015

1338A - 1338B

portalima con lima a dentatura radiale, piatta flessibile



L

	mm/1"	L mm	€		
1338A	9	360	81,00	2	013380001
1338B	12	360	84,50	2	013380002

1338

portalima per 1338R



1338 € 44,00 2 013380003

1338R9 - 1338R12

lime di ricambio per 1338A e 1338B



	mm/1"	€		
1338R9	9	37,00	2	013380004
1338R12	12	40,50	2	013380005

1342

scalpello extrapiatto con tagliente diritto



L mm 235 € 25,00 5 013420001

1342PM

scalpello extrapiatto con tagliente diritto con paramano



L mm 235 L1 mm 118 € 35,50 2 013420002

1342PMR

paramano di ricambio per 1342



1342PMR € 10,50 1 013420003

1343

scalpello piatto con tagliente laterale



L mm 200 € 26,50 5 013430001

1344

coppia di spessimetri per carrozzieri a 10 lame con ventosa di fissaggio

indicati per:

- posizionamento lunotti
- mantenimento della posizione durante i montaggi



1344 € 31,00 1 013440010

1345

martello con testa tonda convessa e penna manico in legno



1345 € 37,00 2 013450010

1351

martello con testa tonda piana e penna sferica manico in legno



1351 € 37,50 2 013510010

1353

martello con testa tonda piana e penna a punta manico in legno



1353 € 38,50 2 013530010

1357Z/45

martelli con teste piane
tonda zigrinata e quadra liscia
manico in legno



1357Z/45 € 61,50 2 013570045

1359T

martello con testa tonda convessa
e penna orizzontale
manico in legno



1359 T € 36,50 2 013590010

1360G

martello in gomma morbida antirimbato,
per montaggio guarnizioni e componenti
delicati

l'estrema morbidezza del battente permette di non
danneggiare
le parti lavorate, in quanto assorbe l'urto deformandosi



L mm 280 Ø mm 72 € 62,00 1 013600000

1360/K6

martello in alluminio con testa tonda piana,
puntali di plastica intercambiabili e bulino

fornito con:
• 4 puntali di plastica
• 1 bulino regolabile in 2 differenti lunghezze
applicabile al martello



L mm 320 Ø mm 34 € 71,50 1 013600006

1360/KP3

martelli con teste sferiche e penna a punta
pì punzone, in materiale plastico

Contenuto del kit:
• 1 martello da 210 g con testa Ø 30 mm
• 1 martello da 290 g con testa Ø 40 mm
• 1 punzone da 75 g con punta da 5 mm



1360/KP3 € 68,00 1 013600503

1361/C12

serie di puntali in Teflon®
per carrozzeria



1361/C12 € 107,00 1 013610012

275x160x57 mm

1362

piastra di riscontro bolli
applicabile con ventosa

permette di rilevare anche le
più piccole imperfezioni della carrozzeria



LxH mm 240 x 200 € 66,00 1 013620010

1365/K13

pompa oleodinamica 10 t e kit accessori per
carrozzeria
in trolley

Inclusi nel kit:
• pompa oleodinamica 10 tonnellate con tubo flessibile da 1,5 m attacco 1/2"
• pistone corsa 205 mm
• pinza divarica-parafanghi capacità 500 kg
• piastra di appoggio 150x90 mm
• base a "L" 50x50 mm
• punzone a 4 punti
• punzone zigrinato tondo Ø 50 mm
• punzone a cuneo 43 mm
• prolunga 240 mm
• prolunga 450 mm
• prolunga 475 mm
• testa in gomma
• raccordo maschio maschio per montaggio accessori



1365/K13 € 565,00 1 013650013

900x420x180 mm

1365P10

pompa oleodinamica

Tubo da 1,5 m attacco 1/2"
Max 690 bar



1365P10 € 252,00 1 013650110

1366A

attrezzo levabolli
con kit di 19 funghetti di plastica
da utilizzare con colla a caldo
per superfici verniciate 1851VK-12V

ideale per:
• bolli da grandine
• ammaccature causate da portiera
• piccole ammaccature in genere



1366A € 74,00 1 013660200



1366KF

kit 19 funghetti di plastica
per articolo 1366A



1366KF € 27,00 1 013660205

1366/K5

tirabolli pneumatico a massa battente
da 1,1 kg

Inclusi nel kit:
• 1 ventosa Ø 75 mm
• 1 ventosa Ø 100 mm
• 1 ventosa Ø 125 mm
• 1 gancio



1366/K5 € 194,00 1 013660010
610x240x90 mm

1366S

spotter carrellato per carrozzeria

- microprocessore per la gestione dei parametri di saldatura
- regolazione di potenza e tempo di saldatura
- campo di regolazione 400÷2200 Ah
- selettore punto singolo, pulsato, continuo
- tabella parametri di saldatura
- indicatore protezione termica
- pistola con attacco rapido
- tensione 230 V

CE



1366S € 1.340,00 1 013660000

1366S KIT

kit accessori per spotter

- 10 rondelle asolate
- 10 rondelle asolate a 90°
- 100 perni filettati 5x18 mm
- 100 perni autofilettanti 5x18 mm
- 100 perni autofilettanti 5x25 mm
- gancio per rondelle Ø 8x16x1,5 mm
- elettrodo per viti M5-M6
- elettrodo per rondelle asolate



1366S KIT € 178,00 1 013660001
250x170x35

1366SL

leva a tirare
per ripristino lamiera

testina multigancio snodata
per utilizzo con filo ondulato



L
mm
700 € 155,00 1 013660002

1366ST

traversa di tiro
per ripristino lamiera

testina multigancio snodata
per utilizzo con filo ondulato



L
mm
850 € 492,00 1 013660003

1366S/R1

mandrino per rondelle
a 3 punte



1366S/R1 € 19,30 1 013660501

1366S/R2

rondella a 3 punti
per tiraggio lamiera



1366S/R2 € 19,30 1 013660502

I prezzi indicati sono relativi a 20 pezzi

1366S/R3

elettrodo per rondelle
Ø 8x16x1,5 mm



1366S/R3 € 23,30 1 013660503

1366S/R4

gancio per rondelle Ø 8x16x1,5 mm



1366S/R4 € 20,30 1 013660504

1366S/R5

rondelle Ø 8x16x1,5 mm



1366S/R5 € 11,20 1 013660505

I prezzi indicati sono relativi a 100 pz

1366S/R6

elettrodo per viti M5-M6



1366S/R6 € 22,50 1 013660506

1366S/R7

100 perni autofilettanti 5x18 mm



1366S/R7 € 19,30 1 013660507

1366S/R8

100 perni autofilettanti 5x25 mm



1366S/R8 € 26,50 1 013660508

1366S/R9

100 perni filettati M 5x18 mm



1366S/R9 € 17,80 1 013660509

1366S/R10

10 rondelle asolate



1366S/R10 € 12,30 1 013660510

1366S/R11

elettrodo per rondelle asolate



1366S/R11 € 63,00 1 013660511

1366S/R12

10 rondelle asolate a 90°



1366S/R12 € 24,50 1 013660512

1366S/R13

elettrodo carbone calda-lamiere



1366S/R13 € 46,00 1 013660513

I prezzi indicati sono relativi a 5 pezzi

1366S/R14

elettrodo per puntatuta filo



1366S/R14 € 22,30 1 013660514

1366S/R21

filì ondulati per utilizzo leva e traversa di tiro



1366S/R21 € 15,20 1 013660551

I prezzi indicati sono relativi a 10 pz

1366S/R22

supporto magnetico per filo ondulato



1366S/R22 € 53,00 1 013660552

1366S/R24

anello di tiro M4



1366S/R24 € 61,00 1 013660554

I prezzi indicati sono relativi a 5 pezzi

1366S/R25

anello di tiro M5



1366S/R25 € 61,00 1 013660555

I prezzi indicati sono relativi a 5 pezzi

1366S/R26

anello di tiro M6



1366S/R26 € 61,00 1 013660556

I prezzi indicati sono relativi a 5 pezzi

1367/S4

serie di fustelle per installazione sensori di parcheggio

misure: 23 - 24 - 27 - 28 mm

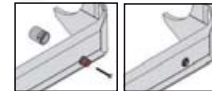

1367/S4 € 178,00 1 013670104

1367/K10

kit di fustelle per installazione sensori di parcheggio

Incluse nel kit:

• misure: 17 - 18 - 18,2 - 19 - 20 - 22,5 - 24 - 26 - 26,7 - 32 mm



Ø 12 mm

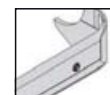

1367/K10 € 150,00 1 013670200

190x130x58 mm



1368

kit ripara plastiche

• permette di riparare velocemente crepe e rotture di parti in plastica

Alimentazione: 220+240 V con presa Shuko

Lunghezza cavo pistola termica: 3,5 m

Lunghezza cavo alimentazione: 1,35 m

2 regolazioni di potenza: 35-75 W

Pistola termica con terminali in ottone a 2 angolazioni di inserimento graffetta: 0°-90°

Protezione input: disgiuntore termico

Protezione output: fusibile 10 A

Tasca metallica per riporre la pistola

Fornito senza graffette

CE



1368 € 350,00 1 013680001

1368G/K400

assortimento di 400 graffette per 1368



1368G/K400 € 59,00 1 013680140

1368G/OD

graffette ondulate diritte per 1368



1368G/OD € 14,80 1 013680100

I prezzi indicati sono relativi a 100 pezzi

1368G/SD

graffette a spirale diritte per 1368



1368G/SD € 14,80 1 013680110

I prezzi indicati sono relativi a 100 pezzi

1368G/CV

graffette per angoli convessi per 1368



1368G/CV € 14,80 1 013680120

I prezzi indicati sono relativi a 100 pezzi

1368G/C2U

graffette per angoli concavi per 1368



1368G/C2U € 14,80 1 013680130

I prezzi indicati sono relativi a 100 pezzi

1369/C11

assortimento di 11 utensili



1369/C11 € 677,00 1 013690033



470x340x70 mm - 15,2 kg

1370

martelli tipo tedesco per meccanici manico in legno



UNI 7778 DIN 1041

HICKORY

g	A mm	L mm	L1 mm	€		
100	15	260	82	9,80	5	013700051
200	19	280	95	11,20	5	013700052
300	23	300	105	12,70	5	013700053
400	25	310	112	14,40	5	013700054
500	27	320	118	15,50	5	013700055
600	30	330	122	18,00	5	013700056
800	33	350	130	20,30	4	013700058
1000	36	360	135	23,90	4	013700060
1500	42	380	145	28,00	2	013700065
2000	47	400	155	33,00	1	013700070

1370/MR...

manici di ricambio per 1370



	€		
1370MR 100	4,50	4	013700081
1370/100			
1370MR 200	4,90	4	013700082
1370/200			
1370MR 300	5,40	4	013700083
1370/300			
1370MR 400	5,80	4	013700084
1370/400			
1370MR 500	6,30	4	013700085
1370/500			
1370MR 600	7,00	4	013700086
1370/600			
1370MR 800	7,30	4	013700088
1370/800			
1370MR 1000	7,80	4	013700090
1370/1000			
1370MR 1500	8,80	4	013700095
1370/1500			
1370MR 2000	9,80	4	013700100
1370/2000			

1370T

martelli tipo tedesco per meccanici manico in fibra



g	A mm	L mm	L1 mm	€		
200	19	280	95	17,20	5	013700620
300	23	300	105	18,80	5	013700630
500	27	320	118	20,40	5	013700650
800	33	350	130	21,90	4	013700680
1000	36	360	135	28,00	4	013700700
1500	42	365	145	32,50	2	013700750

1370F

martelli tipo francese per meccanici manico in legno



NF E 71.014

HICKORY

A mm	L mm	L1 mm	g	€		
24	260	77	280	17,30	2	013700424
26	260	80	310	18,30	2	013700426
28	280	86	400	19,30	2	013700428
30	280	92	450	20,30	2	013700430
32	300	100	550	21,40	2	013700432
36	300	104	720	28,00	2	013700436
40	330	110	1065	31,00	2	013700440
42	330	116	1080	32,50	2	013700442
50	380	138	1760	34,00	2	013700450
60	380	160	2585	42,00	2	013700460

1370F/MR...

manici di ricambio per 1370F



	€		
1370F/MR 24 1370F/24-26	4,40	2	013700474
1370F/MR 28 1370F/28-30	4,70	2	013700478
1370F/MR 32 1370F/32-36	5,50	2	013700482
1370F/MR 40 1370F/40-42	6,90	2	013700490
1370F/MR 50 1370F/50	7,80	2	013700495
1370F/MR 60 1370F/60	9,40	2	013700496

1370FT

martelli tipo francese per meccanici,
manico in fibra



A mm	L mm	L1 mm	g	€		
28	280	86	530	28,50	1	013700528
30	280	92	625	30,00	1	013700530
32	300	100	750	31,50	1	013700532
36	300	104	930	36,50	1	013700536
40	330	110	1150	38,50	1	013700540
42	330	116	1250	39,50	1	013700542
50	380	138	2100	45,00	1	013700550
60	380	160	2750	48,00	1	013700560

1374F

martelli tipo francese
per falegnami
manico in legno



A mm	L mm	L1 mm	g	€		
16	250	80	180	13,80	2	013740416
20	270	86	250	15,30	2	013740420
22	290	92	335	15,80	2	013740422
26	290	103	425	17,80	2	013740426
28	310	108	510	18,80	2	013740428
30	310	117	580	19,80	2	013740430

1374F/MR...

manici di ricambio per 1374F



	€		
1374F/MR 16 1374F/16	4,00	2	013740456
1374F/MR 20 1374F/20	4,10	2	013740460
1374F/MR 22 1374F/22-26	4,20	2	013740462
1374F/MR 28 1374F/28	4,70	2	013740468
1374F/MR 30 1374F/30	5,10	2	013740470

1375

martello con penna
a granchio
manico in legno



g	L1 mm	Ø mm	L mm	€		
300	95	25	300	15,80	3	013750000

1375/MR

manici di ricambio per 1375



	€		
1375/MR	7,20	2	013750003

1375A

martelli con penna
a granchio
manico in materiale plastico



oz	g	L mm	L1 mm	€		
16	450	330	130	23,00	3	013750016
20	570	330	130	24,20	3	013750020

1375B

martelli con penna
a granchio
manico in acciaio



oz	g	L mm	L1 mm	€		
16	450	330	130	21,00	3	013750026
20	570	330	130	21,50	3	013750030

1376X

martelli a testa quadra,
con sede portachiodo e calamita,
penna a granchio, per carpentieri
manico in legno



g	A mm	L1 mm	L mm	€		
250	20	125	450	15,00	3	013760125
300	25	130	450	16,00	3	013760130
400	27	132	450	17,50	3	013760140

1376X/MR

manico di ricambio
per 1376X



	€		
1376X/MR	8,50	2	013760161

1376XT

martelli a testa quadra,
con sede portachiodo e calamita,
penna a granchio, per carpentieri
manico in materiale plastico



g	A mm	L1 mm	L mm	€		
250	20	125	500	18,20	3	013760525
300	25	130	500	19,30	3	013760530
400	27	132	500	20,40	3	013760540

1376XT/MR

manico di ricambio
per 1376XT



	€		
1376MR/XT	9,70	2	013760585

1377

martelli con testa tonda
e penna sferica
per calderai e lattonieri
manico in legno



HICKORY

g	L mm	L1 mm	€		
340	330	95	23,00	2	013770134
450	350	102	24,00	2	013770145
570	350	110	28,00	2	013770157
680	360	116	29,50	2	013770168
900	380	120	31,00	2	013770190

1377/MR...

manici di ricambio per 1377



	€		
1377MR 340 1377/340	5,00	2	013770234
1377MR 450 1377/450	5,80	2	013770245
1377MR 570 1377/570	6,40	2	013770257
1377MR 680 1377/680	6,50	2	013770268
1377MR 900 1377/900	8,10	2	013770290

1377T

martelli con testa tonda e penna sferica per calderai e lattonierimanico in fibra



g	L mm	L1 mm	€		
340	330	95	21,30	2	013770534
450	350	102	25,50	2	013770545
570	350	110	28,50	2	013770557
680	360	116	30,50	2	013770568
900	380	120	34,50	2	013770590

1378

martelli con testa tonda e penna simmetrica per calderai e lattonieri manico in legno



g	L mm	L1 mm	Ø mm	€		
340	330	100	27	20,80	2	013780134
570	350	115	32	28,00	2	013780157

1378/MR...

manici di ricambio per 1378



	L mm	L1 mm	€		
1378MR 340 1378/340	330	100	4,70	2	013780234
1378MR 570 1378/570	350	115	6,60	2	013780257

1379F

martelli tipo francese per elettricisti manico in legno



NF E 71.011

A mm	L mm	L1 mm	€		
16	250	126	13,70	2	013790416
18	250	135	14,80	2	013790418
20	260	142	15,80	2	013790420

1379F/MR...

manici di ricambio per 1379F



	€		
1379F/MR 16 1379F/16-18	4,30	2	013790426
1379F/MR 20 1379F/20	4,70	2	013790430

1380

mazzette manico in legno



UNI 7777 DIN 6475

g	A mm	L mm	L1 mm	€		
800	38	260	90	17,50	2	013800208
1000	40	260	95	19,00	2	013800210
1250	43	260	100	20,00	2	013800212
1500	45	280	110	22,80	2	013800215
2000	50	300	120	30,00	2	013800220

1380/MR...

manici di ricambio per 1380



	€		
1380MR 800 1380/800-1000-1250	5,60	2	013800238
1380MR 1500 1380/1500	6,00	2	013800245
1380MR 2000 1380/2000	6,80	2	013800250

1380S

mazzette con collare salvamanico manico in legno collare in materiale plastico



g	A mm	L mm	L1 mm	€		
800	36	260	90	19,30	2	013800400
1000	39	260	95	21,30	2	013800405
1250	43	260	100	22,80	2	013800410
1500	45	260	110	25,50	2	013800415

1380S/MR...

manici di ricambio per 1380S



	€		
1380S/MR 800 1380S/800-1000-1250	5,80	2	013800417
1380S/MR 1500 1380S/1500	6,30	2	013800419

1380T

mazzette manico in fibra



g	A mm	L mm	L1 mm	€		
800	35	260	85	27,00	2	013800308
1000	40	260	100	27,50	2	013800310
1250	42	260	110	29,50	2	013800312
1500	45	260	120	32,00	2	013800315
2000	49	295	120	38,00	1	013800320

1381

mazze a coppia manico in legno hickory



g	A mm	L mm	L1 mm	€		
3000	55	800	142	72,00	1	013810030
4000	60	900	152	80,00	1	013810040
5000	70	900	162	91,00	1	013810050
8000*	80	900	185	157,00	1	013810080

* = manico in frassino

1381/MR...

manici di ricambio per 1381



	€		
1381MR 3-4 1381/3000-4000	35,50	2	013810730
1381MR 5 1381/5000	37,50	2	013810750
1381MR 8 1381/8000	37,50	2	013810780

1381T

mazze a coppia manico in fibra



g	A mm	L mm	L1 mm	€		
3000	55	900	142	78,00	1	013810330
4000	60	900	152	86,00	1	013810340
5000	70	900	162	97,50	1	013810350
8000	82	920	180	180,00	1	013810380

1385

mazzuole
con testa in rame
manico in legno



g	A mm	L mm	L1 mm	€		
400	26	260	75	27,00	2	013850404
600	32	270	80	39,00	2	013850406
800	34	280	90	51,00	2	013850408
1000	37	280	100	63,50	2	013850410
1500	43	280	110	93,50	2	013850415
2000	48	300	120	126,00	1	013850420

1385/MR

manici di ricambio per 1385



	€		
1385MR 400 1385 400	7,80	2	013850464
1385MR 600 1385 600	8,00	2	013850466
1385MR 800 1385 800	8,30	2	013850468
1385MR 1000 1385 1000	8,90	2	013850470
1385MR 1500 1385 1500	9,80	1	013850475
1385MR 2000 1385 2000	10,10	1	013850480

1390

mazzuole con battenti intercambiabili
in materiale plastico
manico in legno



Ø mm	L mm	L1 mm	€		
22	260	70	15,50	5	013900022
28	280	85	19,20	5	013900028
35	310	95	26,00	5	013900035
45	320	107	41,50	4	013900045
60	380	128	71,00	2	013900060

1390/MR...

manici di ricambio per 1390



	€		
1390MR 22 1390/22	3,80	2	013900222
1390MR 28 1390/28	4,40	2	013900228
1390MR 35 1390/35	5,20	2	013900235
1390MR 45 1390/45	6,30	2	013900245
1390MR 60 1390/60	7,80	2	013900260

1390R

battenti di ricambio per 1390



Ø mm	€		
22	2,45	4	013900122
28	3,75	4	013900128
35	5,00	4	013900135
45	8,50	4	013900145
60	14,70	4	013900160

1390N

mazzuole con battenti intercambiabili in nylon,
manico in legno

Battenti medio-duri: 75 Shore
Resistente all'olio e all'usura
Particolarmente indicato per lavorazioni su lamiera e metalli



UNI 7784	Ø mm	L mm	L1 mm	€		
	22	260	70	15,50	3	013900522
	28	280	85	19,20	3	013900528
	35	310	95	26,00	3	013900535
	45	320	107	41,50	2	013900545
	60	380	128	71,00	2	013900560

1390NR

battenti di ricambio in nylon per 1390N



Ø mm	€		
22	2,45	4	013900622
28	3,75	4	013900628
35	5,00	4	013900635
45	8,50	4	013900645
60	14,70	4	013900660

1391

mazzuole antirimbalo
interamente rivestite in gomma



Ø mm	L mm	L1 mm	€		
35	280	90	23,80	2	013910135
50	320	105	31,50	2	013910150
55	355	110	37,00	2	013910155
65	380	130	50,00	2	013910165

1391A

mazzuole per piastrellisti
interamente rivestite in gomma



g	Ø mm	L mm	L1 mm	€		
500	45	290	100	22,70	2	013910205
1000	60	300	120	30,00	2	013910210

1392

mazzuole antirimbalo
con battenti intercambiabili
in materiale plastico
manico in acciaio



Ø mm	L mm	L1 mm	€		
30	300	105	40,00	2	013920030
35	305	115	43,00	2	013920035
40	310	125	49,00	2	013920040
50	325	135	58,50	2	013920050
60	385	155	89,50	2	013920060

1392R

battenti di ricambio per 1392



Ø mm	€		
30	5,40	4	013920230
35	7,90	4	013920235
40	12,00	4	013920240
50	15,90	4	013920250
60	23,60	4	013920260

1393

mazzuole con testa
in gomma dura



Ø mm	L mm	L1 mm	€		
50	315	90	10,60	3	013930050
60	340	110	12,00	3	013930060
70	370	130	14,30	2	013930070

1410/M

attrezzo ad uncino
per trazionamento molle



Ø mm	€	Imp.	Art.
3,5	15,00	2	014100051

1428

estrattori per dadi destrorsi danneggiati
con attacco quadro



Ø mm	□ mm	L mm	Ø mm	€	Imp.	Art.
8	3/8	36	17	15,00	2	014280008
10	3/8	36	17	15,00	2	014280010
11	3/8	36	17	15,00	2	014280011
12	3/8	36	19	15,00	2	014280012
13	3/8	36	19	15,00	2	014280013
14	3/8	36	19	15,00	2	014280014
15	1/2	38	21	16,00	2	014280015
16	1/2	38	21	16,00	2	014280016
17	1/2	38	21	16,00	2	014280017
18	1/2	38	26	16,00	2	014280018
19	1/2	38	26	16,00	2	014280019
20	1/2	38	26	17,70	2	014280020
21	1/2	38	26	17,70	2	014280021
22	1/2	38	26	19,30	2	014280022
24	1/2	38	26	19,30	2	014280024
27	1/2	38	26	20,20	2	014280027

1428L

estrattori a bussola lunghi
per dadi destrorsi danneggiati
con attacco quadro



Ø mm	€	Imp.	Art.
17	38,50	1	014280217
19	39,50	1	014280219
21	42,50	1	014280221



Art.	€	Imp.	Art.
1428L/B3	120,50	1	014280303



Art.	€	Imp.	Art.
1428/SB11	182,00	1	014280111
1428/SB5	101,00	1	014280115

1429

estrattori per viti e prigionieri danneggiati
con attacco quadro



mm	□	L mm	€	Imp.	Art.
2	3/8	60	9,90	3	014290002
3	3/8	60	9,90	3	014290003
4	3/8	60	9,90	3	014290004
5	3/8	60	10,60	2	014290005
6	3/8	60	10,60	2	014290006
8	1/2	70	11,50	2	014290008
10	1/2	70	11,70	2	014290010



Art.	€	Imp.	Art.
1429/SB7	82,50	1	014290107

1430/...

estrattori conici per viti
e prigionieri spezzati
in acciaio legato

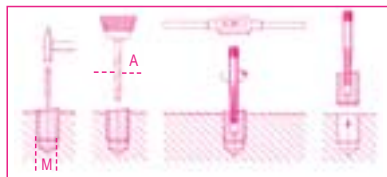

Art.	M	A mm	€	Imp.	Art.
1430/1	3÷6	2,5	2,85	10	014300006
1430/2	6÷8	3,0	3,15	10	014300008
1430/3	8÷11	4,5	3,75	10	014300011
1430/4	11÷14	6,0	4,90	10	014300014
1430/5	14÷18	8,0	5,60	10	014300018
1430/6	18÷24	11,0	10,90	5	014300024
1430/7	24÷33	14,0	16,40	5	014300033
1430/8	33÷50	21,0	20,80	5	014300050



Art.	€	Imp.	Art.
1430/S5	21,00	1	014300105
1430/S6	31,00	1	014300106
1430/S8	67,50	1	014300108

1431/...

estrattori conici per viti e prigionieri spezzati

per la rimozione di viti e prigionieri che non offrono
possibilità di presa
inserimento a percussione

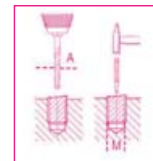

Art.	M	A	L mm	€	Imp.	Art.
1431/3	3÷6	2,5	59	5,00	10	014310051
1431/5	6÷8	5,0	68	5,00	10	014310052
1431/6	8÷11	6,0	72	6,00	10	014310053
1431/8	11÷14	8,0	77	6,50	10	014310054
1431/9	14÷18	9,0	82	7,00	10	014310055

1431/C5

estrattori conici per viti e prigionieri spezzati

Inserimento a percussione



Art.	M mm	A mm	€	Imp.	Art.
1431/C5	6÷18	3÷9	30,00	1	014310005

1433

estrattori a rulli
per viti prigioniere

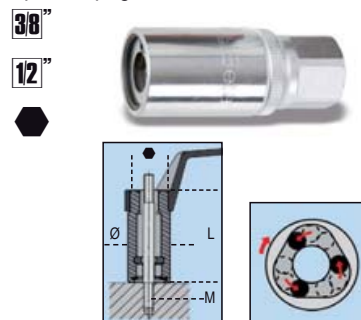

M mm	Ø mm	L mm	□ mm	€	Imp.	Art.
5	21	60	19	11,20	2	014330005
6	24	60	21	11,20	2	014330006
7	24	60	21	11,20	2	014330007
8	24	60	21	11,20	2	014330008
9	28	70	21	13,20	2	014330009
10	28	70	21	13,20	2	014330010
10,5	28	70	21	13,20	2	014330021
11	28	70	21	13,20	2	014330011
12	28	70	21	13,20	2	014330012
14	36	72	24	20,80	2	014330014
16	36	72	24	20,80	2	014330016





1433/C11

estrattori a rulli per viti prigioniere



1433/C11 € 215,00 1 014330311
 M5 - M6 - M7 - M8 - M9 - M10 - M10,5
 M11 - M12 - M14 - M16
 340x135x56 mm - 3,0 kg

1435

estrattore ad eccentrico per viti prigioniere



Ø mm 4÷20 € 81,50 1 014350001

1435R

rotella di ricambio per 1435



1435R € 25,00 1 014350010

1435/1

estrattore ad eccentrico per viti prigioniere



Ø mm 19÷26 € 101,00 1 014350002

1435/1R

rotella di ricambio per 1435/1



1435/1R € 26,00 1 014350011

1437/C12

assortimento 12 utensili per rimozione air bag



1437/C12 € 81,00 1 014370001
 260x160x55 mm - 1,0 kg

1438

attrezzo universale per centraggio frizioni completo di 3 coni ad espansione



1438 € 44,00 1 014380001

1438R

coni ad espansione di ricambio per 1438



Ø mm € 5 014380101
 14÷18 3,00 5 014380102
 18÷21 3,00 5 014380103
 22÷25 3,00 5 014380103

1438DCT

attrezzo per smontaggio, montaggio frizione cambio DCT a 6 rapporti utilizzabile su Volvo, Ford, Chrysler, Dodge

38"



1438DCT € 125,00 1 014380300

1438EVO

kit universale per centraggio frizioni

Componentistica interamente in metallo



1438EVO € 195,00 1 014380011
 290x200x60 mm - 2 kg

1438DSG

leva per bloccaggio/sbloccaggio cambio DSG a doppia frizione del gruppo VAG



1438DSG € 26,50 1 014380200

1438SAC

Kit centraggio frizioni SAC

- incluso kit per applicazioni senza cuscinetti di guida
- fornito con piastre a 3 e 4 bracci



1438 SAC € 965,00 1 014380050
 480x380x130 mm - 9,5 kg

1439/K7

cassetta giravite angolare 90° tipo lungo con lame



Dotazione valigetta:

- Giravite angolare
- 1 Testa per viti ad intaglio
- 1 Testa per bits 1/4
- 1 Testa per lame speciali
- 7 lame speciali

1439K7 € 162,00 1 014390101

500x120x60 mm 825 g

1440/...

attrezzi per inserimento pistoni



	Ø mm	L mm	€		
1440/0	40÷75	50	24,00	1	014400000
1440/1	57÷125	80	32,00	1	014400010
1440/1A	57÷125	100	36,00	1	014400011
1440/2	90÷175	80	38,50	1	014400020
1440/2A	90÷175	100	40,00	1	014400021
1440/3	90÷175	165	59,00	1	014400030

1445/1 - 1445/2

attrezzi per segmenti di pistoni



	Ø mm	€		
1445/1	50÷100	33,50	1	014450001
1445/2	90÷150	42,50	1	014450002

1450GC

morsetto alzavalvole con ganasce diritte e curve



1450GC € 95,50 1 014500005

1452K

morsetto alzavalvole con tre flange



1452K € 126,00 1 014520100

1452PN/K

attrezzo pneumatico per molle valvole motore

pressione di spinta 1400 N



Ø mm	L mm	L1 mm	€		
16-19-23	230	185	269,00	1	014520110
25-30-42					

1455SVP

smerigliavalvole pneumatico

• Pressione di utilizzo 6 Bar

CE



1455SVP € 307,00 1 014550001

1455SVP/R...

ventose in gomma di ricambio per 1455SVP



	€		
1455SVP/R1	5,50	5	014550501
1455SVP/R2	5,50	5	014550502
1455SVP/R3	5,50	5	014550503

1456/C8

kit per allineamento guarnizione della testa

consente un rapido e preciso posizionamento della guarnizione della testa

Inclusi nel kit:

- 1 coppia di perni guida M10x1,5 lunghezza 60 mm
- 1 coppia di perni guida M10x1,5 lunghezza 35 mm
- 1 coppia di perni guida M9x1,25 lunghezza 55 mm
- 1 impugnatura per rimozione perni guida
- 1 prolunga per rimozione perni guida



8 mm

1456/C8 € 62,50 1 014560010

300x90x65 mm - 650 g

1457/B4

serie di attrezzi per lo sbloccaggio dei connettori Rilsan

Misure incluse:

- 6x8
- 10x12
- 15x16
- 18x1/2



1457/B4 € 41,00 1 014570024

Beta

Beta
Quality Tools

1458

pinza per anelli elastici di sicurezza SP per alberi



DIN 5417

200 mm

Ø mm
30÷100

€
60,50



2

014580001

1460F

pinza per anelli di tenuta valvole



270 mm

1460F

€
51,50



1

014600010

1461/C3B

attrezzi per la messa in fase motori Fiat/Alfa/Lancia benzina

Motori: 1.2-1.4 16V



1461/C3B

€
281,00



1

014610032

280x245x75 mm 1,5 kg

1461/C5G

attrezzi per la messa in fase motori Fiat/Alfa/Lancia/Opel/Suzuki/Ford Diesel

Motori: 1.3 Multijet



1461/C5G

€
249,00



1

014610053

280x245x75 mm 2,6 kg

1461/C6B

attrezzi per la messa in fase motori Peugeot/Citroën benzina

Motori: 1.0-1.1-1.4-1.6-1.6 16v-1.6Gti-1.6 18V-1.8-1.8 16v-1.9-2.0-2.0 16v-2.0T-2.0 Hpi-2.2 16v



1461/C6B

€
376,00



1

014610063

310x290x120 mm 3,5 kg

1461/C6G

attrezzi per la messa in fase motori Peugeot/Citroën Diesel

Motori: 1.4-1.6-2.0D, 1.4-1.6TDCI, 1.4-1.6-2.0-2.2Hdi, 1.5-1.9-2.5D



1461/C6G

€
496,00



1

014610064

385x290x100 mm 3,8 kg

1461/C7B

attrezzi per la messa in fase motori Renault/Nissan benzina

Motori: 1.4-1.6-1.8-2.0 16V



1461/C7B

€
284,00



1

014610072

280x245x75 mm 3,2 kg

1461/C8B

attrezzi per la messa in fase motori Ford benzina

Motori: 1.25-1.4-1.6-1.6 SCTi-1.6 Ti-VCT-1.6 16V



1461/C8B

€
197,00



1

014610083

240x210x50 mm 1,8 kg

1461/C8G

attrezzi per la messa in fase motori Ford/Mazda Diesel

Motori: 1.4-1.6-1.8-2.0-2.2 TDCi, 1.6D 8/16V, 1.8D, 1.8D Turbo, 1.8 TCi, 1.8 TDDi, 2.5D, 2.5D Turbo



1461/C8G

€
340,00



1

014610084

280x245x75 mm 2,2 kg

1461/C9B

attrezzi messa in fase motori Opel benzina

Motori: 1.0 12V, 1.0-1.2-1.4 16V



1461/C9B

€
157,00



1

014610092

335x145x60 mm 2 kg

1461/C10G

attrezzi per la messa in fase motori
Volkswagen/Audi/Seat e Skoda Diesel

Motori: 1.2-1.6-2.0 TDI CR (common rail)



1461/C10G € 492,00 1 014610103

310x290x120 mm 2,8 kg

1461/C11A

attrezzi per messa in fase
motori Renault Diesel

Motori: 2.0 dCi



1461/C11A € 163,00 1 014610111

420x280x60 mm - 1,2 kg

1461/C11G

attrezzi per la messa in fase motori
Renault Diesel

Motori: 1.5-1.9-2.2-2.5 dCi



1461/C11G € 408,00 1 014610113

310x290x120 mm 3,8 kg

Beta

1461/C12A

attrezzi messa in fase
motori Fiat benzina e Diesel

Motori: 1.9-2.2 JTS e 1,9 JTD Euro 4



1461/C12A € 297,00 1 014610123

280x245x75 mm - 1,8 kg

1461/C12G

attrezzi per la messa in fase motori
Fiat/Alfa/Lancia Diesel

Motori: 1.9 JTD, 1.6-1.9-2.0 Multijet



1461/C12G € 254,00 1 014610124

280x245x75 mm 2 kg

1461/C13A

attrezzi per messa in fase motori
Fiat benzina

motori: 0.9 Twinair turbo



1461/C13A € 134,00 1 014610133

240x210x50 mm 1,7 kg

1461/C13B

attrezzi per messa in fase motori
Fiat benzina

Motori: 1.4 Multiair



1461/C13B € 205,00 1 014610134

240x210x50 mm 2,8 kg

1461/C17B

attrezzi per la messa in fase motori
Volkswagen/Audi/Seat e Skoda benzina

Motori: 1.2 TSI



1461/C17B € 114,00 1 014610171

1461/C18B

attrezzi per la messa in fase motori
Volkswagen/Audi/Seat e Skoda benzina

Motori: 1.6-1.8-1.8T, 1.4-1.6-1.8-2.0 16V,
1.4-1.6-2.0 FSI



1461/C18B € 391,00 1 014610182

310x290x120 mm 2,5 kg

Beta

Beta

1461/C20G

attrezzi per la messa in fase motori Fiat Iveco/Peugeot/Citroën/Ford Diesel

Motori: 2.2-2.3-3.0 Multijet



1461/C20G € 678,00 1 014610221
 280x290x100 mm 5,5 kg

1461/C21G

attrezzi per la messa in fase motore Renault Diesel

Motori: 1.6 dCi



1461/C21G € 381,00 1 014610222
 310x290x120 mm 3 kg

1461/C22B

attrezzi per la messa in fase motori Peugeot/Citroën benzina

Motori: 1.0-1.2 VTi



1461/C22B € 350,00 1 014610223
 280x245x75 mm 2 kg

1461/C23B

attrezzi per la messa in fase motori Opel benzina

Motori: 1.0 - 1.2 - 1.4 ecoflex



1461/C23B € 487,00 1 014610224
 280x245x75 mm 2,5 kg

1461/C24B

attrezzi per la messa in fase motori Mini-Peugeot/Citroën benzina

Motori: 1.4 - 1.6 (N12-N14)



1461/C24B € 568,00 1 014610225
 280x245x75 mm 2,8 kg

1461/C25G

attrezzi per la messa in fase motori Mini Diesel

Motori: 1.6 diesel (W16D)



1461/C25G € 127,00 1 014610226
 270x120x45 mm 1 kg

1461/C26B

attrezzi per la messa in fase motori Fiat/Alfa Romeo/Lancia benzina

Motori: 1.2-1.4 8v



1461/C26B € 315,00 1 014610227
 280x245x75 mm 1,7 kg

1461/C27G

attrezzi per la messa in motori Bmw Diesel

Motori: 1.6-2.0D (N47-N47S)



1461/C27G € 228,00 1 014610228
 280x245x75 mm 2 kg

1461/C28B

attrezzi per la messa in fase motori Volkswagen, Seat, Skoda benzina

motori: 1.0 - 1.0 Bluemotion Tech
 1.0 Ecofuel/Ecomotive - 1.0 Green Tech



1461/C28B € 406,00 1 014610229
 280x245x75 mm 1,7 kg

1461/C29B

attrezzi per la messa in fase motori Ford benzina
motori: 1.0 EcoBoost



1461/C29B € 584,00 1 014610209
280x245x75 mm - 2,6 kg

1461/C30G

attrezzi per la messa in fase motori Volkswagen/Audi/Seat e Skoda Diesel

motori: 1.6-2.0 CR TDI
per motori a partire dall'anno 2012



1461/C30G € 528,00 1 014610231
280x245x75 mm - 2 kg

1461/C31B

attrezzi per la messa in fase motori Volkswagen/Audi/Seat e Skoda Benzina

Motori: 1.0-1.2-1.4 TSI/TFSI



1461/C31B € 426,00 1 014610232
270x230x80 mm - 2,1 kg

1461/C32G

attrezzi per la messa in fase motori Opel Diesel
Motori: 1.6 CDTi (B16)



1461/C32G € 259,00 1 014610233
270x230x80 mm - 1,3 kg

1461/C33B

attrezzi per la messa in fase motori Opel benzina

Motori: 1.0 - 1.0 Turbo SIDI Ecoflex



1461/C33B € 85,00 1 014610234

1462CF/C6

serie di 6 chiavi poligonali aperte per raccordi carburante iniettori

misure:
12-14-16-17-18-19 mm



1462CF/C6 € 79,00 1 014620006
260x145x60 mm - 1,2 kg

1462CF

chiavi poligonali aperte per raccordi carburante iniettori



mm	€	1	014620012
12	12,50	1	014620012
14	12,70	1	014620014
16	13,00	1	014620016
17	13,20	1	014620017
19	14,00	1	014620019
18	13,60	1	014620018

1462CF-SN/C6

serie di 6 chiavi snodate esagonali aperte per raccordi carburante iniettori

misure:
12-14-16-17-18-19



1462CF-SN/C6 € 115,00 1 014620026

275x182x64 mm

1462/KD

assortimento utensili per estrazione iniettori Denso completo di massa battente



1462/KD € 695,00 1 014620060
335x210x80 mm - 4,8 kg

1462/KI

assortimento utensili per estrazione iniettori Diesel Common Rail

Permette la rimozione degli iniettori DELPHI-BOSCH-SIEMENS-DENSO



1462/KI € 2.075,00 1 014620235
530x470x140 mm - 2,0 kg

1462/KMRC

assortimento utensili per estrazione iniettori su motori Mercedes 2.1L, 2.2L, 3.0 V6 e Chrysler

Per iniettori Bosch (2.1 e 2.2L) e Delphi (3.0) Si può procedere alla rimozione degli iniettori senza rimuovere il motore.
Particolarmente indicato per i modelli:
Mercedes Vito, Vario, CLK, Sprinter, Viano, Classe M, GL, C, GLK, E, CLS, S, R, G
Chrysler 300 C



1462/KMRC € 590,00 1 014620070
310x300x118 mm - 3,5 kg

1462/KU

assortimento utensili universale per estrazione iniettori diesel common rail completo di pinza e massa battente



1462/KU € 620,00 1 014620100
390x290x100 mm - 4,5 kg

1462AD/BSC

adattatore per estrazione iniettori Bosch Common Rail

da utilizzare con articoli Beta 960KI, 1462KI e Beta 1462/KU



1462AD/BSC € 180,00 1 014620435

1462AD/SMN

kit di adattatori per estrazione iniettori Siemens e Denso

da utilizzare con articolo Beta 960KI/1462KI



1462AD/SMN € 270,00 1 014620436

1462/EI

attrezzo universale a vibrazioni per estrazione iniettori

- Favorisce la rimozione di iniettori fortemente grippati dall'alloggiamento, senza arrecare danni alla testata ed evitando possibili rotture
- Utilizzabile con qualsiasi set di estrazione iniettori con o senza massa battente
- L'attrezzo agisce direttamente con vibrazioni e impulsi sul tirante di estrazione, che è accoppiato con l'iniettore
- Attraverso la valvola di regolazione è possibile adeguare l'intensità della vibrazione in base al tipo di intervento da eseguire.

CE



1462/EI € 549,00 1 014620240

1462PIM

coppia di piastre per manutenzione iniettori bloccaggio in morsa sezioni:
Ø 11-12-13-14-16-19-20 mm



1462PIM € 87,00 1 014620502

1463/KIT

kit attrezzatura per blocco pulegge distribuzione



1463/KIT € 335,00 1 014630001
280x140x75 mm - 1,2 kg

1464T

tester digitale per la misurazione di pressione e compressione

CARATTERISTICHE

- display touch screen da 5"
- batteria ai polimeri di litio ricaricabile
- completo di sensore da 80 bar (basse pressioni) e cavo USB

CE



1464T € 730,00 1 014640050

1464T/SP80

seniore di pressione da 80 bar per 1464T e 960TP



1464T/SP80 € 250,00 1 014640053

960AD/TP2

set di adattatori per 1464T e 960TP in valigetta di plastica



960AD/TP2 € 432,00 1 009600510
430x310x50 mm - 3,2 kg

1464IC

set completo di finti iniettori e finte candele, per 1464T

Permette di collegarsi al motore per la verifica della compressione nei motori diesel con tester digitale 1464T.

Include:

- n° 22 false candele
- n° 5 falsi iniettori
- n° 1 kit falso iniettore universale per auto, truck, motori marini e macchine agricole



1464IC € 490,00 1 014640350

≡ 559x312x50 mm - 4,5 kg

1464IC/RK

kit falso iniettore universale per auto, truck, motori marini e macchine agricole

incluso in art. 1464IC



1464IC/RK € 158,00 1 014640377

≡ 200x110x30 mm - 885 g

1464AP

set per la verifica dell'impianto alta pressione dei motori diesel common rail, per 1464T

Fornito con:

- set tubi alta pressione
- raccordi di collegamento
- sensore da 2.000 bar



1464AP € 660,00 1 014640450

≡ 430x310x50 mm - 1,8 kg

1464AP T

tubo alta pressione per 1464AP e 960TAP



1464AP T12X12	€ 51,50	1	014640453
1464AP T12X14	€ 51,50	1	014640454
1464AP T14X12-M1,0	€ 51,50	1	014640455

1464AP T16X12

tubo alta pressione 16x12 per sistema Bosch CP4, da utilizzare con 1464AP



1464AP T16X12 € 61,00 1 014640456

1464FG

set di falsi regolatori per la verifica del sistema diesel common rail (da utilizzare con Beta 1464T-1464AP)

Utilizzato con il tester e gli adattatori idonei, permette di stabilire se il problema risiede nella pompa alta pressione o nel regolatore in caso di assenza di pressione nel circuito di alta pressione nei motori diesel common rail.

Indicato per regolatori di pressione Bosch, Delphi, Denso e Siemens



1464FG € 255,00 1 014640470

≡ 350x250x80 mm - 1,8 kg

1464FG/CP4

falso regolatore per pompa Bosch CP4 non incluso in 1464FG



1464FG/CP4 € 37,50 1 014640475

1464APB

set per la verifica dell'impianto alta pressione benzina dei motori FSI, per 1464T

Include sensore da 200 bar e raccordi di collegamento



1464APB € 325,00 1 014640500

≡ 240x210x50 mm - 0,5 kg

1464PB

set di 9 connessioni per la verifica della bassa pressione carburante (da utilizzare con 1464T)

Attraverso le connessioni rapide collegate al tester 1464T si effettua rapidamente la verifica della bassa pressione carburante nei motori diesel e benzina



1464PB € 450,00 1 014640700

≡ 530x440x120 mm - 3,8 kg

1464ADB

set per la verifica della pressione dell'impianto AdBlue® per 1464T

Fornito con adattatori da utilizzare con il sensore standard da 80 bar presente nel 1464T



1464ADB € 75,00 1 014640620

≡ 240x210x50 mm - 0,5 kg

 **Beta**
Quality Tools

1464FAP

set per la verifica della pressione del filtro antiparticolato DPf per 1464T

Fornito con:
- sensore da 500 mbar
- adattatore da 8 mm con attacco rapido e raccordo a T
- cavo RJ45 da 3 metri



DATI TECNICI
test della pressione: 0÷500 mbar
risoluzione: 1 mbar

1464FAP € 161,00 1 014640610

240x210x50 mm - 0,5 kg

1464PT

set per la verifica della pressione del turbo, per 1464T

Include sensore da 3bar e cavo di collegamento



1464PT € 142,00 1 014640550

240x210x50 mm - 380 g

1464TDI

set per la verifica della pressione della pompa nei motori TDI, per 1464T

Include raccordo di collegamento



1464TDI € 102,00 1 014640600

240x210x50 mm - 400 g

1464VD

set per verifica della depressione/vuoto per 1464T

Permette la misurazione e memorizzazione del valore massimo della depressione

Fornito con:
- sensore da 800 mbar
- adattatori da 6 e 8 mm
- cavo RJ45 da 3 metri

DATI TECNICI
test del vuoto: 0÷800 mbar
risoluzione: 1 mbar
memorizzazione del valore massimo



1464VD € 161,00 1 014640570

240x210x50 mm

1464PF

set per la verifica della pressione nell'impianto frenante, per 1464T

Include adattatori e raccordi



1464PF € 580,00 1 014640650

400x280x60 mm - 3 kg



1465

strumento di verifica dell'efficienza del motore

Permette di verificare in pochi secondi la compressione dei motori endotermici senza doversi collegare al motore, prelevando l'alimentazione dalla batteria del veicolo, attraverso un software dedicato



CE

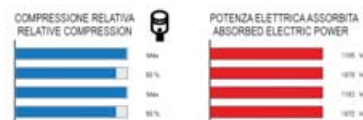

- 1° Fase: calcolo giri/motore
- 2° Fase: analisi andamento tensione batteria durante ogni singolo giro
- 3° Fase: visualizzazione potenza elettrica assorbita e compressione relativa calcolata attraverso il lavoro del motorino di avviamento per ogni pistone
- 4° Fase: verifica stato di carica ed efficienza della batteria

DATI TECNICI

Tensione di funzionamento: 12V DC (batteria veicolo)
Dimensioni: 140x75x30 mm
Lunghezza cavo pinze: 1300 mm
Peso: 365 g

1465 € 975,00 1 014650010

1466/C5

kit 5 chiavi per spurgo freni

inclusi nel kit:

- 5 chiavi misura 7-8-9-10-11 mm
- 1 tubo di scarico con valvola di non ritorno



1466/C5 € 107,00 1 014660100

260x170x50 mm - 600 g

1466L 11

chiave 11 mm per spurgo freni versione lunga



1466L 11 mm 11 mm L 60 € 26,50 1 014660211

1466TLF

tanica per recupero olio freni
capacità 1,5 litri

Attacco rapido per tubo di spurgo Ø 5,5 mm



1466TLF € 38,50 1 014660201

1467

strumento estrazione liquido freni



Pressione min 5 bar, Max 11,5 bar

1467 1,5 € 285,00 1 014670001

1467/RK1

kit tubo di ricambio per 1467



1467/RK1 € 21,50 1 014670501

1467/RK2

rabboccatore di ricambio per 1467



1467/RK2 € 82,00 1 014670502

1467LF/2

strumento elettrico per sostituzione
liquido freni
dotato di "effetto pulsante"



"Effetto
pulsante"

- stop automatico con tanica vuota, che impedisce l'inserimento di aria
 - volume massimo tanica: 20L
 - pressione di esercizio: 0,4+3,5 bar
 - alimentazione 230V
- Dotazione inclusa:
- tanica di recupero olio dai freni
 - 1 tappo E20 standard

1467LF/2 € 1.485,00 1 014670099

1467LF/RC

contenitore con tubo di recupero per 1467LF



1467LF RC € 90,00 1 014670125

1467TU

tappo per vaschette
liquido freni

- adattabile al 90% delle vaschette del parco circolante
- utilizzabile con articolo Beta 1467LF



1467TU € 56,00 1 014670090

1468N

attrezzi per sostituzione
piattelli valvole

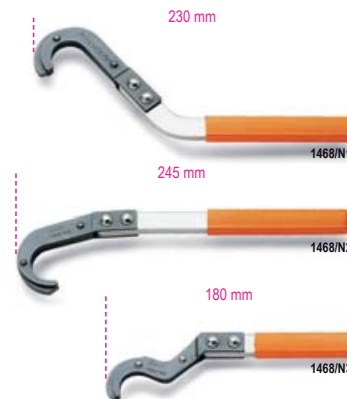

1468N/1	€ 20,50	1	014680011
1468N/2	€ 21,00	1	014680012
1468N/3	€ 21,50	1	014680013

1470

pinze per molle freni
a tamburo



L mm	€		
210	33,50	1	014700001
330	42,50	1	014700002
540	128,00	1	014700010

1470FT

pinza per fermi molle ceppi freni a tamburo

Becchi inclinati a 40°
Accesso facilitato nei punti scomodi



L mm	€		
184	35,00	1	014700000

1470PF

attrezzo per la sostituzione dei cilindri
nei freni a tamburo

le ganasce restano divaricate, ed il cilindro
viene facilmente sostituito



A mm	€		
25÷140	64,00	1	014700200

1471

pinza per molle freni a tamburo



L mm
330 € 65,00 1 014710001

1471A

pinza per cavo freno a mano



A max mm 45 B mm 5 € 79,00 2 014710010

1471GF

coppia di ganci modellabili per il sostegno della pinza freno durante la sostituzione delle pastiglie



Max kg 5 € 12,00 1 014710310

1471M/C22

utensile pneumatico per arretrare e ruotare i pistoncini dei freni a disco destrorsi e sinistrorsi con accessori

- martinetto automatico
- 150 Kg di spinta
- pressione di utilizzo 5÷8 bar



1471M/C22 € 255,00 1 014710101

350x310x85 mm - 3,5 kg

1471M/50

martinetto pneumatico per arretrare e ruotare i pistoncini dei freni a disco destrorsi e sinistrorsi

- martinetto automatico
- 150 Kg di spinta
- pressione di utilizzo 5÷8 bar

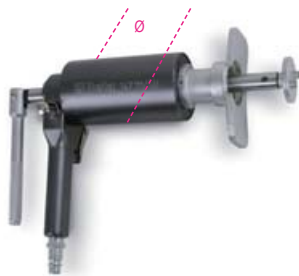

Ø mm 50 Kg 150 Bar 5÷8 € 140,00 1 014710069

1471M/P

adattatore per pastiglie usurate e pinze TRW-Mégane



1471M/P € 21,80 1 014710080

1471M/W50

adattatore per freno stazionamento VW Passat ≥ 2005



1471M/W50 € 7,60 1 014710079

1471PN/B1

adattatore per freno stazionamento Ford



1471PN/B1 € 7,60 1 014710081

1471PN/B2

adattatore per freno stazionamento Daily



1471PN/B2 € 10,70 1 014710082

1471PN/B3

adattatore per freno stazionamento BMW



1471PN/B3 € 7,60 1 014710083

1471PN/B4

adattatore per freno stazionamento BMW

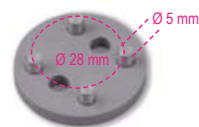

1471PN/B4 € 7,60 1 014710084

1471PN/B5

adattatore per freno stazionamento Mini/ BMW



1471PN/B5 € 6,60 1 014710085

1471CF

chiavi a bussola a mano bocca pentagonale per dadi pinze freno



mm 14 € 14,80 1 014710314
19 € 14,80 1 014710319

1471CM

chiave a bussola maschio pentagonale per viti pinze freno



mm 10 € 14,80 1 014710360

1471CM/E11

chiave a bussola maschio esagonale 11 mm per viti pinze freno Mercedes ML (serie 166)



mm	mm	mm	mm	€		
11	24	75	15,5	15,80	1	014710361

1471D2

arretrato pistoncini freni a disco anteriori con pinze chiuse

doppia coppia di piastre per operare su pinze a 2 e 4 pistoncini



mm	€		
10	66,00	1	014710301

250x170x60 mm 1,5 kg

1472

pinza per anelli stringitubo



1472	€		
	37,50	1	014720001

1472AU

pinza automatica per anelli stringitubo



mm	€		
18+53	109,00	1	014720100

1472R/AU

puntali di ricambio per pinza 1472AU



1472AU/R	€		
	41,50	1	014720101

1472AU/P

pinza automatica con prolunga per anelli stringitubo



mm	mm	€		
18+54	630	96,00	1	014720105

1472AU/RP

cavo di ricambio per pinza 1472AU/P



1472AU/R	€		
	23,50	1	014720106

1472FC

pinza con teste orientabili, per fascette Clic®



1472FC	€		
	34,50	1	014720090

1472FC/GE

pinza a grande effetto, per fascette Clic®

particolarmente indicata per fascette di grandi dimensioni



L mm	€		
230	60,50	1	014720093

1472FC/L

pinza con prolunga flessibile a testa orientabile a 360°, per fascette Clic®



L mm	€		
630 mm	92,00	1	014720095

1472FCL/RP

cavo di ricambio per pinza 1472FC/L



1472FCL/RP	€		
	40,50	1	014720096

1472FCA

pinza per rimozione fascette con cremagliera tipo Visa®



1472FCA	€		
	52,00	1	014720041

1472H

attrezzo per rimozione fascette Henn



L mm	€		
100	20,30	1	014720000

1472MT/VW

coppia di graffe per scollegamento collettori di aspirazione gruppo VAG Utilizzabile su motori turbo benzina 1.0 - 1.2 - 1.4



1472MT/VW	€		
	9,70	1	014720500

1472TM

pinza per scollegare i raccordi rapidi dei filtri multijet



1472TM € 24,00 1 014720200

1472VW

pinza con teste orientabili per fascette stringitubo per vetture del gruppo Volkswagen e Mercedes



1472VW € 39,00 1 014720051

1473

pinza per collari OETIKER®



1473 275 € 107,00 1 014730001

1473A

pinza con reggiasola per collari OETIKER®



1473A € 81,50 1 014730010

1473Q

pinza con quadro di manovra, per collari OETIKER®

Utilizzabile con:
• chiavi dinamometriche
• cricchetti
• quadri maschi di manovra

38"



1473Q € 75,00 1 014730005

1473P

pinza per collari OETIKER® pinzabili a basso profilo



A Max
mm
53

1473P € 30,50 1 014730020

1473FN

attrezzo per serraggio e taglio fascette a nastro in acciaio inox

utilizzabile con fascette Panduit® e similari



A mm
4,7÷9,5 € 56,00 1 014730501

1473T

tronchese per rimozione fascette in acciaio permette di tagliare le fascette senza rischiare il danneggiamento di cuffie, manicotti, ecc.



A Max mm 14 L mm 220 € 50,50 1 014730582

1474/C4

kit 4 utensili estrazione bobine candele Volkswagen



1474/C4 € 85,00 1 014740100

290x190x50 mm - 1 kg

1474E/VW

estrattore ad espansione per bobine accensione gruppo Volkswagen



1474E/VW € 23,30 1 014740120

1474E/VW2

estrattore bobine accensione gruppo VAG utilizzabile su motori 1.0 - 1.2 - 1.4 - 2.0



1474E/VW2 € 29,00 1 014740150

1474L

pinza per cappucci candele d'accensione a becchi lunghi piegati 15°

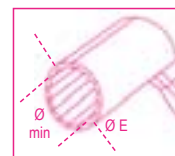

Ø min mm 14 Ø E mm 20 € 68,00 2 014740010



1474DL

pinza per cappucci candele d'accensione a becchi lunghi manici ricoperti con 2 strati in PVC



1474DL € 33,00 1 014740015

1474G

pinza a becchi lunghi piegati per cappucci candellette di preriscaldamento



1474G € 37,00 1 014740200

1475U

pinza universale cromata lucida con impugnatura a "pistola" manici ricoperti con 2 strati in PVC



1475U € 34,50 1 014750010

1476

pinza regolabile autobloccante per taglio tubi di scarico



Ø min mm 19 Ø max mm 75 L mm 225 € 66,00 1 014760002

1476/RC

catena di ricambio per 1476



1476/RC € 32,50 1 014760012

1476A

pinza per taglio tubi di scarico



Ø min mm 30 Ø max mm 95 € 84,00 1 014760005

1476A/RC

catena di ricambio per 1476A



1476A/RC € 72,00 1 014760015

1476C/1

attrezzi espansori per tubi di scarico



1476C/1 € 32,00 1 014760101
Ø 30÷42 mm
L = 131 mm
L1 = 51 mm

1476GT

pinza per rimozione supporti in gomma per tubi di scarico



L mm 280 A Max mm 58 S mm 3 € 29,50 1 014760050

1476PSA

pinza per fascette di scarico con perno, gruppo PSA
la forma dei becchi e il blocco automatico della cremagliera permettono di operare senza sfilare il perno



L mm 309 A Max mm 60 S mm 12,2 € 35,50 1 014760060

1476T

chiave per smontaggio/montaggio turbine su motori diesel, gruppo Volkswagen Audi



mm 12 € 32,50 1 014760200

1477/C10

chiave curva con 9 inserti per dadi tendicinghia

1 chiave curva con attacco per inserti
4 inserti poligonali doppi: 12x14 - 13x15 - 16x17 - 18x19 mm
5 inserti per viti con profilo Torx: E10 - E12 - E14 - E16 - E18



1477/C10 € 138,00 1 014770310

530x110x55 mm

1477D

chiavi poligonali per dadi tendicinghia



mm 13 € 24,50 1 014770113
15 € 24,50 1 014770115
16 € 24,50 1 014770116
17 € 24,50 1 014770117
19 € 24,50 1 014770119

1477D/S5

serie di 5 chiavi poligonali per dadi tendicinghia

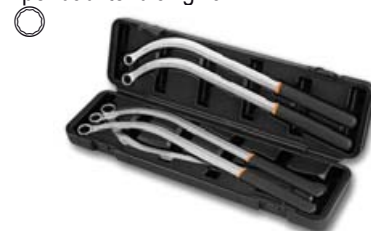

1477D/S5 € 122,50 1 014770200

13-15-16-17-19 mm

600x200x70 mm - 2,2 kg

1477K/7

kit chiave curva a cricchetto reversibile con inserti



- 2 Inserti Torx® T40-T45
- 1 Inserto XZN® 10
- 1 Inserto esagonale 8 mm
- 3 Inserti poligonali 10-12-13 mm

L
mm
250 € 120,00 1 014770051

1478

pinza per estrazione pioli



€ 47,50 1 014780001

1478T

pinza con testa orientabile per pioli in plastica con clips a pressione

testa orientabile a 90°



S
mm
4,5 € 37,50 1 014780101

1478/3P

pinza per pioli in plastica con 3 punti di sblocco



€ 53,00 1 014780151

1479

estrattore per pioli

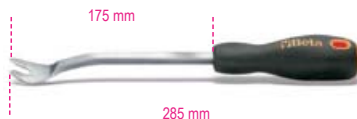

1479 € 21,00 2 014790001

1479/B27

kit di 27 attrezzi in nylon per pioli e interventi su plastiche e guarnizioni in busta appendibile



1479/B27 € 66,00 1 014790407

1479LB/C5

kit di 5 levapioli in metallo



1479LB/C5 € 89,00 1 014790150

215x165x50 mm

1479L/S2

coppia di leverini multifunzione in Teflon®



1479L/S2 € 30,00 1 014790510

1479LV/S3

kit di 3 leverini multifunzione in metallo

misure:
1479LV/1: 10x12 mm
1479LV/2: 4,8x9,6 mm
1479LV/3: 2,8x6 mm



1479LV/S3 € 25,00 1 014790100

1479ML/B17

kit di 17 leverini multifunzione in materiale plastico particolarmente adatti per lavori di precisione



1479ML/B17 € 54,00 1 014790700

1479ML/S3

kit di 3 leverini multifunzione in materiale plastico

Particolarmente adatti per lavori di precisione



1479ML/S3 € 9,20 1 014790603

1479N/S5

kit di 5 levapioli in nylon



1479N/S5 € 34,00 1 014790251

1479RB/1

raschietto a battere tipo diritto



1479RB/1 € 23,50 1 014790315

1479RB/2

raschietto a battere tipo piegato



1479RB/2 € 23,50 1 014790320

1479RB/3

raschietto a battere tipo piatto



1479RB/3 € 26,50 1 014790310

1479U/13

levapioli lama inox



1479U/13 € 21,50 2 014790010

1479U/32

levapioli lama inox



1479U/32 € 25,00 2 014790015

1480

kit riempimento filtri gasolio
per auto senza pompa elettrica

• Utilizzabile anche con pistola gonfiagomme

Il kit include:

- attacchi rapidi GM
- attacchi rapidi Renault, GM, Fiat Ø interno 6 mm
- attacchi rapidi Renault, GM, Fiat Ø interno 7 mm
- attacchi rapidi Ford
- attacchi rapidi PSA Ø interno 6mm
- attacchi rapidi PSA Ø interno 7 mm
- attacchi rapidi Ford
- 2 adattatori conici per vetture senza attacchi rapidi



1480 € 319,00 1 014800010

410x320x70 mm

1481/C12

kit 6 coppie pinze per
occlusione tubazioni

- 2 coppie differenti pinze misura 1/4"
- 2 coppie differenti pinze misura 3/8"
- 2 coppie differenti pinze misura 5/16"
- 3 coppie tappi in gomma



1481/C12 € 101,00 1 014810312

370x270x59 mm

1481K/S4

kit di 4 morsetti autoserranti
per occlusione linee

misure:
5/16" - 3/8" - 1/2" e passante



1481K/S4 € 25,00 1 014810400

1481PL/A

pinza in plastica per occlusione tubi
e manicotti

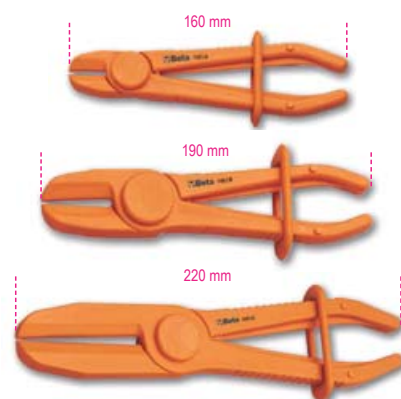

1481PL/A	Ø mm	€	1	014810110
1481PL/A	8÷15	17,30	3	014810110
1481PL/B	15÷25	19,30	3	014810120
1481PL/C	25÷45	26,00	3	014810130

1481PL/S3

serie di 3 pinze in plastica
per occlusione tubi e manicotti



1481PL/S3	€	1	014810200
1481PL-A Ø 8÷15 mm	62,50	1	014810200
1481PL-B Ø 15÷25 mm			
1481PL-C Ø 25÷45 mm			

1482

chiave regolabile autoserrante
per ghiera galleggianti serbatoio



Ø mm	€	1	014820001
89÷170	93,50	1	014820001
89÷200	98,00	1	014820002



1482A/1

chiave a 3 zampe per ghiera galleggianti serbatoio con ghiera in alluminio

per agire sulla ghiera in alluminio montata dal 2011 su vetture dei gruppi Fiat, Volkswagen, Opel, Chevrolet, Mercedes e BMW



Ø mm 185 € 65,00 1 014820005

1482A/3

chiave per ghiera galleggianti serbatoio gruppo PSA

il disegno permette di operare sull'asse decentrato rimuovendo la ghiera, senza danneggiare il delicato pescante



Ø mm 157 € 74,00 1 014820007

1482A/5

chiave per ghiera galleggianti serbatoio a 22 settori

per agire sulla ghiera in plastica montata sulle vetture del gruppo VAG



Ø mm 180 € 57,00 1 014820015

1482/8 - 1482/10

pinze per raccordi rapidi tubi carburante

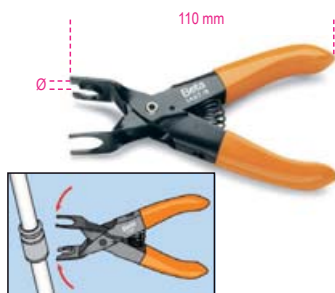

	Ø mm	€		
1482/8	8	32,50	2	014820008
1482/10	10	32,50	2	014820010

1482B

pinza per raccordi rapidi tubi carburante



1482B € 39,00 1 014820021

1482C

2 coppie di cunei per sgancio raccordi filtri gasolio gruppo Fiat, Volkswagen, Jeep, Chrysler e Volvo

rapida sostituzione del filtro senza danneggiare irrimediabilmente i raccordi



1482C € 51,50 1 014820022

1482D

pinza con prolunga flessibile per raccordi rapidi tubi carburante



1482D € 71,00 1 014820026

1483K/12

kit per smontaggio valvole impianto aria condizionata con serie di inserti pentalobati

Il kit include:

- 2 bussole femmina ottagonali Ø 12 e 15 mm per valvole alta pressione
- 2 bussole maschio a forchetta sezione 2,2 e 3,2 mm per valvole a farfalla
- 1 serie di inserti pentalobati misura: PT10, PT15, PT20, PT25, PT27, PT30, PT40



1483K/12 € 34,00 1 014830012

120x80x35 mm

1483KV-PT/S7

serie di inserti pentalobati

misure include:

PT10 - PT15 - PT20 - PT25 - PT27 - PT30 - PT40



1483KV PT/S7 € 10,30 1 014830117

1483K/22

kit per la separazione di raccordi su impianti di condizionamento, alimentazione e lubrificazione



1483K/22 € 117,00 1 014830022

300x230x55 mm - 1 kg

1484

set di 2 utensili per la rimozione e il montaggio delle cinghie elastiche

Permette una rapida rimozione e un corretto montaggio della cinghia elastica senza rischio di danneggiamento



1484 € 103,00 1 014840010

1484PSA

attrezzo per il montaggio della cinghia elastica della pompa dell'acqua senza tendicinghia

utilizzabile per gruppo PSA e Opel motori 1.0 - 1.2



1484PSA € 13,50 1 014840012

1485BP

attrezzo a mezzaluna per bloccare pulegge dentate

regolabile tramite manico girevole, stringe e blocca la puleggia dall'esterno, evitando danni ai sensori circostanti



A Max mm 130 € 184,00 1 014850000

1485BPM

attrezzo a mezzaluna con ganasce in alluminio per bloccare pulegge multigola

regolabile tramite manico girevole, stringe e blocca la puleggia dall'esterno, evitando danni ai sensori circostanti



A Max mm 180 € 159,00 1 014850002

1485FCA/K2

coppia di attrezzi per precaricare cuscinetti cinghia di distribuzione gruppo FCA indicati per motori 1.2, 1.4 8/16 V e 1.4 Multiair

- 1 attrezzo lungo 175 mm con puntali da 13,5 mm
- 1 attrezzo lungo 305 mm snodato con puntali da 13,5 mm



1485FCA/K2 € 85,00 1 014850220

1485FCA/T

attrezzo snodato per precaricare cuscinetti cinghia di distribuzione del gruppo FCA



L mm 175 P mm 13,3 € 31,00 1 014850210

1485FCA/TS

attrezzo per precaricare cuscinetti cinghia di distribuzione del gruppo FCA



L mm 305 P mm 13,5 € 54,00 1 014850215

1485FRD/T

leva per il tensionamento delle cinghie dei servizi, montate su motori Ford utilizzabile per la rimozione delle pulegge degli alternatori



L mm 450 Q mm 12,80 € 66,00 1 014850310

1485MRC/T

leva per il tensionamento delle cinghie dei servizi, montate su motori Mercedes utilizzabile per motori M133 - M270

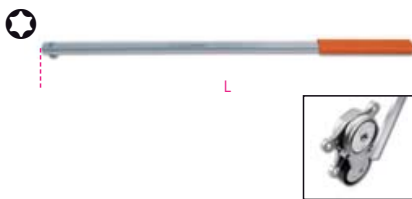

L mm 510 Ø T55 € 27,00 1 014850315

1485VLV/T

leva per il tensionamento delle cinghie dei servizi, montate su motori Volvo

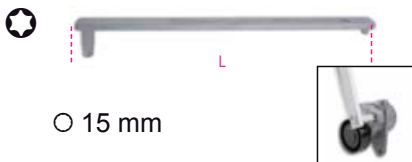

L mm 420 Ø T50-T60 15 € 55,50 1 014850320

1485TC

leva per il tensionamento delle cinghie dei servizi, montate su motori Ford, PSA, FCA



L mm 475 € 40,00 1 014850330

1485/KIT

kit attrezzi per controllo tensione cinghia distribuzione



1485/KIT € 149,50 1 014850100
230x140x75 mm - 580 g

1485MJ

attrezzo bloccaggio albero a camme motori 1.3 16V Multijet

2 teste con 3 profili per operare su tutti i motori 1.3 16V Multijet montati da gruppo FCA, Opel, Ford e Suzuki



1485MJ L mm 500 € 103,00 1 014850150

1485PMTJ

leva sbloccaggio pulegge albero motore Multijet

geometria appositamente studiata per bloccare l'albero motore durante le operazioni di rimozione della puleggia



L mm 450 € 108,00 1 014850190

1485R

attrezzo per rotazione pulegge distribuzione
in acciaio forgiato
con 2 coppie di puntali



Ø mm 30±120
Ø1 mm 10 - 17
L mm 500
€ 129,00
1 014850025

1485R/P10

coppie di puntali



1485R/P10
€ 13,80
1 014850035

1485R/P17

coppie di puntali



1485R/P17
€ 13,80
1 014850038

1485VAG/K2

coppia di attrezzi per precaricare
i cuscinetti cinghia di distribuzione

- testa orientabile in 3 posizioni
- 1 attrezzo con testa profonda 12,5 mm
- 1 attrezzo con testa profonda 21,5 mm



1485VAG/K2
€ 64,00
1 014850080

1485VAG

attrezzi per precaricare
cuscinetti cinghia di distribuzione

- testa orientabile in 3 posizioni



L mm P mm
1485VAG/12,5 190 12,5 € 32,00 1 014850062
1485VAG/21,5 195 21,5 € 32,50 1 014850071

1486/10

chiave per valvole bombole metano

- gruppo VW dal 2008
- Panda dal 2004 al 2012
- Grande Punto dal 2005 al 2012
- Ducato dal 2010
- nuovi Doblò e Combo
- Cubo e Fiorino



36 mm

1486/10 € 116,00 1 014860110

1486/20

chiave per valvole bombole metano

- Multipla
- Ducato 1ª e 2ª serie fino al 2010
- Berlingo e Ranch
- C3 con bombole in ferro
- Punto dal 1999 al 2010
- Doblò 1ª serie
- Daily e gruppo Iveco
- Dr5



36 mm

1486/20 € 116,00 1 014860120

1486/30

chiave per valvole bombole metano

- Zafira 2ª serie
- Combo 1ª serie

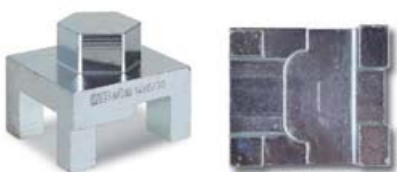

36 mm

1486/30 € 116,00 1 014860130

1486/40

chiave per valvole bombole metano

- Touran 1ª serie

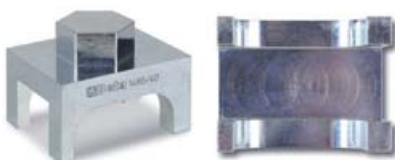

36 mm

1486/40 € 116,00 1 014860140

1486/50

chiave per valvole bombole metano

- Panda dal 2012
- Nuova Ypsilon

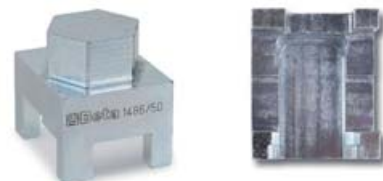

36 mm

1486/50 € 116,00 1 014860150

1486/60

chiave per valvole bombole metano

- C4 Picasso
- impianti BRC



36 mm

1486/60 € 116,00 1 014860160

1486/70

coppia di chiavi per valvole bombole metano

- C3 con bombole in composito

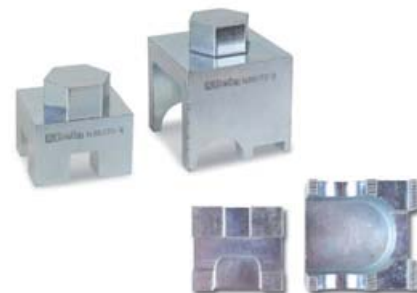

36 mm

1486/70 € 240,00 1 014860170

1486/80

chiave per valvole bombole metano

- Classe B
- Zafira 3ª serie

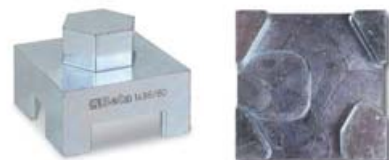

36 mm

1486/80 € 116,00 1 014860180

1486/90

chiave per valvole bombole metano

- Zafira 1ª serie
- Kangoo 1ª serie
- Sprinter

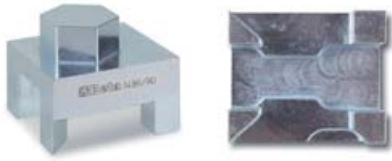

36 mm

1486/90 € 116,00 1 014860190

1488 - 1488L

chiave snodata a catena doppia per filtri olio



1488	60÷110	€ 77,00	1	014880001
1488L	60÷160	€ 85,00	1	014880050

1488/1

chiave a catena doppia sottile per filtri olio



1488/1	60÷110	€ 89,00	1	014880010
--------	--------	---------	---	-----------

1488R...

catena di ricambio



1488RC	1488	350	€ 32,00	1	014880101
1488R/L	1488/L	520	€ 51,00	1	014880150
1488R/1	1488/1		€ 44,50	1	014880110

1489/31T

chiave per ruota libera puleggia alternatore



1489/31T	T50	15	31	€ 32,50	1	014890016
----------	-----	----	----	---------	---	-----------

1489/33

chiave per ruota libera puleggia alternatore Bosch



1489/33	33	€ 13,80	1	014890010
---------	----	---------	---	-----------

1489/33P

chiave per ruota libera puleggia nuovo alternatore Bosch FIAT Grande Punto



1489/33P	M10	15	31	€ 41,00	1	014890015
----------	-----	----	----	---------	---	-----------

1489/E

chiave per ruota libera puleggia alternatore



1489/E	10	15	€ 28,00	1	014890025
--------	----	----	---------	---	-----------

1489R

chiave per ruota libera puleggia alternatore Renault



1489/R	€ 13,80	1	014890020
--------	---------	---	-----------

1489/Y

chiave per ruota libera puleggia alternatori Nippondenso



1489/Y	32	€ 15,80	1	014890040
--------	----	---------	---	-----------

1489/C14

assortimento di 14 utensili per le pulegge libere degli alternatori



1489/C14	€ 245,00	1	014890100
----------	----------	---	-----------

- 867PE 8 mm
- 867PE/L 8 mm
- 867XZN/L M10
- 867TX/L T50
- 867/2 1/2"
- 920B 10 mm
- 1489/33
- 1489/33P M10
- 1489R
- 1489/Y
- 1489/31T T50
- 1489/E 10 mm
- 188 10 mm
- 188 15 mm

420x250x45 mm - 1,9 kg

1490

chiavi a nastro per filtri olio

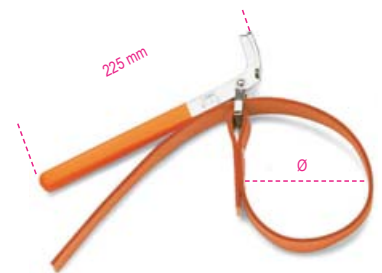

1490/1	160	€ 31,00	1	014900001
1490/2	240	€ 33,50	1	014900002

1490/R1 - 1490/R2

nastri in tessuto di ricambio per 1490



1490/R1	160	€ 14,80	1	014900101
1490/R2	240	€ 18,30	1	014900102

1490F

chiavi a fascia per filtri

38"

12"



Ø Max mm	€		
200	22,50	1	014900201

1491

chiave a nastro metallico regolabile per filtri olio



Ø mm	€		
65÷110	40,00	2	014910001

1491R

nastro metallico di ricambio per 1491



1491R	€		
	7,20	10	014910010

1491A

pinza regolabile per filtri olio

Regolazione di precisione mediante cremagliera



L mm	Ø min - Max mm	€	
345	55 ÷ 140	27,00	1 014910040

1491T

pinza regolabile per filtri olio truck

Regolazione di precisione mediante cremagliera
Utilizzabile per filtri essiccatori



L mm	Ø min - Max mm	€	
500	70÷200	63,00	1 014910050

1492/1 - 1492/2

chiavi regolabili per filtri olio



	Ø mm	€	
1492/1	60÷80	38,00	1 014920001
1492/2	80÷110	39,50	1 014920002

1492T

chiavi per filtri essiccatori

12"



	Ø mm	H mm	€	
1492T 40	125÷145	40	29,50	1 014920540
1492T 75	120÷140	75	50,50	1 014920575

1493B

chiavi poligonali per cartucce filtri olio di difficile accesso

38"



mm	± mm	€	
24	8	16,30	1 014930524
27	8	16,90	1 014930527
32	8	17,40	1 014930532
36	8	18,50	1 014930536
38	8	19,00	1 014930538

1493B/S5

serie di 5 chiavi poligonali per cartucce filtri olio di difficile accesso

misure:
24-27-32-36-38 mm

38"



1493B/S5	€		
	67,00	1	014930599

1493

chiave a bussola per filtri olio

N=numero lati

12"



Ø mm	N	€	
65	14	9,20	1 014930200
68	14	9,20	1 014930206
73	14	9,20	1 014930208
74	14	9,20	1 014930209
74	15	9,20	1 014930210
75-77	15	9,20	1 014930212
76	8	9,20	1 014930214
76	14	9,20	1 014930218
76-74	15	9,90	1 014930220
78	15	9,90	1 014930224
80	15	10,20	1 014930226
82-80	15	10,20	1 014930228
86	16	10,80	1 014930230
90	15	10,80	1 014930234
92	10	10,80	1 014930236
93	15	10,80	1 014930238
95	15	10,80	1 014930244
100	15	12,30	1 014930248
106	15	12,80	1 014930250
108	15	12,80	1 014930252
135	18	20,50	1 014930256

1493/PF

chiavi a bussola per filtri olio Purflux

N=numero lati

12"



Ø mm	N	€	
66	6	9,20	1 014930202
76	12	9,20	1 014930216
76	30	9,90	1 014930222
86	18	10,80	1 014930232
93	36	10,80	1 014930240
93	45	10,80	1 014930242
96	18	10,80	1 014930246
108	18	13,80	1 014930254



Beta

1493/C30

serie di 28 chiavi a bussola per filtri olio

12"



Misure incluse nel kit (Ø mm / n° lati)

1493:
65/14 - 67/14 - 68/14 - 73/14 - 74/15
76/15 - 75.77/15 - 76/14 - 76/8 - 78/15 - 80/15
82/15 - 86/16 - 90/15 - 92/10 - 93/15 - 95/15
100/15 - 106/15 - 108/15

1493PF (Purflux)

66/6 - 76/12 - 76/30 - 86/18
93/36 - 93/45 - 96/18 - 108/18

- inclusa 1 chiave regolabile universale
Ø 65÷120 mm

1493/C30 € 223,00 1 014930000

530x400x110 mm - 4 kg

1493AL

chiavi a bussola per filtri olio

N= numero lati

38"

12"



Ø mm	N	●	□	€	1	014930310
64	14	27	1/2"	13,80	1	014930310
66,5	14	27	1/2"	12,30	1	014930315
74	14	27	1/2"	14,80	1	014930320
79	15	27	3/8"	13,80	1	014930325
84	14	27	3/8"	14,80	1	014930330
87	16	27	1/2"	18,50	1	014930335
92	15	27	3/8"	14,80	1	014930340
94,5	15	27	3/8"	14,80	1	014930345
100,5	15	27	3/8"	14,80	1	014930350

1493AL 4S

chiavi a bussola per filtri olio per auto asiatiche
profilo a 4 settori

38"

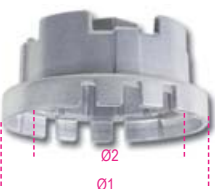

Ø1 mm	Ø2 mm	●	€	1	014930304
70	64,5	27	14,80	1	014930304
80	64,5	27	13,80	1	014930305

1493AL CF

chiavi a bussola esagonale per cartucce filtri olio

12"



Ø mm	H mm	●	€	1	014930424
24	34	27	8,90	1	014930424
27	34	27	8,90	1	014930427
30	34	27	8,90	1	014930430
32,5	34	27	9,20	1	014930432
36	34	27	9,20	1	014930436
38	34	27	9,20	1	014930438

1493/C19

serie di 18 chiavi a bussola per filtri olio.
particolarmente indicate per auto asiatiche

Misure incluse nella serie:

Ø mm	N lati
63-64	14
66,5	14
74	14
79	15
84	14
87	16
92	15
94,5	15
100,5	15
70	14 a settori per Toyota
80	14 a settori per Lexus

N° 6 bussole esagonali misura 24-27-30-32,5-36-38 mm per cartucce filtro
Il kit include 1 chiave regolabile universale Ø 58÷93 mm

12"

38"



1493/C19 € 196,00 1 014930019

490x450x60 mm - 4 kg

1493DSG

chiave per smontaggio/montaggio filtro olio cambio DSG

12"



Ø mm 24 € 31,50 1 014930800

1493FF

chiave per smontaggio/montaggio della sede in plastica di filtri olio Ford Peugeot Citroën motori: TDCi-HDi

permette di serrare correttamente la sede in plastica con chiave dinamometrica a 25 Nm.

12"

12"



Ø mm 27 € 25,00 1 014930127

1493FT

chiave per filtri gasolio Ford Transit

Utilizzabile su tutte le versioni Transit, Transit Custom e Tourneo Custom dal 2012

12"



Ø mm 115 € 21,30 1 014930085

1493J

chiave per filtri gasolio Multijet

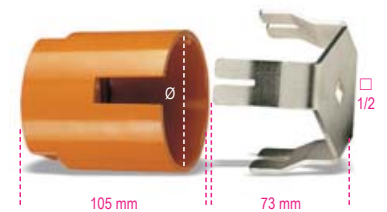

Ø mm 90 € 98,00 1 014930080

1493VW

chiave per filtri gasolio gruppo VAG e Volvo

12"



Ø mm 82,5 € 14,20 1 014930086

1493/C7

chiave autoregolabile a tre bracci per filtri olio destrorsa-sinistrorsa, con bracci intercambiabili

finitura diamantata antiscivolo

2 serie di bracci:

- 1 serie con lunghezza utile 20 mm
- 1 serie con lunghezza utile 38 mm



	Ø mm	○ mm	€		
1493/C7	50÷100	16	95,00	1	014930079

210x150x50 mm

1493H

chiave autoregolabile a tre bracci per filtri olio destrorsa-sinistrorsa

Griffe godronate

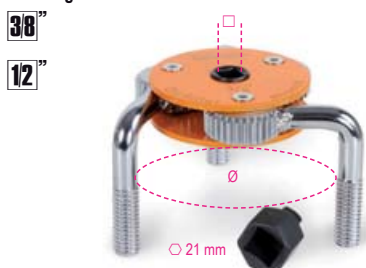

	Ø mm	€		
1493H	72÷127	23,50	1	014930077

1493/S-U

chiave autoregolabile a tre bracci per filtri olio destrorsa-sinistrorsa



	□ mm	Ø mm	€		
1493/S	3/8-1/2	80-115	71,50	1	014930074
1493/U	1/2	105-165	155,00	1	014930076

1493X

chiavi autoserranti per filtri olio sinistrorse



	Ø mm	± mm	€		
1493X/1	60÷80	2,9	27,00	1	014930105
1493X/2	80÷98	2,9	27,00	1	014930110

1493Y

chiavi autoserranti per filtri olio destrorse-sinistrorse versione pesante

l'articolo 1493Y/2 è utilizzabile anche per i filtri essiccatori



	Ø mm	± mm	€		
1493Y/1	80÷110	7,3	92,00	1	014930120
1493Y/2	104÷145	7,3	140,00	1	014930122

1494

chiave a bussola quadrata per tappi olio motore



	mm	€		
1494	10	7,70	1	014940280

1494BMW

chiave speciale per tappi olio in plastica motori BMW



	mm	€		
1494BMW	10	11,80	1	014940315

1494FPC

chiave speciale per tappi olio in plastica motori Ford, Peugeot, Citroën



	mm	€		
1494FPC	10	13,30	1	014940320

1494E

chiavi a bussola maschio esagonale per tappi olio motore



	mm	€		
1494E	8	7,70	1	014940208
1494E	9	7,70	1	014940209
1494E	10	7,70	1	014940210
1494E	11	7,70	1	014940211
1494E	12	7,70	1	014940212
1494E	14	7,70	1	014940214
1494E	17	7,70	1	014940217

1494Q

chiavi a bussola maschio quadrato per tappi olio motore



	mm	€		
1494Q	8	7,70	1	014940258
1494Q	9,5	7,70	1	014940259
1494Q	12	7,70	1	014940262
1494Q	13	7,70	1	014940263

1494T

chiave a bussola maschio triangolare per tappi olio motore



	mm	€		
1494T	9,5	7,70	1	014940289

1494XZN

chiave a bussola maschio con profilo XZN® per tappi olio motore



	M	€		
1494XZN	16	9,20	1	014940296

1494VW

chiave speciale per tappi olio in plastica motori gruppo Volkswagen

permette di rimuovere e installare il tappo in plastica dalla coppa dell'olio. Specifico per vetture del gruppo Volkswagen con motori TFSI e TDI



	mm	€		
1494VW	10	18,50	1	014940305

1494VW/K

kit per sostituzione olio motore gruppo VAG



Contenuto del kit:

- 1 chiave speciale per tappi in plastica
- 6 tappi in plastica per coppa

1494VW/K € 23,90 1 014940310

1494/C14A

assortimento di 14 utensili per cambio olio

12"



1494/C14A € 109,00 1 014940150

- 1494E 8-9-10-11-12-14-17
- 1494Q 8-9,5(3/8")-12-13
- 1494 10
- △ 1494T 9,5(3/8")
- 1494XZN M16

380x305x40 mm - 1,7 kg

1494M

attrezzo per tappi olio esagonali magnetico e flessibile

permette di svitare il tappo senza rischi di scottature e senza sporcarsi



L mm 293 F kg 2,5 Ø mm 19 € 19,80 1 014940401

1495/C6

assortimento di utensili per la riparazione dei filetti della coppa olio



• Il filetto danneggiato viene rimosso con il maschio filettato e allargato di una misura

• Consente la riparazione ed evita la sostituzione della coppa olio

Composto da:

- 1 maschio M13x1.25 + 6 viti + 12 rondelle
- 1 maschio M13x1.5 + 6 viti + 12 rondelle
- 1 maschio M15x1.5 + 6 viti + 12 rondelle
- 1 maschio M17x1.5 + 6 viti + 12 rondelle
- 1 maschio M20x1.5 + 6 viti + 12 rondelle
- 1 maschio M22x1.5 + 6 viti + 12 rondelle

1495/C6 € 235,00 1 014950500

420x185x60 mm - 2,1 kg

1495M

maschio per filetti tappi olio



M	€	1	014950553
13x1,25	14,30	1	014950553
13x1,50	11,80	1	014950563
15x1,50	12,80	1	014950565
17x1,50	14,30	1	014950567
20x1,50	15,80	1	014950570
22x1,50	20,40	1	014950572

1495T

kit di 6 tappi olio e rondelle



M	€	1	014950503
13x1,25	16,80	1	014950513
13x1,50	16,80	1	014950513
15x1,50	16,80	1	014950515
17x1,50	18,50	1	014950517
20x1,50	20,80	1	014950520
22x1,50	27,50	1	014950522

1496/C

chiavi per tappi olio motore



8 x 10 mm € 18,30 3 014960010

1497CEL

utensile per la rimozione dei connettori elettrici del gruppo VAG

permette di scollegare rapidamente i connettori senza danneggiarli



1497CEL € 18,50 1 014970170

1497D

pinza con becchi diritti per estrazione relé



A min=Max mm € 28,00 1 014970150

1497P

pinza con becchi piegati a 60° per estrazione relé



A min=Max mm € 29,00 1 014970160

1497/C23

assortimento di 23 utensili per sblocco connettori elettrici



1497/C23 € 188,00 1 014970200

440x250x70 mm - 1,7 kg

1497/C94

assortimento di 94 connettori per test su autovetture utilizzabili con i principali strumenti di diagnosi

- 2 rubacorrente
- 2 potenziometri
- 2 spie di segnalazione
- 2 connettori SRS
- 2 coccodrilli
- 2 sonde ad ago
- 2 puntali
- 2 connettori a banana doppi
- 4 connettori a banana singoli
- 24 terminali maschio piatti 0.6÷6 mm
- 12 terminali maschio tondi 1.6÷3.9 mm
- 24 terminali femmina piatti 0.6÷6 mm
- 12 terminali femmina tondi 1.6÷3.9 mm



1497/C94 € 330,00 1 014970300

430x390x100 mm - 3 kg

1497RC

coppia di rubacorrente

- sezione cavi: 1,5÷3,5 mm
- voltaggio: 0÷330V
- corrente massima 5A



1497RC € 62,50 1 014970351

1497KB/S3

kit di 3 utensili per rimozione connettori elettrici Knorr e Bremse

- 1 utensile per connettori a baionetta
- 1 utensile con impronta per connettori a 2 poli
- 1 utensile con doppia impronta per connettori a 4 o 6 poli e 12 poli



1497KB/S3 € 69,00 1 014970050

1497/S3

serie di 3 cavetti per rilevazioni segnali elettrici

- 1 pz dritto
- 1 pz 45°
- 1 pz 90°



1497/S3 € 15,50 1 014970400

1498

provatensione

CE

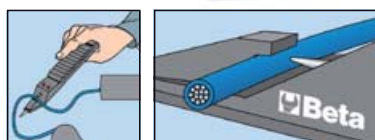

3÷48V € 41,00 2 014980100

1498MN/12

avviatore portatile multifunzione

- Avviamento di veicoli con batteria 12 Volt (diesel e benzina fino a 2000 cc.)
- Ricarica di tablet, telefoni cellulari e apparecchi elettronici in genere
- Torcia LED multifunzione



DOTAZIONE

- batteria con tecnologia Litio-Cobalto
- cavi di avviamento con pinze isolate e dispositivo di protezione contro inversione di polarità e corto circuito
- uscita USB per caricare dispositivi elettronici
- display digitale e indicatore di carica della batteria
- cavo USB con adattatori di ricarica
- alimentatore da rete e da auto

DATI TECNICI

Corrente di spunto: 600A
Tipo di batteria: LiCoO2
Uscita per avviamento: 12 Volt

1498MN/12 € 302,00 1 014980000

1498MN/12-C

cavo di avviamento con pinze per 1498MN/12



1498MN/12-C € 49,00 1 014980005

1498MN/12-R

alimentatori di rete mini avviatore 1498MN/12



1498MN/12-R € 36,50 1 014980003

1498MN/12-P

alimentatore presa auto mini avviatori 1498MN/12



1498MN/12-P € 22,00 1 014980004

 Beta

1498MN/12-U

cavi USB con adattatori universali per 1498MN



1498MN/12-U € 16,00 1 014980009

1498LT/12

avviatore portatile ultraleggero ad alte prestazioni



Il microprocessore permette la totale protezione contro:

- inversione di polarità
- corto circuito
- voltaggio errato
- sovraccarico
- sottoscarica
- sovraccarica
- sovratemperatura

DATI TECNICI

Tensione di utilizzo: 12 V
 Amperaggio continuo: 800 A
 Amperaggio massimo di avviamento: 2000 A
 Amperaggio di picco: 4000 A
 Lunghezza cavi: 500 mm
 Tipo batteria: 4 celle LifePo4
 Funzione Salva memoria: SI
 Dimensioni: 260 x 135 x 72 mm
 Peso netto: 2,5 kg
 Dotato di alimentatore di ricarica 12 V 1,3A

1498LT/12 € 705,00 1 014980012

1498LT/12-SF

staffa di fissaggio a parete per avviatore 1498LT/12



1498LT/12-SF € 117,00 1 014980013

1498LT/12-R7

alimentatore di rete per avviatore 1498LT/12



1498LT/12-R7 € 50,50 1 014980657

1498/12

avviatore per auto 12V portatile



DATI TECNICI:

- Corrente di spunto 2200A
- Tracolla per trasporto inclusa
- Batteria ermetica al piombo electrolyte solido (AGM)

1498/12 € 585,00 1 014980480

13 kg

1498/24

avviatore per auto e veicoli commerciali 12-24V portatile



DATI TECNICI:

- Corrente di spunto 4200A (12V) - 2100A (24V)
- Tracolla per trasporto inclusa
- Batteria ermetica al piombo electrolyte solido (AGM)

1498/24 € 1.180,00 1 014980490

17 kg

1498B12/R02

batteria di ricambio 12V per avviatori 12-24V



1498B12/R02 € 255,00 1 014980502

1498/12-24 R20

alimentatore di rete per avviatore 1498/12 e 1498/24



1498/12-24 R20 € 61,00 1 014980520

1498C/24

avviatore carrellato 24V



- struttura carrellata per facilitare gli spostamenti e ridurre al minimo gli sforzi
- prestazioni molto elevate per numerosi avviamenti anche particolarmente impegnativi
- caricabatterie elettronico in dotazione
- segnalazioni led e acustiche in caso di inversione di polarità
- sistema di protezione contro i picchi di tensione
- indicazione del livello di carica della batteria
- batteria ermetica al piombo electrolyte solido (AGM)

Amperaggio continuo	1700 A
Tensione utilizzo	24 V
Amperaggio di spunto	4000 A
Lunghezza cavi	2000 mm
Sezione cavi	70 mm
Tensione di ricarica	230 V
Caricabatterie automatico	24 V - 10 A

1498C/24 € 3.380,00 1 014980244



1498/2A

caricabatterie elettronico 12V per motocicli

permette la carica di tutti i tipi di batterie al Pb Wet, Agm, Gel, Mf, Vrla e delle batterie al Litio LiFePo4



- due specifici tipi di carica per batterie al Litio e al Piombo
- ciclo di ricarica multifase automatico
- protezione contro inversione di polarità e corto circuito
- grado di protezione IP65
- include cavo con pinze e cavo con occhielli
- tensione di alimentazione: 220-240V

DATI TECNICI

- corrente di ricarica: 1A
- capacità di ricarica: 2Ah-40Ah
- frequenza: 50-60 Hz
- tensione della batteria: 12V
- dimensioni: 180x80x40 mm
- peso: 0,5 Kg

1498/2A € 107,50 1 014980102

1498/4A

caricabatterie elettronico 6-12V auto-moto



- protezione di inversione polarità, corto circuito
- selezione automatica della tensione 6 o 12 Volt
- selezione automatica del tipo di batteria
- display digitale retroilluminato
- gancio di fissaggio reclinabile

DATI TECNICI

- Tensione di alimentazione: 220V-240V
- Frequenza: 50-60 Hz
- Corrente nominale (min-max): 1-4 Amp
- Tensione della batteria: 6V/12V
- Capacità batteria: 4Ah-80Ah
- Tempo di ricarica: 12 ore
- Grado di protezione: IP65

1498/4A € 131,00 1 014980104

1498SA/2A-4A

cavo con presa accendisigari per 1498/2A e 1498/4A



1498SA/2A-4A € 27,50 1 014980120

1498/8A

caricabatterie elettronico 12V auto-veicoli commerciali



- carica lenta e veloce (2A-8A)
- funzione recupero batterie scariche
- funzione alimentatore 13,8V-5A
- protezione di inversione polarità e corto circuito
- selezione manuale tipo batteria
- display digitale retroilluminato
- gancio di fissaggio reclinabile

DATI TECNICI

- Tensione di alimentazione: 220V - 240V
- Frequenza: 50-60 Hz
- Corrente nominale (min-max): 2-8 Amp
- Tensione della batteria: 12V
- Capacità batteria: 5Ah-160Ah
- Funzione Memory Saver: 13,8V - 5A
- Grado di protezione: IP65

1498/8A € 185,00 1 014980108

1498/4A-8A CO

cavo ad occhielli per 1498/2A - /4A



1498/4A-8A-CO € 13,20 1 014980114

1498/4A-8A CP

cavo con pinze per 1498/2A - /4A - /8A



1498/4A-8A-CP € 17,00 1 014980118

1498/2A-8A-PR

prolunga per 1498/2A/4A/8A



1498/2A-8A-PR € 32,00 1 014980119

1498/16A

caricabatterie elettronico 12-24V multifunzione



- display grafico retroilluminato
- corrente massima di carica 16A continui
- carica e mantenimento
- protezione contro inversione polarità, corto circuito
- 9 fasi di ricarica
- floating system
- funzione SHOW ROOM (13.8V - 12A)
- funzione SUPPLY (14V - 12A)
- funzione memory saver (13.8V - 12A)
- funzione recupero batterie
- porta pinze
- gancio di fissaggio reclinabile
- inclusi accessori: cavo con pinza, cavo con occhielli

DATI TECNICI

- Alimentazione: 220-240V
- Potenza: 240W
- Corrente di carica: 4-16A
- Tipo batterie: Agm - Wet - Lithium (LiFePo4)
- Capacità di carica: 5-360Ah
- Capacità di mantenimento: 5-550Ah
- Tensione in uscita: 12-24V
- Tensione minima batteria: 0,8V
- Grado di protezione: IP20

1498/16A € 390,00 1 014980126



1498/30A

caricabatterie elettronico
6-12-24V multifunzione

Permette la carica delle batterie
e alimenta i veicoli durante le operazioni di diagnosi



- corrente massima di carica 30A continui
- carica e mantenimento
- funzione recupero batterie- alimentazione ECU
- protezione contro inversione polarità, corto circuito, voltaggio errato e sovraccarico

DATI TECNICI

Alimentazione: 220-240V
Potenza: 500W
Corrente di carica: 5-30A
Tipo batterie: Agm - Wet - Lithium (LiFePo4)
Capacità di carica: 5-300Ah
Capacità di mantenimento: 5-900Ah
Tensione in uscita: 6-12-24V

1498/30A € 835,00 1 014980130

1498/50A

caricabatterie elettronico 12V multifunzione

Per la carica e l'alimentazione dei veicoli
durante tutte le fasi di riprogrammazione e autodiagnosi



CARATTERISTICHE

- corrente max di carica/alimentazione 50 Ampere
- carica
- funzione recupero batterie scariche
- alimentazione per protocolli diagnosi ECU
- gestione elettronica con microprocessore
- protezione contro inversione polarità e corto circuito

DATI TECNICI

Lunghezza cavi: 3m
Sezione: 10 mm²
Capacità di carica: 5÷500Ah
Capacità mantenimento: 5÷1500Ah
Tensione: 12V

1498/50A € 1.365,00 1 014980050

150x100x250 mm

1498/120A

caricabatterie elettronico
12V multifunzione

Permette la carica delle batterie
e l'alimentazione dei veicoli durante
tutte le fasi di riprogrammazione e autodiagnosi



- corrente massima di carica 120A continui
- carica e mantenimento con microprocessore CPU
- funzione recupero batterie
- riprogrammazione e alimentazione ECU
- protezione contro inversione polarità, corto circuito, voltaggio errato e sovraccarico

DATI TECNICI

Alimentazione: 90-260V
Potenza: 1500W
Corrente di carica: 10-120A
Tipo batterie: Agm - Wet - Lithium (LifePo4)
Capacità di carica: 10-1200Ah
Capacità di mantenimento: 5-3600Ah
Tensione in uscita: 12V
Lunghezza cavi con pinze: 2700 mm
Dimensioni: 310 x 150 x 350 mm
Peso: 8,5 Kg

1498/120A € 2.415,00 1 014980142

1498/40A

caricabatterie avviatore multifunzione 12-24V
carrellato

non avendo una batteria interna, la funzione di avviamento
(max 350A) non sostituisce quella di un avviatore specifico tipo
1498LT/12 (2000A)



- 3 cicli di carica programmati e 1 ciclo manuale
- potenziometro di regolazione elettronica
- processi specifici di carica WET-SPIRAL/GEL-AGM
- sistema di controllo e protezione elettronico
- processo di carica a 10 fasi
- funzione desolfatazione e recupero batteria
- funzione supply
- doppia tensione 12-24V
- idoneo anche per batterie Start&Stop
- pinze professionali in ottone isolate in gomma

DATI TECNICI

Alimentazione: 230V
Tensione in uscita: 12-24V
Corrente di carica: 1-40A
Corrente di avviamento: 350A max cc
Capacità di ricarica: 4-450Ah

1498/40A € 980,00 1 014980140

330x250x792

1498SM

salva memorie 12V

evita la perdita dei dati memorizzati dal computer di bordo delle
autovetture durante le operazioni di manutenzione o sostituzione
della batteria.



DATI TECNICI:

- autoalimentato
- batteria interna Pb 5 Ah
- 12 Volt
- connessione professionale con presa OBD

1498SM € 210,00 1 014980020

1498SM-C

cavi memorie auto OBD II 12V per 1498SM/C



1498SM-C € 23,00 1 014980021

1498SM-CP

cavi memorie auto pinza 12V 1498SM/CP



1498SM-CP € 21,00 1 014980022

1498SM-A

alimentatori salva memorie 1498SM/A



1498SM-A € 23,50 1 014980023

1498TB/12-24

tester digitale per batteria 12V
e analizzatore sistema di avviamento e ricarica
12-24V

- permette di effettuare i seguenti test: batteria, alternatore (intelligente e normale) e avviamento, ripple di diodo e prova di messa a terra
- dotato di software per stampare il test eseguito da PC
- display retroilluminato
- struttura compatta e antiurto
- software in 10 lingue
- dotato di un apposito ingresso per il collegamento di una mini stampante estraibile (accessorio opzionale Beta 1498ST/TB)



DATI TECNICI:

- applicazioni: Test batterie 12V - Test alternatore 12-24V carica - Test sistemi avviamento
- intervallo di funzionamento: 100-2000 CCA
- normative di riferimento: CCA, SAE, DIN, EN, IEC, JIS
- batterie supportate: PB, WET, GEL, AGM, AGM FLAT, EFB
- voltmetro: 9V-36V
- lunghezza cavi: 1600 mm
- lingue: Italiano, Inglese, Francese, Tedesco, Spagnolo, Polacco, Rumeno, Olandese, Svedese e Finlandese
- accessori inclusi: Cavo USB e Software

1498TB/12-24 € 557,00 1 014980401

1498ST/TB

mini stampante termica

per Tester 1498TB/12 e 1498TB/12-24

- possibilità di collegare la mini stampante direttamente sul tester
- permette di stampare i risultati del test effettuato



CE

1498ST/TB € 199,00 1 014980410

1498ST/TB ROT

ricambio carta

per stampante 1498ST/TB



1498ST/TB ROT € 9,50 2 014980411

1498PC

stabilizzatore di tensione 12-24 V

Indispensabile per proteggere le centraline
in fase di saldatura ed avviamenti con avviatori



1498PC € 83,50 1 014980801



1498TC

tester digitale per candele di
preriscaldamento

Permette un rapido e preciso test
delle candele di preriscaldamento

- adatto a tutti i tipi di candele 4,4-5-7-8,5-10-11 Volt
- display digitale retroilluminato
- adatto alle candele in acciaio e in ceramica
- protetto contro il cortocircuito e inversione di polarità
- spegnimento automatico quando inutilizzato

- dotato di segnalatore acustico
- dotato di torcia a led SMD
- struttura compatta ed antiurto



CE

DATI TECNICI:

- range di misura: 0.00÷25.0Ω
- tolleranza: ± 2%
- risoluzione: 0.01
- led Display: 1.8"
- temperatura di esercizio: 0°C÷50°C
- alimentazione: 1 batteria 9V (non inclusa)

1498TC € 169,00 1 014980450

1499

stetoscopio



1499 € 84,00 1 014990001

1500/...

estrattori universali
a due griffe

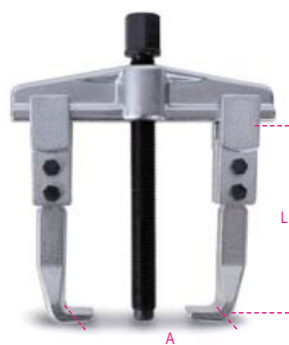

L mm	€		
1500/1	100	70,00	1 015000301
1500/2	100	73,00	1 015000302
1500/3	150	121,50	1 015000303
1500/4	150	167,00	1 015000304
1500/5	205	303,00	1 015000305
1500/6	205	355,00	1 015000306
1500/7	205	532,00	1 015000307
1500/8	230	850,00	1 015000308

A min+Max mm	A1 min+Max mm
1500/1	25÷80 70÷130
1500/2	25÷130 80÷180
1500/3	50÷160 105÷220
1500/4	60÷200 120÷270
1500/5	80÷250 160÷330
1500/6	80÷350 160÷420
1500/7	110÷520 195÷600
1500/8	170÷640 260÷715



	€		
1500/SP5	792,00	1	015000325
1500/1-1500/2-1500/3			
1500/4-1500/5			
1500/SPV	68,00	1	015000001

1500G/...

coppia di griffe tipo normale
per 1500 e 1580/81



mm	1500	€		
1500G/1	35 /1-2	45,50	1	015000311
1500G/3	35 /3-4	66,50	1	015000313
1500G/5	35 /5-6-7	135,00	1	015000315
1500G/8	50 /8	165,50	1	015000317

1580/81

1500N/...

estrattori universali
a 2 griffe scorrevoli

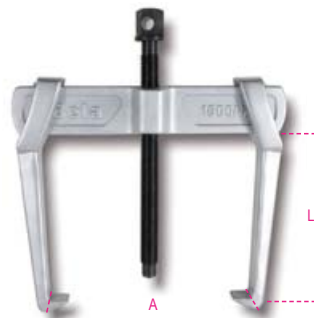

A min+Max mm	L mm	€		
1500N/0	18÷65 70	62,50	1	015000600
1500N/1	23÷70 100	65,50	1	015000601
1500N/2	23÷100 100	71,00	1	015000602
1500N/3	35÷140 150	117,50	1	015000603
1500N/4	35÷190 150	126,50	1	015000604
1500N/5	43÷250 205	243,00	1	015000605
1500N/6	43÷320 205	263,00	1	015000606



	€		
1500N/SP6	686,00	1	015000626
1500N/0-1500N/1-1500N/2-1500N/3			
1500N/4-1500N/5			
1500N/SPV	83,00	1	015000006

1500N/G...

griffe per estrattori 1500N



mm	1500N	€		
1500N/G0	10 /0	20,70	2	015000650
1500N/G1-2	12 /1-2	22,30	2	015000651
1500N/G3-4	17 /3-4	39,00	2	015000653
1500N/G5-6	23 /5-6	75,50	2	015000655



1501/1-2-3

estrattori a griffe sottili



L mm	€		
1501/1	100	157,00	1 015010101
1501/2	200	167,00	1 015010102
1501/3	250	175,00	1 015010103

A min+Max mm	
1501/1	25÷130
1501/2	25÷130
1501/3	25÷130

1501G/1-2-3

coppie di griffe per 1501



L mm	€		
1501G/1	100	87,00	1 015010111
1501G/2	200	101,00	1 015010112
1501G/3	250	110,00	1 015010113

1501Z/S-P-R

terminali per griffe 1501G



mm	D mm	€		
1501Z/S	2,0 27	31,50	2	015010211
1501Z/P	3,6 27	32,00	2	015010212
1501Z/R	3,6 14	35,50	2	015010213

1505V

estrattore per bracci tergitristalli e tergilunotti

puntale in ottone forato removibile per estrazione bracci con ugello lavavetro integrato



1505V	A Max mm	L mm	€	1	015050001
	43	37	36,50		

1505/C5

kit per estrazione tergitristalli

1 estrattore a 2 griffe Ø 25+40 mm
4 mezzalune Ø 25 mm, Ø 30 mm, Ø 35 mm, Ø 41 mm



1505/C5	€	1	015050300
	122,00		

320x150x60 mm - 1,2 kg

1506

estrattore autoserrante a due griffe

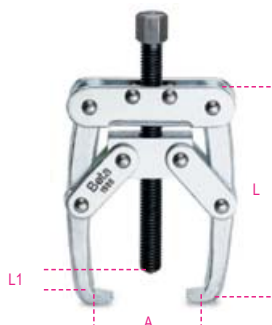

1506	A min+Max mm	L mm	L1 mm	€	1	015060001
	10+50	80	40	38,00		

1508/1 - 1508/2

estrattori a due griffe tipo leggero

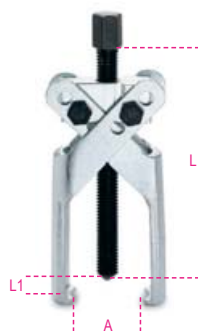

1508/1	L mm	€	1	015080001
	105	125,00		
1508/2	L mm	€	1	015080002
	130	149,00		

1508/1	A min+Max mm	L1 mm
	6+100	105
1508/2	A min+Max mm	L1 mm
	10+140	130

1511/1 - 2 - 3

estrattori a due griffe reversibili per esterni

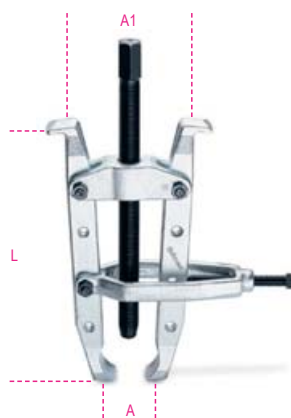

1511/1	L mm	€	1	015110001
	235	212,00		
1511/2	L mm	€	1	015110002
	330	265,00		
1511/3	L mm	€	1	015110003
	405	329,00		

1511/1	A min+Max mm	A1 min+Max mm
	20+100	65+95
1511/2	A min+Max mm	A1 min+Max mm
	40+150	103+190
1511/3	A min+Max mm	A1 min+Max mm
	40+150	103+175

1515/1 - 2 - 3

estrattori a due griffe oscillanti

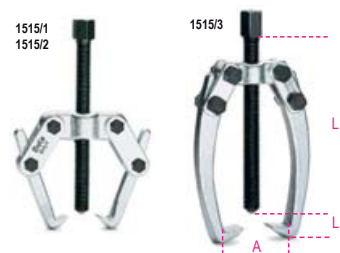

1515/1	L mm	€	1	015150101
	85	28,00		
1515/2	L mm	€	1	015150102
	85	30,00		
1515/3	L mm	€	1	015150103
	105	44,50		

1515/1	A Max mm	L1 mm
	60	105
1515/2	A Max mm	L1 mm
	70	105
1515/3	A Max mm	L1 mm
	90	105

1516/1 - 2 - 3

estrattori a tre griffe oscillanti



1516/1	L mm	€	1	015160001
	85	40,00		
1516/2	L mm	€	1	015160002
	85	43,00		
1516/3	L mm	€	1	015160003
	105	61,00		

1516/1	A Max mm	L1 mm
	60	85
1516/2	A Max mm	L1 mm
	70	85
1516/3	A Max mm	L1 mm
	90	105

1517

estrattori 3 griffe autoserranti

- per elevati carichi d' estrazione.
- effetto autoserrante.



1517/90	L mm	L1 mm	Ø mm	€	1	015170000
	182	60	22	218,00		
1517/150	L mm	L1 mm	Ø mm	€	1	015170010
	242	115	22	223,00		
1517/200	L mm	L1 mm	Ø mm	€	1	015170020
	307	150	22	257,00		
1517/260	L mm	L1 mm	Ø mm	€	1	015170030
	395	180	30	299,00		

1517/90	Ø mm	A mm	kg	N
	19	18+90	6000	59000
1517/150	Ø mm	A mm	kg	N
	19	25+150	6000	59000
1517/200	Ø mm	A mm	kg	N
	19	40+200	6000	59000
1517/260	Ø mm	A mm	kg	N
	27	50+260	8000	78500

Beta

1518/...

estrattori a tre griffe



	L mm	€		
1518/1	105	67,50	1	015180001
1518/2	135	86,50	1	015180002
1518/3	235	153,00	1	015180003
1518/4	270	227,00	1	015180004
1518/5	270	267,00	1	015180005
1518/6	270	279,00	1	015180006

	A min+Max mm	L1 mm
1518/1	24÷100	105
1518/2	32÷160	150
1518/3	40÷220	220
1518/4	80÷250	240
1518/5	80÷300	350
1518/6	80÷350	400

1520/1 - 1520/2

estrattori a due griffe reversibili



	L mm	€		
1520/1	135	64,00	1	015200101
1520/2	235	110,00	1	015200102

	A Max mm	L1 mm
1520/1	110	85
1520/2	160	140

1521/1 - 1521/2

estrattori a tre griffe reversibili



	L mm	€		
1521/1	135	83,00	1	015210101
1521/2	235	146,00	1	015210102

	A Max mm	L1 mm
1521/1	110	90
1521/2	160	140

1528

estrattore autoserrante per dischi freno



	A min+Max mm	€		
170÷380	170÷380	147,00	1	015280000

480x240x60 mm - 4,8 kg

1529

estrattore per pulegge multigola

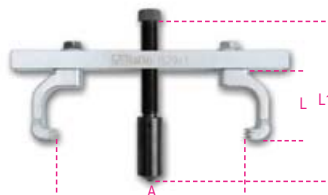

	A min+Max mm	L min+Max mm	L1 min+Max mm	€		
24÷240	60÷95	90÷135	215,00	1	015290000	

260x210x60 mm - 2,6 kg

1529/C7

estrattore per pulegge

Incluse nel kit:

- 2 griffe con doppio piede spesso 4,7 mm
- 2 griffe a singolo piede spesso 4,3 mm
- 1 griffa con doppio piede spesso 2,3 mm
- 1 griffa a singolo piede spesso 2,3 mm

La coppia di griffe è componibile in base all'esigenza operativa



	L mm	L1 mm	A min+Max mm	€		
1529/C7	50	72,5	53÷114	126,00	1	015290100

285x155x50 mm - 2 kg

1529PI

estrattore universale per puleggia pompa iniezione

- permette un rapido e preciso smontaggio della puleggia pompa iniezione carburante.
- particolarmente indicato per Fiat, Ford, Volkswagen, Citroen e Peugeot

Incluse 3 coppie di viti per serrare l'estrattore alla puleggia:
 M6 x 1.0 x 49 mm
 M7 x 1.0 x 75 mm
 M8 x 1.25 x 76 mm



	€		
1529PI	90,00	1	015290051

1529/PG

estrattore per pompa alta pressione gasolio vetture gruppo VAG



	€		
15-24	55,50	1	015290010

1530/C5

kit per estrazione mozzi e cuscinetti ruote a 3, 4, 5 fori

Il kit comprende:

- 1 flangia universale 96÷138 mm
- 1 vite idraulica da 12 tonnellate
- 1 massa battente da 2,8 kg indispensabile per mozzetti senza bullone di fissaggio centrale



	€		
1530/C5	455,00	1	015300300

760x320x120 mm - 11,5 kg



1530/C16

kit a massa battente con colonnette distanziatrici, per estrazione mozzi e cuscinetti ruote a 3, 4, 5 fori

Ideale per mozzi con anello di centraggio sporgente

il kit comprende:

- 1 flangia universale 90÷130 mm
- 1 massa battente da 5 kg
- 4 colonnette attacco M12
- 4 colonnette attacco M14



1530/C16	€ 559,00	1	015300316
≡ 760x310x100 mm - 13,5 kg			

1532

utensile per rimozione guarnizioni e paraoli



1532	€ 14,20	2	015320001
------	---------	---	-----------

1533/...

tiranti per separatori 1534

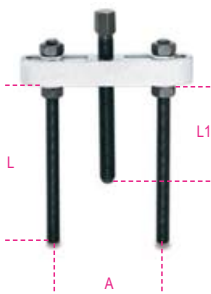

L mm	€		
1533/2 150	93,00	1	015330002
1533/3 210	177,00	1	015330003
1533/4 315	280,00	1	015330004
1533/5A 305	339,00	1	015330006

A min=Max mm	L1 mm
1533/2 45÷140	110
1533/3 55÷205	175
1533/4 90÷260	175
1533/5A 100÷360	235

1533PR/1-2-3

prolunghe per tiranti 1533



1533PR/1 1533/2	€ 20,30	1	015330011
1533PR/2 1533/3	21,80	1	015330012
1533PR/3 1533/4-5	23,00	1	015330013
1533PR/5A 1533/5A	23,00	1	015330016

1534/...

separatori

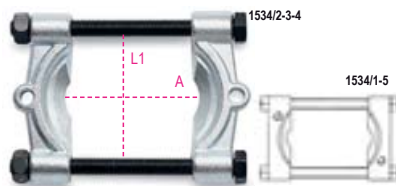

		€		
1534/1	1533/2	81,00	1	015340001
1534/2	1533/2	96,00	1	015340002
1534/3	1533/3	159,00	1	015340003
1534/4	1533/4	267,00	1	015340004
1534/5A	1533/5A	550,00	1	015340006

	A min=Max mm	L1 mm
1534/1	5÷60	63
1534/2	12÷75	75
1534/3	22÷115	118
1534/4	25÷155	154
1534/5A	30÷220	180

1535/C...

estrattori combinati



1535/C1	€ 267,00	1	015350001
---------	----------	---	-----------



≡ 260x180x40 mm - 2,5 kg

1535/C2	€ 282,00	1	015350002
---------	----------	---	-----------



≡ 260x180x40 mm - 2,8 kg

1535/C3	€ 455,00	1	015350003
---------	----------	---	-----------



≡ 380x280x55 mm - 8,0 kg

1535/C4	€ 703,00	1	015350004
---------	----------	---	-----------



≡ 420x380x65 mm - 14,8 kg

1535/C5A	€ 1.071,00	1	015350006
----------	------------	---	-----------



≡ 530x510x85 mm - 27,2 kg

1539

tiramiere a percussione



1539	€ 141,50	1	015390001
------	----------	---	-----------

1540

estrattore a percussione

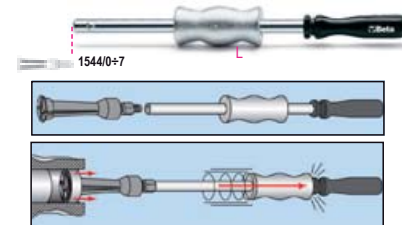

1540	L mm 390	€ 79,50	1	015400001
	M10	1544	0÷7	

Beta

1542/1 - 1542/2

estrattori per griffe ed espansori



	A	1544	€		
1542/1	35÷75	0÷7	68,00	1	015420001
1542/2	60÷130	9C-10C	102,50	1	015420002

	L	L1
1542/1	140	140
1542/2	175	160

1544/...

espansori a settori per interni

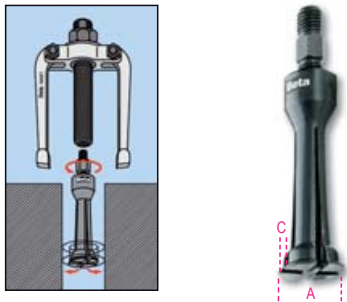

	C	M	€		
1544/0	0,25	M10	60,50	1	015440100
A= 5÷7					
1544/A	0,80	M10	62,50	1	015440105
A= 7÷9					
1544/1	0,80	M10	64,00	1	015440110
A= 9÷12					
1544/2	1,15	M10	66,00	1	015440120
A= 13÷17					
1544/2B	1,00	M10	67,00	1	015440121
A= 14÷19					
1544/3	1,70	M10	69,00	1	015440130
A= 16÷21					
1544/4	1,65	M10	76,00	1	015440140
A= 20÷25					
1544/5	2,00	M10	82,00	1	015440150
A= 25÷30					
1544/6	3,00	M10	102,50	1	015440160
A= 30÷37					
1544/7	3,80	M10	116,50	1	015440170
A= 38÷45					
1544/9C	2,60	G 3/8"	169,00	1	015440189
A= 40÷75					
1544/10C	7,30	G 3/8"	233,00	1	015440199
A= 70÷115					

1545/C5M

estrattore 1542/1 con 5 espansori 1544



	€		
1545/C5M	455,00	1	015450011

1542/1	● 24 mm
1544/1	9÷12 mm
1544/2	13÷17 mm
1544/3	16÷21 mm
1544/4	20÷25 mm
1544/5	25÷30 mm

265x180x45 mm - 2,4 kg

1547/C6

estrattori per cuscinetti con false sfere

Cuscinetti:

1547/1
6011-6014, 6206-6211, 6303-6308, 6403-6405
1547/2
6004-6010, 6200-6205, 6300-6304

• utilizzabile solo dopo aver "sgabbiato" le sfere.



	€		
1547/C6	235,00	1	015470006

420x185x60 mm - 3 kg

1547KP

set di 3 coppie di terminali a falsa sfera



	∅	€		
1547KP/1	9-11-12,5	37,50	1	015470106
1547KP/2	5-6-8	24,50	1	015470206

1547P

prolunghe esagonali



	L	∅	€		
1547P/1	205	1547/1	8,00	1	015470101
1547P/2	102	1547/2	5,10	1	015470201

1547PC/2

prolunghe tonde corte



	L	∅	€		
1547PC/2	42	1547/2	4,10	1	015470202

1547PL/2

prolunghe tonde lunghe



	L	∅	€		
1547PL/2	106	1547/2	4,60	1	015470203

1549

kit per smontaggio e montaggio ammortizzatori a doppio effetto con rientro a gas

permette di mantenere lo stelo in estensione durante il montaggio delle molle



	€		
1549	325,00	1	015490001

310x270x110 mm - 3 kg



1550U

smonta ammortizzatori pneumatico per autoveicoli, SUV e veicoli commerciali

CE

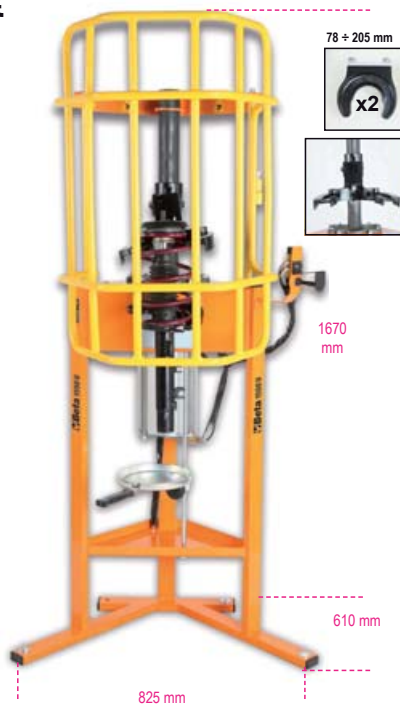

MAGGIOR POTENZA: potenza spinta massima 2 ton (10 bar)
SISTEMA UNIVERSALE DI PRESA SUPERIORE: consente con una unica piastra adattabile superiore di comprimere tutti i diametri di molla sia destrorse che sinistrorse
SISTEMA DI SICUREZZA ATTIVA SULLA MOLLA: attraverso il gancio di sicurezza e le 3 valvole di blocco è garantito il corretto posizionamento/alloggiamento della molla mantenendo tale posizione per tutta l'operazione di compressione. In caso di posizionamento "non conforme" della molla il sistema ferma la macchina.
GRIGLIA DI PROTEZIONE "FULL BODY": garantisce la massima sicurezza e copertura della zona di lavoro
AZIONAMENTO CON LEVA DI COMANDO: maggior precisione e sensibilità durante la fase di compressione
POSIZIONE DI LAVORO: altezza di lavoro sulla staffa posteriore alzata fino a 875 mm

Fornito di 2 staffe inferiori per diametri 78-205 mm

DATI TECNICI

Potenza spinta: 2 ton (10 bar) - 1.6 ton (8 bar) - 1.2 ton (6 bar)
 Corsa di compressione molla: 335 mm

1550U € 2.480,00 1 015500010

1550U/CGS-R

coppia ganasce superiori ribassate per 1550U



1550U CGS-R € 475,00 1 015500035

1550U/MRC-ABE

staffe speciali per 1550U
 specifiche per Mercedes Classe A-B-E



1550U/MRC-ABE € 490,00 1 015500031

1550U/MRC-C

staffe speciali per 1550U
 specifiche per Mercedes Classe C



1550U/MRC-C € 430,00 1 015500032

1550U/S...

staffa inferiore per 1550U



	Ø mm	€		
1550U/S 130	78+130 mm	310,00	1	015500014
1550U/S 182	105+182 mm	310,00	1	015500015
1550U/S 205	125+205 mm	310,00	1	015500016

1550U/SS187

staffa sinistrorsa per 1550U

particolarmente indicata per molle con profilo sinistro tipo Nissan Qashqai e Renault Koleos



1550U/SS 187 € 310,00 1 015500018

1550U/M

morsa per smonta ammortizzatori 1550U

permette il bloccaggio dello stelo dell'ammortizzatore



1550U/M € 295,00 1 015500021

1551/C20

kit per smontaggio teste ammortizzatori

inclusi nel kit:

- 7 bussole esagonali misure: 16 - 17 - 18 - 19 - 21 - 22 - 24
- 1 prolunga porta bussola lunga 120 mm
- 3 inserti femmina con cava misure: 8x5 - 8x6 - 11x8
- 1 inserto femmina esagonale misura: 10 mm
- 1 inserto maschio XZN® misura: M10
- 1 inserto maschio Torx® misura: T50
- 4 inserti maschio esagonali misure: 5 - 6 - 7 - 8
- 1 prolunga porta inserti lunga 95 mm
- 1 prolunga porta inserti lunga 190 mm



○ 8 - 21 mm

1551/C20 € 130,00 1 015510020

320x245x71 mm - 2,6 kg

1552/C9

kit per divaricare i giunti di ammortizzatori, bracci oscillanti e sterzo

è possibile lavorare con testa a singolo o doppio divaricatore, in modo da poter operare anche sui giunti doppi tipo gruppo VAG



○ 13 mm

1552/C9 € 103,00 1 015520020

195x140x40 mm - 1,0 kg



1555/Q

pressore per molle ammortizzatori MacPherson ed equivalenti

spinta massima 1800 Kg

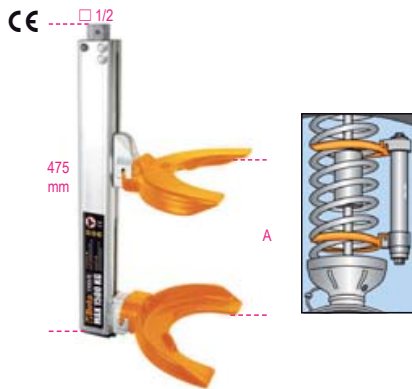

A	∅	€		
min+Max mm	min+Max mm			
65÷354	80÷195	675,00	1	015550006

1555/QS

pressore per molle ammortizzatori Mac Pherson ed equivalenti
Dotato di protezioni in plastica per l'utilizzo in morsa

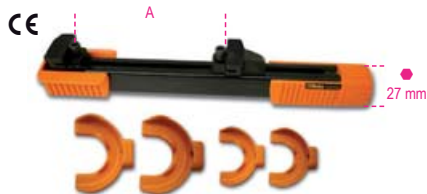

A	∅	€		
min+Max mm	min+Max mm			
70÷300	80÷200	830,00	1	015550005

1555S/BMW-RNT

staffa per ammortizzatori BMW E39, E46 e Renault Megane II per 1555Q e 1555/QS



1555S/BMW-RNT	€			
	260,00	1	015550303	

1555C

pressore telescopico per molle ammortizzatori con 4 staffe e barra di torsione



A	∅	N	t	€		
min+Max mm	min+Max mm					
80÷225	90÷160	25000	8,5	800,00	1	015550202

1556/1A

coppia di pressori per molle ammortizzatori

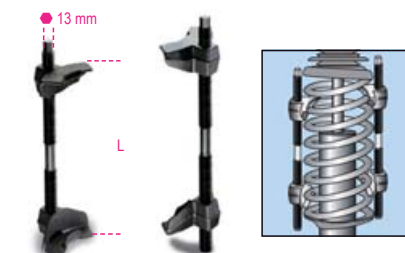

min L Max mm	€			
65÷320	195,00	1	015560101	

1556/2A

coppia di pressori per molle ammortizzatori

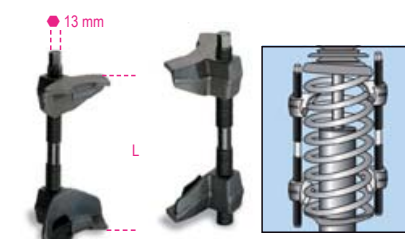

min L Max mm	€			
65÷200	192,00	1	015560102	

1557

chiavi a bussola Macchina per perni balestre Truck



L mm	L1 mm	€		
37	28	72,50	1	015570137
46	34	74,00	1	015570146
56	34	80,00	1	015570156

1557V

chiave a bussola Macchina per perni balestre Truck Volvo



mm	€			
27	38,00	1	015570299	

1557/S3

serie di 3 chiavi per ghiera ammortizzatori

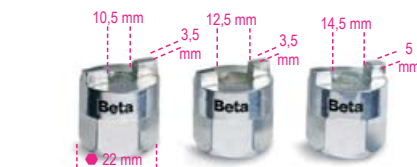

1557/S3	€			
	56,50	1	015570010	

1558/C4

attrezzo per anelli seeger interni ed esterni con azionamento a vite

grazie all'attacco quadro si applica una forza elevata in entrambe le condizioni d'utilizzo
Puntali in dotazione:
∅ 2,5-3-3,5 mm



1558/C4	∅ mm	∅ mm	€			
	5,5 ÷ 77	5,5 ÷ 77	138,00	1	015580100	

330x220x50 mm - 900 g

1558P

coppia puntali anelli seeger per 1558



∅ mm	€			
2,5	6,00	1	015580125	
3,0	6,00	1	015580130	
3,5	6,00	1	015580135	

1558/C13

attrezzo per anelli seeger interni ed esterni con azionamento a vite

grazie all'attacco quadro si applica una forza elevata in entrambe le condizioni d'utilizzo

Puntali in dotazione:
• diritti: ∅ 2,5 - 3 - 3,5 - 3,8 mm
• 45°: ∅ 2,5 - 3 - 3,5 - 3,8 mm
• 90°: ∅ 2,5 - 3 - 3,5 - 3,8 mm

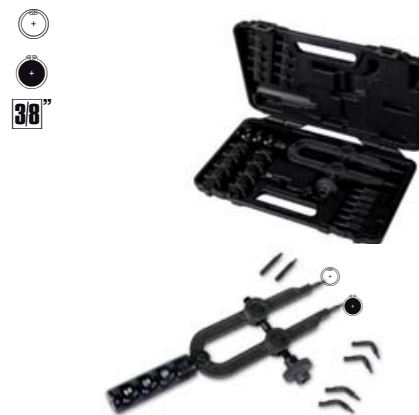

1558/C13	∅ mm	∅ mm	€			
	5,5÷77	5,5÷77	184,00	1	015580200	

330x220x45 mm - 1,6 kg

1559

estrattori per snodi sferici



	A Max mm	Ø mm	€		
1559/22	50	18÷22	72,00	1	015590001
1559/36	90	36	330,00	1	015590036
1559/45	115	45	495,00	1	015590045

1559V/8T

vite idraulica per estrattore snodi sferici
1559/36 e 1559/45



Nm	t	€		
80000	8	249,00	1	015590145

1560/1 - 1560/2

estrattori per snodi sferici
modello professionale



	A min+Max mm	Ø mm	€		
1560/1	12÷50	20	122,00	1	015600001
1560/2	60÷85	20	154,00	1	015600002

1560A

estrattore per snodi sferici



	€		
1560A	206,00	1	015600601

1561/...

estrattori per snodi sferici



	L mm	A mm	Ø mm	€		
1561/1	39	36,6	18	56,00	1	015610001
1561/2	47	45,7	25	73,00	1	015610002
1561/3	63	62	30	106,00	1	015610003
1561/4	75	63	40	135,00	1	015610004

1562D

estrattore per snodi sferici

Fornito con 2 viti per l'estrazione di giunti sospensione e sterzo



A max mm	Ø mm	● mm	L mm	€		
50	39	26	155	280,00	1	015620239

1565/1 - 2 - 3

estrattori a percussione
per snodi sferici



	Ø mm	L1 mm	€		
1565/1	18	65	63,50	1	015650001
1565/2	23	65	72,00	1	015650002
1565/3	30	88	75,00	1	015650003

1566N

attrezzo per smontaggio/montaggio
braccetti sterzo



Ø x L mm	○ mm	□ mm	€		
28÷35 x 400	27	12''	102,00	1	015660005
35÷45 x 190	27	-	102,00	1	015660008
35÷45 x 400	27	12''	114,00	1	015660010

1566/G01

estrattore per giunti omocineticici

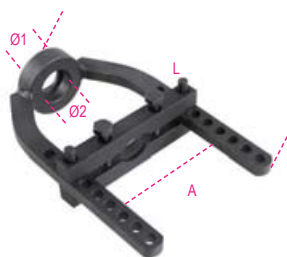

L mm	A mm	Ø1 mm	Ø2 mm	€		
250	115	29	36	121,00	1	015660052

1566P

pinza per anelli elastici
millerighe semiassi

la pinza comprime l'anello elastico semplificando
l'inserimento del semiassie nel giunto omocineticico



L mm	A Max mm	€		
280	36	55,00	1	015660091

1567

leva per estrazione testine braccio oscillante
e ammortizzatori dal montante

Utilizzabile da un solo operatore



A mm	B min+Max mm	€		
1060	100÷300	277,00	1	015670001

1569/A

assortimento di utensili per l'estrazione e
l'introduzione di: silent block ponte posteriore,
paraoli albero motore e cuscinetti ruota

- le boccole possono essere utilizzate sia direttamente sul veicolo che alla pressa idraulica
- il kit comprende:
4 barre filettate: M10-M12-M14-M16
4 rondelle
boccole per diametri da 44 a 82 mm



	€		
1569/A	850,00	1	015690011

530x415x115 mm

1569/B

assortimento utensili per l'estrazione e
l'introduzione di silent block,
paraoli e cuscinetti ruota

diametri da 14 a 32 mm



	€		
1569/B	665,00	1	015690015

1569/F

assortimento di utensili per l'estrazione e l'introduzione dei silent block di Fiat Panda, Panda 4x4, Panda Metano e Cross, Fiat 500, Ford Ka e Opel Adam



1569/F	€ 365,00	1	015690021
--------	----------	---	-----------

1569CP

insertori a percussione per cuscinetti conici e paraoli

regolazione rapida



	∅ min+Max mm	L mm	€		
1569CP/50	9,5÷50	130	109,00	1	015690750
1569CP/90	18÷90	145	135,00	1	015690790

1570/3

martinetto idraulico per estrattori



t	L mm	L1 mm	∅ mm	€	
30	243	36	19	199,00	1 015700003

1580/8I

estrattore universale idraulico a due griffe

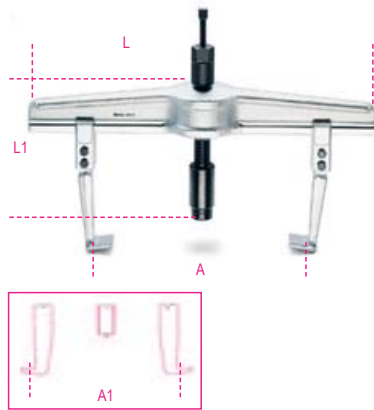

1580/8I	€ 1.285,00	1	015800008
---------	------------	---	-----------

	A min+Max mm	L mm	L1 mm	A1 min+Max mm	N Max
1580/8I	170÷640	715	280	260÷715	180000

1580GL

griffe tipo lungo per estrattori 1580/8I - 1500/8



	L mm	€	
1580GL/8A	300	145,00	1 015800227
1580GL/8B	400	161,00	1 015800228
1580GL/8C	500	205,00	1 015800229

1585/5I - 6I - 7I

estrattori a tre griffe per azionamento idraulico

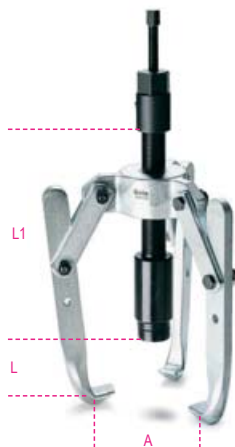

1585/5I	€ 890,00	1	015850005
1585/6I	€ 935,00	1	015850006
1585/7I	€ 960,00	1	015850007

	A min+Max mm	L1 mm	L mm	N Max
1585/5I	50÷350	135	280	150000
1585/6I	50÷350	235	280	150000
1585/7I	50÷350	335	280	150000

1585GI/5 - 6 - 7

griffe per estrattori idraulici 1585/5I - 1585/6I - 1585/7I

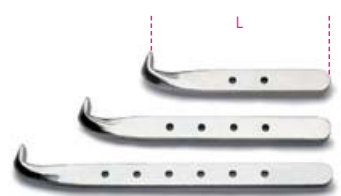

	L mm	€	
1585GI/5	135	81,00	1 015850205
1585GI/6	235	96,00	1 015850206
1585GI/7	335	116,00	1 015850207

1589VI

vite idraulica per estrattori 1580/8I e 1585/5I - 1585/6I - 1585/7I

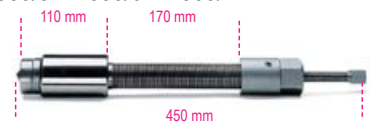

1589VI	€ 525,00	1	015890001
--------	----------	---	-----------

1589PI/50 - 100 - 150

prolunghe per vite idraulica



	L mm	L1 mm	€	
1589PI/50	50	70	47,50	1 015890005
1589PI/100	100	120	52,50	1 015890010
1589PI/150	150	170	57,50	1 015890015

1590

morsetti standard



A max mm	L1 mm	€	
60	55	21,80	2 015900305
80	65	28,50	2 015900307
100	65	35,00	2 015900310
120	85	40,00	2 015900312
150	95	58,50	2 015900315

1591

strettoi a vite



A ~	A max mm	L1 mm	€	
200	200	80	23,00	2 015910020
300	310	85	29,00	2 015910030
400	410	85	30,50	2 015910040
500	500	95	41,00	2 015910050
600	600	95	42,00	2 015910060
800	800	95	50,50	2 015910080
1000	1000	110	63,50	2 015910100

Beta

1593

serragianti a vite

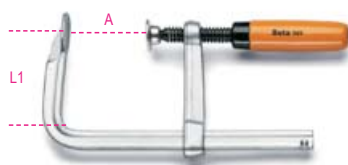

A	A max	L1	€		
~	mm	mm			
160	170	80	28,00	2	015930016
200	240	100	42,00	2	015930020
300	320	145	59,00	2	015930030

1594

serragianti a leva



A	A max	L1	€		
~	mm	mm			
200	240	145	91,00	1	015940020
250	290	145	95,00	1	015940025
300	340	145	102,00	1	015940030
400	430	150	106,00	1	015940040
500	530	150	112,00	1	015940050
600	630	150	117,00	1	015940060

1595

serragianti a vite

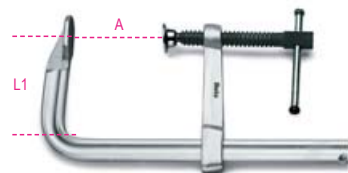

A	A max	L1	€		
~	mm	mm			
200	230	100	44,00	2	015950020
250	270	120	47,50	2	015950025
300	330	120	60,50	2	015950030
400	420	120	68,00	2	015950040
500	520	125	73,50	2	015950050
600	620	125	78,00	2	015950060
800	820	125	92,50	1	015950080
1000	1030	125	102,50	1	015950100

1599F

morse parallele da banco forgiate

con piano e guide temprate



L1	BxH	Ø	A MAX	€		
mm	mm	mm	mm			
100	92x46	11	125	274,00	1	015990100
125	108x54	13	150	348,00	1	015990125
150	125x62	13	200	490,00	1	015990150
175	140x70	15	220	667,00	1	015990175

1599P

morse parallele da banco forgiate

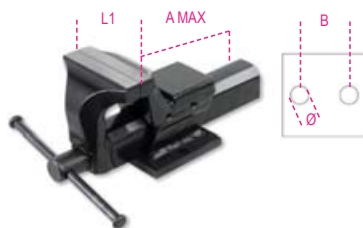

L1	B	Ø	A MAX	€		
mm	mm	mm	mm			
100	92	11	111	240,00	1	015990000
125	108	13	130	287,00	1	015990025
150	130	15	170	401,00	1	015990050

1599B

base girevoli per morsa 1599P



	1599P	€		
• 1599B 100	100	100,00	1	015990810
• 1599B 125	125	113,50	1	015990812
• 1599B 150	150	141,00	1	015990815

• base rotonda

1599T

morse parallele da trapano

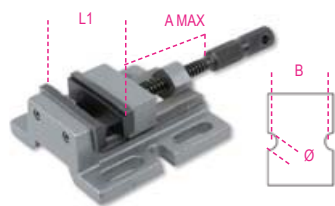

L1	B	Ø	A MAX	€		
mm	mm	mm	mm			
80	111	11	65	135,50	1	015990480
100	120	13	87	168,00	1	015990500

1599G

coppie di copriganasce in alluminio



A	€		
mm			
100	44,50	1	015990910
125	46,50	1	015990912
150	49,50	1	015990915
180	55,50	1	015990917

1600Q 8

chiave a croce per quadristi

quadro da 5 / 6 / 7-8 mm
triangolo da 9 mm
alette 3-5 mm
esagono 1/4"
inserto doppio con intaglio 1,0x7 mm e impronta a croce PH2

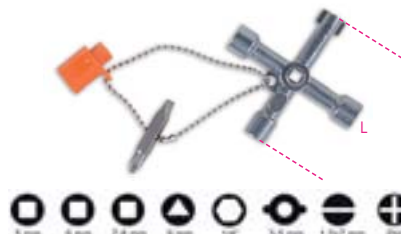

L	€		
mm			
76	24,00	1	016000008

1600Q 10

chiave snodabile a doppia croce per quadristi

quadro da 5 / 6-7 / 8-9 mm
triangolo da 5-6 / 6-7 / 8-9 mm
alette 3-5 mm
esagono 1/4"
quadro maschio 1/4"



L	€		
mm			
125	31,00	1	016000010

1601/PC

pinza a cricchetto per capicorda
telefonia e trasmissione dati



RJ11-RJ12-RJ45	€		
	52,50	2	016010011

1602

pinza per capicorda
preisolati modello leggero

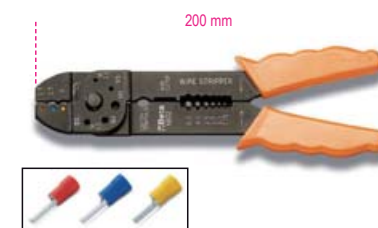

mm²	€		
0,75+6	13,00	5	016020001

1602/C9

pinza per capicorda 1602
con assortimento di 450 capicorda



1602/C9 € 107,50 1 016020045

1602	n.
BM00180 R/6,3	50
BM00280 B/6,3	50
BM00380 G/6,3	50
BM00191 R/6,3	50
BM00291 B/6,3	50
BM00392 G/6,3	50
BM00160 R/1,6	50
BM00260 B/2,3	50
BM00360 G/3,6	50

420x350x35 mm - 1,5 kg

1602A

pinza per capicorda preisolati
modello standard

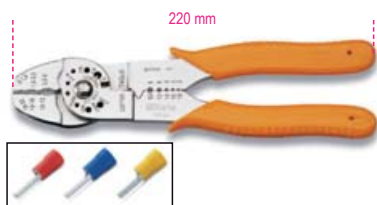

mm² € 47,50 2 016020005
0÷6

1603

pinza per capicorda
non isolati modello leggero

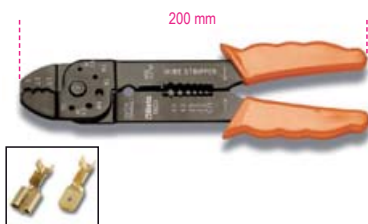

mm² € 13,00 5 016030001
1,25÷5,5



1603A

pinza per capicorda non isolati chiusi
modello standard

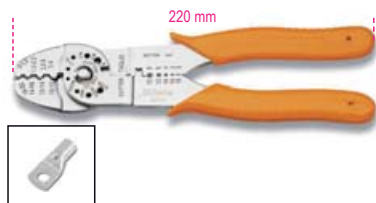

mm² € 47,50 2 016030005
0÷8

1603B

pinza per capicorda non isolati aperti
modello standard

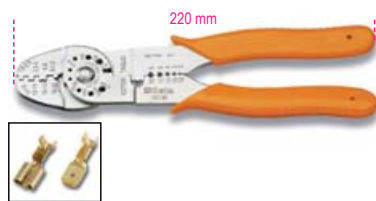

mm² € 48,50 2 016030010
0÷8

1606/2

pinza a grande effetto
per capicorda a tubetto



mm² L A B € 285,00 1 016060002
0,14÷10 175 65 20

1606A

pinza per capicorda a tubetto



mm² € 76,00 1 016060010
1606A16 6÷16 € 76,00 1 016060016

1606A/C9

Pinza per capicorda a tubetto 1606A6
con assortimento di 450 capicorda



1606A/C9 € 127,50 1 016060045

1606A6	n.
BM00601 W/0,5	50
BM00604 N/1,5	100
BM00506 B/2,5	100
BM00508 G/4	100
BM00610 Y/6	100

420x350x35 mm - 2,5 kg

1606T

pinza per capicorda a tubetto,
crimpatura su 4 lati

minore sforzo alla leva



mm² L A B € 255,00 1 016060005
0,1÷10 173 61 13

1607

pinza a grande effetto per connettori BNC
per cavi coassiali RG 58, RG 59, RG 62,
RG 71



mm L A B € 250,00 1 016070001
1607 220 73 19

1608

pinza per capicorda preisolati,
con regolatore di pressione



mm²
0,5÷6 € 98,00 1 016080001

1608/C9

pinza per capicorda 1608
con assortimento di 450 capicorda



1608/C9 € 192,50 1 016080045

1608		n.
BM00180	R/6,3	1
BM00280	B/6,3	50
BM00380	G/6,3	50
BM00191	R/6,3	50
BM00291	B/6,3	50
BM00392	G/6,3	50
BM00160	R/1,6	50
BM00260	B/2,3	50
BM00360	G/3,6	50

420x350x35 mm - 2 kg

1608A

pinza a grande effetto
per capicorda preisolati



mm²
0,75÷6 € 198,00 1 016080005

1609

pinza per capicorda non isolati



mm²
0,5÷2,5 € 98,00 1 016090001

1609A

pinza a grande effetto
per capicorda non isolati



mm²
0,5÷6 € 385,00 1 016090005

1609B

pinza per capicorda non isolati



L
mm mm²
600 10÷120 € 260,00 1 016090101

1609C/C5

pinza oleodinamica per capicorda

crimpature esagonali



mm²
50÷240 € 1.670,00 1 016090210

500x300x110 mm - 4 kg

1609M

coppia di matrici per 1609C

crimpature esagonali



1609M/16	mm ² 10-16	€ 59,50	1	016090221
1609M/35	25-35	59,50	1	016090223
1609M/70	50-70	59,50	1	016090225
1609M/120	95-120	59,50	1	016090227
1609M/150	150	59,50	1	016090229
1609M/185	185	59,50	1	016090231
1609M/240	240	59,50	1	016090233

1639S

sonda tirafili in nylon

con teste intercambiabili



L m Ø mm
10 4 € 17,20 1 016390010

1640K

foralamiera oleodinamica con 4 fustelle

forature tonde

22,5-25,5-32,5-55,5 mm



1640K € 1.455,00 1 016400001

470x400x100 mm

1640

punzonatrice per lamiera



1640 € 940,00 1 016400100



1640A

adattatore per 1640



1640A	€ 10,50	1	016400080
-------	---------	---	-----------

1640P

perno filettato per 1640



	Ø mm	€		
1640P/9	9,5	31,50	1	016400088
1640P/19	19	36,00	1	016400089

1640Q

fustelle quadre per 1640 con perno incluso



1640Q 45	mm 45x45	€ 625,00	1	016400065
----------	----------	----------	---	-----------

1640T

fustelle tonde per 1640

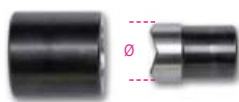

	Ø mm	€		
1640T 22,5	22,5	60,00	1	016400022
1640T 25,5	25,5	78,00	1	016400025
1640T 32,5	32,5	94,00	1	016400032
1640T 55,5	55,5	120,00	1	016400055

1650

calibro a corsoio lettura ventesimale



UNI EN ISO 13385-1DIN 862

A max mm	L mm	€		
150	235	52,00	1	016500001
200	290	68,50	1	016500002

1650FD

calibro a corsoio per dischi freni lettura decimale

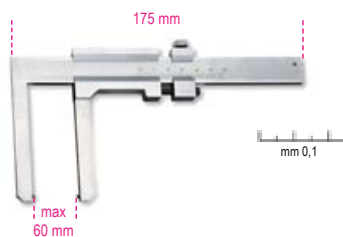

1650FD	€ 179,00	1	016500050
--------	----------	---	-----------

1650FT

calibro a corsoio per tamburi freni lettura ventesimale



	A max mm	L mm	€		
1650FT/1	350	438	335,00	1	016500060
1650FT/2	500	550	585,00	1	016500070

1651DGT

calibro digitale a corsoio lettura centesimale



UNI EN ISO 13385-1DIN 862CE

A Max mm	L mm	€		
150	225	107,00	1	016510111
200	285	126,00	1	016510112

1651DGT/IP

calibro digitale a corsoio lettura centesimale grado di protezione IP67

Totale protezione dalle polveri e dai liquidi, funziona anche in caso di totale immersione dello strumento.



UNI EN ISO 13385-1 DIN 862CE

1651DGT/IP	€ 254,00	1	016510611
------------	----------	---	-----------

270x115x35 mm - 450 g

1652

calibro a corsoio con comparatore lettura cinquantesimale



UNI EN ISO 13385-1DIN 862

1652	€ 108,50	1	016520016
------	----------	---	-----------

1654

calibri a corsoio lettura cinquantesimale



UNI EN ISO 13385-1DIN 862

A max mm	L mm	€		
200	330	237,00	1	016540020
300	410	322,00	1	016540030

1654DGT

calibro digitale a corsoio lettura centesimale

- Lettura centesimale
- Bloccaggio a vite del corsoio
- Conversione mm/pollici

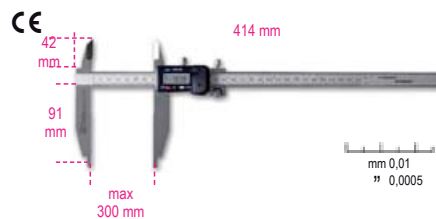

UNI EN ISO 13385-1DIN 862CE

1654DGT	€ 542,00	1	016540111
---------	----------	---	-----------

1656

calibri a corsoio di profondità lettura cinquantesimale



UNI EN ISO 13385-2DIN 862

A max mm	L mm	€		
200	260	112,50	1	016560020
300	360	165,00	1	016560030

1657DGT/2

calibro a corsoio di profondità digitale
lettura centesimale

- Lettura centesimale
- Bloccaggio a vite del corsoio
- Conversione mm/pollici

CE



UNI EN ISO 13385-2DIN 862CE

	A max mm	L mm	€		
1657DGT/2	200	270	209,50	1	016570002

1658/...

micrometri per esterni
lettura centesimale



DIN 863/II

	A mm	€		
1658/25	0÷25	64,50	1	016580025
1658/50	25÷50	70,50	1	016580050
1658/75	50÷75	79,50	1	016580075
1658/100	75÷100	87,00	1	016580100

1658/C4

assortimento di 4 micrometri 1658



DIN 863

1658/C4		259,00	1	016580001
---------	--	--------	---	-----------

1658/25	0÷25 mm
1658/50	25÷50 mm
1658/75	50÷75 mm
1658/100	75÷100 mm

365x245x35 mm - 2,5 kg

1658DGT

micrometri digitali per esterni
lettura millesimale

CE



DIN 863CE

	A mm	€		
1658DGT25	0÷25	292,00	1	016580325
1658DGT50	25÷50	334,00	1	016580350

1658SP/1

supporto per micrometro

- Morsetto con inserti in gomma
- Rotazione a 90°



1658SP/1		45,50	1	016580910
----------	--	-------	---	-----------

1659

misuratore di spessore
con comparatore
lettura centesimale

C = Campo di comparazione



	C mm	€		
1659	0÷10	166,00	1	016590001

1662/1 - 1662/2

comparatori
lettura centesimale

C = Campo di comparazione



DIN 878

	C mm	€		
1662/1	0÷5	75,50	1	016620001
1662/2	0÷10	93,00	1	016620010

1662DGT/A

comparatore digitale
lettura centesimale

C = Campo di comparazione

CE



	C mm	€		
1662DGT/A	0-12,5	230,00	1	016620311

1662AN

comparatore a tastatore orientabile
lettura centesimale

C = Campo di comparazione



DIN 2270

	C mm	€		
1662AN	0÷0,8	180,00	1	016620200

1662SP0

supporto a base magnetica



1662SP0		64,00	1	016620800
---------	--	-------	---	-----------

Beta

Beta

1662SP2

supporto a base magnetica
snodato



1662SP2 € 116,00 1 016620910

1666

squadre semplici
in acciaio inossidabile
rettificate e lappate



DIN 875/0

L mm	L1 mm	€		
100	70	52,50	1	016660210
150	100	75,50	1	016660215
200	130	91,00	1	016660220
250	165	118,00	1	016660225
300	200	148,50	1	016660230

1666A

squadre a cappello
in acciaio inossidabile
rettificate e lappate



DIN 875/0

L mm	L1 mm	€		
100	70	76,50	1	016660110
150	100	104,00	1	016660115
200	130	146,50	1	016660120
250	170	182,00	1	016660125
300	200	230,00	1	016660130

1668

squadre semplici
in acciaio normalizzato
rettificate



DIN 875/2

L mm	L1 mm	€		
100	70	23,30	2	016680210
150	100	32,00	2	016680215
200	130	40,00	2	016680220
250	165	58,50	1	016680225
300	174	72,00	1	016680230

1668A

squadre a cappello
in acciaio normalizzato
rettificate



DIN 875/2

L mm	L1 mm	€		
100	70	28,00	2	016680110
150	100	42,50	2	016680115
200	130	54,00	2	016680120
250	165	77,50	1	016680125
300	176	93,00	1	016680130

1670

squadre semplici
in acciaio non normale



L mm	L1 mm	€		
100	70	14,40	3	016700010
150	100	14,90	3	016700015
200	130	16,90	3	016700020
250	160	18,50	3	016700025
300	175	20,50	3	016700030
400	230	31,00	2	016700040
500	280	34,00	2	016700050
600	330	36,00	2	016700060
800	420	48,50	1	016700080
1000	500	58,50	1	016700099

1670A

squadre a cappello
in acciaio non normale



L mm	L1 mm	€		
100	70	19,00	3	016700110
150	100	20,50	3	016700115
200	130	22,50	3	016700120
250	165	27,00	3	016700125
300	175	32,00	3	016700130
400	230	41,00	2	016700140
500	280	55,00	2	016700150
600	330	62,00	2	016700160
800	420	73,50	1	016700180
1000	500	91,00	1	016700199

1672

squadra falsa
a lama orientabile e scorrevole
lama e base in acciaio

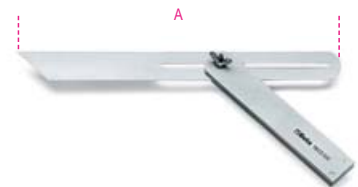

A mm	€		
300	44,50	2	016720030

1672A

squadre false
a lama orientabile e scorrevole
lama in acciaio cromata
base in alluminio

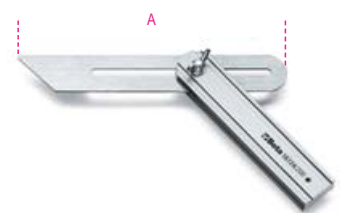

A mm	€		
200	23,00	3	016720120
300	25,00	3	016720130





1674A

squadre per falegnami
lama in acciaio, base in alluminio
doppia scala millimetrata



L mm	L1 mm	€	📦	📄
300	169	21,80	2	016740130
400	214	27,50	2	016740140

1676

goniometri semplici
in acciaio

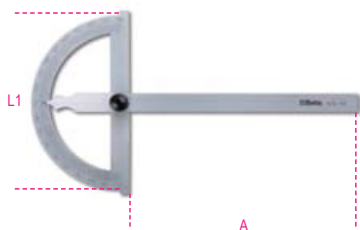

A °	A mm	L1 mm	G mm	€	📦	📄
120	120	80	1°	34,50	2	016760012
150	165	120	1°	39,50	2	016760015
200	210	150	1°	47,50	2	016760020
300	310	200	1°	64,00	1	016760030

1678/C3

rapportatore d'angoli
in acciaio inossidabile

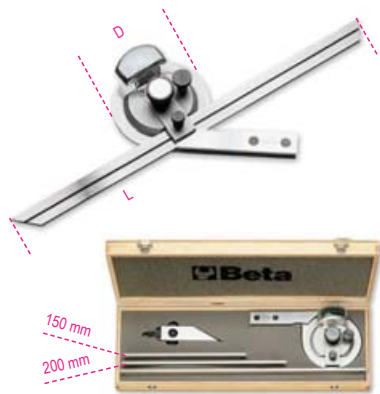

L Max mm	D mm	€	📦	📄
1678/C3	300	70	244,00	1 016780030

1679

calibro a tracciare con rotella
in acciaio inossidabile
lettura decimale

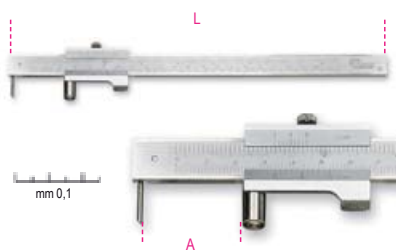

L mm	A Max mm	€	📦	📄
1679	235	200	74,00	1 016790020

1679/PR

punta di ricambio per calibro 1679



1679/PR	€	📦	📄
	11,90	1	016790021

1680

compasso a verga
corpo e punte di tracciatura
in acciaio temprato

• Regolazione fine cinquantalesimale

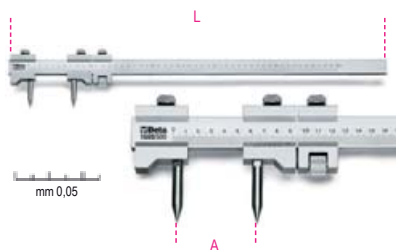

L mm	A Max mm	€	📦	📄
1680	660	500	244,00	1 016800050

1680A

compassi di precisione per interni



L mm	A Max mm	€	📦	📄
1680A	150	144	15,90	2 016800115
	200	200	19,50	2 016800120
	250	245	24,00	1 016800125
	300	300	28,00	1 016800130



1680B

compassi di precisione per esterni



L mm	A Max mm	€	📦	📄
1680B	150	155	15,90	2 016800215
	200	190	19,50	2 016800220
	250	235	24,00	1 016800225
	300	280	28,00	1 016800230

1680C

compassi di precisione per tracciatori
punte diritte in acciaio temprato



L mm	A Max mm	€	📦	📄
1680C	150	138	15,90	2 016800315
	200	190	19,50	2 016800320
	250	235	24,00	1 016800325
	300	280	28,00	1 016800330

1682

righe flessibili graduate
in acciaio inossidabile
• doppia scala millimetrata
• antiriflesso

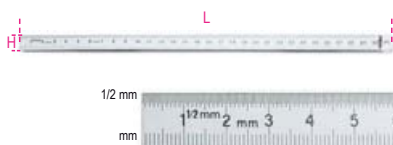

L mm	H mm	±0,05 mm	€	📦	📄
1682	150	13	0,5	2,55	5 016820015
	200	13	0,5	2,80	5 016820020
	250	13	0,5	3,40	5 016820025
	300	13	0,5	4,30	5 016820030
	500	13	0,5	9,50	2 016820050
	1000	13	0,5	25,00	2 016820100

1683

righe semirigide graduate
in acciaio inossidabile
• doppia scala millimetrata
• antiriflesso

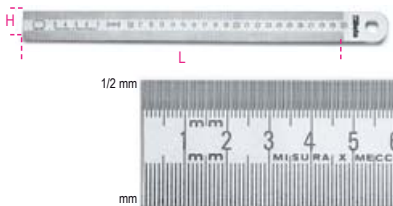

L mm	H mm	±0,05 mm	€	📦	📄
1683	300	30	1	7,50	5 016830030
	500	30	1	12,60	2 016830050
	1000	30	1	32,00	2 016830100
	1500	30	1	71,50	1 016830150

1685/C7

assortimento di 7 strumenti per misurare e tracciare



1685/C7 € 250,00 1 016850110

1650	160 mm
1658/25	0+25 mm
1670	100 mm
1680C	150 mm
1682	150 mm
1688BC	165 mm
1688BC/R	

320x210x37 mm - 1,2 kg

1687A

punta di precisione piegata a 90° con impugnatura



1687A L mm 153 L1 mm 80 € 5,40 1 016870120

1687AC

punta di precisione piegata corta con impugnatura



1687AC L mm 153 L1 mm 80 € 5,40 1 016870125

1687D

punta di precisione diritta con impugnatura



1687D L mm 153 L1 mm 80 € 5,40 1 016870110

1687U

punta di precisione ad uncino con impugnatura



1687U L mm 153 L1 mm 80 € 5,40 1 016870115

1687/S4

serie di 4 punte di precisione con impugnatura



1687/S4 € 21,60 1 016870150
1687A-1687AC
1687D-1687U

1688

punta per tracciare in acciaio temprato



1688 L mm 250 Ø mm 2 € 7,10 5 016880020

1688A

punta per tracciare in acciaio temprato con punte in carburo di tungsteno



1688A L mm 200 Ø mm 4 € 12,80 5 016880120

1688PC

punta per tracciare a penna in acciaio temprato cromato



1688PC L mm 150 Ø mm 1 € 31,00 1 016880300

1688PC/R

punta di ricambio per 1688PC



1688PC/R € 8,90 1 016880310

1688M

matita per falegnami



1688M L mm 180 € 0,92 50 016880880

1690F

metro pieghevole in fibra di vetro classe di precisione III



1690F/2 L m 2 S mm 17 € 10,00 5 016900220

1690L

metro pieghevole in legno di betulla classe di precisione III



1690L/2 L m 2 S mm 17 € 11,00 5 016900200

1691BM

flessometri
cassa bimateriale in ABS antiurto
nastro in acciaio
classe di precisione II

CE



1691BM/5 L m 5 S mm 25 € 13,20 1 016910205
1691BM/8 L m 8 S mm 32 € 19,80 1 016910208
1691BM/10 L m 10 S mm 32 € 24,00 1 016910210

1692

flessometri
cassa bimateriale in ABS antiurto
nastro in acciaio
classe di precisione II

CE



1692/2 L m 2 S mm 16 € 6,40 5 016920052
1692/3 L m 3 S mm 16 € 8,00 5 016920053
1692/5 L m 5 S mm 19 € 11,40 5 016920055
1692/8 L m 8 S mm 25 € 16,50 5 016920058

1693

misuratore di distanza laser
20 metri

MISURAZIONI:

- misura di distanza singola
- misura continua o misurazione minima

Auto spegnimento

Durata batteria: fino a 4.000 misurazioni
Custodia morbida in tela (inclusa)

CE
IP54



DATI TECNICI

Campo di misurazione: da 0,05 a 20m (da 0.2in a 66f)

Selezione scala: m, in, ft

Precisione: $\pm 1,5$ mm (± 0.06 in)

Classe Laser: 2

Batterie: AAA 2 x 1.5V

	H mm	L mm	S mm	€		
1693 20	100	36	23	102,00	1	016930020

1693M

misuratore di distanza laser, multifunzione
80 metri

MISURAZIONI:

- misura di distanza singola
- misura continua o misurazione minima

FUNZIONI:

- Addizione/sottrazione
- misura dell'area
- misura del volume
- misurazione indiretta variabile (misurazione pitagorica)
- Misurazione inclinazione

Auto spegnimento

Durata batteria: fino a 4.000 misurazioni
Custodia morbida in tela (inclusa)

CE
IP54



DATI TECNICI

Campo di misurazione: da 0,05 a 80m (da 0.2in a 229f)

Selezione scala: m, in, ft

Precisione: $\pm 1,5$ mm (± 0.06 in)

Classe Laser: 2

Memorizzazione misure: 99

Batterie: AAA 2 x 1.5V

	H mm	L mm	S mm	€		
1693M 80	115	48	29	172,00	1	016930080

1694/L

rotelle metriche
cassa in ABS antiurto
nastro in fibra di vetro ricoperto in PVC
classe di precisione III

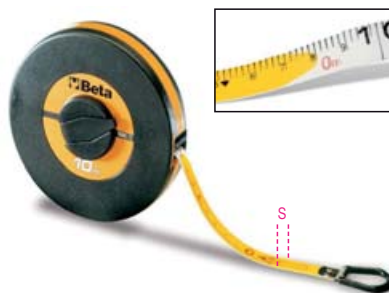

	L m	S mm	€		
1694L10	10	13	10,70	1	016940110
1694L20	20	13	13,20	1	016940120

1694A/L

rotelle metriche con impugnatura
cassa in ABS antiurto
nastro in fibra di vetro ricoperto in PVC
classe di precisione III



	L m	S mm	€		
1694A/L30	30	13	26,50	1	016940230
1694A/L50	50	13	34,50	1	016940250

1694B/L

rotella metrica con impugnatura
cassa in alluminio
nastro in acciaio smaltato
classe di precisione II



	L m	S mm	€		
1694B/L50	50	12,5	53,00	1	016940350

1695XS

livella tascabile con base a "V"
magnetica in alluminio profilato
2 filee infrangibili
precisione 1mm/m

- ideale per tubi e sezioni tonde in genere
- fornita con clip



	L mm	H mm	S mm	€		
1695XS	70	48,5	20	10,80	5	016950250

1696

livelle in alluminio profilato anodizzato
con filee infrangibili
precisione 1 mm/m



	L mm	H mm	S mm	€		
1696	200	50	19	18,20	2	016960002
	400	50	19	21,00	2	016960004
	500	50	19	22,80	2	016960005
	600	50	19	24,50	2	016960006
	800	50	19	31,00	2	016960008
	1000	50	19	34,00	2	016960010

1696A

livelle in alluminio pressofuso
con 1 base rettificata a 2 filee infrangibili
precisione 1 mm/m



	L mm	H mm	S mm	€		
1696A	300	43	23	26,00	2	016960103
	400	43	23	28,00	2	016960104
	500	43	23	30,50	2	016960105
	600	43	23	33,00	2	016960106
	800	43	23	53,00	1	016960108
	1000	43	23	66,50	1	016960110

1696B

livelle con base magnetica
in alluminio profilato
anodizzato a 2 filee infrangibili
precisione 1 mm/m



	L mm	H mm	S mm	€		
1696B	200	49	22	28,50	2	016960202
	300	49	22	30,00	2	016960203
	400	49	22	31,50	2	016960204
	500	49	22	38,00	2	016960205
	600	49	22	39,50	2	016960206



1696D

livelle in alluminio pressofuso con impugnature, (tranne la versione da 300 mm)
4 basi rettificata 3 file infrangibili
precisione 1 mm/m



L mm	H mm	S mm	€	Impugnatura	Articolo
300	47	25	24,50	2	016960353
400	47	25	28,00	2	016960354
500	47	25	30,50	2	016960355
600	47	25	34,00	2	016960356

1696S

stadio in alluminio con impugnature a due file infrangibili
precisione 1 mm/m



L mm	H mm	S mm	€	Impugnatura	Articolo
1500	90	25	87,00	1	016960415
2000	90	25	103,00	1	016960420
2500	90	25	129,00	1	016960425
3000	90	25	146,00	1	016960430

1699L

livella lineare di precisione in ghisa con base prismatica rettificata a 2 file infrangibili
precisione 0,05 mm/m



DIN 877

L mm	A mm	€	Impugnatura	Articolo	
1699L	200	49	259,00	1	016990002

1699L/1

livella lineare di precisione in ghisa con base prismatica rettificata a 2 file infrangibili
precisione 0,02 mm/m



DIN 877

L mm	A mm	€	Impugnatura	Articolo	
1699L/1	200	49	276,00	1	016990005

1699Q

livelle quadre di precisione in ghisa con 2 basi prismatiche e 2 basi piane rettificata a 2 file infrangibili
precisione 0,05 mm/m



DIN 877

L mm	A mm	€	Impugnatura	Articolo	
1699Q	150	40	368,00	1	016990015
	200	48	460,00	1	016990020

1700N

punte per edilizia



L mm	S mm	€	Impugnatura	Articolo	
1700N	250	16	13,40	5	017000005
	300	16	14,50	5	017000006

1700N/PM

punte per edilizia con paramano



L mm	S mm	€	Impugnatura	Articolo	
1700N/PM	250	16	18,00	2	017000105
	300	16	20,80	2	017000106

1701N

scalpelli per edilizia



L mm	A mm	S mm	€	Impugnatura	Articolo
1701N	250	23	16	5	017010001
	300	23	16	5	017010003

1701N/PM

scalpelli per edilizia con paramano



L mm	A mm	S mm	€	Impugnatura	Articolo
1701N/PM	250	23	16	2	017010101
	300	23	16	2	017010103

1701PMR

paramano per 1700N e 1701N



D mm	L mm	€	Impugnatura	Articolo	
1701PMR	16	115	8,70	1	017010206

1701NE/...

scalpelli per elettricisti



Articolo	SxL mm	€	Impugnatura	Articolo
1701NE3	10x200	8,90	5	017010406
1701NE4	10x250	9,40	5	017010409

1702N

scalpelli a tagliente extrapiatto



A mm	SxH mm	€	Impugnatura	Articolo	
1702N	50	12x25	18,90	2	017020005
	70	12x25	19,30	2	017020007

1702N/PM

scalpelli a tagliente extrapiatto con paramano



A mm	SxH mm	€	Impugnatura	Articolo	
1702N/PM	50	12x25	23,00	2	017020105
	70	12x25	25,00	2	017020107



Si raccomanda di raffreddare frequentemente l'utensile durante la riaffilatura.

1702PMR

paramano per 1702N



L mm	€	Impugnatura	Articolo	
1702PMR	115	6,70	1	017020200

1704

leve piegate per carpentieri

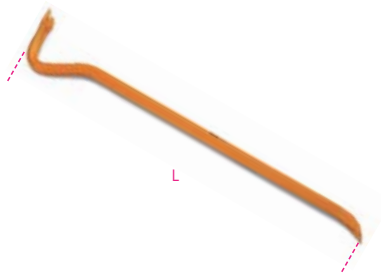

L mm	6 mm	1 mm	mm	€		
500	16	35	28	24,20	2	017040050
600	16	34	26	27,50	2	017040060
800	18	38	29	38,50	2	017040080

1704A

leve con estremità a punta e a scalpello

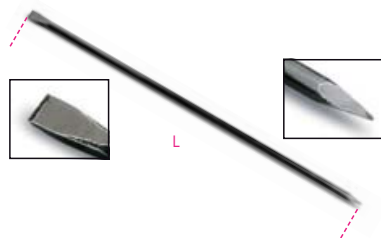

L mm	6 mm	mm	€		
1500	25	45	67,50	1	017040110
2000	28	55	96,50	1	017040120

1704C

leve con estremità a punta e penna chiusa



L mm	8 mini-MAX mm	mm	€		
1200	21-31	39	83,00	1	017040210
1400	31-37	42	99,00	1	017040212
1600	25-37	42	123,00	1	017040215

1705

traccialinea in alluminio



L m	€		
1705 30	16,20	4	017050001

1705PT

polvere traccialinea



g	€		
250	10,40	5	017050025

1706DGT

calibro digitale di profondità per battistrada pneumatici



1706DGT	€		
	31,00	1	017060011

1707

contafiletti

Per filetti metrici ISO a 60° e Whitworth a 55°



P (ISO)	W	€		
0,25÷6	62÷4x1"	14,50	5	017070001

1707A/1-2-3

raggimetri lame concave e convesse, in acciaio



	R mm	L mm	n	€		
1707A/1	1,0÷7,0	70	34	22,50	2	017070007
1707A/2	7,5÷15	85	32	24,30	2	017070015
1707A/3	15,5÷25	85	30	24,30	2	017070025



1708/8-13-20

spessimetri



	€		
1708/8 S = 0,05÷0,50 mm	5,50	5	017080008
1708/13 S = 0,05÷1,00 mm	6,20	5	017080013
1708/20 S = 0,05÷1,00 mm	10,00	5	017080020

1709/10-1709/18

spaccadadi



	L mm	A max mm	€		
1709/10	90	17 (M10)	44,50	1	017090010
1709/18	108	25 (M16)	48,50	1	017090018

1710

spaccadadi idraulico



	C min mm	C max mm	€		
	7 (M4)	22 (M14)	202,00	1	017100001

1712E/1-2-3

flessibili magnetici

F = forza magnetica

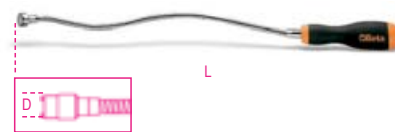

	L mm	D mm	F kg	€		
1712E/1	420	7,5	0,5	26,00	2	017120011
1712E/2	530	15	1,8	33,00	2	017120012
1712E/3	532	19	3,0	40,50	2	017120013

1712E/L1

flessibile magnetico con illuminazione LED

F = forza magnetica
pile: 2X LR48

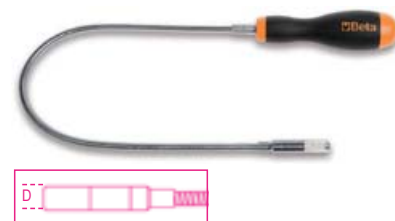

	L mm	D mm	F kg	€		
1712E/L1	500	11	0,75	36,50	2	017120111

1712E/R-L1

testine di ricambio per 1712E/L1, con LED e magnete

1712E/R-L1	€ 16,40	1	017120611
------------	---------	---	-----------

1712TF

magnete telescopico con testa flessibile

• Con pulitore per ugelli lavavetri
F= forza magnetica



L mm	D mm	F kg	€		
150÷590	11	1	17,30	1	017120600

1713M

artigli prensili flessibili

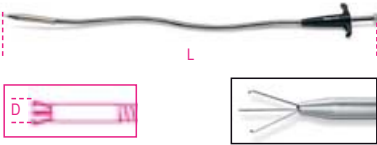

L mm	D mm	€		
500	7	36,00	2	017130011
1000	7	63,50	1	017130015

1714

specchietto rigido in materiale plastico



L mm	D mm	€			
1714	155	25	3,20	5	017140001

1715

specchietto telescopico articolato corpo in metallo cromato



L mm	D mm	€			
1715	180÷540	30	27,50	1	017150001

1715FL/A

specchietto flessibile rettangolare



L mm	A mm	B mm	€			
1715FL/A	600	53	90	32,50	1	017150110

1715R/FL

kit di 2 specchietti di ricambio per 1715FL/A e 1715FL/B

1715R/FL	€ 6,90	1	017150151
----------	--------	---	-----------

1715FL/B

specchietto flessibile rettangolare con illuminazione pile: 2X AAA

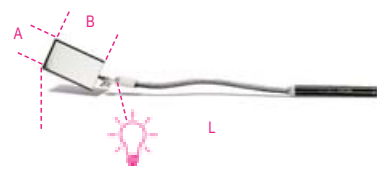

L mm	A mm	B mm	€			
1715FL/B	553	53	90	39,00	1	017150115

1715B/R5L

kit di 5 lampadine di ricambio per 1715FL/B

1715B/R5L	€ 5,60	1	017150152
-----------	--------	---	-----------

1716A

punta angolata per usi generici

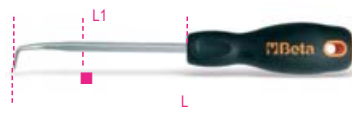

L mm	L1 mm	mm	€			
1716A	240	125	6	9,30	3	017160040

1716P

raschietto per guarnizioni



L mm	L1 mm	mm	€			
1716P	250	125	6	11,50	3	017160020

1716Q

punteruolo a punta quadra



L mm	L1 mm	Ø mm	€			
1716Q	215	100	6	8,00	5	017160010

1716R

punteruolo a punta tonda



L mm	L1 mm	Ø mm	€			
1716R	215	100	6	8,00	5	017160001

1716U

punta ad uncino per usi generici

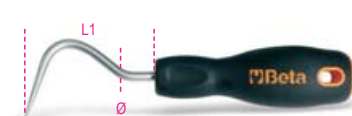

L mm	L1 mm	Ø mm	€			
1716U	195	80	6	9,30	3	017160025

1717A

raschietti a due taglienti



L mm	L1 mm	L2 mm	€		
150	70	260	17,60	2	017170015
200	75	310	18,90	2	017170020
250	100	360	20,80	2	017170025

1717B

raschietti a tre taglienti



L mm	L1 mm	L2 mm	€		
150	75	260	15,20	2	017170115
200	85	310	17,70	2	017170120
250	100	360	19,80	2	017170125

1717C

raschietti piatti



L mm	S mm	L1 mm	€		
150	18	270	15,00	2	017170215
200	20	320	16,90	2	017170220
250	25	370	19,00	2	017170225

1717D

raschietto piatto a tagliente frontale



L mm	S mm	L1 mm	€			
1717D	150	23	240	20,50	2	017170320

1717T

raschietti con lama triangolare completa di 2 lame



1717T	L 310	€ 9,50	1	017170610
-------	-------	--------	---	-----------

1717T RT

lame triangolari di ricambio



1717T RT	L mm 65	€ 2,00	1	017170660
----------	---------	--------	---	-----------

1717T RS

lame sagomate di ricambio



1717T RS	€ 2,00	1	017170661
----------	--------	---	-----------

1717V

raschietti per vernici
con lama utilizzabile su più lati



1717V 38	L 200	A 38	€ 6,50	1	017170703
1717V 65	L 285	A 65	€ 13,90	1	017170706

1717V R

lame di ricambio per 1717V



1717V R38	L 38	€ 2,00	1	017170753
1717V R65	L 65	€ 2,90	1	017170756

1718D...Q

lime quadre a taglio **grossolano**, senza impugnatura

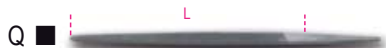

1718D6/Q	L 150	L" 6	€ 7,60	5	017180121
1718D8/Q	L 200	L" 8	€ 9,10	5	017180131
1718D10/Q	L 250	L" 10	€ 12,30	5	017180141

1718A...Q

lime quadre a taglio **mezzodolce**, senza impugnatura

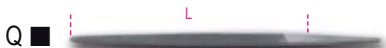

1718A6/Q	L 150	L" 6	€ 7,80	5	017180021
1718A8/Q	L 200	L" 8	€ 9,40	5	017180031
1718A10/Q	L 250	L" 10	€ 12,90	5	017180041

1718D...T

lime triangolari a taglio **grossolano**, senza impugnatura



1718D6/T	L 150	L" 6	€ 9,20	5	017180123
1718D8/T	L 200	L" 8	€ 11,70	5	017180133
1718D10/T	L 250	L" 10	€ 15,40	5	017180143

1718A...T

lime triangolari a taglio **mezzodolce**, senza impugnatura



1718A6/T	L 150	L" 6	€ 9,40	5	017180023
1718A8/T	L 200	L" 8	€ 12,00	5	017180033
1718A10/T	L 250	L" 10	€ 16,20	5	017180043

1718D...P

lime piatte a taglio **grossolano**, senza impugnatura



1718D6/P	L 150	L" 6	€ 7,20	5	017180125
1718D8/P	L 200	L" 8	€ 8,50	5	017180135
1718D10/P	L 250	L" 10	€ 11,40	5	017180145

1718A...P

lime piatte a taglio **mezzodolce**, senza impugnatura



1718A6/P	L 150	L" 6	€ 7,60	5	017180025
1718A8/P	L 200	L" 8	€ 8,80	5	017180035
1718A10/P	L 250	L" 10	€ 12,30	5	017180045

1718D...M

lime mezzotonde a taglio **grossolano**, senza impugnatura



1718D6/M	L 150	L" 6	€ 10,10	5	017180127
1718D8/M	L 200	L" 8	€ 12,40	5	017180137
1718D10/M	L 250	L" 10	€ 16,20	5	017180147

1718A...M

lime mezzotonde a taglio **mezzodolce**, senza impugnatura



1718A6/M	L 150	L" 6	€ 10,30	5	017180027
1718A8/M	L 200	L" 8	€ 12,70	5	017180037
1718A10/M	L 250	L" 10	€ 17,00	5	017180047

1718D...R

lime tonde a taglio **grossolano**, senza impugnatura



1718D6/R	L 150	L" 6	€ 7,20	5	017180129
1718D8/R	L 200	L" 8	€ 8,50	5	017180139
1718D10/R	L 250	L" 10	€ 11,20	5	017180149

1718A...R

lime tonde a taglio **mezzodolce**, senza impugnatura



1718A6/R	L 150	L" 6	€ 7,60	5	017180029
1718A8/R	L 200	L" 8	€ 8,80	5	017180039
1718A10/R	L 250	L" 10	€ 11,80	5	017180049

1718D...S5

serie di 5 lime a taglio **grossolano**, senza impugnatura



1718D6/S5	L 150	L" 6	€ 41,50	1	017180130
1718D8/S5	L 200	L" 8	€ 50,00	1	017180140
1718D10/S5	L 250	L" 10	€ 66,50	1	017180150

1718A...S5

serie di 5 lime a taglio **mezzodolce**, senza impugnatura



1718A6/S5	L 150	L" 6	€ 42,50	1	017180030
1718A8/S5	L 200	L" 8	€ 51,50	1	017180040
1718A10/S5	L 250	L" 10	€ 70,00	1	017180050

1719BMD...Q

lime quadre a taglio **grossolano**, con impugnatura



1719BMD6/Q	L 150	L" 6	€ 10,50	5	017190191
1719BMD8/Q	L 200	L" 8	€ 11,60	5	017190221
1719BMD10/Q	L 250	L" 10	€ 15,80	5	017190241
1719BMD12/Q	L 300	L" 12	€ 20,50	3	017190325

1719BMA...Q

lime quadre a taglio **mezzodolce**, con impugnatura



1719BMA6/Q	L 150	L" 6	€ 10,60	5	017190021
1719BMA8/Q	L 200	L" 8	€ 12,50	5	017190052
1719BMA10/Q	L 250	L" 10	€ 16,50	5	017190071
1719BMA12/Q	L 300	L" 12	€ 24,10	3	017190311

1719BMX...Q

lime quadre a taglio **dolce**, con impugnatura



	L mm	L "	€	📦	🚚
1719BMX6/Q	150	6	11,30	5	017190022
1719BMX8/Q	200	8	14,50	5	017190053
1719BMX10/Q	250	10	19,60	5	017190072

1719BMD...T

lime triangolari a taglio **grossolano**, con impugnatura



	L mm	L "	€	📦	🚚
1719BMD6/T	150	6	12,40	5	017190193
1719BMD8/T	200	8	14,20	5	017190223
1719BMD10/T	250	10	19,20	5	017190243
1719BMD12/T	300	12	27,50	3	017190326

1719BMA...T

lime triangolari a taglio **mezzodolce**, con impugnatura



	L mm	L "	€	📦	🚚
1719BMA6/T	150	6	12,40	5	017190023
1719BMA8/T	200	8	15,40	5	017190054
1719BMA10/T	250	10	20,00	5	017190073
1719BMA12/T	300	12	29,00	3	017190313

1719BMX...T

lime triangolari a taglio **dolce**, con impugnatura



	L mm	L "	€	📦	🚚
1719BMX6/T	150	6	14,70	5	017190024
1719BMX8/T	200	8	19,20	5	017190055
1719BMX10/T	250	10	24,80	5	017190074

1719BMD...P

lime piatte a taglio **grossolano**, con impugnatura



	L mm	L "	€	📦	🚚
1719BMD6/P	150	6	10,50	5	017190195
1719BMD8/P	200	8	11,00	5	017190225
1719BMD10/P	250	10	15,50	5	017190245
1719BMD12/P	300	12	20,10	3	017190327

1719BMA...P

lime piatte a taglio **mezzodolce**, con impugnatura



	L mm	L "	€	📦	🚚
1719BMA6/P	150	6	11,00	5	017190025
1719BMA8/P	200	8	12,40	5	017190056
1719BMA10/P	250	10	16,10	5	017190075
1719BMA12/P	300	12	23,00	3	017190315

1719BMX...P

lime piatte a taglio **dolce**, con impugnatura



	L mm	L "	€	📦	🚚
1719BMX6/P	150	6	11,30	5	017190026
1719BMX8/P	200	8	14,70	5	017190057
1719BMX10/P	250	10	19,20	5	017190076

1719BMD...M

lime mezzotonde a taglio **grossolano**, con impugnatura



	L mm	L "	€	📦	🚚
1719BMD6/M	150	6	13,70	5	017190197
1719BMD8/M	200	8	14,70	5	017190227
1719BMD10/M	250	10	19,80	5	017190247
1719BMD12/M	300	12	28,00	3	017190328

1719BMA...M

lime mezzotonde a taglio **mezzodolce**, con impugnatura



	L mm	L "	€	📦	🚚
1719BMA6/M	150	6	14,20	5	017190027
1719BMA8/M	200	8	16,70	5	017190058
1719BMA10/M	250	10	21,30	5	017190077
1719BMA12/M	300	12	31,50	3	017190317

1719BMX...M

lime mezzotonde a taglio **dolce**, con impugnatura



	L mm	L "	€	📦	🚚
1719BMX6/M	150	6	15,10	5	017190028
1719BMX8/M	200	8	18,80	5	017190059
1719BMX10/M	250	10	26,00	5	017190078

1719BMD...R

lime tonde a taglio **grossolano**, con impugnatura



	L mm	L "	€	📦	🚚
1719BMD6/R	150	6	10,50	5	017190199
1719BMD8/R	200	8	10,80	5	017190229
1719BMD10/R	250	10	15,00	5	017190249
1719BMD12/R	300	12	19,90	3	017190329

1719BMA...R

lime tonde a taglio **mezzodolce**, con impugnatura



	L mm	L "	€	📦	🚚
1719BMA6/R	150	6	11,10	5	017190029
1719BMA8/R	200	8	12,20	5	017190060
1719BMA10/R	250	10	15,70	5	017190079
1719BMA12/R	300	12	20,90	3	017190319

1719BMX...R

lime tonde a taglio **dolce**, con impugnatura



	L mm	L "	€	📦	🚚
1719BMX6/R	150	6	12,70	5	017190031
1719BMX8/R	200	8	14,20	5	017190061
1719BMX10/R	250	10	19,20	5	017190081

1719BMA...B5

serie di 5 lime a taglio **mezzodolce**, con impugnatura in busta



	L mm	L "	€	📦	🚚
1719BMA8/B5	200	8	69,00	1	017190297
1719BMA10/B5	250	10	89,50	1	017190298

1719BMD...B5

serie di 5 lime a taglio **grossolano**, con impugnatura in busta



	L mm	L "	€	📦	🚚
1719BMD8/B5	200	8	62,50	1	017190303
1719BMD10/B5	250	10	85,50	1	017190305

1719BMD...S5

serie di 5 lime a taglio **grossolano**, con impugnatura



	L mm	L "	€		
1719BMD6/S5	150	6	57,50	1	017190200
1719BMD8/S5	200	8	62,50	1	017190230
1719BMD10/S5	250	10	85,50	1	017190250
1719BMD12/S5	300	12	115,50	1	017190363

1719BMA...S5

serie di 5 lime a taglio **mezzodolce**, con impugnatura



	L mm	L "	€		
1719BMA6/S5	150	6	59,50	1	017190030
1719BMA8/S5	200	8	69,00	1	017190070
1719BMA10/S5	250	10	89,50	1	017190080
1719BMA12/S5	300	12	128,50	1	017190361

1719BMX...S5

serie di 5 lime a taglio **dolce**, con impugnatura



	L mm	L "	€		
1719BMX6/S5	150	6	65,00	1	017190032
1719BMX8/S5	200	8	81,50	1	017190069
1719BMX10/S5	250	10	108,50	1	017190082

1719BMB/P

lime piatte a taglio universale
impugnatura in materiale plastico



L mm	L "	€		
250	10	24,60	5	017190152
300	12	29,50	5	017190153

1719BMC

lime mezzotonde e piatte **a mazzo**
impugnatura in materiale plastico



UNI 5569 - UNI 5568

	L mm	L "	€		
1719BMC/M 250	250	10	16,50	6	017190252
1719BMC/M 300	300	12	20,40	4	017190253
1719BMC/P 250	250	10	13,00	6	017190262
1719BMC/P 300	300	12	16,10	4	017190263

1719BM/RR

raspa tonda
impugnatura in materiale plastico



	L mm	L "	€		
1719BM/RR	200	8	13,60	5	017190351

1719BM/RL

raspa piatta
impugnatura in materiale plastico



	L mm	L "	€		
1719BM/RL	200	8	13,00	5	017190360

1719BMR

impugnatura per lime



	L mm	A mm	€		
1719BMR/0	95	25	3,00	10	017190950
1719BMR/0B	110	29	3,00	10	017190955
1719BMR/1	110	29	3,00	10	017190951
1719BMR/1B	110	29	3,00	10	017190953
1719BMR/2	123	31	3,00	10	017190952
1719BMR/2B	123	31	3,00	10	017190954

	mm	"		
1719BMR/0	100/150	4/6	▲▲	●●
1719BMR/0B	100/150	4/6	■●	●●
1719BMR/1	150/200	6/8	▲▲	●●
1719BMR/1B	150/200	6/8	■●	●●
1719BMR/2	250/300	10/12	▲▲	●●
1719BMR/2B	250/300	10/12	■●	●●



1720/...

lime ad ago
taglio **mezzodolce**
gambo Ø 3 mm

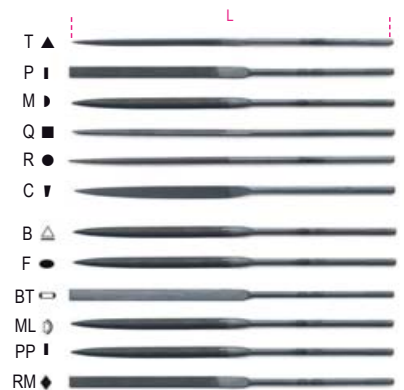

UNI 5569 UNI 5670

	L mm	€		
1720T	160	6,00	5	017200004
1720P	160	6,00	5	017200006
1720M	160	6,00	5	017200008
1720Q	160	6,00	5	017200009
1720R	160	6,00	5	017200010
1720C	160	6,00	5	017200012
1720B	160	6,00	5	017200005
1720ML	160	6,00	5	017200007
1720BT	160	6,00	5	017200011
1720F	160	6,00	5	017200013
1720PP	160	6,00	5	017200014
1720RM	160	6,00	5	017200015



	€		
1720/S3	18,00	1	017200000

1720/B



	€		
1720/B6	38,00	1	017200002
1720/B12	72,00	1	017200003

1720D/...

lime ad ago diamantate
grana D126



	L mm	€		
1720D/T	160	39,00	2	017200104
1720D/P	160	39,00	2	017200106
1720D/M	160	39,00	2	017200108
1720D/Q	160	39,00	2	017200109
1720D/R	160	39,00	2	017200110
1720D/C	160	39,00	2	017200112



1720D/B6 € 236,00 1 017200120

1721/B6

serie di 6 lime per contatti
in busta di plastica



1721/B6 € 20,00 1 017210010

1723

tenditore per molle



1723 L mm 210 € 12,90 5 017230001

1725

seghetto



1725 L mm 420 L1 mm 300 € 17,80 4 017250001

1725CR

miniseghetto



1725CR L mm 250 L1 mm 150 € 9,60 5 017250010

1726

seghetto
con sistema di tensionamento della lama
incorporato nell'impugnatura

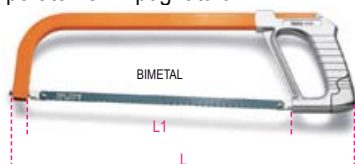

1726 L mm 440 L1 mm 300 € 23,80 4 017260001

1726BM

seghetto con sistema di tensionamento
della lama a sgancio rapido

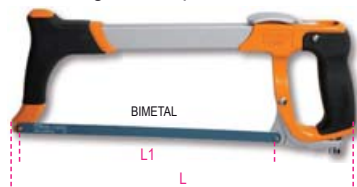

1726BM L mm 400 L1 mm 300 € 38,50 1 017260050

1727

seghetto tipo pesante



1727 L mm 515 L1 mm 300 € 16,40 4 017270001

1727BM

seghetto
portalama



1727BM L mm 315 L1 mm 300 € 19,80 5 017270020

1728...

lame per seghetti

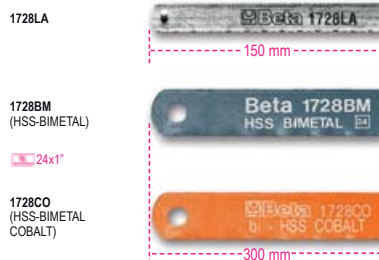

1728LA € 1,17 100 017280001

1725CR € 2,95 100 017280010

1728CO € 4,00 50 017280030

1729

segoncino ad arco

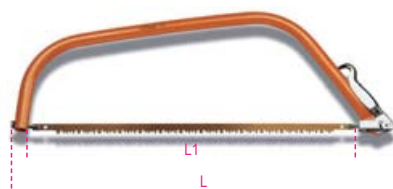

1729 L mm 710 L1 mm 610 € 19,50 5 017290001

1729LR

lama per segoncino 1729



1729LR € 5,00 10 017290010

1729CG

seghetto per cartongesso



1729CG L mm 310 L1 mm 160 € 19,50 2 017290200

1729DM 450

segaccio per legno

dentatura media, 12 denti per pollice



1729DM 450 L mm 450 L1 mm 400 € 22,50 4 017290450

1730

spatole universali con lama INOX e
impugnatura



S mm	L mm	L1 mm	€		
38	210	85	4,90	2	017300038
63	220	95	5,90	2	017300063
75	220	95	6,40	2	017300075
100	220	95	7,40	2	017300100

1730M

spatole per miscelatori
con lama INOX e impugnatura



L1 mm	L mm	S mm	€		
120	245	27	6,90	2	017300215
200	330	28	12,90	2	017300220
250	365	36	15,90	2	017300225

1730V 38

spatola per vetrai
lama a coltello in INOX



S mm	L mm	L1 mm	€		
38	225	100	4,90	2	017300338

1736A

spazzola per lime
filo in acciaio INOX
Ø filo 0,5 mm



L
mm
1736A 240 € 9,00 10 017360010

1737

spazzolino con fili di ottone ondulato
Ø filo 0,2 mm



L
mm
1737 145 € 4,40 10 017370001

1737NX

spazzola curva a fili di acciaio ottonato
Ø filo 0,3 mm



L
mm
1737NX 270 € 5,20 5 017370010

1737AC

spazzola a fili di acciaio
a 5 ranghi
Ø filo 0,3 mm



L
mm
1737AC 275 € 4,90 5 017370020

1737B

coppie di spazzole
per pulizia morsetti e
poli batteria veicoli
filo in acciaio
Ø filo 0,3 mm



1737B € 12,20 1 017370050

1738

pennello



L H
mm mm
1738 210 30 € 7,10 10 017380001

1739B

rivettatrice estensibile
fornita con 5 testine intercambiabili



max 830 mm

Ø mm	3,2	4	4,8	5	6	6,4
Alluminio	•	•	•	•	•	•
Inox	•	•	•	•		

1739B € 104,00 1 017390151

1740A

rivettatrice di potenza
fornita con 5 testine intercambiabili



525 mm

Ø mm	3,2	4	4,8	5	6	6,4
Alluminio	•	•	•	•	•	•
Inox	•	•	•	•		

1740A € 95,00 1 017400101

1740B

rivettatrice di potenza compatta
con serbatoio porta-steli
fornita con 5 testine intercambiabili



Ø mm	2,4	3	3,2	4	4,8
Alluminio	•	•	•	•	•
Acciaio	•	•	•	•	•
Inox	•	•	•	•	

L
mm
1740B 280 € 61,50 1 017400280

Ø mm	2,4	3,2	4,0	4,8	6,4
Alluminio	•	•	•	•	•
Acciaio	•	•	•	•	•
Inox	•	•	•	•	

L
mm
1740B 330 € 71,50 1 017400330

1741B

rivettatrice
fornita con 4 testine intercambiabili



250 mm

Ø mm	2,4	3,2	4	4,8	5
Alluminio	•	•	•	•	•
Acciaio	•	•	•	•	•
Inox	•	•	•		

1741B € 32,50 1 017410000

1741B/C5

rivettatrice 1741B con assortimento
di 700 rivetti in alluminio



1741B/C5 € 106,50 1 017410025

	Ø mm	L mm	n.
1741RV2,9K	3,0	6	200
1741RV3,2K	3,2	8	200
1741RV3,8K	4,0	10	100
1741RV4K	4,0	12	100
1741RV4,8K	4,8	12	100

415x155x60 mm - 3,1 Kg

1741BP

rivettatrice
fornita con 4 testine intercambiabili



260 mm

Ø mm	2,4	3,2	4	4,8	5
Alluminio	•	•	•	•	•
Acciaio	•	•	•	•	•
Inox	•	•	•	•	

1741BP € 49,00 1 017410350

1741U

rivettatrice ultra compatta con regolazione dello sforzo
fornita con 4 testine intercambiabili



200 mm

Ø mm	2,4	3	3,2	4	4,8
Alluminio	•	•	•	•	•
Acciaio	•	•	•	•	•
Inox	•	•	•	•	•

1741U € 38,50 1 017410450

1741RV...K

rivetti in alluminio



1741RV 2,9K	€ 15,50	1	017410191
ØxL = 3x6 mm			
1741RV 3,2K	€ 16,00	1	017410192
ØxL = 3,2x8 mm			
1741RV 3,8K	€ 20,00	1	017410193
ØxL = 4x10 mm			
1741RV 4K	€ 22,00	1	017410194
ØxL = 4x12 mm			
1741RV 4,8K	€ 27,50	1	017410195
ØxL = 4,8x12 mm			

I prezzi indicati sono relativi a 500 pezzi

1742

rivettatrice per inserti filettati
fornita con 4 testine intercambiabili
e 4 perni (1x M3;M4;M5;M6)



250 mm

1742 € 107,50 1 017420001

M	Ø mm	L mm
3	5	11
4	6	11
5	7	13
6	9	17

1742KR

kit di 4 perni di ricambio per 1742



M3	€ 40,50	1	017420043
M4	€ 40,50	1	017420044
M5	€ 40,50	1	017420045
M6	€ 40,50	1	017420046

1742R-AL/M...

rivetti in alluminio filettati per
1742-1742A-1946KF



1742R-AL M3	€ 3,80	1	017420023
ØxL = 5x10 mm M = 3			
1742R-AL M4	€ 3,90	1	017420024
ØxL = 6x12 mm M = 4			
1742R-AL M5	€ 4,20	1	017420025
ØxL = 7x13 mm M = 5			
1742R-AL M6	€ 5,10	1	017420026
ØxL = 9x15 mm M = 6			

I prezzi indicati sono relativi a 20 pezzi

1742R-A/M...

rivetti in acciaio filettati per
1742-1742A-1946KF



1742R-A M3	€ 4,00	1	017420013
ØxL = 5x11 mm M = 3			
1742R-A M4	€ 4,10	1	017420014
ØxL = 6x11 mm M = 4			
1742R-A M5	€ 4,40	1	017420015
ØxL = 7x13 mm M = 5			
1742R-A M6	€ 5,20	1	017420016
ØxL = 9x17 mm M = 6			
• 1742R-A M8	€ 4,90	1	017420018
ØxL = 11x17 mm M = 8			
• 1742R-A M10	€ 5,90	1	017420020
ØxL = 13x24 mm M = 10			

I prezzi indicati sono relativi a 20 pezzi
• I prezzi indicati sono relativi a 10 pezzi

1742/C4

rivettatrice 1742 con assortimento di 400 inserti filettati in acciaio



1742/C4 € 242,00 1 017420005

	M	Ø mm	n.
1742R-A/M3	3	5	100
1742R-A/M4	4	6	100
1742R-A/M5	5	7	100
1742R-A/M6	6	9	100

415x155x60 mm - 2,9 kg

1742A

rivettatrice di potenza per inserti filettati
fornita con 4 testine intercambiabili



533mm

1742A € 395,00 1 017420100

M	Ø mm	L mm
5	7	13
6	9	17
8	11	17
10	13	24

1742A/KR

kit di 4 perni di ricambio per 1742A

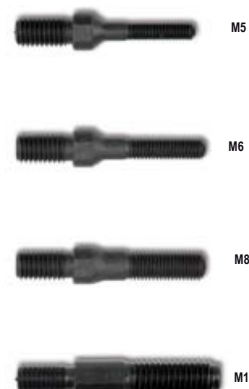

1742A/KR M5	M5	€ 28,00	1	017420143
1742A/KR M6	M6	€ 28,00	1	017420144
1742A/KR M8	M8	€ 28,00	1	017420145
1742A/KR M10	M10	€ 28,00	1	017420146



1742A/C

rivettatrice 1742A con assortimento di 60 inserti filettati in acciaio



1742A/C € 429,00 1 017420105

	M	mm	n.
1742R-A/M5	5	7	20
1742R-A/M6	6	9	20
1742R-A/M8	8	11	10
1742R-A/M10	10	13	10

536x310x80 mm - 2,1 kg

1743

pinza per fascette in Nylon

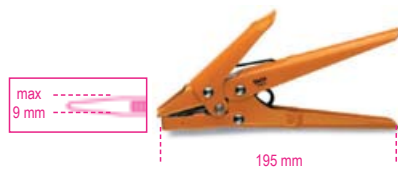

1743 € 46,00 1 017430001

1743T

pinza tagliafascette

• Adatta anche per il taglio di piccoli cavi (3x1.5mm²; 1x17mm²)



1743T € 27,00 1 017430100

1749

pistola per sigillante



1749 L min mm 340 € 11,40 2 017490001

1749A

pistola per sigillante modello professionale tubo in alluminio.

Capacità cartucce 310ml
Capacità sacchetti 310ml

Non idonea per utilizzo con sigillante sfuso.



1749A L min mm 360 € 35,50 1 017490010

1749A/RB

beccucci di ricambio per 1749A

1749A/RB € 0,82 2 017490051

1749A/RT

tappi frontali avvitabili per 1749A

1749A/RT € 1,80 1 017490052

1749AC

pistola ad alta spinta per ancoranti chimici e cartucce standard



1749AC L min mm 360 € 32,00 1 017490005

1750

compressori a leva per grasso

utilizzabile con cartucce 1750CG oppure con grasso sfuso



1 g, 550 bar Max

1750CG cc	L mm	€		
400	380	35,00	1	017500500
600	450	41,50	1	017500750

1750R/1 - 1750R/2

tubi flessibili di ricambio in Nylon



	L mm	€		
1750R/1	310	5,60	2	017500030
1750R/2	410	6,20	2	017500040

1750RC

tubo rigido piegato



	L mm	M mm	€		
1750RC	150	10x1	4,60	2	017500050

1750RT

testina a 4 griffe tipo "Hydraulic"



	M mm	€		
1750RT	10x1	4,10	5	017500110

1750RP/1 - 1750RP/2

testine per raccordi piatti



	Ø mm	M mm	€		
1750RP/1	16	10x1	10,10	2	017500115
1750RP/2	22	10x1	23,00	2	017500120

1750CG

cartucce di grasso universale per 1750

• Temperatura di impiego da -20°C a +130°C



cc	€		
400	12,40	18	017500140
600	15,50	18	017500160

1750KG10

ingrassatore a leva da 10 kg,
con tubo ad alta pressione da 2 m

dotato di raccordo girevole per non strozzare il tubo.
corpo pompante in alluminio pressofuso con valvola di sfiato

3 differenti livelli di pressione impostabili:

- 4 gr a 275 bar
- 7 gr a 206 bar
- 9 gr a 137 bar



1750KG10 € 159,00 1 017500100

1750TA

testina per ingrassaggio autobloccante a 6
spilli

- una volta posizionata rimane in asse e collegata al nipplo
- agevole disconnessione anche con testina in pressione.
- filetto M10x1: adatto a tutti i tipi di ingrassatore: elettrico, pneumatico, manuale, ecc.
- nessuna deformazione fino a 550 bar



1750TA € 37,50 1 017500111

1750TLA

testina per ingrassaggio autobloccante a 6
spilli, versione lunga

- una volta posizionata rimane in asse e collegata al nipplo
- agevole disconnessione anche con testina in pressione.
- filetto M10x1: adatto a tutti i tipi di ingrassatore: elettrico, pneumatico, manuale, ecc.
- nessuna deformazione fino a 550 bar



1750TLA € 49,50 1 017500112

1750M

mini ingrassatore

- Con microugello
- Particolarmente indicato per utensili pneumatici



1750M	cc	D mm	L mm	€	5	1	017500025
	100	43	145	18,50			

1751

oliatori metallici a pressione
cannuccia flessibile



cc	D mm	L mm	€	5	1	017510002
200	62	140	13,30			
300	75	140	14,40			
500	85	140	15,00			
750	100	140	16,50			
1000	100	140	17,80			

1751R

cannuccia di ricambio
per 1751



200÷1000 € 4,00 5 017510010

1752

oliatori in plastica a pressione
cannuccia rigida



cc	D mm	L mm	€	5	1	017520002
200	67	140	8,70			
300	77	140	9,30			
500	95	140	9,70			
700	95	140	10,40			

1752R

cannuccia di ricambio
per 1752



cc 200÷700 € 3,50 5 017520020

1753

oliatori in plastica a pressione
cannuccia flessibile



cc	D mm	L mm	€	5	1	017530002
200	65	190	8,80			
300	80	190	9,00			
500	95	190	9,30			
700	95	190	10,20			

1753R

cannuccia di ricambio
per 1753



cc 200÷700 € 3,60 5 017530020

1754

oliatori in plastica a pressione
cannuccia flessibile



cc	D mm	L mm	€	5	1	017540015
150	60	130	7,90			
250	65	130	8,90			

1755

oliatori in plastica
cannuccia rientrante



cc	L	A	€		
mm	mm	mm			
30	160	30	5,80	5	017550003
80	170	47	6,40	5	017550008
150	230	58	7,20	5	017550015

1756

oliatore a stilo



cc	L	€		
mm	mm			
5	140	18,80	2	017560001

1756B

siringa per olio

• Temperatura di funzionamento: -10°C - +60°C



cc	L	€		
mm	mm			
500	280	18,20	2	017560220

1756C

siringa per olio da 200 ml
in polipropilene

• Adatta anche al liquido impianto freni
• Doppia guarnizione in EPDM
• Temperatura di funzionamento: +0 - +50°C
• Non adatta per carburanti e oli minerali



1756C	€ 29,00	1	017560502
-------	---------	---	-----------

1756D

siringa per olio da 1500 ml
in polipropilene

• Doppia guarnizione in NBR
• Temperatura di funzionamento: +0 - +50°C
• Non adatta per carburanti

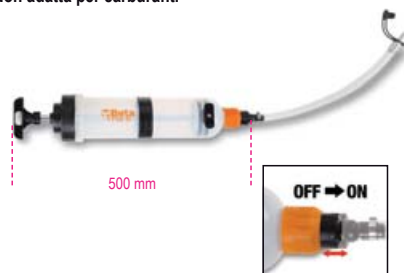

1756D	€ 65,00	1	017560515
-------	---------	---	-----------

1756G

siringa per gasolio
capacità 1,5 l

Utilizzabile per:
• riempimento filtri gasolio
• riempimento serbatoio cerina



Compresi nel kit:
• 2 tubi con attacchi rapidi femmina per collegamento tubi gasolio
• 2 attacchi rapidi maschio in metallo
• 1 adattatore conico per tubi gomma

1756G	€ 100,00	1	017560615
-------	----------	---	-----------

1756C-20R

coppia di O-ring per siringhe 1756C

1756C-20R	€ 3,70	1	017560503
-----------	--------	---	-----------

1756D-20R

coppia di O-ring per siringhe 1756D

1756D-20R	€ 6,10	1	017560516
-----------	--------	---	-----------

1757

rabboccatore per liquidi batterie



cc	D	€		
mm	mm			
250	60	2,95	4	017570002
500	75	3,50	4	017570004
1000	90	4,80	2	017570006

1757A

colmatore per liquidi batterie



cc 2000	€ 36,00	1	017570020
---------	---------	---	-----------

1758

imbuto autoadattante

particolarmente utile per auto
prive di profondità all'interno
del tappo di carico



1758	€ 45,50	1	017580020
------	---------	---	-----------

1758A

imbuto antiriflusso
con attacco rapido Ø 38 mm
Particolarmente indicato per vetture
del gruppo Volkswagen



1758A	€ 69,00	1	017580010
-------	---------	---	-----------

1758B

imbuto antiriflusso
con attacchi rapidi
Particolarmente indicato
per vetture gruppo VAG



1758B	€ 30,50	1	017580030
-------	---------	---	-----------

1758B-RNT

attacco rapido antiriflusso
per imbuto 1758B
per motore Renault 1.5 dCi



1758B-RNT € 21,50 1 017580035

1758LG

lamina modellabile in alluminio rivestita in
gomma, per la canalizzazione dei liquidi



L mm H mm € 38,50 1 017580006

1758M

imbuto



1758M L mm 350 € 11,30 1 017580000

1758R

recipienti per liquidi

pratico beccuccio flessibile removibile



1758R 3 lt € 14,90 1 017580203
1758R 5 5 € 18,30 1 017580205

1758VT

kit per la verifica delle testate

segnala rapidamente se nella vaschetta d'espansione è
presente anidride carbonica.



1758VT € 146,00 1 017580100

290x190x50 mm - 1kg

1758VT/L

liquido di contrasto per verifica testate



1758VT/L € 41,50 1 017580101

1759

analizzatore ottico per liquidi di
raffreddamento, batteria, lavavetri e AdBlue®
in astuccio rigido

Compensazione automatica della temperatura

Acido batteria: intervallo di misura

da 1,1 a 1,3 kg/l

Liquido di raffreddamento propilene:

da -25°C a -50°C

Liquido di raffreddamento etilene: da -25°C a -50°C

Liquido lavavetri: da -10°C a -40°C

AdBlue®: Misurazione percentuale di urea da 30% a 35%



1759 € 135,00 1 017590251

1759A

densimetro per liquido anticongelante



1759A L mm 340 € 57,00 1 017590001

1759B

densimetro per liquidi batteria



1759B L mm 280 € 37,50 1 017590005

1759HD/3

strumenti per controllo tenuta
impianto di raffreddamento e
riempimento circuito

Permette di verificare sotto pressione le perdite del circuito
(tubi, giunti, pompe, radiatori) e
riempire velocemente il circuito evitando la formazione di
bolle d'aria



1759HD/3 € 475,00 1 017590063

600x500x140 mm - 6,5 kg

1759HD/RR

strumento per riempimento
impianto di raffreddamento



1759HD/RR € 146,00 1 017590064

450x310x110 mm - 2,2 kg

1759HD/TRUCK

strumento per controllo e tenuta
impianto di raffreddamento Truck



1759HD/TRUCK € 330,00 1 017590065

440x330x100 mm - 3 kg

1759TT

kit 4 coppie tappi verifica circuito turbo
utilizzabile con pistole gonfiagomme



1759TT € 175,00 1 017590300

400x160x100 mm - 1,8 kg

1760DGT

multimetro digitale automotive



DATI TECNICI

RPM (tachimetro):

Per motori a 2 e 4 cilindri
RPM4 600 - 4000 RPM
RPM4 600 - 12000 RPM (x10 RPM)
RPM2/DIS 300 - 4000 RPM
RPM2/DIS 300 - 6000 RPM (x10 RPM)

Angolo Dwell: 4-8 CYL

Tensione DC: 400mV-4/40/400/1000V
Tensione AC: 4/40/400/700V
Corrente DC: 40/400mA-4/20A
Corrente AC: 40/400mA-4/20A

Resistenza: 400Ω-4/40/400kΩ-4/40MΩ

Capacità: 40/400nF-4/40/100μF

Frequenza: 5/50/500Hz-50/500-10MHz

Duty Cycle: 0.1 - 99,9%

Ampiezza pulsazioni: 1 - 10ms

Prova diodi: Corrente test 0,3mA

Continuità: <150Ω - Corrente test <0,3mA

Display: LCD ad alto contrasto 4 digit retro-illuminato

Sovratensione: Categoria II 1000V

Autospegnimento: 30 minuti

Alimentazione: 1 batteria 9V (inclusa)

Pinza induttiva (inclusa)

2 Puntali (inclusi)

Custodia morbida in tela (inclusa)

Manuale d'uso

1760DGT € 222,00 1 017600005



1760DGT/2

multimetro digitale automotive portatile
con oscilloscopio a 2 canali e generatore
d'onda



IL KIT INCLUDE:

- puntali multimetro
- 2 connettori cocodrillo BNC per oscilloscopio
- sonda a puntale per oscilloscopio (1X e 10X)
- caricabatteria
- custodia in nylon

DATI TECNICI

Display: TFT a colori da 2,8"

Risoluzione: 320 x 240 pixels

Alimentazione: 100V-240V AC, 50Hz-60Hz; DC INPUT 5V

DC-2A

Batteria: 2 x 2600 mAh

SPECIFICHE MULTIMETRO

Test: Tensione, Corrente, Resistenza, Capacità, Diodi e On-Off
Tensione Max: 600V DC
Corrente Max: 10A DC
Resistenza Max: 40MOHM
Capacità Max: 100uF

SPECIFICHE OSCILLOSCOPIO

Orizzontale

Larghezza banda: 40MHz

Intervallo di frequenza campionamento: 250MSa/s (singolo

canale) - 125MSa/s (doppio canale)

Gamma SEC/DIV: 5ns/div ÷ 500s/div 1,2,5 sequence

Verticale

Gamma VOLTS/DIV: 10mV/div=10V/div ingresso BNC

Analogo selezionabile limite larghezza di banda, tipico: 20MHz

Risposta a bassa frequenza (-3db): ≤10Hz a BNC

DC Gain Accuracy: ± 3% per la modalità di acquisizione Normale

o Media, da 10V/div a 10 mV/div

Trigger

Type: Edge

Mode: Auto, Normal, Single

Slope: Rising, Falling, Rising, & Falling

Source: CH1, CH2

Ingresso

Accoppiamento: DC, AC o GND

Fattori di attenuazione della sonda supportati: 1X, 10X, 100X,

1000X

Generatore di forma d'onda arbitraria

Frequenza forma d'onda: Sine (1Hz÷25MHz), Square

(1Hz÷10MHz), Ramp (1Hz÷MHz), EXP (1Hz÷5MHz)

Ampiezza: 2,5Vpp (50Ω) - 5Vpp (alta impedenza)

Impedenza di uscita: 50Ω

Dimensioni: 199 x 98 x 40 mm

Peso: 624g

1760DGT/2 € 620,00 1 017600008

1760B

multimetro digitale



CE

PARAMETRI RILEVABILI

Tensione DC: 200 mV-2/20/200/1000V
 Tensione AC: 2-20/200/700V
 Corrente DC: 2/20/200 mA-20 A
 Corrente AC: 2/200 mA- 20 A
 Resistenza: 200Ω - 2/20/200 kΩ - 2/20 MΩ
 Capacità: 2/20/200 nF - 2/200 μF
 Temperatura: -20° + 1000°C/ -4 °F ~ +2000°F
 Frequenza: 20kHz
 Alimentazione: 1 batteria da 9V (inclusa)

1760B € 144,00 1 017600012

1760/OHM

multimetro/megaohmetro per test isolamento ad alta tensione.

con lettura a valore efficace TRUE RMS



CE

CAT. IV
600V
CAT. III
1000V

	Campo di misura	Precisione base
Tensione AC/DC:	50mV - 1000V	±0.06% - ±0.1% rdg
Corrente AC/DC:	0.01μA - 10A	±0.5% - ±1% rdg
Resistenza:	0.01Ω - 50MΩ	±0.2% - ±2% rdg
Meg OHM:	0.01 - 5000MΩ	±4% rdg. max current
1mA		
Capacità:	5nF - 10mF	±1.5% - ±3% rdg
Frequenza:	50Hz - 100 MHz	±0.02% - ±0.1% rdg
Temperatura:	-50°C - +1350°C	±0.5% rdg
Test diodi:	3V dc	
Test continuità:	<30 Ω	

1760/OHM € 680,00 1 017600025

1760/RMS

multimetro industriale IP67

con lettura a valore efficace TRUE RMS



CE

Campo di misura Precisione base

Tensione AC/DC 110mV - 600V ±0.8% - ±2% rdg
 Corrente AC/DC 110μA - 10A ±1.5% - ±2% rdg
 Resistenza 110Ω - 40MΩ ±1.2% - ±2.5% rdg
 Capacità 11nF - 40mF ±5% - ±10% rdg (fino a 11mF)
 Frequenza 1100Hz - 110 MHz ±1.2% - ±1.5% rdg
 Temperatura -32°C - +1000°C ±3% - ±5% rdg
 Test diodi 3V dc ±10% rdg
 Test continuità <30 Ω

1760/RMS € 246,00 1 017600020

1760PA/80

pinza amperometrica AC/DC 80A

per misurazione di bassi valori di dispersione della corrente o assorbimenti sui veicoli



CE

- range: 1mA-80AAC/DC
- funzione torcia con LED bianco
- display LCD retroilluminato
- funzione azzeramento
- funzione Hold
- autospegnimento
- alimentazione: 2 batterie 1,5V tipo AAA

1760PA/80 € 185,00 1 017600002



1760PA/AC

pinza amperometrica e multimetro digitale

A: AC
V: AC/DC



CE

PARAMETRI RILEVABILI

Tensione DC: 400 mV - 4/40/400/600 V
 Tensione AC: 400 mV - 4/40/400/600 V
 Corrente AC: 40/400/1000 A
 Resistenza: 400Ω - 4/40/400 kΩ - 4/40 MΩ
 Frequenza: 5/50/500 Hz - 5/50/500 kHz - 5/10 MHz
 Capacità: 40/400 nF - 4/40/100 μF
 Temperatura: -20°C + 1000°C / -4 °F + 1832 °F
 Alimentazione: 1 batteria da 9V (inclusa)

1760PA/AC L mm 190 € 151,00 1 017600050

1760PA/AC-DC

pinza amperometrica e multimetro digitale

A: AC/DC
V: AC/DC



CE

PARAMETRI RILEVABILI

Tensione DC: 0.1mV ÷ 600V
 Tensione AC: 0.1mV ÷ 600V
 Corrente AC: 0.01A ÷ 1000A
 Corrente DC: 0.01A ÷ 1000A
 Resistenza: 0.1Ω ÷ 40MΩ
 Capacità: 0.001nF ÷ 40 μF
 Frequenza: 0.001kHz ÷ 4kHz
 Temperatura: -40°C ÷ 1000 °C -40°F ÷ 1832°F
 Alimentazione: 1 batteria da 9V (inclusa)

1760PA/AC-DC € 275,00 1 017600000

1760DGT-R3

puntali di ricambio per multimetri digitali e pinze amperometriche



1760DGT-R3 € 19,20 1 017600603

1760/RSE

rilevatore di segnale

Permette di testare l'alimentazione di componenti come: elettroiniettori Common Rail, elettroiniettori benzina/GPL, iniettori piezoelettrici, elettrovalvole regolatrici flusso/elettrovalvole EGR, bobine e altri



Per effettuare la diagnosi dei singoli componenti dell'impianto elettrico è sufficiente avvicinare la sonda al componente in esame.

In impianti con componenti elettromeccanici/elettronici comandati da una centralina, lo strumento permette di verificare se:

- la centralina di gestione è alimentata e assolve il suo compito di comando
- il cablaggio della centralina al componente è efficiente
- il componente in esame non è interrotto
- il componente non è in cortocircuito
- il componente è elettronicamente funzionante

1760/RSE € 385,00 1 017600170

1760/TC2

tachimetro digitale a distanza e a contatto



DATI TECNICI

- Per misurazione di:
 - rotazione a distanza (g/min - rpm)
 - rotazione (g/min - rpm) e velocità lineare (m/min o ft/min) a contatto.
- Display LCD a 5 cifre.
- Scala:
 - a distanza 2,5+99.999 g/min
 - a contatto 0,5+19.999 g/min
 - velocità lineare 0,05+1.999,9 m/min.
- Frequenza: 0,8 sec.
- Alimentazione: 4 batterie 1,5V (AA) (incluse) o alimentatore 6V (non incluso)
- Fornito con:
 - adattatore per misurazioni a contatto
 - 2 puntali maschio in gomma
 - 1 puntale femmina in gomma
 - 1 rotella per rilevazioni lineari
 - etichette riflettenti
 - manuale di istruzioni
 - custodia in plastica.

1760/TC2 L 230 mm H 74 mm € 192,00 1 017600161

1760R/TC2

etichette riflettenti per 1760/TC2



1760R/TC2 € 17,00 1 017600561

1760K

rilevatore di tensione AC senza contatto con mini torcia LED

campo: 200-1000Vac 50/60Hz
CAT III-1000V
funzionamento con 2 pile AAA (incluse)



1760K € 31,00 1 017600140

1760PT

tester combinato di tensione e continuità 12-690V AC/DC

- funzioni:
- continuità
 - rotazione fasi
 - cercafase
 - torcia LED



1760PT € 123,50 1 017600150

1760/IR500

termometro digitale ad infrarossi con doppio puntamento laser

non idoneo alla misurazione della temperatura corporea



DATI TECNICI

- Range temperatura: -50 + 500 °C (-22 a 932 °F)
- Risoluzione display: 0,1 °C (0,1 °F)
- Emissività: regolabile 0,1 + 1
- Precisione: -50 a 20°C (+/- 3°C); 20 + 500°C (+/-2% o 2°C)
- Risoluzione ottica (D:S): 12:1
- Auto Spegnimento: circa 10 secondi
- Temperatura di funzionamento: 0 + 50°C
- Temperatura di stoccaggio: -20 + 60°C
- Alimentazione: 1 batteria 9 V

1760/IR500 € 132,00 1 017600350

Beta

Beta

1760/IR1000

termometro digitale ad infrarossi con doppio puntamento laser

non idoneo alla misurazione della temperatura corporea



DATI TECNICI

Range temperatura: -50 ÷ 1000 °C (-58 ÷ 1832 °F)
Risoluzione display: 0,1°C (0,1°F)
Emissività: regolabile 0,1 ÷ 1
Precisione: -50 ÷ 20°C (+/- 3,5°C); 20 ÷ 300°C (+/-1% o 1°C);
300 ÷ 1000°C (+/-1,5%)
Risoluzione ottica (D:S): 20:1
Temperatura di funzionamento: 0 ÷ 50°C
Temperatura di stoccaggio: -10 ÷ 60°C
Alimentazione: 2 batterie 1,5 V (tipo AAA)

1760/IR1000 € 219,00 1 017600400

1760/IR1600

termometro digitale ad infrarossi con doppio puntamento laser

non idoneo alla misurazione della temperatura corporea



DATI TECNICI

Gamma: da -50°C a 1600°C / da -58°F a 2912°F
Selezione scala: °C/°F
Precisione: ±1,5% o ±2°C a 20°C
Potenza Laser: <1mW
Risposta: 150ms
Emissività: 0,10-1,0 regolabile
Rapporto distanza: (D:S) 50:1
Temperatura operativa: 0°C ÷ 50°C / 32°F ÷ 122°F
Umidità operativa: da 0% a 100% RH
Display LCD retro-illuminato
Funzione di mantenimento dei dati
Auto spegnimento
Presse tipo K
Presse mini USB
Cavo USB per scarico dei dati
CD per installazione software datalogger
Alimentazione: 1 batteria 9V (inclusa)

Custodia rigida e treppiede in alluminio
Manuale d'uso

1760/IR1600 mm mm € 610,00 1 017600461

1760TMC

termocamera ad infrarossi

Termocamera compatta per la misurazione della temperatura senza contatto, adatta per applicazioni nei settori edile, meccanica, impianti elettrici e di riscaldamento

- Temperatura da -20 ÷ +600°C.
- Display LCD TFT da 2 pollici 240x320.
- Sensore da 32x32 pixel.
- Frequenza di acquisizione 7Hz.
- Termosensibilità <347mK.
- Acquisizione automatica dei punti caldi e freddi.
- Fotocamera di acquisizione immagini in formato BMP (massimo 100 immagini).
- Emissività regolabile.
- Alimentazione 3 batterie alkaline AAA.
- Interfaccia USB.
- IP54
- Banda infrarossi 6.5÷14µm.
- Distanza di fusione visibile/infrarosso 0.5; 1; 2 m.
- Funzione allarme, selezionando la temperatura massima e minima accettabili.



1760TMC 600 € 695,00 1 017600710

1761

pinza torcifilo a ritorno automatico



L mm 255 € 54,00 1 017610101

1761RS/1

pinza torcifilo reversibile a ritorno automatico



L mm 220 € 96,50 1 017610130

1762

pinza fustellatrice



Ø mm 2-2,5-3 € 25,00 2 017620001
L mm 210
3,5-4-4,5

1763

pinza per graffette tappezzerie auto



1763 € 30,00 1 017630001

1763G/S500

500 graffette per tappezzerie auto



1763G/S500 € 56,00 1 017630105

1765/C24

cassetta di 24 attrezzi per estrazione autoradio



1765/C24 € 161,00 1 017650001

1766

ventosa doppia

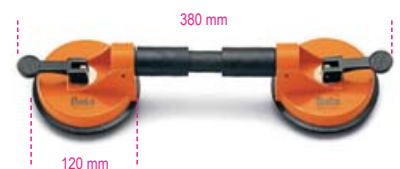

max kg 50 € 101,00 2 017660001

1766A
ventosa singola



120 mm

max
kg
30 € 25,50 2 017660005

1766/8
assortimento di 8 utensili
per cristalli auto



1766/8 € 376,00 1 017660100

1766ER
estrattore per raschiavetri
con impugnatura

permette di rimuovere agevolmente
i raschiavetri senza rischi di danneggiamenti



1766ER € 18,30 1 017660501

1766L
leva per cristalli



75 mm

340 mm

1766L € 42,00 1 017660015

1766LI
leva per inserimento cavo tagliacrystalli

bordi affilati per taglio sigillante



290 mm

1766LI € 14,80 1 017660016

1766I
impugnatura per cavo d'acciaio 1766G

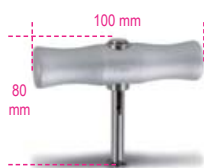

100 mm

80 mm

1766I € 40,50 2 017660020

1766G
cavo d'acciaio per cristalli

sezione quadrata



0,7 mm

50 m € 36,50 1 017660025

1766T
cavo d'acciaio per cristalli

sezione triangolare



0,7 mm

50 m € 42,00 1 017660026

1767A
asta telescopica

• ideata per sostenere cofani e portelloni con pistoni scarichi
• utilizzabile per mantenere i pedali bloccati



L
mm
640 ÷ 1090 € 57,50 1 017670000

1767PMC
portaminuterie magnetico tondo



∅

150 mm

1767PMC € 17,80 1 017670020

1767PMR
portaminuterie magnetico rettangolare

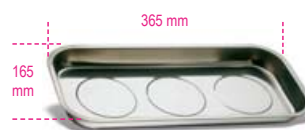

365 mm

165 mm



1767PMR € 36,50 1 017670010

1770
cutter extra piatto
fornito con 2 lame



L A
mm mm
140 9 € 13,90 10 017700001

1770A

cutter 9mm con blocco automatico della lama, fornito con 3 lame

- cursore di sicurezza antiritorno



1770A	L mm	A mm	€	5	10	017700025
	135	9	5,20			

1770RL

10 lame a settori 9 mm per cutter 1770, 1770A e 1770BM



1770RL	€	5	017700010
	4,60		

1770BM

cutter 9 mm, fornito con 6 lame

caricamento automatico della lama



1770BM	L mm	A mm	€	5	10	017700050
	140	9	10,70			

1771

cutter 18 mm fornito con 3 lame



1771	€	5	017710000
	7,90		

1771BM

cutter 18 mm fornito con 6 lame

caricamento automatico della lama



1771BM	L mm	A mm	€	5	10	017710050
	170	18	17,20			

1771HD

cutter 18 mm fornito con 6 lame

- caricamento automatico della lama
- sistema bloccalama a vite



1771HD	L mm	A mm	€	5	017710100
	190	18	19,30		

1771RL

10 lame a settori 18 mm per cutter 1771, 1771BM e 1771HD



1771RL	€	5	017710010
	6,60		

1772M

cutter a lama retrattile di sicurezza fornito con 4 lame

lama con rientro automatico a molla

- corpo in lega pressofusa
- levapunti integrato nel manico



1772M	L mm	A mm	€	5	017720040
	170	18	15,70		

1772R

cutter a lama trapezoidale retrattile, fornito con 5 lame

caricamento automatico della lama



1772R	L mm	A mm	€	5	017720006
	125	18	14,50		

1772H

cutter a lama retrattile di sicurezza, fornito con 2 lame



1772H	L mm	A mm	€	5	017720029
	170	18	15,20		

1772RL/2

10 lame trapezoidali lunghe, in astuccio, per cutter 1772H, 1772M, 1772R, 1774, 1777BMT, 1777T

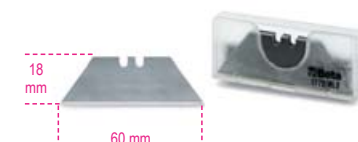

1772RL/2	€	5	017720017
	3,70		

1773A

cutter 25 mm

- sistema bloccalama a ghiera
- lama da 25 mm



1773A	L mm	A mm	€	5	10	017730000
	180	25	15,20			

1773RL

10 lame a settori 25 mm per cutter 1773A



1773RL	€	5	017730015
	14,80		

1774

raschietto multiuso con salvalama di protezione



1774	L mm	L1 mm	€	5	017740001
	155	60	3,50		

1774A

raschietto multiuso con impugnatura bimatereale



1774A	L mm	A mm	€	1	017740011
	300	40	10,90		

1774A/RL

10 lame per raschietto 1774A e 1774S

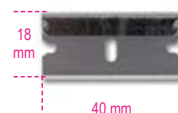

1774A/RL	€	1	017740511
	5,20		

1774S

raschietti per rimozione adesivi



1774S	A mm	L mm	€	1	017740021
	40	100	5,90		

1777BM

coltello a serramanico con gola spellafili
lama in acciaio inossidabile



	L	L1	A	€	5	017770100
	mm	mm	mm			
1777BM	190	80	16	9,90		

1777T

cutter a serramanico con lama trapezoidale
impugnatura in alluminio, fornito con 5 lame



	L	A	L1	€	5	017770030
	mm	mm	mm			
1777T	160	19	65	21,80		

1777BMT

cutter a serramanico con lama trapezoidale
4 profondità regolabili della lama
4; 9.5; 15.5; 21.5 mm
fornito con 3 lame



	L	L1	A	€	5	017770050
	mm	mm	mm			
1777BMT	170	80	19	23,30		

1778AX

coltello a serramanico
lama in acciaio inossidabile seghettata,
impugnatura in alluminio,
con dentello apertura agevolata,
• in astuccio



	L	A	L1	€	5	017780026
	mm	mm	mm			
1778AX	189	26	80	30,00		

1778CM

coltello a serramanico mimetico
lama in acciaio temprato
• in astuccio



	L	A	L1	€	5	017780099
	mm	mm	mm			
1778CM	195	24	80	28,00		

1778D

coltello a serramanico
lama ed impugnatura in acciaio inossidabile
• in astuccio



	L	A	L1	€	5	017780060
	mm	mm	mm			
1778D	180	22	78	29,00		

1778P

coltello a serramanico
lama ed impugnatura in acciaio inossidabile e
alluminio,
con apertura a pulsante
• in astuccio



	L	A	L1	€	5	017780088
	mm	mm	mm			
1778P	193	29	72	32,00		

1778SCL

coltello a serramanico con finitura soft carbon
look
lama in acciaio temprato
• in astuccio



	L	A	L1	€	5	017780089
	mm	mm	mm			
1778SCL	180	22	78	26,00		

1778SOS

coltello soccorso auto
con funzione martello frangicristallo
e tagliacinture di sicurezza
• in astuccio



	L	A	L1	€	5	017780080
	mm	mm	mm			
1778SOS	205	25	85	28,00		

1778U

coltello a serramanico
lama in acciaio temprato
• in astuccio



	L	A	L1	€	5	017780070
	mm	mm	mm			
1778U	195	24	80	27,00		

1778V18

coltello a serramanico
impugnatura in alluminio
• in astuccio



	L	A	L1	€	5	017780018
	mm	mm	mm			
1778V18	195	25	85	26,00		

1778X

coltelli per nautica in acciaio inossidabile
impugnatura in alluminio



	L	L1	A	€	2	017780050
	mm	mm	mm			
1778X	185	85	25	25,00		

1781

forbici a lame lunghe sottili



L	mm	€	Icon	Icon
1781	132	15,30	2	017810001

1783

forbici modello leggero



L	mm	€	Icon	Icon
1783	215	12,70	5	017830021
	240	14,20	5	017830024

1784

forbici modello pesante



L	mm	€	Icon	Icon
1784	175	18,30	2	017840017
	200	24,40	2	017840020
	250	32,50	2	017840025
	300	44,50	2	017840030

1800/100

cuscini sollevatori (max 135 kg)

- sollevare-livellare
- bloccare porte ed ante



A	B	S	€	Icon	Icon
1800	160	150	2=55	48,50	3 018000000

1808

saldatore a doppia potenza con punta acciata 1824 R08



W	V	€	Icon	Icon
1808	20/130	230	1	018080001

1812 150

saldatore istantaneo

CE



W	V	€	Icon	Icon
1812	150	230	89,00	1 018120015

1814M

saldatori a stilo con punta acciata

CE



W	V	€	Icon	Icon
1814M	25	230	50,00	1 018140225
	30	230	53,50	1 018140230
	40	230	58,00	1 018140240

1820

saldatori a stilo

CE



1820	30W	€	Icon	Icon
	L = 210mm	37,50	1	018200003
	60W	42,50	1	018200006
	L = 220mm	60,50	1	018200008
	80W			
	L = 260mm			

1822

saldatori a martello

CE



1822	120	€	Icon	Icon
	120W	92,00	1	018220012
	LxA = 250x125 mm	97,00	1	018220018
	180W	121,00	1	018220032
	LxA = 250x140mm			

1823 60

stazione di saldatura a controllo digitale fornita con saldatore

- Regolazione continua della temperatura da 160°C a 480°C con precisione ±1%.
- Funzione di memoria per salvataggio temperatura selezionata al momento dello spegnimento.
- 3 tasti di selezione rapida (200-300-400°C).

CE



W	€	Icon	Icon
1823	60	356,00	1 018230060

1823R/60

saldatore di ricambio per 1823 60

CE



1823R	60	€	Icon	Icon
		70,50	1	018230066

1824R

punte di ricambio per saldatori



1824R	08	€	Icon	Icon
	1808	26,50	1	018240100
	12	3,60	1	018240301
	1812/150			
	1824R 14-M25	3,60	1	018240152
	1814M/25			
	1824R 14-M30	3,60	1	018240153
	1814M/30			
	1824R 14-M40	3,60	1	018240154
	1814M/40			
	1824R 20	4,70	1	018240302
	1820/30			
	1824R 60	4,70	1	018240303
	1820/60			
	1824R 80	6,90	1	018240304
	1820/80			
	1824R 120-180	56,00	1	018240305
	1822/120 -180			
	1824R 320	71,50	1	018240307
	1822/320			
	1824R ST-60	9,70	1	018240308
	1823-60			

1825B

filo per saldatura a stagno con antiossidante

- filo da 1mm²; 250g
- Sn 99.3%; Cu 0.7%



1825B	€	Icon	Icon
	52,50	1	018250251

1827

saldatore a gas regolabile



1827 € 112,50 1 018270001

1827PC

punte di ricambio coniche per 1827



1827PC 1,6 € 23,50 1 018270501
1827PC 3,2 € 23,50 1 018270502

1827PCL

punta di ricambio a coltello per 1827



1827PCL 2,4 € 23,50 1 018270503

1827PFL

punte di ricambio a fiamma libera per 1827



1827PFL € 23,50 1 018270504

1827/K

saldatore a gas con 7 accessori in valigetta con base morbida di polietilene espanso



- Potenza: da 30 Watt a 125 Watt.
- Temperatura della punta regolabile da 250°C a 500°C.
- Regolatore del flusso di gas.
- Tempo di riscaldamento: 15 secondi dopo l'accensione.
- Il serbatoio contiene gas per 120 minuti di utilizzo continuato.
- Serbatoio trasparente per monitorare il livello di gas.
- Ricaricabile con gas butano.

1827/K € 174,00 1 018270100

1827F

saldatore a gas butano ricaricabile

maxiserbatoio da 35g

- tre ugelli intercambiabili da 550°C; 1000°C e 1300°C
- fornito con cavalletto in valigetta rigida



1827F € 124,00 1 018270200

1830T

pompette per dissaldare con ugello antistatico in materiale plastico (PTFE)



L mm 190 € 13,20 5 018300021

1833L/USB

torcia LED ricaricabile ad alta luminosità in robusto alluminio anodizzato, fino a 1200 Lumen

- cono luminoso regolabile
- 3 intensità luminose
- durata 3.0h
- IP66
- indicazione di batteria scarica sotto il 15%
- ricarica con attacco USB-C
- caricatore non incluso



L mm 240 € 95,00 1 018330054

1833RB-L/USB

batteria di ricambio per 1833L/USB

1833RB-L/USB € 44,00 1 018330975

1833KS/1

torcia LED per ispezioni, in robusto alluminio anodizzato

- 100 lumen
- cono luminoso regolabile
- pila 1xAAA (non inclusa)
- IP66
- durata 5.0h



L mm 92 € 16,50 3 018330000

1833KS/2

torcia LED per ispezioni, in robusto alluminio anodizzato

- 200 lumen
- cono luminoso regolabile
- pile 2xAAA (non incluse)
- IP66
- durata 10.0h



L mm 133 € 18,00 3 018330001

1833S

torcia LED ad alta luminosità in robusto alluminio anodizzato, fino a 500 Lumen

- cono luminoso regolabile
- 2 intensità luminose
- pile 2xAA (non incluse)
- durata 10.0h
- IP66



L mm 150 € 31,50 1 018330002

Beta
Quality Tools

1833M

torcia LED ad alta luminosità
in robusto alluminio anodizzato,
fino a **700 Lumen**

- cono luminoso regolabile
- 2 intensità luminose
- pile 3xAAA (non incluse)
- durata 7.5h
- IP66



L
mm
162 € 39,00 1 018330003

1833L

torcia LED ad alta luminosità
in robusto alluminio anodizzato,
fino a **1100 Lumen**

- cono luminoso regolabile
- 2 intensità luminose
- pile 3xAA (non incluse)
- durata 8.5h
- IP66



L
mm
196 € 64,50 1 018330004

1833XL

torcia LED ad alta luminosità
in robusto alluminio anodizzato,
fino a **1500 Lumen**

- cono luminoso regolabile
- 2 intensità luminose
- pile 3xD (non incluse)
- durata 22.0h
- IP66



L
mm
300 € 81,00 1 018330005

1834RR

torcia LED ricaricabile
con presa accendisigari

- cono luminoso regolabile
- Ricarica con presa accendisigari 10-28V DC
- IP30
- 130 Lumen



1834RR € 43,00 1 018340520

1836A

lampada da testa a LED, con doppia
luminosità e sensore ON/OFF contactless

- 120/65 lumen
- IP54
- pile : 3xAAA include



1836A € 43,50 1 018360050

1836B

lampada da testa ricaricabile a LED,
con doppia luminosità e sensore ON/OFF

- Sensore ON/OFF contactless
- 250 Lumen
- Autonomia : 3-6 h
- IP65



1836B € 106,00 1 018360200

1837C

faretti ricaricabili a LED da cantiere

- 3 intensità luminose
- carica batterie:
input: 100-240V AC - 50/60Hz;
output: 15V 1.5A
- tempo di ricarica: 4 ore
- indicatore di carica a 3 LED
- orientabile a 180°
- IP65
- IK07



LxHxI mm	Lm	h	€	
220x225x70	2100	2.5	154,00	1 018370210
	1000	5.0		
	500	9.0		
266x236.6x59	4300	1.5	225,00	1 018370430
	2100	3.0		
	1100	6.0		

1837F

lampada magnetica snodata con LED ad alta
luminosità,
in robusto alluminio anodizzato,
fino a **500 Lumen**

- cono luminoso regolabile
- 2 intensità luminose
- pile 3xAA (non incluse)
- durata 14.5h
- indicatore di carica
- IP66



L
mm
460 € 70,00 1 018370050

1837F/USB

lampada **ricaricabile** magnetica snodata con
LED ad alta luminosità,
in robusto alluminio anodizzato,
fino a **600 Lumen**

- cono luminoso regolabile
- 2 intensità luminose
- durata 10.0h
- ricarica con attacco USB-C
- IP66



L
mm
460 € 103,00 1 018370060

1837RB-F/USB

batteria di ricambio per 1837F/USB

1837RB-F/USB € 31,00 1 018370960

1837M

faretto ricaricabile a LED **COLOUR MATCH**, per controllo colore, elevato indice di resa cromatica (**CRI 96+**), **fino a 2.000 Lumen**

- 3 intensità luminose: 500/1.000/2.000Lumen
- CRI (indice di resa cromatica): 96+
- CCT (temperatura colore): 2700K/ 3500K/ 4500K/ 5500K/ 6500K
- carica batterie: input: 100-240V AC - 50/60Hz; output: 15V 1.5A
- connettore di ricarica a sgancio rapido
- tempo di ricarica: 3.5 ore
- durata: 8/4/2 h
- indicatore di carica
- pulsante e led indicatore di temperatura colore
- pulsante e led indicatore di intensità luminosa
- orientabile a 180°
- IP65
- IK07



LxHxI mm	Lm	h	€		
220x225x70	500	8.0	240,00	1	018370450
	1000	4.0			
	2000	2.0			

1837S

treppiede telescopico per supporto faro da cantiere

- in metallo
- altezza variabile 70÷170 cm
- compatibile con 1837C e 1838FLASH



h cm	€		
70÷170	49,50	1	018370500

1838/11LED

lampada ricaricabile con LED ad altissima luminosità

- batteria ai polimeri di litio
- corpo compatto in gomma antiscivolo
- vetrino frontale facilmente sostituibile
- gancio orientabile
- con stazione di ricarica 110-230Vac
- 320 Lumen
- con led in testa per illuminazione multidirezionale



1838/11LED	€		
	135,00	1	018380111

1838RA/10-11LED

alimentatori di ricambio per 1838/10LED e 1838/11LED

1838RA/10-11LED	€		
	29,00	1	018380903

1838RB/10LED

batteria di ricambio per 1838/10LED e 1838/11LED

1838RB/10LED	€		
	46,00	1	018380902

1838RR/11LED

basi di ricarica per 1838/11LED

1838RR/11LED	€		
	30,00	1	018380914

1838RV/11LED

vetrino paragraffi di ricambio per lampada 1838/11LED

1838RV/11LED	€		
	4,10	2	018380905

1838COB

lampada a LED portatile ricaricabile

- appendibile, con corpo in gomma antiscivolo e antiurto
- batteria ai polimeri di Litio
- 100/200 lumen; SPOT 75 lumen



1838COB	€		
	76,00	1	018380010

1838P

lampada ricaricabile a penna, con doppia emissione luminosa: a lampada o a torcia

- Corpo compatto in gomma antiscivolo
- 75/150 Lumen
- Gancio da taschino
- Base magnetica orientabile a 180 gradi
- Fornita con cavo di ricarica USB/jack 3.5mm
- Autonomia: 2-4 ore
- IP65



1838P	€		
	65,50	1	018380005

1838FLASH

faretto ricaricabile ultracompatto, studiato per offrire la migliore soluzione possibile in ogni utilizzo.

ILLUMINAZIONE ABBONDANTE E SEMPRE PRONTA: con una capacità illuminante massima di 720 lumen e la possibilità di lavorare a batteria o a cavo è sempre pronto all'uso

POSIZIONABILE OVUNQUE:
-su piani: grazie ai piedini di gomma e all'attacco da 1/4" per cavalletto (attacco standard tipo macchina fotografica)
-su strutture metalliche: grazie al magnete svitabile e al gancio orientabile a 360°

COMPATTO: con soli 85x100x155 mm di ingombro può essere comodamente alloggiato nella borsa degli attrezzi ed utilizzato anche in spazi ristretti.

ROBUSTO: studiato per resistere alle sollecitazioni meccaniche più severe.

- 720 Lumen



1838FLASH	€		
	274,00	1	018380300

1838RB/FLASH

batteria di ricambio per 1838FLASH

1838RB/FLASH	€		
	60,00	1	018380930



1838SL

lampada ultrasottile con LED ad altissima luminosità.

Per lavori in spazi ristretti

- alimentazione 12V con spina accendisigari e morsetti per batteria
- cavo da 2,5 m
- spessore 6mm
- 345 Lumen

CE



1838SL € 58,50 1 018380101

1838SLIM

lampada sottile a 3 LED snodata ricaricabile

- 3 emissioni luminose
- frontale: 100/200 lumen/ posteriore: 180 lumen/ spot (testa): 80 lumen
- base magnetica
- tempo di ricarica: 2.5h
- autonomia: 2-4h/ spot 3h

CE



1838SLIM L 307 mm, I 17 mm, S 29 mm € 60,00 1 018380221

1838S

lampada snodata ricaricabile a LED

- orientabile a 180°
- doppia emissione luminosa, frontale e spot (testa)
- 700 lumen / spot 200 lumen
- corpo in gomma antiscivolo
- doppio gancio orientabile
- magneti su base e retro
- fornita con caricatore 100-240V / 50-60Hz
- tempo di ricarica: 4h
- autonomia: 2-7.5h

CE



1838S L 260 mm, I 52 mm, S 38 mm € 71,00 1 018380122

1838UV

lampada ricaricabile UV + luce bianca ideale per la ricerca di perdite

- Corpo compatto in gomma antiscivolo
- Con caricatore 100-240Vac / 50-60Hz
- 150 lumen / UV

CE



1838UV € 129,00 1 018380150

1839/R1

trasformatore con uscita USB, ricambio per 1834L/USB, 1836B, 1837/USB, 1838COB, 1838P, 1838SLR, 1838SN, 1838UV

IN: 100-240Vac / 50-60Hz
USB OUT: 5Vdc / 1A

1839/R1 € 19,50 1 018390501

1839/R2

cavo USB/jack 3.5mm, ricambio per 1836B, 1838P, 1838COB, 1838SLR, 1838SN, 1838UV

1839/R2 € 7,50 1 018390502

1839/R4

cavo USB/USB-C, ricambio per 1833L/USB, 1833F/USB, 1838SLIM, 1838S

1839/R4 € 6,60 1 018390504

1840BM

portlampada portatile per lampada con attacco E27 alimentazione 230V

- Lampada esclusa

CE



1840BM V 230, W 60, L 420 mm € 57,50 1 018400101

1842LED/BM

lampada con LED ad altissima luminosità, 100- 240 Vac

- cavo da 10 m
- corpo compatto in gomma antiscivolo
- vetrino frontale facilmente sostituibile
- gancio orientabile
- 340 Lumen
- con LED in testa per illuminazione multidirezionale

CE



1842LED/BM € 112,00 1 018420301

1842LED/ABM

lampada con LED ad altissima luminosità, 12-24 V AC/DC

- cavo da 10 m
- corpo compatto in gomma antiscivolo
- vetrino frontale facilmente sostituibile
- gancio orientabile
- 340 Lumen
- con LED in testa per illuminazione multidirezionale

CE



1842LED/ABM € 105,00 1 018420311

1843BM

avvolgitore automatico completo di portlampada 230 Vac con attacco E27 e gabbia in acciaio

- Lampadina esclusa
- Max 60W

CE



1843BM € 295,00 1 018430101

1843R/BM

portalamпада di ricambio per avvolgitore, con attacco lampada E27

- Lampadina esclusa

CE



IP20

1843R/BM € 44,00 1 018430131

1846LED/BM

avvolgitore automatico completo di lampada a LED, 100-240Vac

- con trasformatore di sicurezza 230/12V

CE



IP42
IP65

1846LED/BM € 336,00 1 018460301

1846LED/ABM

avvolgitore automatico completo di lampada a LED alimentazione 12-24V AC/DC

- Max 25W

CE



IP42
IP65

1846LED/ABM € 325,00 1 018460311

1846R-LED/BM

lampade di ricambio a LED 12-24V - AC-DC



1846LED/BM R € 76,50 1 018460331

1848

avvolgitore automatico con presa Schuko

- cavo in gomma antisciacchiamento H07 - 3x1.5 mm² - 15m
- Max 1600 W a cavo svolto
- Max 1200 W a cavo avvolto
- con protezione termica

CE



IP42

L=15 m



1848 € 302,00 1 018480015

1850B

pistola termica 2 velocità

- Pos. I 240 l/min 300°C
- Pos. II 450 l/min 500°C

CE



1850B L mm 240 H mm 190 € 120,00 1 018500011

1850C

pistola termica con regolazione elettronica

- Pos. I 150-250 l/min 50°C
- Pos. II 150-500 l/min 50-650°C

- Display digitale.
- Pulsanti regolazione temperatura e portata del flusso.
- 4 programmi memorizzati in origine e possibilità di personalizzazioni

- Prog 1 250°C ca. 350 l/min
- Prog 2 350°C ca. 400 l/min
- Prog 3 450°C ca. 500 l/min
- Prog 4 550°C ca. 400 l/min

CE



L=2,4 m



1850C L mm 255 H mm 210 € 305,00 1 018500015

1850U...

ugelli per 1850B e 1850C

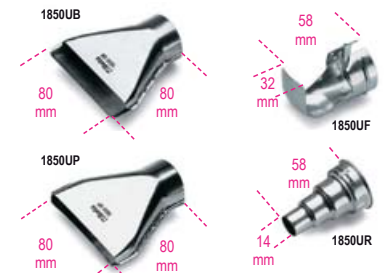

1850UB	1850 B-C	€ 20,80	1	018500100
1850UF	B-C	€ 22,80	1	018500101
1850UP	B-C	€ 20,80	1	018500102
1850UR	C	€ 19,80	1	018500103

1851VK

pistola per colla a caldo con 12 stick di colla termofusibile in valigetta Ø 11 e 12 mm

CE



1851VK € 43,50 1 018510058

320x250x50 mm

1851VK-12C

12 stick di colla termofusibile

Ø 11 mm



1851VK-12C € 11,00 1 018510062

1851VK-12V

12 stick di colla termofusibile per superfici verniciate Ø 11 mm



1851VK-12V € 11,00 1 018510072

1852R1750

riscaldatore ad induzione portatile

CE



- riscalda e sblocca bulloni, dadi, mozzi e cuscinetti particolarmente bloccati senza l'utilizzo di fiamme
- permette di scaldare qualsiasi tipo di metallo ferromagnetico

Dotazione:

- due serpentine frontali con diametro 19 e 26 mm per sblocco dadi
- una serpentina piatta per scaldare le superfici
- una serpentina flessibile lunga 800 mm
- fornito in valigetta di plastica

Dati tecnici:

- tensione di ingresso: 230V AC, 50/60 Hz
- corrente di ingresso: max. 7,5A
- potenza: max. 1.75 kW

VANTAGGI

Risparmio di tempo: riscaldamento veloce e con grande precisione

Sicurezza anti incendio: non genera fiamme, massima sicurezza per l'operatore

Praticità: utilizzabile con una sola mano e serpentine facilmente intercambiabili

CAMPI DI APPLICAZIONE

Automotive
Manutenzione industriale
Industria aeronautica
Industria navale
Industria petrolchimica

1852R1750 1.230,00 € 1 018520175

480x370x130 mm - 4,5 kg

1852S-L

serpentine laterali



	Ø mm	M	L mm	€	1	018520501
1852S-L 19	19	M6	220	37,50	1	018520501
1852S-L 20	20	M8	220	37,50	1	018520502
1852S-L 23	23	M10	220	37,50	1	018520503
1852S-L 26	26	M12	220	37,50	1	018520504
1852S-L 32	32	M16	220	37,50	1	018520505
1852S-L 38	38	M20	220	43,00	1	018520506
1852S-L 45	45	M22	220	47,00	1	018520507



1852S-F

serpentina frontale



	Ø mm	M	L mm	€	1	018520508
1852S-F 19	19	M6	220	37,50	1	018520508
1852S-F 20	20	M8	220	37,50	1	018520509
1852S-F 23	23	M10	220	37,50	1	018520510
1852S-F 26	26	M12	220	37,50	1	018520511
1852S-F 32	32	M16	220	37,50	1	018520512
1852S-F 38	38	M20	220	43,00	1	018520513
1852S-F 45	45	M22	220	46,50	1	018520514

1852S-FLESS

serpentina flessibile



1852S-FL 800	70,00 €	1	018520515
1852S-FL 1000	89,00 €	1	018520517
1852S-FL 1500	106,00 €	1	018520518

1852 S-PIATTE

serpentina piatta



1852S-PIATTE	43,00 €	1	018520516
--------------	---------	---	-----------

1860 140A

saldatrice ad inverter con uscita corrente continua (DC) per saldature ad elettrodo MMA e TIG su acciaio.
compatta e facile da trasportare

funzioni arc force, hotstart, anti-sticking, protezione termostatica

Corrente di regolazione: 5÷140A
Alimentazione: 1x230V

Fattore di utilizzo :
25% - 140 A
60% - 100 A
100% - 90 A
Fusibile ritardato: 16 A
Protezione: IP23S
Elettrodi utilizzabili: Ø 1,5- 4mm rutilici, basici, inox, ghisa, ecc. fornito con cavi da 16mm²



1860 140A	619,00 €	1	018600004
-----------	----------	---	-----------

1860 160A

saldatrice ad inverter con uscita corrente continua (DC) per saldature ad elettrodo MMA eTIG su acciaio.
compatta e facile da trasportare

funzioni arcforce, hotstart, anti-sticking, protezione termostatica

corrente di regolazione: 5÷160A
alimentazione: 1x230V

fattore di utilizzo (40°C) :

30% - 160 A
60% - 130 A
100% - 110 A

fusibile ritardato: 25 A

protezione: IP23S

elettrodi utilizzabili: Ø 1.5 - 4mm rutilici, basici, inox, ghisa, ecc. fornito concavi da 25mm²



1860 160A	749,00 €	1	018600006
-----------	----------	---	-----------

1860RC

cavi di ricambio per saldatrici ad inverter 1860

lunghezza cavo pinza portaelettrodo: 2.5m
lunghezza cavo massa: 1.8m



1860RC/140A	69,00 €	1	018600604
1860RC/160A	88,00 €	1	018600606

1860EI

squadra magnetica 90°, per angoli interni ed esterni.
ideale per bloccare particolari tubolari o piatti
18Kg di forza magnetica
con smussi per angoli da 30 e 60°
con foro esagonale per facilitare il distacco del magnete dal metallo



1860EI	29,00 €	1	018600290
--------	---------	---	-----------



1860RG

squadra magnetica regolabile 30°÷270°

ideale per bloccare particolari tubolari o piatti
15Kg di forza magnetica
chiave esagonale in dotazione per bloccaggio regolazione angolo
perno in dotazione per bloccaggio regolazione a 30°-45°-90°/270°-180°
con foro esagonale per facilitare il distacco del magnete dal metallo



1860RG L mm 155 S mm 35 € 46,50 1 018600255

1860SQ

squadra magnetica 45°/90°

ideale per bloccare particolari tubolari o piatti
25Kg di forza magnetica
non necessita batteria, effetto ON/OFF ottenuto con l'inclinazione dei magneti interni
pulizia da trucioli agevolata coi magneti in posizione OFF

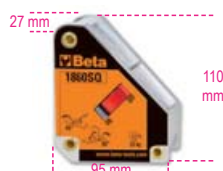

1860SQ € 69,50 1 018600210

7041LCD/4S

maschera LCD ad oscuramento automatico, per saldatura ad elettrodo; MIG/MAG; TIG e plasma.

4 sensori

con filtro TRUE COLOR

alimentazione a celle solari e batterie al litio per una durata eccezionale del filtro LCD

- area di visuale 98x80 mm
- tonalità di oscuramento variabile 5÷8,5/ 9-13 con regolazione interna
- protezione UV/IR: DIN16
- tempo d'oscuramento 1/25000 s
- tempo di rischiaramento 0.1-2.0s
- sensibilità e ritardo dell'oscuramento regolabili
- accensione e spegnimento automatici
- funzione di smerigliatura
- indicatore livello basso batteria
- design ergonomico, leggera e ben bilanciata
- con ghiera regolabile



CE



7041LCD/4S € 225,00 1 070410001

7041LCD/4S-VE

vetrino paragraffi esterno per 7041LCD/4S

7041LCD/4S-VE € 5,50 2 070410101

7041LCD/4S-VI

vetrino interno per 7041LCD/4S

7041LCD/4S-VI € 2,80 2 070410102

7042LCD

maschera LCD ad oscuramento automatico, per saldatura ad elettrodo; MIG/MAG; TIG e plasma.

alimentazione a celle solari e batterie al litio per una durata eccezionale del filtro LCD

- area di visuale 98x43 mm
- tonalità di oscuramento DIN 9-13 con regolazione esterna
- protezione UV/IR
- tempo d'oscuramento 1/25000 s
- tempo di rischiaramento 0.25-1s
- sensibilità e ritardo dell'oscuramento regolabili
- accensione e spegnimento automatici
- funzione di smerigliatura
- forma ottimizzata per agevolare la respirazione a schermo abbassato



CE



7042LCD € 158,50 1 070420001

7042LCD/RV

vetrino paragraffi esterno per 7042LCD, 7043

7042LCD/RV € 2,50 2 070420101

7042LCD/RV-INT

vetrino interno per 7042LCD, 7043

7042LCD/RV-INT € 2,20 2 070420102



7043

maschera LCD ad oscuramento automatico, per saldatura ad elettrodo, MIG/MAG, TIG e plasma.

alimentazione a celle solari.

- area di visuale 92x43 mm
- tonalità di oscuramento DIN 9-13 con regolazione esterna
- protezione UV/IR
- tempo d'oscuramento 1/1000 s
- tempo di rischiaramento 0.1-1.0 s
- ritardo dell'oscuramento regolabile
- accensione e spegnimento automatici
- funzione di smerigliatura
- forma ottimizzata per agevolare la respirazione a schermo abbassato



CE



7043 € 92,00 1 070430001

1870

aspiratore 20 litri per solidi e liquidi

- motore by-pass monostadio
- tensione 230/240 V
- frequenza 50/60 Hz
- potenza Max 1200 W
- portata d'aria l/sec. 58
- depressione Max 190 mbar
- capienza Max bidone 20 l in PP antistatico
- emissioni acustiche <70 dB(A)
- lunghezza cavo 5 m
- carrello porta accessori

ACCESSORI IN DOTAZIONE Ø 36 mm

- 1 tubo corrugato completo di impugnatura ergonomica
- 2 tubi rigidi di prolunga
- 1 spazzola multiuso per pavimenti e liquidi
- 1 bocchetta a lancia

SISTEMI FILTRANTI

- 1 cartuccia filtro aria superficiale 1900 cm² - 12 micron nom.
- 1 filtro anti-schiuma PPI 45/PPI 30

CE



IPX4

1870 € 186,00 1 018700020

1871M

aspiratore 35 litri per solidi e liquidi con prese di servio corrente ed aria compressa classe certificata "M"

- pulizia automatica del filtro
- motore by-pass bistadio
- tensione 230/240 V
- potenza Max 1200 W
- potenza Max presa di servizio 2000 W
- pressione Max attacco utensile pneumatico 15 bar
- portata d'aria 60 l/sec.
- depressione Max 220 mbar
- capienza Max bidone 35 l in PE-HD antistatico
- emissioni acustiche <68 dB(A)
- lunghezza cavo 7 m

ACCESSORI IN DOTAZIONE

- 1 tubo corrugato completo di impugnatura ergonomica
- 2 tubi di prolunga in plastica
- 1 telaio spazzola combinato
- 1 inserto con gomme raccogli liquidi
- 1 bocchetta a lancia
- 1 raccordo in gomma per collegamento ad utensili Ø int. 26 mm
- 6 bocca tubo aria con tubo aspirazione

SISTEMI FILTRANTI

- sacco in carta IFA cat "M"
- cartuccia filtro IFA cat "M"
- filtro anti-schiuma PPI 45/PPI 30

CE



1871M € 1.135,00 1 018710035

1871M/AS

aspiratore 35 litri per solidi e liquidi con prese di servio corrente ed aria compressa classe certificata "M"

- pulizia automatica del filtro
- motore by-pass bistadio
- tensione 230/240 V
- potenza Max 1200 W
- potenza Max presa di servizio 2000 W
- pressione Max attacco utensile pneumatico 15 bar
- portata d'aria 60 l/sec.
- depressione Max 220 mbar
- capienza Max bidone 35 l in PE-HD antistatico
- emissioni acustiche <68 dB(A)
- lunghezza cavo 7 m

ACCESSORI IN DOTAZIONE

- 1 tubo corrugato

CE



1871M/AS € 1.000,00 1 018710135

1872L

aspiratore 35 litri per solidi e liquidi classe certificata "L"

- motore by-pass bistadio
- tensione 230/240 V
- frequenza 50/60 Hz
- potenza Max 1100 W
- portata d'aria l/sec. 55
- depressione Max 220 mbar
- capienza Max bidone 35 l in PE-HD antistatico
- emissioni acustiche <68 dB(A)
- lunghezza cavo 6 m

ACCESSORI IN DOTAZIONE Ø 36 mm

- 1 tubo corrugato completo di impugnatura ergonomica
- 2 tubi di prolunga in plastica
- 1 telaio spazzola combinata
- 1 inserto con gomme raccogli liquidi

1 bocchetta a lancia

SISTEMI FILTRANTI

- 1 sacco in tessuto non tessuto classe di filtraggio "L"
- 1 cartuccia filtro classificata IFA classe "L"
- 1 filtro anti-schiuma PPI 45/PPI 30
- 2 post-filtri in PET accoppiato a PP

CE



IPX4

1872L € 405,00 1 018720135

1873

aspiratore 30 litri per solidi e liquidi, bidone in acciaio INOX

- motore by-pass bistadio • tensione 230/240 V
- frequenza 50/60 Hz • potenza Max 1100 W
- portata d'aria l/sec. 55
- depressione Max 220 mbar
- capienza Max bidone 30 l in acciaio Inox
- emissioni acustiche <61 dB(A)
- lunghezza cavo 6 m
- carrello porta accessori

ACCESSORI IN DOTAZIONE Ø 45mm

- 1 tubo corrugato completo di impugnatura ergonomica
- 2 tubi di prolunga in acciaio inox
- 1 telaio spazzola industriale
- 1 inserto industriale moquette
- 1 inserto industriale con gomme raccogli liquidi
- 1 bocchetta a lancia

SISTEMI FILTRANTI

- 1 sacco in carta filtro
- 1 cartuccia filtro superficiale 1900 cm² 12 micron nom.
- 1 filtro anti-schiuma PPI 45/PPI 30

CE



1873 30 € 540,00 1 018730030

1874

aspiratore 50 litri per solidi e liquidi, bidone in acciaio INOX

- motore by-pass bistadio
- tensione 230/240 V
- frequenza 50/60 Hz
- potenza Max 1350 W
- portata d'aria l/sec. 55
- depressione Max 240 mbar
- capienza Max bidone 50 l in acciaio Inox
- emissioni acustiche <63 dB(A)
- lunghezza cavo 6 m
- carrello porta accessori

ACCESSORI IN DOTAZIONE Ø 45mm

- 1 tubo corrugato completo di impugnatura ergonomica
- 2 tubi di prolunga in acciaio inox
- 1 telaio spazzola industriale
- 1 inserto industriale moquette
- 1 inserto industriale con gomme raccogli liquidi
- 1 bocchetta a lancia

SISTEMI FILTRANTI

- 1 sacco filtro
- 1 cartuccia filtro superficiale 5200 cm² 12 micron nom.
- 1 filtro anti-schiuma PPI 45/PPI 30

CE



1874 50 € 682,00 1 018740050

1870-20/5S

5 sacchi in carta orizzontali per 1870



1870 20/5S € 44,00 1 018700021

1870-72 /FC

filtro a cartuccia 1900 cm² 12 micron nominali per 1870 - 1872 - 1873



1870-72 /FC € 37,50 1 018700026

1870-72/FL

filtro per aspirazione liquidi
per 1870 - 1871M - 1872 - 1872L - 1873 -
1874



1870 72/FL € 13,80 1 018700027

1872L 35/FC

filtro a cartuccia classe "L"
per 1872L



1872L 35/FC € 46,00 1 018720144

1872L 35/5S

5 sacchi in tessuto non tessuto classe "L"
per 1872L



1872L 35/5S € 69,00 1 018720136

1873-30/5S

5 sacchi in carta verticali per 1873



1873 30/5S € 44,00 1 018730031

1874-50/5S

5 sacchi verticale per 1874



1874 50/5S € 55,00 1 018740051

1874-50/FC

filtro a cartuccia 5200 cm² 12 micron nominali
per 1874



1874 50/FC € 45,50 1 018740056

1877

recuperatore olio esausto carrellato
con serbatoio da 90 l

- indicatore di livello
- coppa di grande diametro con griglia scolafiltro capacità 12 l
- svuotamento pneumatico del serbatoio con tubo da 1,8 m
- vaschetta portautensili

CE



1877 € 585,00 1 018770008

1877A

recuperatore/aspiratore olio esausto, carrellato
con serbatoio da 90 l e precamera

- indicatore di livello
- coppa di grande diametro con griglia scolafiltro capacità 12 l
- precamera trasparente capacità 9,5 l
- tubo aspirazione da 1,8 m
- svuotamento pneumatico del serbatoio con tubo da 1,8 m
- vaschetta portautensili

In dotazione:
• 1 sonda rigida Ø 5x700 mm
• 1 sonda flessibile Ø 5x700 mm
• 1 sonda rigida Ø 6x600 mm
• 1 sonda flessibile Ø 6x700 mm
• 1 sonda flessibile Ø 7x700 mm
• 1 sonda flessibile Ø 8x700 mm
• adattatori per VW, BMW, CITROËN

CE



1877A € 1.032,00 1 018770080

1878 2

vaschetta per recupero liquidi

- capacità massima 2 l
- particolarmente indicata per la sostituzione olio sugli scooter



1878 2 l H mm € 12,00 1 018780002

1878 3

vaschetta per recupero olio
mozzi truck
scarico dell'olio con salvagocia



1878 3 l H mm € 18,00 1 018780003

1878 4

vaschetta per recupero liquidi
trasportabile

- indicata per moto
- capacità massima 4 l
- limita gli schizzi



1878 4 l H mm € 25,00 1 018780004

1878 8

vaschetta per recupero liquidi

- altezza idonea per moto
- capacità massima 8 l



1878 8 l H mm € 13,50 1 018780008

1878 11

vaschetta per recupero liquidi

- capacità Massima 11 l
- tappo scarico liquidi
- paratia interna per evitare la fuoriuscita dei liquidi durante il trasporto



1878 11 | 11 € 30,50 1 018780011

1878 30

vasca per recupero liquidi

- capacità Massima 30 l
- griglia anti schizzi
- dotata di 4 ruote pivotanti

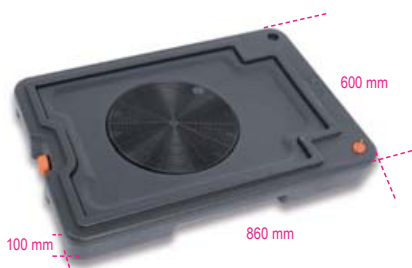

1878 30 | 30 € 117,00 1 018780030

1879

aspiratore liquidi manuale e pneumatico da 9,5 Litri



1879 € 252,00 1 018790001

1879 6

aspiratore liquidi manuale da 6 litri



1879 6 € 184,00 1 018790000

1879R/K4

kit di 4 tubi di ricambio per aspiratore liquidi 1879



1879R/K4 € 48,50 1 018790504

1879/FUEL

aspiratore liquidi manuale da 6 litri utilizzabile per idrocarburi



1879/FUEL | 6 € 110,00 1 018790010

1880

pompa manuale per fusti olio

- per olio
- non usare con liquidi a base acquosa, solventi acidi, gasolio, benzina e simili
- completa di attacco fusto, tubo telescopico e beccuccio di mandata



1880 gr 240 € 47,50 1 018800001

1880ADB

pompa rotativa per AdBlue®

- 5 litri erogati ogni venti rotazioni
- prolunghe per fusti fino a 1,20 m
- 1 attacco per fusti passo fine
- 1 attacco per fusti passo grosso



1880ADB € 111,00 1 018800101

1881

pompa pneumatica per fusti olio rapporto 3:1

- pressione di lavoro da 6 a 8 bar
- consumo aria 230 l/min
- per olio
- non usare con liquidi a base acquosa, solventi acidi, gasolio, benzina e simili
- completa di attacco fusto e tubo telescopico



1881 l/min 14 € 405,00 1 018810001

1882

pistola olio con estremità flessibile e salvagocia automatico

- attacco 1/2"
- portata massima 35 l/min
- pressione massima di esercizio 100 bar
- possibilità di bloccare la leva di erogazione



1882 € 122,00 1 018820010

1883

contalibri digitale per olio

- attacco 1/2"
- rivestimento in gomma anti urto
- pila 1 CR2 (inclusa)
- portata Max: 0÷35 l/min (0÷9 gal/min)
- pressione Max: 50 bar (750 psi)
- viscosità: 8÷5000 mPas
- tolleranza: ±0,5%

CE



1883 € 185,00 1 018830035

1883NC

niplex maschio-maschio 1/2 per unire art. 1882 e 1883



1883NC € 11,50 1 018830135

1884

attrezzo per l'inserimento di olio nei cambi manuali, automatici e nei differenziali

con 12 adattatori per la connessione diretta



1884 € 400,00 1 018840010

AT-101	FORD
AT-102	UNIVERSAL (Bmw, Honda, Nissan...)
AT-103	VW-AUDI
AT-104	VW-AUDI-PORSCHE
AT-105	VW-AUDI-MINI COOPER
AT-106	MERCEDES
AT-107	DSG
AT-108	VW-AUDI CVT
AT-109	VOLVO
AT-110	TOYOTA-LEXUS
AT-111	SKODA
AT-112	VW Passat/Tiguan <2007

1884/C12

cassetta di 12 adattatori per 1884

• inclusa nel 1884



1884/C12 € 148,00 1 018840100

1889

base in acciaio per movimentazione e stoccaggio di 2 fusti da 200 l

- verniciata completamente a caldo a polvere epossidica
- facilmente trasportabile con carrello elevatore a forche o transpallet
- supporto non sovrapponibile

CE

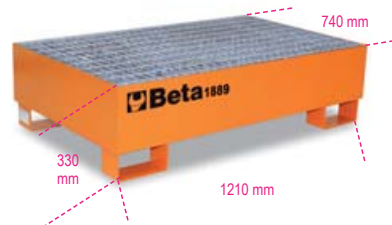

1889 € 665,00 1 018890200

1889CF

chiave universale per apertura fusti

- 1 esagono femmina Ø 38 mm
- 1 profilo a 4 settori Ø 42 mm
- 1 lama 17x7 mm



L mm 270 € 28,50 1 018890010

1885

stazione per la manutenzione del cambio automatico

Permette di effettuare in totale sicurezza, con una procedura semplice e guidata, l'intero ciclo di lavaggio e sostituzione olio in tutte le trasmissioni automatiche.

Previene il danneggiamento derivante dall'usura dell'olio contenuto nel cambio automatico, prevenendo in modo pratico e veloce malfunzionamenti caratteristici come: rumorosità eccessiva del cambio, marce bloccate, bruschi innesti delle marce, allungamento dei tempi di cambiata



CE



CARATTERISTICHE FUNZIONALI

Funzionamento automatico
Procedura guidata passo passo con banca dati integrata
Compensazione della quantità dell'olio immesso con la stessa quantità di olio esausto, garantendo la presenza costante della corretta quantità di olio nell'impianto
Flussimetro per controllo visivo della qualità dell'olio
Stampa di ogni operazione effettuata
Cassetto con adattatori per i cambi più diffusi in modulo morbido

CARATTERISTICHE AUTOMATICHE

Immissione solvente (facoltativo)
Lavaggio impianto cambio
Svuotamento olio coppa
Svuotamento olio convertitore
Immissione olio convertitore

CARATTERISTICHE TECNICHE

Alimentazione: 220 V 50 Hz
Visori olio retroilluminati con n.2 LED luce bianca
Bilance elettroniche n. 2
Bilance elettroniche risoluzione +/- 10 g
Scheda elettronica con display grafico retroilluminato

1885 € 7.090,00 1 018850010

1885/C1

kit raccordi cambio automatico per 1885 (non inclusi in 1885)

il kit include:

- 1885/C1-R1 raccordi cambio Land Rover Freelander
- 1885/C1-R2 raccordo cambio DP0
- 1885/C1-R3 raccordo cambio ZF 9HP
- 1885/C1-R4 asta di livello cambio ZF 9HP
- 1885/C1-R5 asta di livello cambio Mercedes
- 1885/C1-R6 raccordi cambio AISIN TG82
- 1885/C1-R7 raccordi cambio AISIN TG81
- 1885/C1-R8 raccordi cambio Renault-Nissan



1885/C1 € 609,00 1 018850110

1885/C1-R1

raccordi cambio Land Rover Freelander per 1885

Ic01430



1885/C1-R1 € 53,00 1 018850111

1885/C1-R2

raccordo cambio DP0 per 1885

Ic0990



1885/C1-R2 € 92,00 1 018850112

1885/C1-R3

raccordi cambio ZF 9HP per 1885

Ic0992



1885/C1-R3 € 102,50 1 018850113

1885/C1-R4

asta di livello cambio ZF 9HP per 1885

Ic0192



1885/C1-R4 € 57,50 1 018850114

1885/C1-R5

asta di livello cambio Mercedes per 1885

K-A-M



1885/C1-R5 € 95,00 1 018850115

1885/C1-R6

raccordi cambio AISIN TG82 per 1885

lc01820



1885/C1-R6 € 102,00 1 018850116

1885/C1-R7

raccordi cambio AISIN TG81 per 1885

lc0150



1885/C1-R7 € 102,00 1 018850117

1885/C1-R8

raccordi cambio Renault-Nissan per 1885

lc02150



1885/C1-R8 € 102,00 1 018850118

1885/C2

kit raccordi cambio automatico per 1885 (non inclusi in 1885)

il kit include:

- 1885/C2-R1 raccordi cambio Audi 8HP
- 1885/C2-R2 raccordi cambio ZF 9HP senza scambiatore
- 1885/C2-R3 raccordo cambio Audi 0KC
- 1885/C2-R4 raccordi cambio AG4-ZF 4HP
- 1885/C2-R5 raccordi cambio FIAT
- 1885/C2-R6 raccordi cambio Audi Q5-Q7
- 1885/C2-R7 raccordo Audi cambio 0B5



1885/C2 € 496,00 1 018850120

1885/C2-R1

raccordi cambio Audi 8HP per 1885

lc0993



1885/C2-R1 € 99,50 1 018850121

1885/C2-R2

raccordi cambio ZF 9HP senza scambiatore per 1885
lc0990



1885/C2-R2 € 65,00 1 018850122

1885/C2-R3

raccordo cambio Audi 0KC per 1885

lc02020



1885/C2-R3 € 102,00 1 018850123

1885/C2-R4

raccordi cambio AG4-ZF 4HP per 1885

lc0750



1885/C2-R4 € 88,00 1 018850124

1885/C2-R5

raccordi cambio FIAT per 1885

lc0061



1885/C2-R5 € 38,50 1 018850125

1885/C2-R6

raccordi cambio Audi Q5-Q7 per 1885

lc0680



1885/C2-R6 € 95,00 1 018850126

1885/C2-R7

raccordo cambio Audi 0B5 per 1885

lc01720



1885/C2-R7 € 57,50 1 018850127

1885/C3

kit raccordi cambio automatico per 1885 (non inclusi in 1885)

il kit include:

- 1885/C3-R1 raccordo cambio DSG Mercedes
- 1885/C3-R2 raccordo cambio POWERSHIFT
- 1885/C3-R3 raccordi cambio Toyota IQ
- 1885/C3-R4 raccordi cambio Mazda
- 1885/C3-R5 raccordi cambio Renault Laguna-Esp
- 1885/C3-R6 raccordi cambio Nissan Juke
- 1885/C3-R7 raccordi cambio AISIN TF71 FV
- 1885/C3-R8 raccordi cambio AISIN TF71 FP
- 1885/C3-R9 raccordi cambio AISIN TF71 FO
- 1885/C3-R10 raccordi cambio AISIN TF71 FS



1885/C3 € 875,00 1 018850130

1885/C3-R1

raccordo cambio DSG Mercedes per 1885

lc0191



1885/C3-R1 € 102,00 1 018850131

1885/C3-R2

raccordo cambio POWERSHIFT per 1885

lc0190



1885/C3-R2 € 102,00 1 018850132

1885/C3-R3

raccordi cambio Toyota IQ per 1885

lc0991



1885/C3-R3 € 102,00 1 018850133

1885/C3-R4

raccordi cambio Mazda per 1885

Ic02130



1885/C3-R4 € 102,00 1 018850134

1885/C3-R5

raccordi cambio Renault Laguna-Esp per 1885

Ic02150



1885/C3-R5 € 102,00 1 018850135

1885/C3-R6

raccordi cambio Nissan Juke per 1885

Ic02140



1885/C3-R6 € 102,00 1 018850136

1885/C3-R7

raccordi cambio AISIN TF71 FV per 1885

Ic01420



1885/C3-R7 € 102,00 1 018850137

1885/C3-R8

raccordi cambio AISIN TF71 FP per 1885

Ic001420/1



1885/C3-R8 € 102,00 1 018850138

1885/C3-R9

raccordi cambio AISIN TF71 FO per 1885

Ic001420/2



1885/C3-R9 € 102,00 1 018850139

1885/C3-R10

raccordi cambio AISIN TF71 FS per 1885

Ic001420/3



1885/C3-R10 € 102,00 1 018850140

1893/134A

stazione automatica di ricarica climatizzatori gas R134a

Modello completamente automatico, con banca dati auto/autocarri con quantità gas, quantità e tipo olio compressore, software di autodiagnosi per operazioni di manutenzione ordinaria. La banca dati è aggiornabile via software. La macchina può operare in modalità manuale (con presidio umano fase per fase) oppure in modalità completamente automatica (senza presidio).



CE



R134A (250 ml)

CARATTERISTICHE FUNZIONALI

Funzionamento automatico
Banca dati auto/autocarri con quantità gas, quantità e tipo olio compressore
Recupero automatico del gas dalla tubazione
Compensazione della ricarica della quantità di gas contenuto nelle tubazioni
Scarico automatico dei gas non condensabili
Segnalazione automatica di anomalie e manutenzione
Manometri ø 80 mm
Vacuometro digitale

CARATTERISTICHE TECNICHE

Serbatoio gas: 15 kg
Pompa vuoto: 140 l/min
Bilancia elettronica: 50kg
Scheda elettronica con display retroilluminato
Velocità di recupero: 500 g/min
Alimentazione: 220 V

1893/134A € 5.150,00 1 018930001

1893/1234YF

stazione automatica di ricarica climatizzatori gas R1234yf

Modello completamente automatico, con banca dati auto/autocarri con quantità gas, quantità e tipo olio compressore, software di autodiagnosi per operazioni di manutenzione ordinaria. La banca dati è aggiornabile via software. La macchina può operare in modalità manuale (con presidio umano fase per fase), oppure in modalità completamente automatica (senza presidio).



CE



1234YF (250 ml)

CARATTERISTICHE FUNZIONALI

Funzionamento automatico
Banca dati auto/autocarri con quantità gas, quantità e tipo olio compressore
Recupero automatico del gas dalla tubazione
Compensazione della ricarica della quantità di gas contenuto nelle tubazioni
Scarico automatico dei gas non condensabili
Segnalazione automatica di anomalie e manutenzione
Manometri ø 80 mm
Vacuometro digitale

CARATTERISTICHE TECNICHE

Serbatoio gas: 15 kg
Pompa vuoto: 140 l/min
Bilancia elettronica: 50 kg
Scheda elettronica con display retroilluminato
Velocità di recupero: 500 g/min
Alimentazione: 220 V

1893/1234YF € 5.320,00 1 018930012

1893TR/134A

tracciante per gas R134a



1893TR/134A ml 250 € 36,00 1 018930901

1893TR/1234YF

tracciante per gas R1234yf



1893TR/1234YF ml 250 € 41,00 1 018930902



1893TR/CI

traccianti per compressori ibridi



1893TR/CI ml 250 € 43,00 1 018930903

1895G

generatore di comando per elettroiniettori (benzina e GPL) ed elettrovalvole

Permette di testare in completa autonomia l'efficienza di componenti come:

- elettrovalvole EGR
- elettroiniettori di motori benzina e GPL
- elettrovalvole regolazione turbina a geometria variabile
- compressori per climatizzatori di nuova generazione



VANTAGGI

- Permette di capire se il componente è meccanicamente funzionante
- In abbinamento a vasche ad ultrasuoni rende più efficace la pulizia dei componenti comandando elettronicamente il componente durante la fase di lavaggio
- Nel controllo dei climatizzatori è indispensabile per stabilire l'efficienza del compressore e della sua valvola regolatrice

CARATTERISTICHE TECNICHE

Comando iniettori benzina e GPL:

- numero uscite: 4
- durata test: 1-60 s
- Tempo apertura: 5-10 ms
- Regolazione frequenza impulso: 1-10 Hz

Comando dispositivi PWM:

- numero uscite: 1
- durata test: 1-60 min
- Automatico o manuale
- Regolazione duty cycle: 10%-85%
- Regolazione frequenza segnale: 120-250 Hz

Include 4 connettori con terminali faston femmina
Alimentazione: 110-220 V
Dimensioni: 334x240x74 mm
Peso: 4 kg

1895G € 1.540,00 1 018950800

1895/S

supporto regolabile per vasche ultrasuoni 1895

Permette il corretto posizionamento degli iniettori durante la fase di lavaggio all'interno della vasca ultrasuoni
Compatibile con i modelli di vasche da 6, 13, 27 litri

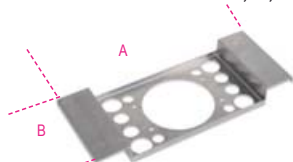

1895/S A mm 340 B mm 140 € 91,00 1 018950501

1895 6

vasca di lavaggio ad ultrasuoni da 6 litri

con funzione speciale di degassificazione



- attraverso il riscaldamento del liquido e con l'azione degli ultrasuoni permette di pulire efficacemente parti di ricambio e pezzi metallici in genere (iniettori, carburatori, valvole, ecc...)
- display digitale con regolazione della temperatura e del tempo di lavaggio
- doppia funzione lavaggio: "soft" e "normal"
- per una pulizia generale è sufficiente usare acqua ad una temperatura di 50/60°C
- per una pulizia più accurata aggiungere soluzioni detergenti non schiumogene (tipo Arexons Fulcron Extra) specifiche per vasche ad ultrasuoni
- la funzione degassificazione accelera la liberazione d'aria in tutto il volume della vasca aumentando l'efficacia degli ultrasuoni

DATI TECNICI

Capacità vasca: 6 litri
Rubinetto di scarico
Potenza: 150 Watt
Potenza di riscaldamento: 300 Watt
Regolazione temperatura: 0÷80°C
Regolazione tempo di lavaggio: 0-99 minuti
Frequenza: 40 kHz
Alimentazione: 220/230V
Dimensioni: 330x180x310 mm
Dimensioni serbatoio: 300x155x150 mm
Dimensioni cestello: 250x105x100 mm
Portata massima: 5,5 kg

1895 6 Max 5,5 € 592,00 1 018950060

1895 13

vasca di lavaggio ad ultrasuoni da 13 litri

con funzione speciale di degassificazione



- attraverso il riscaldamento del liquido e con l'azione degli ultrasuoni permette di pulire efficacemente parti di ricambio e pezzi metallici in genere (iniettori, carburatori, valvole, ecc...)
- display digitale con regolazione della temperatura e del tempo di lavaggio
- doppia funzione lavaggio: "soft" e "normal"
- per una pulizia generale è sufficiente usare acqua ad una temperatura di 50/60°C
- per una pulizia più accurata aggiungere soluzioni detergenti non schiumogene (tipo Arexons Fulcron Extra) specifiche per vasche ad ultrasuoni
- la funzione degassificazione accelera la liberazione d'aria in tutto il volume della vasca aumentando l'efficacia degli ultrasuoni

DATI TECNICI

Capacità vasca: 13 litri
Rubinetto di scarico
Potenza: 300 Watt
Potenza di riscaldamento: 400 Watt
Regolazione temperatura: 0÷80°C
Regolazione tempo di lavaggio: 0-99 minuti
Frequenza: 40 kHz
Alimentazione: 220/230V
Dimensioni: 350x325x320 mm
Dimensioni serbatoio: 325x235x145 mm
Dimensioni cestello: 257x185x100 mm
Portata massima: 12 kg

1895 13 Max 12 € 920,00 1 018950130

1895 27

vasca di lavaggio ad ultrasuoni da 27 litri

con funzione speciale di degassificazione



- attraverso il riscaldamento del liquido e con l'azione degli ultrasuoni permette di pulire efficacemente parti di ricambio e pezzi metallici in genere (iniettori, carburatori, valvole, ecc...)
- display digitale con regolazione della temperatura e del tempo di lavaggio
- doppia funzione lavaggio: "soft" e "normal" - per una pulizia generale è sufficiente usare acqua ad una temperatura di 50/60°C
- per una pulizia più accurata aggiungere soluzioni detergenti non schiumogene (tipo Arexons Fulcron Extra) specifiche per vasche ad ultrasuoni
- la funzione degassificazione accelera la liberazione d'aria in tutto il volume della vasca aumentando l'efficacia degli ultrasuoni

DATI TECNICI

Capacità vasca: 27 litri
Rubinetto di scarico
Potenza: 500 Watt
Potenza di riscaldamento: 500 Watt
Regolazione temperatura: 0÷80°C
Regolazione tempo di lavaggio: 0-99 minuti
Frequenza: 40 kHz
Alimentazione: 220/230V
Dimensioni: 530x330x380 mm
Dimensioni serbatoio: 500x300x200 mm
Dimensioni cestello: 450x250x150 mm
Portata massima: 25 kg

1895 27 Max 25 € 1.285,00 1 018950270

1895/RC

cestello per vasche ad ultrasuoni 1895



	L mm	L1 mm	A mm	€		
1895/RC6	250	105	100	38,00	1	018950506
1895/RC13	257	185	100	60,00	1	018950513
1895/RC27	450	250	150	100,00	1	018950527



1897

sabbiatrice da banco professionale

Particolarmente indicata per operazioni di finitura superficiale di vari materiali (metallo, plastica, vetro, ceramica, legno, ecc.). La cabina è realizzata in lamiera di acciaio con opportuni rinforzi per assicurare la massima robustezza e stabilità.

La cabina è dotata di:

- porta di carico con chiusura a magneti
- piano in lamiera forata
- attacco standard per aspiratori \varnothing 36 mm
- finestra di visualizzazione in policarbonato protettivo da 6 mm
- illuminazione con lampada a LED
- circuito pneumatico (entrata aria compressa)
- pistola di sabbatura con funzionamento a grilletto



CE

DATI TECNICI

Dimensioni utili cabina: 600x520x320 mm
 Dimensioni di ingombro: 660x530x500 mm
 Peso: 38 kg
 Piano lavoro: lamiera forata
 Illuminazione: LED
 Consumo aria: 340 l/min a 7 atm
 Alimentazione: 220 V - 50 Hz

1897 € 2.850,00 1 018970066

1897/KSA

sabbiatrice da banco articolo 1897 completa di aspiratore articolo 1871M/AS

CE



1897/KSA € 3.850,00 1 018970660

1897/CRB

corindone per sabbiatrice 1897 in sacco da 25 kg



1897/CRB € 143,00 1 018970101

1897/G

garnet per sabbiatrice 1897 in sacco da 25 kg



1897/G € 115,00 1 018970104

1897/MV

microsfere di vetro per sabbiatrice 1897 in sacco da 25 kg



1897/MV € 189,00 1 018970103

1898/K40

vasca manuale per la pulizia di pezzi meccanici a ricircolo con liquido riscaldato e batteri.

- permette l'eliminazione dei costi di smaltimento per solventi o idrocarburi
- utilizzando il detergente ecologico Beta a base di enzimi e batteri permette la rimozione e lo smaltimento dei vari residui oleosi presenti sui pezzi meccanici
- la funzione enzimatica aiuta a scindere la parte oleosa dalla parte solida di sporco mentre i batteri trasformano la stessa in anidride carbonica e acqua rigenerando costantemente il detergente

CE



DOTATA DI:

- spazzola a setole lunghe e tubazione di collegamento
- predisposizione per utilizzo destrorso e sinistrorso
- griglia forata in acciaio inox
- ruote con freno
- scheda con display per visualizzazione temperatura di funzionamento ed avviso livello troppo basso

INCLUDE:

- n° 2 taniche di liquido detergente ecocompatibile da 20 litri e n° 2 confezioni di batteri

DATI TECNICI

- Portata massima pompa: 10 litri/minuto
- Capacità serbatoio: 40 litri
- Temperatura di funzionamento: +5°C ÷ +40°C
- Dimensioni: 900 x 1000 x 750 mm
- Dimensioni interne vasca: 710 x 370 x 200 mm
- Peso: 50 kg a vuoto

1898/K40 € 3.780,00 1 018980004

ATTENZIONE:

Paesi in cui possibile distribuire il prodotto 1898/K40 sono: Austria, Belgio, Francia, Italia, Paesi Bassi, Polonia, Portogallo, Regno Unito, Spagna, Ungheria

1898/B

flacone di batteri da 400 ml per vasca lava pezzi 1898/K40



1898/B € 78,00 1 018980904

ATTENZIONE:

paesi in cui è possibile distribuire il prodotto 1898/B sono: Austria, Belgio, Francia, Italia, Paesi Bassi, Portogallo, Regno Unito, Spagna, Ungheria

1898/D

tanica di liquido detergente ecocompatibile da 20 litri per vasca lava pezzi 1898/K40



1898/D € 155,00 1 018980920

ATTENZIONE:

paesi in cui è possibile distribuire il prodotto 1898/B sono: Austria, Belgio, Francia, Italia, Paesi Bassi, Portogallo, Regno Unito, Spagna, Ungheria

2250-O

seggolino girevole con vassoio



2250-O € 86,50 1 022500011

2251-O

seggolino girevole con cassetti



2251-O € 154,00 1 022510011

2252

seggolino con rotelle

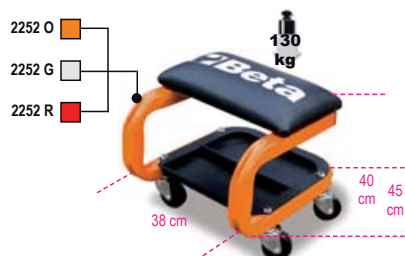

2252-O	149,50	1	022520001
2252-G	149,50	1	022520002
2252-R	149,50	1	022520003

2252KR4

4 ruote di ricambio seggiolino 2252



2252KR4	50,50	1	022520900
---------	-------	---	-----------

2258-O

seggolino con cassettera



2258-O	155,00	1	022580011
--------	--------	---	-----------

2254C

protezione a ventosa per carrozzeria veicoli

In tessuto plastificato con 4 ventose sul lato superiore



2254C	41,00	1	022540200
-------	-------	---	-----------

2254F

protezione anteriore auto

Permette di proteggere la parte frontale del veicolo lasciando le aperture per i fari e il radiatore



- Lavabile
- Impermeabile e resistente ad oli e grassi
- Fissaggio tramite lacci
- Materiale: 98% poliammide/nylon, 2% poliuretano

2254F	71,00	1	022540150
-------	-------	---	-----------

2254K

protezione riutilizzabile per sedile, volante e pomello del cambio
adatta alla maggior parte dei sedili, volanti e pomelli dei cambi di autoveicoli



2254K	24,00	1	022540101
-------	-------	---	-----------

2254SM

tappeto sottomacchina in EVA

doppia finitura:

- 1 lato in morbido EVA
- 1 lato in carbon look rigido per favorire lo scivolamento



2254SM	56,00	1	022540033
--------	-------	---	-----------

2254T

tappeto per protezione ginocchia

Realizzato in EVA anticivolo



2254T	24,50	1	022540047
-------	-------	---	-----------

3000M/LT

lettino sottomacchina

- Rivestimento in PVC con imbottitura in gomma piuma per un elevato comfort.

REGOLAZIONE DEL CUSCINO TRAMITE PISTONE A MOLLA PROGRESSIVA



3000M/LT	143,00	1	030000220
----------	--------	---	-----------

7,3 kg

3000M/RLS

ruota di ricambio lettino sottomacchina



3000M/RLS	10,40	1	030000206
-----------	-------	---	-----------

3002

lettino sottomacchina e seggiolino

- struttura in acciaio
- rivestimento in PVC con imbottitura
- possibilità di regolare la posizione rapidamente: lettino o seggiolino



3002	95,00	1	030020001
------	-------	---	-----------

3002/RLS

6 ruote di ricambio per lettino sottomacchina. 3002



3002/RLS	24,50	1	030020501
----------	-------	---	-----------

3003

lettino sottomacchina in plastica antiurto

• Ø ruote: 76 mm



3003 € 74,00 1 030030001

3003/RLS

6 ruote di ricambio per lettino sottomacchina 3003



3003/RLS € 38,50 1 030030501

3003C

lettino sottomacchina in plastica antiurto

Dotato di:
- cuscino per la testa e per la zona lombare con finitura in carbon look
- piastrine superiori in metallo per il fissaggio di accessori magnetici
- 6 ruote in gomma con diametro 79 mm
- Portata max. 120 Kg
- Peso 5,5 Kg



3003C € 199,00 1 030030100

3003C/RLS

6 ruote di ricambio per lettino sottomacchina 3003C



3003C/RLS € 80,00 1 030030600

3003PRO

lettino sottomacchina in materiale plastico antiurto

Dotato di:
- cuscino poggiatesta ergonomico
- protezione morbida per la schiena
- 2 ruote da 178 mm con doppio cuscinetto che permettono l'utilizzo anche su superfici sconnesse e il superamento di tubi/cavi
- 1 ruota girevole
- doppia regolazione dell'altezza da terra: 38 o 76 mm
- 2 lampade a led portatili da 250 lumen con magneti per fissaggio
- capacità di carico: 200 kg
- peso: 7,7 kg



C max H min H Max H1
kg mm mm mm
200 170 230 230 € 280,00 1 030030150

3003PRO/SP

supporto in plastica da parete per lettino 3003PRO

Può essere applicato su una parete, ponte, cassetteria o altro permettendo il fissaggio del lettino attraverso un sistema rapido e veloce con chiusura di sicurezza.



3003PRO/SP € 75,00 1 030030151

3003PRO/PM

portaminuterie magnetico tondo per lettino 3003PRO

applicandolo sul cerchio delle ruote del lettino permette il trattamento delle minuterie durante gli interventi



3003PRO/PM € 8,00 1 030030152

3003PRO/RCR

coppia ruote di ricambio posteriori per lettino sottomacchina 3003PRO



3003PRO/RCR € 60,00 1 030030650

3003PRO/RRG

ruota di ricambio girevole anteriore per lettino sottomacchina 3003PRO



3003PRO/RRG € 18,50 1 030030651

3003PRO/RT

lampada a led con magneti di ricambio per lettino sottomacchina 3003PRO

• 250 lumen
• pile : 4xAAA non incluse



3003PRO/RT € 13,50 1 030030652

3006

sollevatore e posizionario ruote trattori ed escavatori

• portata massima 1500 kg
• diametro ruota minimo 1000 mm
• diametro ruota massimo 2200 mm
• spessore ruota massimo 800 mm

CE



3006 € 1.475,00 1 030060000

3006 R/RGF

ruota girevole con freno di ricambio per sollevatore e posizionario ruote 3006



3006 R/RGF € 57,00 1 030060501

3006 R/RG

ruota girevole di ricambio per sollevatore e posizionario ruote 3006



3006 R/RG € 49,00 1 030060502

3007

carrello sottoscocca per veicoli
senza meccanica anteriore/posteriore

per movimentare agevolmente i veicoli
privi di avantreno o retrotreno durante le fasi di lavorazione

- 4 ruote pivotanti, di cui 2 con freno, adatte all'uso in forno di verniciatura
- 2 supporti scorrevoli per adattarsi a tutti i telai
- portata massima 800 kg

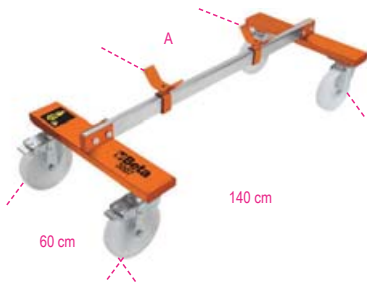

3007 A Max mm 110 € 480,00 1 030070001

3007 R/RGF

ruota girevole con freno di ricambio per
carrello sottoscocca per veicoli 3007



3007 R/RGF € 85,00 1 030070501

3007 R/RG

ruota girevole di ricambio per
carrello sottoscocca per veicoli 3007



3007 R/RG € 74,00 1 030070502

3008

sollevatore e posizionatore
ruote Truck singole e gemellari

- portata massima 800 kg
- altezza minima 140 mm
- altezza massima 660 mm
- interasse rulli 470÷740 mm
- sicurezza idraulica in caso di sovraccarico
- ruote anteriori pivotanti

CE



3008 € 2.560,00 1 030080100

3009

carrello per movimentazione veicoli

- portata Max 550 kg
- 4 rulli basculanti
- larghezza rulli 200 mm
- per ruote fino a 240 mm di larghezza



3009 A B € 355,00 1 030090001

3009R/GR4

gruppi 4 ruote carrelli 3009 R/GR4



3009R/GR4 € 145,00 1 030090501

3010/T...

coppia cavalletti



C max kg	H min mm	H Max mm	H1 mm	L mm	L1 mm
2000	280	425	245	185	165

3010T 2 € 84,00 1 030100002

C max kg	H min mm	H Max mm	H1 mm	L mm	L1 mm
3000	285	430	250	180	195

3010T 3 € 99,00 1 030100003

C max kg	H min mm	H Max mm	H1 mm	L mm	L1 mm
6000	400	580	340	245	280

3010T 6 € 144,00 1 030100006

C max kg	H min mm	H Max mm	H1 mm	L mm	L1 mm
10000	471	735	420	330	290

3010T 10 € 248,00 1 030100010

3011/T

sollevatori idraulici a bottiglia

CE



C max kg	H min mm	H Max mm	L mm
3500	170	366	86

3011T 3,5 € 84,00 1 030110035

C max kg	H min mm	H Max mm	L mm
5000	203	467	118

3011T 5 € 94,00 1 030110050

C max kg	H min mm	H Max mm	L mm
10000	220	484	114

3011T 10 € 140,00 1 030110100

C max kg	H min mm	H Max mm	L mm
15000	230	497	113

3011T 15 € 172,00 1 030110150

C max kg	H min mm	H Max mm	L mm
20.000	245	521	115

3011T 20 € 247,00 1 030110200

3010H

cavalletti serie pesante



C Max kg	H min mm	H Max mm	L mm	L1 mm
15.000	450	750	300	300

3010H 750 € 255,00 1 030100150

C Max kg	H min mm	H Max mm	L mm	L1 mm
15.000	650	1100	300	300

3010H 1100 € 320,00 1 030100165

3010V

cavalletti serie pesante
con regolazione a vite



C Max kg	H min mm	H Max mm	L mm	L1 mm
20,000	470	680	300	300

3010V 680 € 380,00 1 030100200

C Max kg	H min mm	H Max mm	L mm	L1 mm
20,000	680	1170	300	300

3010V 1170 € 485,00 1 030100220

3012

staffe sostegno motore



L mm	C max kg	€	1	030120010
1500	500	256,00	1	030120010
1800	400	346,00	1	030120018

3012C

staffa sostegno motore inferiore

ideale per auto e veicoli commerciali



3012C € 675,00 1 030120255

3012I

staffa sostegno motore inferiore

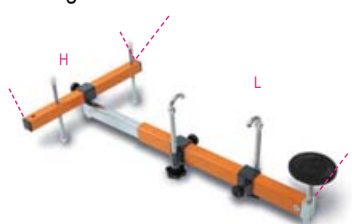

L mm	H mm	€	1	030120250
630-960	190	598,00	1	030120250

3014

cavalletto sostegno motore



3014 € 322,00 1 030140010

3014R/GR5

5 ruote di ricambio per cavalletto sostegno motore 3014



3014R/GR5 € 80,50 1 030140501

3014 SAR

cavalletto sostegno motore richiudibile

- facilmente richiudibile con notevole riduzione degli ingombri
 - permette la rotazione di 360° del motore o del cambio
 - garantisce la massima sicurezza e stabilità durante gli interventi
- Portata massima: 450 kg



3014SAR € 1.176,00 1 030140360

3014SAR/RR

4 ruote di ricambio per cavalletto sostegno motore 3014SAR



3014SAR/RR € 129,00 1 030140370

3014SAR/1

vasca di raccolta liquidi
per 3014 SAR

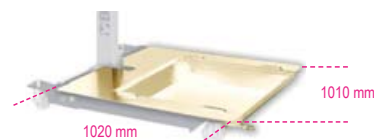

3014SAR/1 € 345,00 1 030140361
1020x1010x11 mm

3014SAR/2

staffa per il fissaggio della trasmissione sul cavalletto 3014 SAR

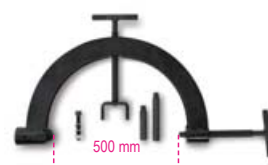

3014SAR/2 € 333,00 1 030140362

3025

gru idraulica pieghevole
con pompa a doppio effetto
Portata massima 1 t

CE



3025 3025 € 1.600,00 1 030250001

3025/RF

2 ruote fisse di ricambio per gru idraulica 3025



3025/RF € 204,00 1 030250901

3025/RG

2 ruote girevoli di ricambio per gru idraulica 3025



3025/RG € 300,00 1 030250902

3025/PF

pinza movimentazione fusti

portata massima 300 kg

CE



3025/PF	A mm	B mm	€		
	550+640	70	255,00	1	030250011

3026 0,3

sollevatore idraulico da fossa e sottoponte

Portata massima: 300 kg

CE



3026 0,3	€		
	585,00	1	030260003

3026/R0,3

4 ruote girevoli di ricambio per sollevatore idraulico 3026 0,3



3026/R 0,3	€		
	148,00	1	030260903

3026 0,5

sollevatore idraulico da fossa e sottoponte

Portata massima 500 kg

CE



3026 0,5	€		
	695,00	1	030260005

3026/R0,5

4 ruote girevoli di ricambio per sollevatore idraulico 3026 0,5



3026/R 0,5	€		
	220,00	1	030260905

3026 1,0

sollevatore idraulico da fossa e sottoponte

Portata massima 1t

CE



3026 1,0	€		
	840,00	1	030260010

3026/R 1,0

4 ruote girevoli di ricambio per sollevatore idraulico 3026 1,0



3026/R 1,0	€		
	264,00	1	030260910

3026/S

supporto orientabile per trasmissioni con boccole di riduzione per sollevatori 3026

portata massima 500 kg



3026/S	€		
	490,00	1	030260501

3026/SP

supporto universale per trasmissioni

permette ad un solo operatore di smontare e rimontare le trasmissioni di autovetture, veicoli commerciali e fuoristrada con rapidità e sicurezza.

DATI TECNICI

Adatto per steli con diametro: 25-30-35-45 mm

Portata massima: 150 kg

Altezza: 250 mm



3026/SP	€		
	570,00	1	030260505

3026/SA

supporto mozzo ruota per sollevatori da fossa

- utilizzabile per interventi di manutenzione inerenti ai mozzi, e durante le operazioni di sostituzione degli ammortizzatori
- adattabile ai sollevatori idraulici da fossa 3026 0,3 e 3026 0,5



3026/SA	Ø mm	€	
	30,4	119,00	1 030260510

3026/SAM

supporto ammortizzatori per sollevatori da fossa

- utilizzabile per sostenere l'ammortizzatore quando si smonta il braccio della sospensione
- staffa per ammortizzatori con diametro Max 80 mm, più riduzione per diametri Max 60 mm
- adattabile ai sollevatori idraulici da fossa 3026 0,3 e 3026 0,5



3026/SAM	€		
	154,00	1	030260515

3027 10

pressa idraulica da banco con pistone mobile

capacità massima: 10 t

CE



3027 10 € 1.410,00 1 030270010
90 kg

3027 20

pressa idraulica con pistone mobile

capacità massima: 20 t

CE



3027 20 € 1.960,00 1 030270020
140 kg

3027 30

pressa idraulica con pistone mobile ed argano

capacità massima: 30 t

CE



3027 30 € 3.410,00 1 030270030
230 kg

3027 50

pressa idraulica con pistone mobile ed argano

capacità massima: 50 t

CE



3027 50 € 4.660,00 1 030270050
350 kg

3027/KP

serie di cacciapine e piastra per pressa 3027



		€		
3027/KP10	3027 10	315,00	1	030270510
3027/KP20	3027 20	420,00	1	030270520
3027/KP30	3027 30	420,00	1	030270530
3027/KP50	3027 50	495,00	1	030270550

3027/KPP50

comando a pedale per pressa idraulica 3027 20-30-50



3027/KPP50 € 209,00 1 030270555

3027/PR

supporto pressa per estrazione/introduzione mozzi, cuscinetti e silent block

Sistema universale che, operando sotto pressa, attraverso una base di appoggio e relativi accessori, permette lo smontaggio/montaggio di mozzi, cuscinetti e silent block dalla loro sede. L'attrezzo si adatta alle conformazioni geometriche irregolari dei mozzi/perni fusi sui quali l'operatore deve intervenire.



DATI TECNICI

Campo di lavoro: Min. 130 mm - Max. 186 mm
Dimensioni: 300 x 300 mm
Peso: 13 kg
Portata massima: 20 t

3027/PR € 524,00 1 030270400

3029/2T

sollevatore idraulico ribassato a 4 ruote da 2 tonnellate

- Pedale di avvicinamento rapido
- Struttura in acciaio e ruote in nylon
- Altezza minima 75 mm

CE



3029/2T € 345,00 1 030290020

3029L/2T

sollevatore idraulico lungo ribassato da 2 tonnellate

- Permette di operare su veicoli con bassa altezza da terra e punto di sollevamento interno
- Velocità di discesa controllata
 - Pedale di avvicinamento rapido
 - Ruote in nylon

CE



3029L/2T € 400,00 1 030290120

3029/2T-L/RP

piattello di ricambio in gomma 85 mm per 3029/2T, 3029L/2T



3029/2T-L/RP € 13,50 1 030290502

3029/2T-L/R6

ruota posteriore di ricambio per 3029/2T, 3029L/2T



3029/2T-L/R6 € 44,50 1 030290506

3029/2T-L/R5

ruota anteriore di ricambio per sollevatore 3029/2T, 3029L/2T



3029/2T-L/R5 € 40,50 1 030290505

3030/2T

sollevatore idraulico ribassato 2 t a 6 ruote

- doppie ruote anteriori basculanti in materiale plastico (PTFE)
- ottima manovrabilità del sollevatore su pavimentazioni sconnesse e irregolari
- portata massima: 2 tonnellate



3030/2T € 670,00 1 030300020

43 kg

3030/2T-R5

ruota anteriore con perno per sollevatore 3030 2T



3030 2T/R5 € 23,50 1 030300505

3030/2T-R6

ruota posteriore di ricambio per 3030/2T, 3033/3T



3030 2T/R6 € 36,50 1 030300506

3030/2TRP

piattello di ricambio in gomma 85 mm per 3030/2T, 3033/3T



3030/2TRP € 4,70 5 030300501

3033/3T

sollevatore idraulico 3t versione lunga

- per utilizzo su veicoli commerciali
- portata massima: 3 tonnellate
- ruote in poliammide

CE



3033/3T € 870,00 1 030330030



3035

carrello trasporta pneumatici

- per trasportare agevolmente pneumatici fino ad un massimo di 980 mm di diametro
- la solida struttura permette di movimentare i pneumatici senza doverne sopportare fisicamente il peso
- utilizzabile come piano d'appoggio, grazie al blocco della posizione in orizzontale
- 2 ruote Ø 260 mm
- 2 ruote Ø 125 mm
- altezza massima trasportabile 1,60 m
- portata massima 200 kg
- forche regolabili in 2 posizioni: prima posizione apertura massima 880 mm seconda posizione apertura massima 980 mm



3035 € 808,00 1 030350100

3036

base per movimentazione ruote

ruote in gomma antitraccia



3036 € 96,00 1 030360063

3061/2T

sollevatore pneumatico 2 t - 2 stadi

CE



Dotato di:

- membrana alta resistenza a tre strati e guida telescopica interna
- dispositivo d'arresto a fine corsa e valvola di sicurezza per carichi eccessivi
- possibilità di utilizzo anche sui ponti sollevatori

DATI TECNICI

portata: 2 t
 peso: 14 kg
 pressione di alimentazione: 8-10 bar
 altezza: min. 132 - max. 326 mm

3061/2T € 750,00 1 030610020

3061/2T-P50

prolunga da 50 mm per 3061/2T



3061/2T P50 € 63,50 1 030610021

3061/2T-P100

prolunga da 100 mm per 3061/2T



3061/2T P100 € 86,00 1 030610022

3065/20-10T

sollevatore oleopneumatico 20-10T con valigia di trasporto

Portatile e leggero, ideale per gli interventi di assistenza su strada

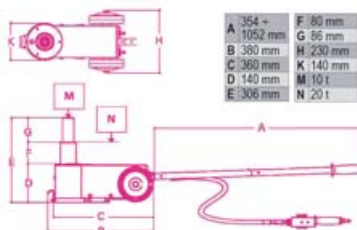

• include due prolunghe da 75 e 60 mm

DATI TECNICI

portata: 20-10 tonnellate
 peso: 23 kg
 pressione di alimentazione: 8-10 bar
 consumo d'aria: 400 nl/min

3065/20-10T € 2.215,00 1 030650100

3065/40-20T

sollevatore oleopneumatico 40-20 t

CE

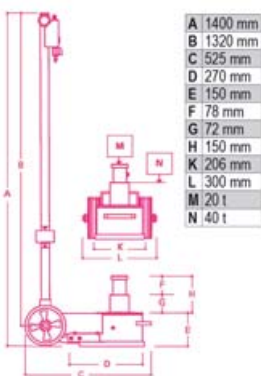

- indicato per utilizzo su mezzi pesanti
- pratico e maneggevole per trasporto anche su officine mobili
- rientro automatico dei pistoni
- due valvole di discesa con controllo velocità sotto carico
- include due prolunghe da 70 e 120 mm

DATI TECNICI

portata: 40-20 tonnellate
 peso: 39 kg
 pressione di alimentazione: 8-10 bar
 consumo d'aria: 400 l/min

3065/40 20T € 2.520,00 1 030650200

3067/60-15T

sollevatore oleopneumatico 60-30-15T

Con un'altezza minima di soli 120 mm è particolarmente indicato per utilizzo su autobus, pullman e mezzi di trasporto pubblici

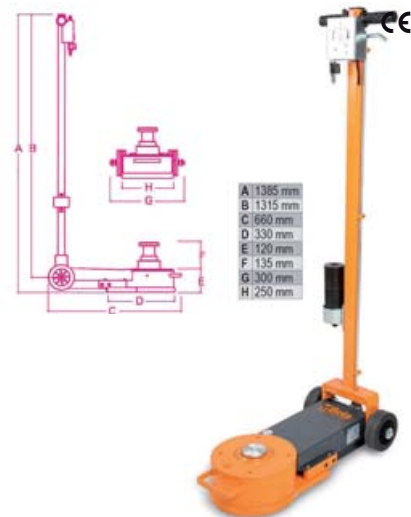

A	1385 mm
B	1315 mm
C	660 mm
D	330 mm
E	120 mm
F	135 mm
G	300 mm
H	250 mm

- rientro automatico dei pistoni
- due valvole di discesa con controllo velocità sotto carico
- include due prolunghe da 70 e 120 mm

DATI TECNICI

portata: 60-30-15 tonnellate
 peso: 56 kg
 pressione di alimentazione: 8-10 bar
 consumo d'aria: 600 l/min

3067/60-30-15T € 3.670,00 1 030670120

3067/70-13T

sollevatore oleopneumatico 70-43-23-13 t

CE

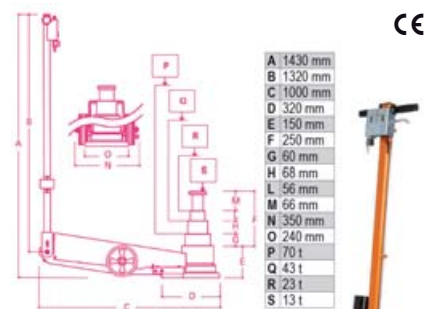

- Versione lunga, adatta all'utilizzo su autocarri, autoarticolati, autobus e macchine agricole
- rientro automatico dei pistoni
- due valvole di discesa con controllo velocità sotto carico
- include due prolunghe da 70 e 120 mm

DATI TECNICI

portata: 70-43-23-13 tonnellate
 peso: 74 kg
 pressione di alimentazione: 8-10 bar
 consumo d'aria: 600 l/min

3067/70 13T € 4.630,00 1 030670130

Beta



UTENSILI PER MOTORIPARAZIONE

La qualità e l'affidabilità dei prodotti Beta sono garantite da oltre ottant'anni di esperienza e tradizione. Prodotti continuamente aggiornati la cui qualità è altamente apprezzata dai tecnici delle migliori squadre corse nel Motomondiale, Mondiale Superbike, Mondiale Motocross ed Enduro.

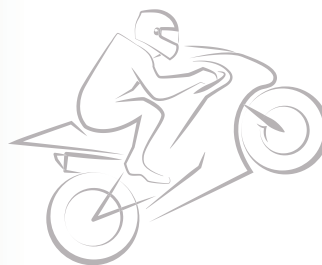

3040C

cavalletto posteriore per moto regolabile

- Verniciatura nera opaca
- 4 ruote in gomma termoplastica
- Include coppia di cursori a V
- Include coppia di cursori a L



3040C € 65,00 1 030400002

3040C/S1

coppia cursori a V per 3040C



3040C/S1 € 10,20 1 030400503

3040C/S2

coppia cursori a L in gomma per 3040C



3040C/S2 € 14,80 1 030400504

3041C

cavalletto anteriore per moto regolabile

- Verniciatura nera opaca
- 4 ruote in gomma termoplastica
- Include coppia di cursori a rulli
- Include coppia di cursori a cono



3041C € 61,00 1 030410002

3041C/12

coppia cursori a rulli per 3041C



3041C/12 € 14,30 1 030410512

3041C/16

coppia cursori a cono per 3041C



3041C/16 € 9,70 1 030410516

3042C

cavalletto anteriore per canotto di sterzo moto

- Verniciatura nera opaca
- 4 ruote in gomma termoplastica
- Include kit di 8 perni Ø 13 - 15 - 15,5 - 17 - 19 - 20 - 21 - 27



3042C € 110,00 1 030420002

3043C

cavalletto per moto con monobraccio sinistro

- Verniciatura nera opaca
- 4 ruote in gomma termoplastica
- Perno optional



3043C € 80,00 1 030430002

3043C/ 41÷47

perno per 3043C



	Ø mm	€		
3043C/41 Ducati	21,5 ÷ 25,5	18,30	1	030430551
3043C/42 KTM - Triumph	27,5	18,30	1	030430552
3043C/43 MV	42,5	19,80	1	030430553
3043C/44 Ducati	40,5	19,80	1	030430554
3043C/45 Honda	28,5	18,30	1	030430555
3043C/47 BMW	53,5	23,50	1	030430557

3047C

cavalletto cross/enduro a pedale



3047C € 50,50 1 030470002

3048C

cavalletto cross racing in acciaio



3048C € 50,50 1 030480002

3050/CC

cavalletto centrale a vite sotto culla per Custom, Enduro, Cross, Scooter

Include kit di supporti regolabili

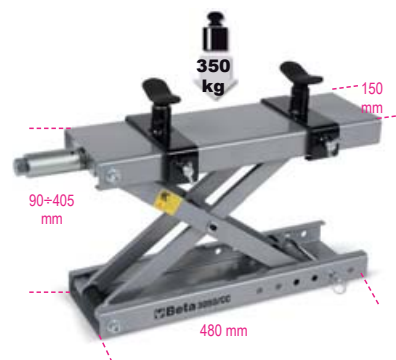

3050/CC € 130,00 1 030500012

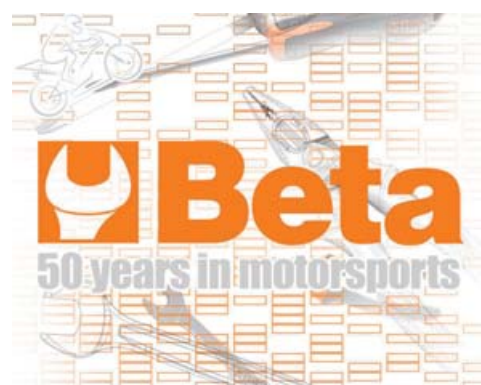

3050/600

sollevatore moto elettroidraulico da 600 kg



CE



- 3050/O
- 3050/G
- 3050/R

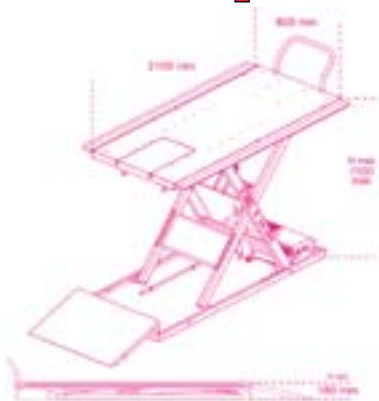

Caratteristiche tecniche

- sicurezze elettriche, meccaniche e idrauliche
- portata: 600 kg
- centralina elettroidraulica integrata: 230V - 50 Hz
- pompa idraulica
- velocità di discesa controllata
- fusibili di sicurezza in caso di tranciatura del cavo
- pulsantiera di comando
- certificato CE omologato TÜV

	L	L	H min	H Max	€		
	mm	mm	mm	mm			
3050/O	975	2100	185	1110	4.400,00	1	030500201
3050/G	975	2100	185	1110	4.400,00	1	030500202
3050/R	975	2100	185	1110	4.400,00	1	030500203

3050/KA

kit di allargamento per sollevatore 3050/600

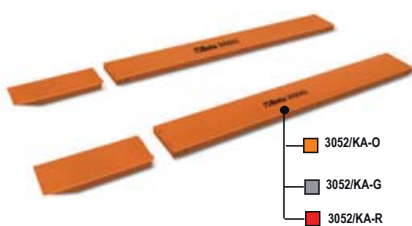

- 3052/KA-O
- 3052/KA-G
- 3052/KA-R

	A	B	€		
	mm	mm			
3050/KA-O	107,5	2100	880,00	1	030500221
3050/KA-G	107,5	2100	880,00	1	030500222
3050/KA-R	107,5	2100	880,00	1	030500223

3050/MS

morsa bloccaruota per sollevatore 3050/600



permette il bloccaggio della ruota anteriore della moto sul ponte



3050/MS	500,00	1	030500032
---------	--------	---	-----------

3050/MV

morsa bloccaruota meccanica a vite per sollevatore 3050/600



3050/MV	835,00	1	030500034
---------	--------	---	-----------

3050/LA

piano in lamiera antiscivolo per sollevatore 3050/600

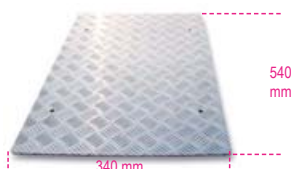

3050/LA	90,00	1	030500062
---------	-------	---	-----------

9562T3

tappeto da officina 300x160 cm



- particolarmente indicato per l'utilizzo sotto ponti sollevatori moto
- protegge il suolo da perdite d'olio, benzina e rispetta l'ambiente
- facile da pulire, fondo gommato ed antiscivolo



9562T3	279,00	1	095620300
--------	--------	---	-----------

3054

base mobile per cavalletto centrale o per ruota posteriore moto con estensione per cavalletto laterale



3054	217,00	1	030540000
------	--------	---	-----------

3055M

morsa automatica per furgoni



permette il fissaggio della ruota anteriore della moto



3055M	83,50	1	030550002
-------	-------	---	-----------

3057

rampa in alluminio per carico/scarico moto

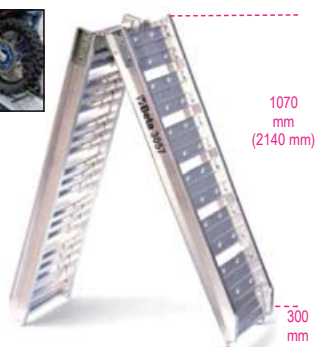

3057	177,00	1	030570001
------	--------	---	-----------

3070B

equilibratrice statica manuale



misure coni:
 Øe 30 mm - Øi 10 mm
 Øe 30 mm - Øi 12 mm
 Øe 40 mm - Øi 14 mm



- permette l'equilibratura delle ruote in officina e sui campi gara
- dotata di cuscinetti volventi, livella di posizionamento e piedini regolabili per una massima precisione
- include coppia di coni per mozzi

3070B	105,50	1	030700100
-------	--------	---	-----------



3070BE/K

equilibratrice elettronica portatile a lancio manuale

sistema di equilibratura con microprocessore a lancio manuale (senza motore) che permette l'equilibratura di ruote in ferro o in lega di auto e moto

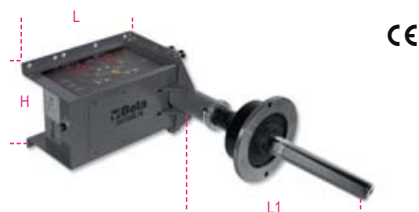

- compatta e facilmente trasportabile può essere utilizzata in officina, all'interno di furgoni o nei box dei circuiti
- può essere fissata su un banco o su una parete
- il software include tutti i programmi di correzione dello squilibrio con indicazione delle posizioni
- con pesi adesivi (ALUS), pesi nascosti dietro le razze (SPLIT) e ottimizzazione dello squilibrio
- può essere utilizzata con supporto orientabile BETA 3070BE/S (optional)

ACCESSORI INCLUSI

- righello flessibile graduato
- ghiera di serraggio con volantino e 3 coni da $\varnothing 45 \div 110$ mm

DATI TECNICI

Alimentazione: 115-230V AC o 12-24V DC
 Potenza massima assorbita: 0.15 kW
 Velocità di equilibratura: 100 rpm
 Incertezza di misura: 1 gr
 Larghezza cerchione impostabile: $1.5'' \div 20''$ (40 ÷ 510 mm)
 Peso massimo della ruota: max 75 kg

3070BE/K € 2.650,00 1 030700250

3070BE/S

supporto orientabile per equilibratrice portatile elettronica 3070BE

permette il fissaggio a parete o a banco dell'equilibratrice riducendo gli ingombri e gli spazi di installazione



3070BE/S L mm 514 L1 mm 280 € 970,00 1 030700201

3070BE/F

flangia universale motocicli $\varnothing 40$ mm per 3070BE

utilizzabile sulle ruote con foro centrale passante con \varnothing da 15 a 35 mm e sulle ruote flangiate con centratura fino a $\varnothing 68$ mm



3070BE/F € 1.320,00 1 030700202

3070BE/B

kit di 8 bussole per il centraggio delle ruote dei motocicli per 3070BE

permette di operare sui seguenti \varnothing : 28 - 25 - 22 - 20 - 19,05 - 17 - 16 - 15



3070BE/B € 1.475,00 1 030700203

3073

inseritore universale paraoli forcella

per diametri stelo da 35 a 45 mm



3073 € 70,50 1 030730001

3075A

chiave a bussola esagonale per dadi mozzo ruota



	\varnothing mm	\varnothing mm	L mm	€		
3075A 28	28	38	30	22,80	1	030750028
3075A 30	30	40	30	24,80	1	030750030

3075B

chiave a bussola poligonale per dadi mozzo ruota DUCATI



3075B \varnothing mm 55 \varnothing mm 70,7 L mm 25 € 59,00 1 030750155

3075MV

chiave a bussola poligonale per dadi mozzo ruota MV AGUSTA



3075MV 56 \varnothing mm 56 \varnothing mm 70,7 L mm 30 € 66,00 1 030750156

3075/CM

chiave esagonale maschio multipla per perni ruote



3075/CM € 33,00 1 030750212
 \varnothing 12-14-17-19-22-24 mm

3075/K10

set chiave universale a testina intercambiabile e 10 inserti, per serraggio raggi ruote

Misure: 5.2 - 5.4 - 5.6 - 5.8 - 6.0 - 6.2 - 6.4 - 6.6 - 6.8 - 7.0



3075/K10 € 44,50 1 030750410

3079/21

oliatore per cavi

Permette una corretta lubrificazione dei cavi frizione e comando gas aumentando la scorrevolezza delle guaine e la durata dei cavi.



3079/21 € 6,70 1 030790021

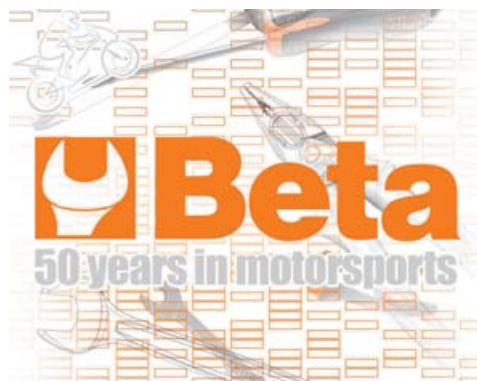

3080/C15

kit per smagliatura e ribaditura catene



Diametri 3-4-5 mm e kit regina



3080/C15 € 291,00 1 030800015

420x185x60 mm

3080R/CS3

kit di 3 cacciapina di ricambio per smagliatene 3080/C15



diametro 3-4-5 mm



3080R/CS3 € 46,00 1 030800503

3081

smagliatene portatile



Robusto e ripiegabile per facilitarne il trasporto nella borsa da endure.
Adatto a catene 415, 420, 428, 520, 525, 530, 532



3081 € 36,50 1 030810010

3085

utensile per separazione pistoncini freno



Indicato per pinze freno moto e scooter



3085 € 81,00 1 030850010

3091

estrattori con filetto interno per volano



	M	€		
3091/10	24x1,5	17,00	1	030910010
3091/20	26x1,0	17,80	1	030910020
3091/30	28x1,0	18,00	1	030910030
3091/40	30x1,0	24,00	1	030910040
3091/45	30x1,5	24,00	1	030910045
3091/50	32x1,5	26,50	1	030910050
3091/60	33x1,5	28,00	1	030910060
3091/70	35x1,0	39,00	1	030910070
3091/75	35x1,5	39,00	1	030910075
3091/80	38x1,5	42,50	1	030910080

3092

estrattori con filetto esterno per volano



	M	€		
3092/10	18x1,5	9,00	1	030920010
3092/20	19x1,0	10,50	1	030920020
3092/30	27x1,25/20x1	11,00	1	030920030
3092/35	22-26x1,5	11,00	1	030920035
3092/40	25x1,5/22x1	11,00	1	030920040
3092/50	26-28x1,0	11,00	1	030920050
3092/60	28x1,5	10,80	1	030920060

3093/E

attrezzo per bloccaggio volano, campana frizione e pulegge



3093/E € 30,00 1 030930100

3093/U

estrattore multiplo per volano



	€		
3093/U	29,50	1	030930050
M10x1.25R			
M14x1.5R			
M16x1.5R			
M18x1.5R			
M24x1.0R			
M27x1.0L			

Beta



UTENSILI PER BICICLETTA

Beta è da sempre legata al ciclismo. Questo "Speciale Utensili Bicchette" è dedicato ai professionisti del settore, ed è una selezione accurata di prodotti specifici dedicati alla manutenzione delle biciclette.

Siamo partner dell'UAE Team Emirates del Manager Giuseppe Saronni, protagonista del UCI World Tour, con il successo del Tour de France 2020.



Partnership 2020



3912T

banco TOP da officina per manutenzione biciclette

- Dotato di supporto per movimento centrale
- Cassetto porta attrezzi



3912T € 1.125,00 1 039120010

3912P

banco PRO da officina per manutenzione biciclette

- Dotato di supporto per movimento centrale



3912P € 640,00 1 039120110

3912T/AD12

coppia di adattatori con foro passante da 12 mm

- Per banco 3912T e 3912P



3912T/AD12 € 59,00 1 039120012

3912T/AD15

coppia di adattatori con foro passante da 15 mm

- Per banco 3912T e 3912P



3912T/AD15 € 62,00 1 039120015

3912T/AD20

coppia di adattatori con foro passante da 20 mm

- Per banco 3912T e 3912P



3912T/AD20 € 62,00 1 039120020

3912T/ADC

coppia di adattatori conici

- Per banco 3912T e 3912P
- Per DownHill, MTB, Cross Country



3912T/ADC € 25,00 1 039120035

3916MM

morsa monobraccio da officina per manutenzione biciclette

- Morsa girevole di 360°
- Portata 20Kg



3916MM € 650,00 1 039160110

3921

attrezzo per l'allineamento del forcellino-cambio

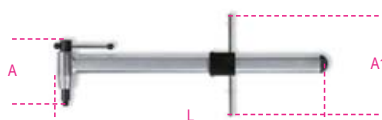

3921 € 85,00 1 039210010

3923

attrezzo guidalama per taglio reggisella di tipo aerodinamico fino a 80 mm e taglio canotti da 1" a 1.1/2"



3923 € 40,00 1 039230010

3927

bloccamanubrio



3927 € 24,00 1 039270010

3932U

smagliacatena professionale compatibile con catene da 5 a 11 velocità



3932U € 45,00 1 039320011

3935

indicatore usura catena



3935 € 7,50 1 039350010

3937

pinza per falsamaglia



3937 € 19,50 1 039370010

3948

estrattore per pedivelle



3948 € 15,00 1 039480015

3952

chiave conica semplice

• Spessore ridotto



mm	L mm	€	Icona	Icona
13	205	19,50	2	039520013
14	205	19,50	2	039520014
15	205	19,50	2	039520015
16	205	19,50	2	039520016
17	205	19,50	2	039520017
18	205	19,50	2	039520018
19	205	19,50	2	039520019
20	205	20,00	1	039520020
21	205	20,00	1	039520021
22	205	20,00	1	039520022
24	205	20,50	1	039520024



€	Icona	Icona
136,50	1	039520207
217,00	1	039520211

3953

chiave per pedali



mm	L mm	€	Icona	Icona
15	401	30,50	1	039530015

3955

chiavi a forchetta per serie sterzo universali



mm	L mm	€	Icona	Icona
30x32	292	28,50	1	039550108
32x36	319	31,50	1	039550114

39613,2

tiraggi nero 3,2mm



mm	€	Icona	Icona
3,2	11,00	1	039610032

39613,3

tiraggi verde 3,3 mm



mm	€	Icona	Icona
3,3	11,00	1	039610033

39613,5

tiraggi rosso 3,5 mm



mm	€	Icona	Icona
3,5	11,00	1	039610035

3961U

tiraggi professionale 3,2 - 4,0 mm



mm	€	Icona	Icona
3,2 - 4,0	18,00	1	039610100

3962SH

chiave tiraggi doppia per Shimano®



L mm	A1 mm	A2 mm	€	Icona	Icona
132	4,3	4,4	14,00	1	039620010

3962MV

chiave tiraggi doppia per Mavic®



L mm	A1 mm	A2 mm	€	Icona	Icona
135	4,3	8,4	14,50	1	039620020

3963P

chiave speciale per raggi piatti



L mm	€	Icona	Icona
129	6,60	1	039630010

3964

chiave speciale avvita nippli

• Dotato di molla di ricambio all'interno dell'impugnatura



L mm	L1 mm	€	Icona	Icona
170	89	16,40	1	039640010

3965

dima per campanatura ruote da 20" a 29"



L mm	€	Icona	Icona
680	80,00	1	039650010

3965C

centraruote professionale

• Per diametri da 20" a 29"
• Adattatore per assi passanti tra 10 e 20mm



L mm	L1 mm	A mm	€	Icona	Icona
500	380	285	324,00	1	039650110

3967

chiave frusta smonta-pignoni

• Compatibile fino a cassette da 11 velocità
• Manico in 2PVC
• Adatta anche per ruote a scatto fisso



L mm	€	Icona	Icona
289	44,50	1	039670010

3969

levagomme



L mm	A mm	€	Icona	Icona
200	15,6	8,00	1	039690010

3969K3

kit di 3 levagomme, in plastica



L mm	€	Icona	Icona
113	4,50	1	039690130

3971

chiave per vite in metallo Shimano®

• Adatto per guarniture Shimano® Hollowtech II



N°	mm	€	1	039710010
8	8	9,70		

3972

chiave estrattore per movimento centrale

• idoneo per Shimano® Hollowtech II, Campagnolo® Ultra-torque, FSA®, SRAM®



L	mm	€	1	039720010
252		19,00		

3973PF

estrattore per cuscinetti Press-Fit

• Adatto per diametri interni da 24 e 30mm



L	mm	€	1	039730001
240		25,00		

3973/1

chiave a bussola estrattore per movimento centrale a 16 tacche

• Idoneo per Shimano® XTR BB93, Dura-Ace® BB9000

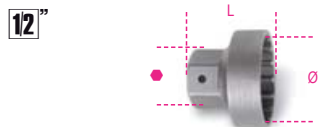

Ø	mm	mm	L	mm	€	1	039730010
39	24	34			16,30		

3973/2

chiave a bussola estrattore per movimento centrale a 16 tacche

• Idoneo per Shimano® BBR60 (Ultegra® 11 velocità)

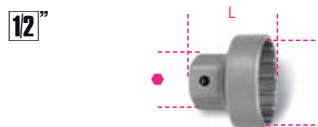

Ø	mm	mm	L	mm	€	1	039730020
41	24	35			16,30		

3973/3

chiave a bussola estrattore per movimento centrale a 16 tacche

• idoneo per Shimano® Hollowtech II, Campagnolo® Ultra-torque, FSA®, SRAM®

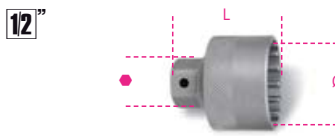

Ø int.	mm	mm	L	mm	€	1	039730030
46	24	53,5			16,30		

3973/4

chiave a bussola estrattore per movimento centrale a 20 tacche con perno centrale nichelata

• Idoneo per Shimano e ISIS



Ø	mm	L	mm	mm	€	1	039730040
31,5	55	24			10,20		

3975

pressa montaggio serie sterzo e movimento centrale

• Adatto per il montaggio delle calotte serie sterzo da 1", 1.1/8", 1.1/4", 1.1/2" e 2"

NOTE: non utilizzabile per calotte "zero stack"



L	mm	Ø	mm	€	1	039750010
360	16x1			215,00		

3984/1

chiave estrattore per ruote libere BMX a 4 innesti



Ø	mm	L	mm	mm	€	1	039840010
35	25,5	24			12,00		

3984/2

chiave estrattore per ruote libera Shimano®



Ø	mm	L	mm	mm	€	1	039840020
22,8	26	24			7,50		

3984/3

chiave estrattore per ruote libere Shimano® a cassetta con perno di guida

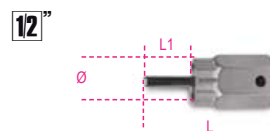

Ø	mm	L	mm	L1	mm	€	1	039840030
23,5	65	25			13,00			

3984/4

chiave estrattore per ruote libere Campagnolo con perno di guida



Ø	mm	L	mm	L1	mm	mm	€	1	039840040
23	51	13	24				17,00		

3984/5

chiave estrattore per ruote libere 2 innesti



Ø	mm	L	mm	mm	€	1	039840050
18,5	38	21			12,00		

3984/6

chiave estrattore per ruote libere 4 innesti



Ø	mm	L	mm	mm	€	1	039840060
19,5	36	21			12,00		

3991

leva per arretrare pastiglie freni a disco



L	mm	A	mm	α	°	€	1	039910010
222	36	7°				29,00		

3992

chiave per raddrizzare dischi freno



L	mm	A1	mm	€	1	039920010
234	4	55	2,2		21,50	

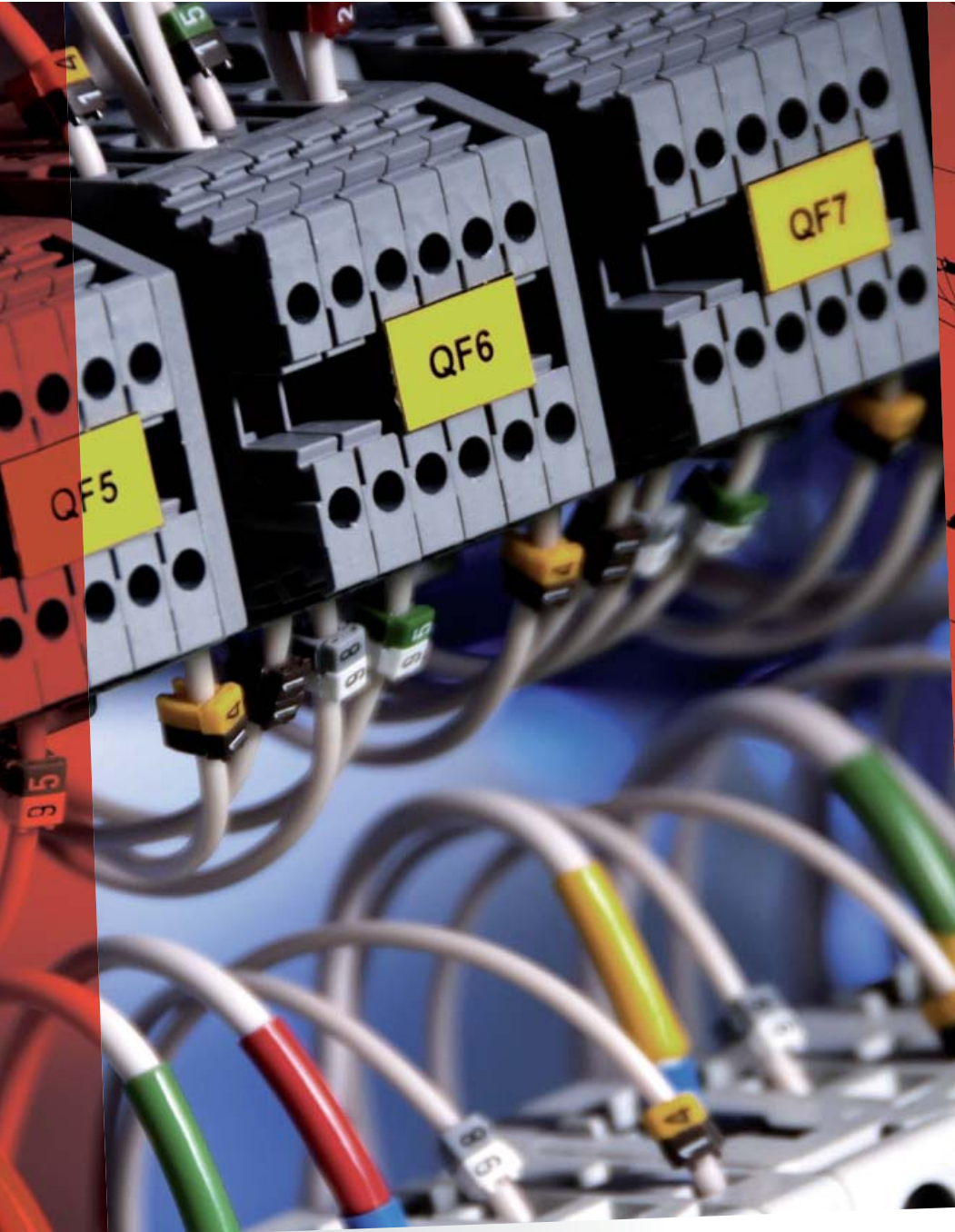

UTENSILI ISOLATI

Gli utensili isolati Beta sono prodotti studiati per garantire la sicurezza di installatori e manutentori elettrici. Tutti gli utensili isolati permettono di operare su impianti in tensione fino a 1000V in corrente alternata e 1500V in corrente continua. Per garantire il massimo livello di qualità e di prestazioni e accertare l'idoneità e la conformità alla norma EN 60900, ogni singolo utensile è sottoposto a un approfondito processo di verifica che comprende: prove di resistenza dell'impugnatura allo sfilamento e alla propagazione della fiamma e prova di tensione applicata a 10000 Volt. Per assortimenti e termoformati vedere le rispettive sezioni.



Istituto Italiano del Marchio di Qualità - I



Verband der Elektrotechnik
Elektronik Informationstechnik - D

⚠ 1000 V

TEST DI SICUREZZA: testati a 10.000 volt per lavorare su impianti a 1.000 volt

Gli utensili ad alto isolamento Beta vengono testati pezzo per pezzo a 10 kV, con l'obiettivo di offrire una qualità assoluta per strumenti di lavoro che devono garantire elevatissimi standard di sicurezza. Permettono infatti di operare su impianti in tensione fino a 1000 V in corrente alternata (1500 V in corrente continua).



NORME DI SICUREZZA:

Nonostante gli accuratissimi controlli in fase di produzione l'operatore deve sempre verificare, prima dell'uso, che non ci siano lacerazioni, modifiche o deterioramenti di qualsiasi tipo dell'impugnatura isolante.

Il mantenimento nel tempo delle caratteristiche dielettriche infatti è strettamente connesso agli stress meccanici, chimici o termici che possono venire imposti all'utensile.

Nel caso di deterioramenti dell'isolante, l'utensile non è da considerare sicuro per l'utilizzo su impianti in tensione. Usare sempre occhiali e guanti isolanti.

CONTROLLI ESEGUITI IN FASE DI PRODUZIONE



Controllo visivo al 100%:

tutti gli utensili devono avere finiture superficiali prive di difetti esteriormente visibili.

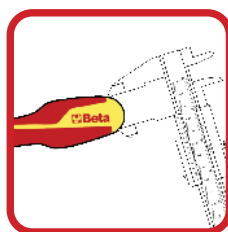

Controllo dimensionale:

tutte le quote caratteristiche degli utensili devono essere conformi alle specifiche di progetto.



Prova d'urto:

dopo un tempo di permanenza di 2 ore a -25°C l'utensile viene colpito per tre volte, (da un peso specifico determinato dalla norma) e non deve svilupparsi alcun danneggiamento dell'impugnatura isolante.



Prova di isolamento elettrico:

dopo un'immersione in acqua per 24 ore all'utensile viene applicata una tensione di 10 kV per 3 minuti. Non si devono verificare dispersioni di corrente superiori a quelli previsti dalla norma.



Prova di penetrazione:

viene applicato per due ore un peso di 2 kg sull'impugnatura dell'attrezzo a +70°C, successivamente nella zona sottoposta a pressione meccanica viene applicata una tensione di 5 kV per tre minuti. Non si devono verificare passaggi di corrente.

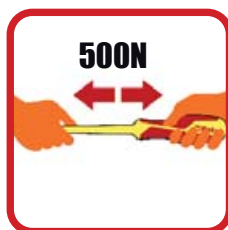

Prova di aderenza:

dopo un tempo di permanenza di 168 ore a +70°C all'utensile viene applicato un carico di 500 N per verificare che non si sfili l'impugnatura.

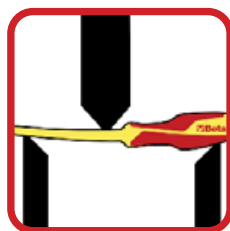

Prova meccanica:

gli utensili devono soddisfare tutte le prestazioni meccaniche stabilite dalle rispettive norme ISO di prodotto.

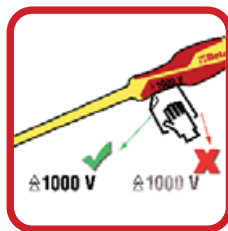

Prova di indelebilità delle marcature:

dopo il test di sfregamento con alcool isopropilico le marcature devono rimanere leggibili.



Prova di non propagazione della fiamma:

una fiamma viene indirizzata verso l'utensile per 10 secondi, nei 20 secondi successivi la fiamma non deve superare l'altezza di 120 mm.



52MQ

chiavi a forchetta semplici



EN 60900

mm	L mm	€	Icon	Icon
6	90	26,50	1	000520106
7	96	26,50	1	000520107
8	100	26,50	1	000520108
9	108	26,50	1	000520109
10	110	26,50	1	000520110
11	120	26,50	1	000520111
12	132	28,50	1	000520112
13	140	30,00	1	000520113
14	146	31,00	1	000520114
15	166	32,00	1	000520115
16	156	34,50	1	000520116
17	168	34,50	1	000520117
18	170	35,50	1	000520118
19	176	35,50	1	000520119
21	190	39,00	1	000520121
22	200	39,00	1	000520122
24	225	42,00	1	000520124
27	210	55,00	1	000520127
30	240	58,00	1	000520130
32	240	59,00	1	000520132

89MQ

chiavi poligonali semplici



EN 60900

mm	L mm	€	Icon	Icon
6	150	34,00	1	000890106
7	155	34,00	1	000890107
8	155	34,00	1	000890108
9	160	34,00	1	000890109
10	170	34,00	1	000890110
11	180	34,00	1	000890111
12	190	37,50	1	000890112
13	195	39,50	1	000890113
14	200	42,00	1	000890114
15	210	43,00	1	000890115
16	216	46,50	1	000890116
17	218	46,50	1	000890117
18	236	48,50	1	000890118
19	240	48,50	1	000890119
21	250	56,00	1	000890121
22	255	56,00	1	000890122
24	280	63,00	1	000890124
27	300	67,00	1	000890127
30	320	79,00	1	000890130
32	340	80,00	1	000890132

110MQ

chiave regolabile a rullino con scala graduata



EN 60900

L mm	A max	€	Icon	Icon
200	28	68,00	1	001100520
250	30	79,00	1	001100525
300	30	115,00	1	001100530

606MQ/50

chiave dinamometrica a scatto con cricchetto reversibile con sistema di trattenimento della bussola



EN 60900
UNI EN 26789
ISO 6789

Nm	Kgfm	lbf.ft	L1 mm	L mm	g
5÷50	0,5÷5	4÷40	90	375	1130

606MQ/50	€	Icon	Icon
	660,00	1	006060705

850MQ

portainseri magnetico isolato con impugnatura bimateriale



IMQ CSV
EN 60900

L mm	L1 mm	D mm	€	Icon	Icon
233	125	12,5	20,00	1	008500910

910MQ/B

chiavi a bussola poligonali



EN 60900

mm	L mm	Ø1 mm	Ø mm	€	Icon	Icon
6	45	14	24	24,50	1	009100616
7	45	15	24	24,50	1	009100617
8	45	16	24	24,50	1	009100618
9	45	17	24	24,50	1	009100619
10	45	19	24	24,50	1	009100620
11	45	20	24	24,50	1	009100621
12	45	24	24	24,50	1	009100622
13	45	24	24	24,50	1	009100623
14	45	25	24	24,50	1	009100624
15	45	27	24	26,00	1	009100625
16	45	27,5	24	26,00	1	009100626
17	45	30	24	26,50	1	009100627
18	45	31	24	26,50	1	009100628
19	45	32	24	26,50	1	009100629

910MQ/PE

chiavi a bussola maschio esagonale



EN 60900

mm	Ø mm	L mm	€	Icon	Icon
4	24	100	28,00	1	009100604
5	24,5	100	28,00	1	009100605
6	25,0	100	28,00	1	009100606
8	25,0	100	28,00	1	009100608
10	25,5	100	29,00	1	009100610

910MQ/TX

chiavi a bussola maschio per viti con impronta Torx®



EN 60900

mm	Ø mm	L mm	L1 mm	€	Icon	Icon
15	23	116	61	35,00	1	009100641
20	24,5	116	65	35,00	1	009100642
25	24,5	116	65	35,00	1	009100643
27	24,5	116	65	35,00	1	009100644
30	24,5	116	65	36,00	1	009100645
40	24,5	116	65	36,50	1	009100646

910MQ/XZN

chiavi a bussola maschio a profilo XZN®



EN 60900

mm	Ø mm	L mm	L1 mm	€	Icon	Icon
M8	24	106	57	33,00	1	009100658
M10	24	106	57	34,00	1	009100660

910MQ/PT

prolunghe pretrate con attacco quadro femmina 3/8"



EN 60900

Nm	L mm	L1 mm	€	Icon	Icon
12	80	35,5	185,00	1	009100801

910MQ/21

prolunga quadro maschio e femmina 3/8"



EN 60900

L mm	Ø mm	€	Icon	Icon
140	13,4	45,50	1	009100804

910MQ/22

prolunga quadro maschio e femmina 3/8"



EN 60900

L mm	Ø mm	€	Icon	Icon
265	13,4	48,50	1	009100805

910MQ/T

quadro maschio 3/8", a T



EN 60900					
L mm	L1 mm	€			
200	165	53,50	1	009100807	

910MQ/55

cricchetto reversibile con attacco quadro maschio 3/8"



EN 60900					
L mm	D mm	A mm	€		
203	41	67	152,00	1	009100808

910MQ/C16

8 chiavi a bussola poligonali
4 chiavi a bussola esagonali maschio
e 4 accessori



EN 60900					
910MQ/C16		€			
		656,00	1	009100917	

- 910MQ/B 8 - 10 - 11 - 12 - 13 - 14 - 17 - 19 mm
- 910MQ/PE 4 - 5 - 6 - 8 mm
- 910MQ/21 125 mm
- 910MQ/22 250 mm
- 910MQ/T
- 910MQ/55

914MQ/A

chiavi a bussola esagonali, con attacco quadro femmina 3/8", in tecnopolimeri speciali su base poliammidica.

Specifiche per operare su batterie di auto ibride ed elettriche



EN 60900					
mm	mm	L mm	Ø1 mm	€	
8	17,5	45	20	12,50	2 009140008
10	20,5	45	20	12,50	2 009140010
13	24	45	20	12,50	2 009140013
17	30	45	22	12,50	2 009140017

3/8"



EN 60900

914MQ-A/S4	€			
8-10-13-17 mm	50,00	1	009140054	

920MQ/A

chiavi a bussola esagonali



EN 60900

mm	Ø mm	L mm	Ø1 mm	€	
8	21,5	57	27,5	24,50	1 009200238
9	21,5	57	27,5	24,50	1 009200239
10	21,5	57	27,5	24,50	1 009200240
11	21,5	57	27,5	24,50	1 009200241
12	23,0	57	27,5	24,50	1 009200242
13	23,0	57	27,5	24,50	1 009200243
14	23,0	57	27,5	25,50	1 009200244
16	23,0	57	27,5	26,00	1 009200246
17	30,0	57	27,5	26,00	1 009200247
18	32,0	57	27,5	26,50	1 009200248
19	32,2	57	27,5	26,50	1 009200249
20	32,0	57	27,5	30,00	1 009200250
21	34,0	57	27,5	30,00	1 009200251
22	36,0	57	27,5	30,00	1 009200252
24	39,0	57	27,5	31,00	1 009200254
27	42,0	57	27,5	31,50	1 009200257
30	44,0	57	27,5	32,50	1 009200260
32	48,0	57	27,5	33,50	1 009200262

920MQ/PE

chiavi a bussola maschio esagonale



EN 60900

mm	Ø mm	L mm	L1 mm	€	
*4	28,5	94,50	10,5	41,50	1 009200264
*5	28,5	94,5	10,5	41,50	1 009200265
*6	28,5	94,5	10,5	41,50	1 009200266
*8	28,5	94,5	10,5	41,50	1 009200268
10	28,5	94,5	10,5	43,50	1 009200267
12	28,5	94,5	10,5	43,50	1 009200269

920MQ/21

prolunga quadro maschio e femmina 1/2"



EN 60900

L mm	Ø mm	€		
135	28	47,50	1	009200804

920MQ/22

prolunga quadro maschio e femmina 1/2"



EN 60900

L mm	Ø mm	€		
264	30	54,50	1	009200805

920MQ/T

quadro maschio 1/2", a T



EN 60900

L mm	L1 mm	€		
200	163	57,50	1	009200807

920MQ/55A

cricchetto reversibile con attacco quadro maschio 1/2" con sistema di bloccaggio bussola



EN 60900

L mm	D mm	A mm	€	
240	50	89	203,00	1 009200809

920MQ/C16

9 chiavi a bussola esagonali
3 chiavi a bussola esagonali maschio
e 4 accessori



EN 60900

920MQ/C16	€			
	769,00	1	009200917	

- 920MQ/A 8 - 10 - 12 - 13 - 14 - 17 - 19 - 22 - 24 mm
 - 920MQ/PE 5 - 6 - 8 mm
 - 920MQ/21 135 mm
 - 920MQ/22 264 mm
 - 920MQ/55A
 - 920MQ/T
- 420x280x60 mm - 5,2 kg

943MQ

chiavi a bussola esagonale con impugnatura



EN 60900

mm	L mm	L1 mm	D mm	€		
5,5	233	125	12,2	15,80	1	009430235
6	233	125	12,5	15,80	1	009430236
7	240	125	14,3	16,80	1	009430237
8	240	125	15,3	17,30	1	009430238
10	252	125	17,3	17,80	1	009430240
13	252	125	21,3	19,50	1	009430243

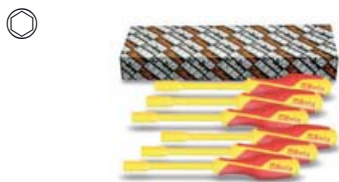

943MQ/S6 € 103,00 1 009430250
5,5-6-7-8-10-13 mm

951MQ

chiavi a T maschio esagonale



EN 60900

mm	L mm	L1 mm	€		
3	120	105	39,50	1	009510703
4	165	105	40,50	1	009510704
5	170	105	40,50	1	009510705
6	168	105	40,50	1	009510706
8	165	105	41,50	1	009510708
10	200	105	43,50	1	009510710

993MQ

pinzetta a molla a punte curve arrotondate, zigrinate



EN 60900

L mm € 33,50 1 009930040
147

994MQ

pinzetta a molla a punte diritte arrotondate, zigrinate



EN 60900

L mm € 32,50 1 009940040
145

1010MQ

pinze a becchi tonde lunghi



EN 60900

L mm L1 mm € 40,00 1 010100096
160 51,5

1048MQ

pinze regolabili a cerniera chiusa

• Finitura cromata



EN60900

L mm A max mm L1 mm € 59,50 1 010480315
250 48 39

1082MQ

tronchesi a taglienti diagonali



EN 60900

L mm L1 mm mm € 39,50 1 010820094
140 20 1,6

L mm L1 mm mm € 41,50 1 010820096
160 22 1,6

1084MQ

tronchesi a grande effetto a taglienti diagonali



EN 60900

L mm L1 mm mm € 52,50 1 010840100
200 26 2,0

1088MQ

tronchesi a taglienti frontali



EN 60900

L mm L1 mm mm € 49,00 1 010880096
160 7 1,6

2115P L-MQ32



2115PL-MQ32

320

1128MQ

forbici per elettricisti lame in acciaio inossidabile con microdentatura



IEC60900

L mm L1 mm € 41,50 1 011280101
145 45

1132MQ

tagliacavi per cavi flessibili in rame e alluminio

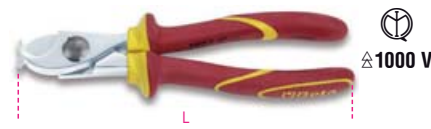

EN 60900

L mm mm € 75,50 1 011320193
230 18

1142MQ

pinza spellafili



EN 60900

L mm mm² € 44,50 1 011420096
160 0,5÷6

1150MQ

pinze universali cromate



EN 60900

L mm	L1 mm	mm	€		
160	37	1,6	38,00	1	011500096
180	39	1,8	41,00	1	011500098
200	43	2,0	43,50	1	011500100
220	46	2,0	47,00	1	011500102

1162MQ

pinze a becchi piatti
lunghe e diritte



EN 60900

L mm	L1 mm	mm	€	Icon	Icon
160	56	1,6	40,50	1	011620096
200	76	1,6	43,50	1	011620100

1164MQ

pinze a becchi piatti
lunghe e piegate

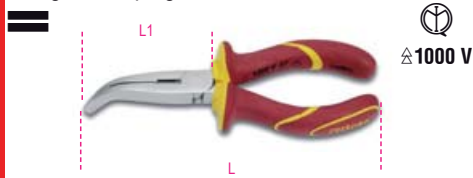

L mm	L1 mm	mm	€	Icon	Icon
160	54	1,6	42,50	1	011640096
200	76	1,6	45,50	1	011640100

1166MQ

pinze a becchi mezzotondi
lunghe e diritte



EN 60900

L mm	L1 mm	mm	€	Icon	Icon
160	56	1,6	40,50	1	011660096
200	76	1,6	43,50	1	011660100

1168MQ

pinze a becchi mezzotondi
lunghe e piegate



EN 60900

L mm	L1 mm	mm	€	Icon	Icon
160	50	1,6	42,50	1	011680096
200	70	1,6	45,50	1	011680100

1272MQ/F

giravite per viti con impronta a croce Phillips®

Slim

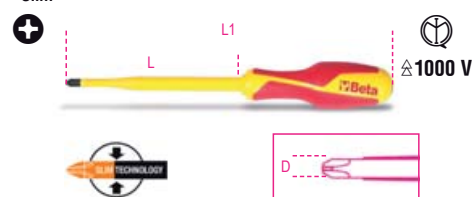

EN60900

PHxDxL mm	L1 mm	€	Icon	Icon
1x4,5x80	187	10,70	3	012720409
2x6x100	218	12,20	3	012720418

1272MQ

giravite per viti con impronta
a croce Phillips®



EN 60900

PHxDxL mm	L1 mm	€	Icon	Icon
0x3x60	160	8,00	3	012720703
1x4,5x80	187	9,70	3	012720709
2x6x100	218	11,30	3	012720718
3x8x150	276	14,50	2	012720724
4x10x200	326	17,30	2	012720727



1272MQ/S5	€	Icon	Icon
PH0x3x60-PH1x4,5x80 PH2x6x100-PH3x8x150 PH4x10x200 mm	61,00	1	012720751

1273MQ/F-D6

serie di 6 giravite slim



1273MQ/F-D6	€	Icon	Icon
1274MQ/F 0,5x3,5x100 - 0,8x4,5x100 - 1x5,5x125 - 1,2x6,5x150 mm	66,00	1	012730406
1272MQ/F PH1x4,5x80- PH2x6x100 mm			

1273MQ/D6

serie di 6 giravite



1273MQ/D6	€	Icon	Icon
1274MQ 0,5x3x100 - 0,8x4x100 1,0x5,5x125 mm	57,00	1	012730851
1272MQ PH0x3x60 - PH1x4,5x80 PH2x6x100 mm			

1274MQ/F

giravite per viti senza testa con intaglio

Slim

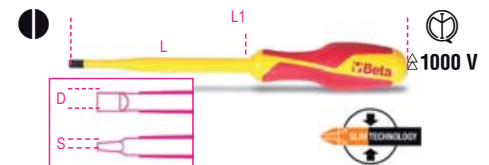

EN60900

SxDxLmm	L1 mm	€	Icon	Icon
0,6x3,5x100	200	8,90	3	012740403
1x4,5x100	205	10,00	3	012740406
1x5,5x125	232	11,10	3	012740409
1,2x6,5x150	268	13,00	3	012740412

1274MQ

giravite per viti senza testa
con intaglio

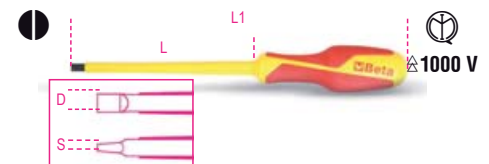

EN 60900

SxDxL mm	L1 mm	€	Icon	Icon
0,4x2,5x75	175	7,80	3	012740700
0,5x3x100	200	8,20	3	012740703
0,8x4x100	207	9,50	3	012740706
1x5,5x125	232	10,30	3	012740709
1,2x6,5x150	268	12,40	3	012740712
1,2x8x175	301	14,50	2	012740715
1,6x10x200	326	17,20	2	012740718



1274MQ/S6	€	Icon	Icon
0,5x3x100-0,8x4x100 1x5,5x125-1,2x6,5x150 1,2x8x175-1,6x10x200 mm	72,00	1	012740751

1275MQ/C

giravite per viti a croce combinata PH +
intaglio

Slim

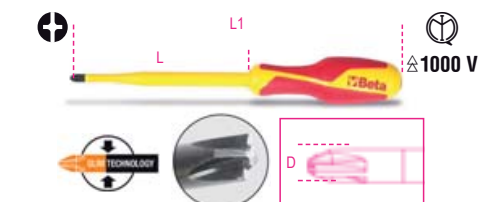

EN60900

Icon	Icon	€	Icon	Icon
PH1+LPP		11,00	2	012750409
PH2+LPP		12,40	2	012750418

1276MQ/C

giravite per viti a croce combinata PZ + intaglio

Slim

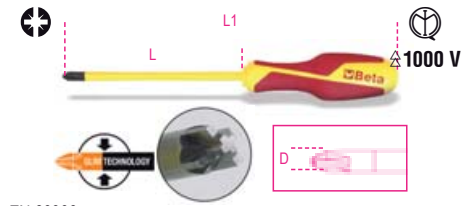

EN 60900

☉ PZ1+LPP	€ 11,00	2	012760409
☉ PZ2+LPP	€ 12,40	2	012760418

1279MQ/F

giravite per viti con impronta a croce Pozidriv®-Supadriv®

Slim

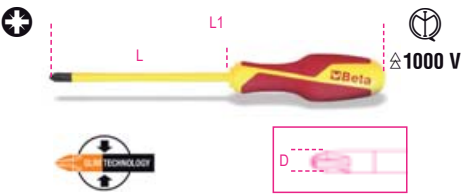

EN60900

pz	L mm	L1 mm	€	QTY	Code
1	80	187	11,00	3	012790409
2	100	218	12,40	3	012790418

1279MQ

giravite per viti con impronta a croce Pozidriv®-Supadriv®



EN 60900

PZ	L mm	L1 mm	€	QTY	Code
0	60	160	8,30	3	012790703
1	80	187	9,90	3	012790709
2	100	218	11,50	3	012790718
3	150	276	15,00	2	012790724



1279MQ/S4	€ 44,50	1	012790751
-----------	---------	---	-----------

1725MQ

miniseghetto



EN 60900

1725MQ	L mm 260	H mm 85	€ 75,50	1	017250030
--------	----------	---------	---------	---	-----------

1777MQ/C

coltello spellacavi isolato

per cavi multipolari



EN 60900

1777MQ/C	L mm 190	€ 31,00	1	017770026
----------	----------	---------	---	-----------

1777MQ/U

coltello spellacavi isolato

per cavi unipolari



EN 60900

1777MQ/U	L mm 190	€ 28,00	1	017770011
----------	----------	---------	---	-----------

1777RL/U

4 lame di ricambio per cutter 1777MQ/U



1777RL/U	€ 22,30	1	017770021
----------	---------	---	-----------

1995MQ/T

tappeto isolante

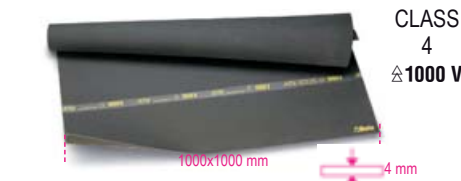

VDE 0303
EN 60243

1995MQ/T	LxSxH mm 1000x1000	€ 255,00	1	019950030
----------	--------------------	----------	---	-----------

1995MQ/G1 - G2

guanti isolanti, in lattice



EN 60903

1995MQ/G1	Gr. 9	L mm 410	€ 102,00	1	019950010
1995MQ/G2	10	410	102,00	1	019950013

1996MQ/T

telo isolante

500x500mm

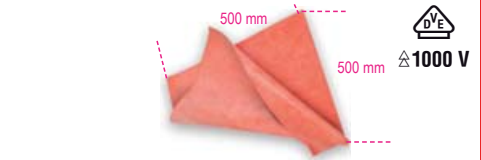

DIN EN 61112

S mm 0.5	€ 77,00	1	019960005
----------	---------	---	-----------

1996MQ/GM

guanti isolanti composti



EN 60903
EN 61482

1996MQ/GM 9	Gr. 9	L mm 410	€ 130,00	1	019960109
1996MQ/GM 10	10	410	130,00	1	019960110

1996SVG

strumento per la verifica pneumatica dei guanti isolati
obbligatoria per la EN90603



1996SVG	€ 298,00	1	019960133
---------	----------	---	-----------





UTENSILI ANTICADUTA

Beta H-SAFE

La gamma di utensili H-SAFE di Beta comprende più di 200 referenze, per le quali è stato progettato individualmente un sistema di trattenimento in grado di resistere alle più severe sollecitazioni meccaniche come garanzia di massima sicurezza.

Anche il confort nell'utilizzo è importante, infatti gli utensili con doppia parte attiva, come la chiave di manovra art.42, sono allacciati con un cavo che può scorrere lungo tutto il corpo dell'utensile, mentre gli utensili manovrati con torsione, ad esempio il giravite, sono allacciati con anelli a rotazione libera per non indurre attorcigliamenti nel laccio.



Il sistema di trattenimento H-SAFE è stato ideato, testato e prodotto negli stabilimenti Beta. Col sistema di sicurezza H-SAFE di Beta gli utensili sono sempre a portata di mano in modo confortevole e sicuro.

35HS

scalpelli nervati
con sistema anticaduta H-SAFE



L mm	A mm	€		
200	23,0	32,50	1	000354004
250	28,5	40,50	1	000354005

42NEWHS

chiavi combinate
con sistema anticaduta H-SAFE



DIN 3113 UNI-ISO 7738

mm	L mm	€		
6x6	95	16,80	1	000424506
7x7	105	17,00	1	000424507
8x8	116	17,20	1	000424508
9x9	127	17,60	1	000424509
10x10	137	17,80	1	000424510
11x11	148	18,30	1	000424511
12x12	158	18,50	1	000424512
13x13	169	18,80	1	000424513
14x14	180	19,50	1	000424514
15x15	190	20,00	1	000424515
16x16	201	20,50	1	000424516
17x17	212	21,50	1	000424517
18x18	222	22,00	1	000424518
19x19	233	22,50	1	000424519
20x20	243	23,50	1	000424520
21x21	254	24,50	1	000424521
22x22	264	25,00	1	000424522
23x23	275	26,00	1	000424523
24x24	285	27,50	1	000424524
25x25	296	28,00	1	000424525
26x26	307	29,00	1	000424526
27x27	317	31,00	1	000424527
28x28	328	31,50	1	000424528
29x29	338	34,00	1	000424529
30x30	349	35,00	1	000424530
32x32	370	39,00	1	000424532
34x34	391	63,50	1	000424534
36x36	412	70,00	1	000424536

42HS/AS

chiavi combinate
con sistema anticaduta H-SAFE



"	L mm	€		
1/4x1/4	95	18,00	1	000424106
5/16x5/16	116	18,20	1	000424108
3/8x3/8	137	19,20	1	000424110
7/16x7/16	148	19,90	1	000424111
1/2x1/2	169	20,00	1	000424113
9/16x9/16	180	20,30	1	000424114
5/8x5/8	201	22,00	1	000424116
11/16x11/16	212	23,00	1	000424117
3/4x3/4	233	24,00	1	000424119
13/16x13/16	254	27,00	1	000424121

"	L mm	€		
7/8x7/8	264	27,50	1	000424122
15/16x15/16	285	30,50	1	000424124
1x1	296	31,50	1	000424125
1.1/16x1.1/16	317	34,00	1	000424127
1.1/8x1.1/8	338	36,00	1	000424129
1.1/4x1.1/4	370	43,00	1	000424132
1.5/16x1.5/16	391	65,00	1	000424133

55HS

chiavi a forchetta doppie
con sistema anticaduta H-SAFE



UNI-ISO 10102 DIN 3110

mm	L mm	€		
6x7	120	13,40	1	000554012
8x9	140	13,70	1	000554021
10x11	155	14,00	1	000554030
12x13	170	15,00	1	000554042
14x15	185	15,50	1	000554054
16x17	202	16,50	1	000554060
18x19	220	17,50	1	000554066
20x22	236	18,50	1	000554075
21x23	245	19,50	1	000554078
22x24	245	21,00	1	000554081
24x27	262	23,00	1	000554090
30x32	297	29,00	1	000554108
34x36	325	64,00	1	000554117

91HS-C

chiavi poligonali curve con leva di manovra

con sistema anticaduta H-SAFE



mm	Ø mm	€		
36	54	78,50	1	000914036
41	62	91,50	1	000914041
46	69	106,00	1	000914046

effettuare il cambio utensile (bussolle, chiavi o lame)
esclusivamente a terra

91HS

chiavi poligonali curve

con sistema anticaduta H-SAFE



mm	Ø mm	€		
36	54	156,50	1	000914236
41	62	169,50	1	000914241
46	69	200,00	1	000914246

effettuare il cambio utensile (bussolle, chiavi o lame)
esclusivamente a terra

92HS

leve di manovra per art. 91HS
con sistema di anticaduta H-SAFE



L mm	91 mm	Ø mm	€	
610	32=41	22	78,00	1 000924020
760	46=55	25	94,00	1 000924030

93HS

chiave per ponteggi
con sistema anticaduta H-SAFE



mm	L mm	€		
21x22	310	46,00	1	000934021

96THS

chiavi maschio esagonale piegate
con impugnatura di manovra
con sistema anticaduta H-SAFE

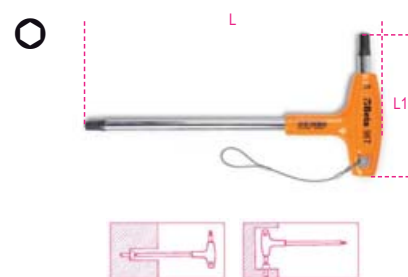

mm	L mm	L1 mm	€	
2,5	153	55	20,50	1 000964935
3	153	55	21,00	1 000964936
4	179	70	21,50	1 000964938
5	200	84	22,00	1 000964940
6	221	103	23,50	1 000964941
8	255	117	27,50	1 000964943
10	285	132	30,00	1 000964945

96THS-AS

chiavi maschio esagonale piegate
con impugnatura di manovra
con sistema anticaduta H-SAFE

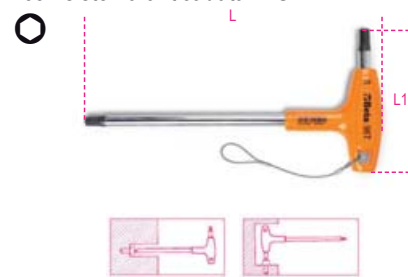

"	L mm	L1 mm	Ø mm	€	
5/32	200	84	6	23,50	1 000964673
3/16	200	84	6	23,50	1 000964674
7/32	221	103	7	25,50	1 000964675
1/4	236	106	8	26,50	1 000964676
5/16	255	117	10	29,00	1 000964678
3/8	285	132	12	32,00	1 000964680

97TTKHS

chiavi maschio piegate
con impugnatura
per viti con impronta Torx®

con sistema anticaduta H-SAFE

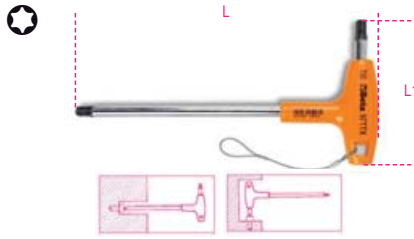

Ø	L mm	L1 mm	€	🔧	📦
T10	179	70	21,00	1	000974710
T15	179	70	21,50	1	000974715
T20	179	70	22,00	1	000974720
T25	179	70	22,50	1	000974725
T30	200	84	25,00	1	000974730
T40	221	103	27,00	1	000974740
T45	236	106	29,50	1	000974745
T50	255	117	35,50	1	000974750

111HS

chiavi regolabili a rullino cromate con scala graduata

con sistema anticaduta H-SAFE

- Rotazione destrorsa del rullino
- Scala millimetrata e in pollici



DIN 3117 ISO 6787

L mm	L' mm	A max mm	A1 mm	€	🔧	📦
200	8	28	62,0	39,50	1	001114020
250	10	34	70,0	45,50	1	001114025
300	12	35	84,0	55,50	1	001114030
380	15	45	97,0	95,00	1	001114038
450	18	54	115,0	150,00	1	001114045

142HS

chiavi combinate a cricchetto reversibile

con sistema anticaduta H-SAFE



Ø mm	L mm	€	🔧	📦
8x8	136	26,00	1	001424008
9x9	143	27,00	1	001424009
10x10	159	27,50	1	001424010
11x11	168	28,00	1	001424011
12x12	174	28,50	1	001424012
13x13	180	29,50	1	001424013
14x14	190	30,00	1	001424014
15x15	200	31,50	1	001424015
16x16	216	33,50	1	001424016
17x17	233	34,00	1	001424017
18x18	239	36,00	1	001424018
19x19	248	36,50	1	001424019
21x21	285	44,00	1	001424021
22x22	285	45,00	1	001424022
24x24	325	51,50	1	001424024
27x27	355	68,50	1	001424027
30x30	420	79,00	1	001424030
* 32x32	420	82,00	1	001424032

* modello diritto senza invertitore

360HS

giratubi modello Stillson

con sistema anticaduta H-SAFE



L mm	Ø max " gas	€	🔧	📦
250	1" gas	42,50	1	003604025
350	1 1/2" gas	53,00	1	003604035
450	2" gas	68,00	1	003604045
600	2 1/2" gas	97,00	1	003604060

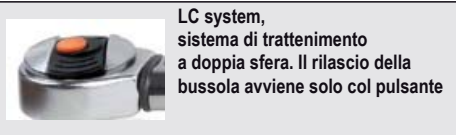

LC system,
sistema di trattenimento
a doppia sfera. Il rilascio della
bussola avviene solo col pulsante

666HS

Chiavi dinamometriche a scatto
con cricchetto reversibile
per serraggi destrorsi
precisione di serraggio ± 3%

con sistema anticaduta H-SAFE



ISO 6789

Nm	Kgfm	lbf.ft	■	D mm	A mm	L mm	g
10÷50	1÷5	7÷37	3/8	30	33	312	660

666HS/5 222,00 1 006664005

Nm	Kgfm	lbf.ft	■	D mm	A mm	L mm	g
20÷100	2÷10	15÷75	3/8	30	33	381	730

666HS/10 225,00 1 006664010

Nm	Kgfm	lbf.ft	■	D mm	A mm	L mm	LC system	g
40÷200	4÷20	30÷150	1/2	40	43	470	*	1010

666HS/20LC 255,00 1 006664021

Nm	Kgfm	lbf.ft	■	D mm	A mm	L mm	LC system	g
60÷300	6÷30	50÷220	1/2	40	43	598	*	1380

666HS/30LC 285,00 1 006664031

900E-HS/55

cricchetti reversibili

con sistema anticaduta H-SAFE



DIN 3122 - UNI-ISO 3315

L mm	Ø mm	A mm	■	€	🔧	📦
125	25	18	1/4	40,50	1	009004880

910E-HS/55

cricchetti reversibili

con sistema anticaduta H-SAFE

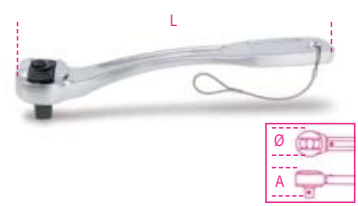

DIN 3122 - UNI-ISO 3315

L mm	Ø mm	A mm	■	€	🔧	📦
200	30	33	3/8	46,00	1	009104880

920E-HS/55LC

cricchetti reversibili "LC System" con sistema anticaduta H-SAFE

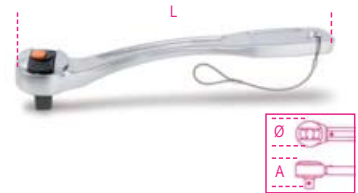

DIN 3122 - UNI-ISO 3315

L mm	Ø mm	A mm	■	€	🔧	📦
275	40	43	1/2	67,00	1	009204880

932HS

chiavi a pipa doppie
esagonali-poligonali
cromate lucide

con sistema anticaduta H-SAFE

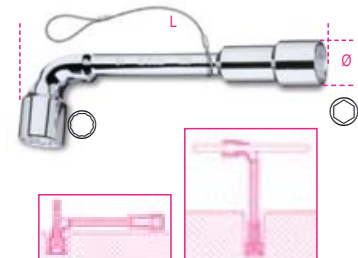

NF E 74.303

Ø mm	Ø mm	L mm	€	🔧	📦
6x6	11,5	110	22,50	1	009324006
7x7	12,5	116	23,00	1	009324007
8x8	13,0	120	24,00	1	009324008
9x9	14,0	125	24,50	1	009324009
10x10	16,5	133	25,00	1	009324010
11x11	17,5	143	26,50	1	009324011
12x12	19,0	148	27,50	1	009324012
13x13	19,5	154	28,00	1	009324013
14x14	21,5	167	30,00	1	009324014
15x15	22,5	182	30,50	1	009324015
16x16	24,5	193	31,50	1	009324016
17x17	26,0	198	32,00	1	009324017
18x18	26,5	215	34,00	1	009324018
19x19	29,0	220	36,00	1	009324019

1032HS

pinze a becchi dritti
per anelli elastici di sicurezza, per fori
manici ricoperti in PVC

con sistema anticaduta H-SAFE



UNI 7914 DIN 5256

L	∅	∅1	A	€		
mm	mm	mm	mm			
140x1,3	12=25	1,3	20	31,00	1	010324014
180	19=60	1,9	21	32,50	1	010324017

1034HS

pinze a becchi piegati a 90°
per anelli elastici di sicurezza, per fori
manici ricoperti in PVC

con sistema anticaduta H-SAFE



UNI 7914 DIN 5256

L	∅	∅1	A	€		
mm	mm	mm	mm			
170	19=60	1,9	21	34,50	1	010344017

1036HS

pinze a becchi dritti
per anelli elastici di sicurezza per alberi
manici ricoperti in PVC

con sistema anticaduta H-SAFE



UNI 7915 DIN 5254

L	∅	∅1	A	€		
mm	mm	mm	mm			
140x1,3	10=25	1,3	20	32,50	1	010364014
175	19=60	1,9	21	33,50	1	010364017

1038HS

pinze a becchi piegati a 90°
per anelli elastici di sicurezza per alberi
manici ricoperti in PVC

con sistema anticaduta H-SAFE



UNI 7915 DIN 5254

L	∅	∅1	A	€		
mm	mm	mm	mm			
175	19=60	-	21	35,50	1	010384017

1048BM-HS

pinza regolabile a cerniera chiusa,
impugnatura bimatereale

con sistema anticaduta H-SAFE

· modello a nove posizioni

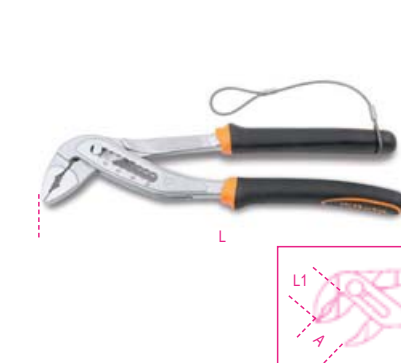

ISO 8976

L	A max	L1	g	€		
mm	mm	mm	g			
250	48	39	460	51,00	1	010484215

1052HS

pinze regolabili autobloccanti
ganasse concave

con sistema anticaduta H-SAFE

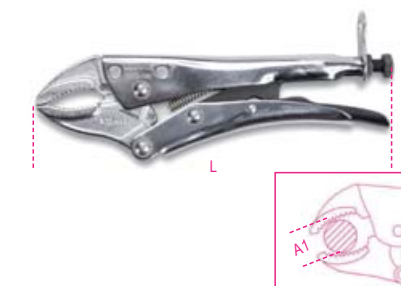

L	A	A1 max	S	€		
mm	mm	mm	mm			
240	72	42	10,0	42,00	1	010524024

1082BM-HS

tronchesi a taglianti diagonali
impugnatura bimatereale

con sistema anticaduta H-SAFE



UNI/ISO 5749

L	L1	∅	A	€		
mm	mm	mm	mm			
160	22	1,6	28,0	41,00	1	010824036

1088BM-HS

tronchesi a grande effetto
a taglianti frontali
impugnatura bimatereale

con sistema anticaduta H-SAFE

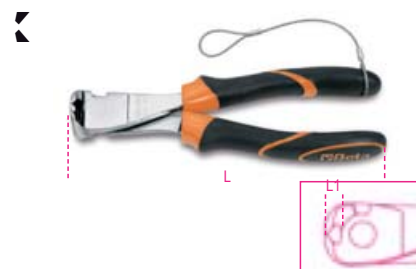

UNI/ISO 5748

L	L1	∅	A	€		
mm	mm	mm	mm			
160	9	1,6	28,0	47,50	1	010884036
200	11	2,0	36,0	60,00	1	010884040

1128BAX-HS

forbici per elettricisti a doppio effetto,
con profili a fresa in acciaio inossidabile
rivestito in DLC

con sistema anticaduta H-SAFE

taglio a doppio effetto: attraverso una speciale camma sul fulcro si ottiene uno scorrimento longitudinale delle lame che, nella fase di chiusura, ne aumenta la potenza di taglio.

profilo e fresa: studiate per allargare fori su plastica da 13 a 25 mm.

rivestimento DLC: Il DLC (diamond-like carbon) è un rivestimento innovativo a base di carbonio: l'elevata durezza ed il basso coefficiente d'attrito nascono dalla simultanea presenza di carbonio depositato sulla superficie in forma di grafite e diamante.

- alta durezza superficiale delle lame (resistenza all'abrasione e mantenimento dell'affilatura nel tempo)
- basso coefficiente di attrito (scorrevolezza e potenza di taglio)
- perno eccentrico antiallentamento
- manici ampi con gole strozzatubi



L	L1	∅	€		
mm	mm	mm	€		
150	50	50	39,50	1	011284088

1132BM-HS

tagliacavi
impugnatura bimatereale
per cavi isolati in rame e alluminio

con sistema anticaduta H-SAFE



UNI 8791

L	∅	A	B	€		
mm	mm	mm	mm			
230	18	37	12,5	72,50	1	011324143

1150BM-HS

pinze universali a grande effetto, cromate, impugnatura bimatériale

con sistema anticaduta H-SAFE

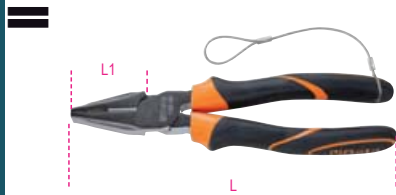

ISO 5746

L mm	L1 mm	Ø mm	A mm	€	Icon	Icon
160	42	1,6	22,0	36,00	1	011504146
180	46	1,8	25,0	38,00	1	011504148
200	50	2,0	27,0	41,00	1	011504150

1166BM-HS

pinze a becchi mezzotondi lunghissimi diritti zigrinati impugnatura bimatériale

con sistema anticaduta H-SAFE



ISO 5745

L mm	L1 mm	Ø mm	A mm	€	Icon	Icon
200	76	1,6	22,0	42,50	1	011664040

1168BM-HS

pinze a becchi mezzotondi lunghissimi piegati zigrinati impugnatura bimatériale

con sistema anticaduta H-SAFE



ISO 5745

L mm	L1 mm	Ø mm	A mm	€	Icon	Icon
200	70	1,6	22,0	45,50	1	011684040



1290HS

giravite per viti a testa con intaglio

con sistema anticaduta H-SAFE



ISO 2380

SxAxL mm	L1 mm	Ø mm	€	Icon	Icon
0,4x2,5x75	171	2,5	14,70	1	012904006
0,5x3x100	196	3,0	15,20	1	012904012
0,6x3,5x100	196	3,5	16,30	1	012904021
0,8x4x100	196	4,0	15,90	1	012904030
0,8x4x150	246	4,0	17,00	1	012904036
1x5,5x150	259	5,0	19,00	1	012904042
1,2x6,5x150	270	6,0	20,10	1	012904051
1,2x8x150	282	7,0	22,60	1	012904057
1,6x10x200	332	8,0	26,00	1	012904066

1292HS

giravite per viti con impronta a croce Phillips® H-SAFE

con sistema anticaduta H-SAFE



UNI/ISO 8764

PHxDxL mm	L1 mm	€	Icon	Icon
0x3x100	196	15,40	1	012924006
1x4,5x120	229	17,10	1	012924012
2x6x150	270	20,70	1	012924021
3x8x150	282	23,70	1	012924024

1294HS

giravite per viti senza testa con intaglio

con sistema anticaduta H-SAFE



SxDxL mm	L1 mm	€	Icon	Icon
0,5x2,5x60	156	14,30	1	012944003
0,6x3x75	171	14,50	1	012944006
0,8x4x100	196	16,00	1	012944012
1x5x125	234	18,60	1	012944018

1299HS

giravite per viti con impronta a croce Pozidriv®-Supadriv®

con sistema anticaduta H-SAFE



UNI/ISO 8764

PZ	L mm	L1 mm	€	Icon	Icon
0	60	156	16,20	1	012994000
1	80	189	18,00	1	012994003
2	100	220	22,50	1	012994006
3	150	282	28,00	1	012994009

1370T-HS

martelli tipo tedesco per meccanici manico in fibra

con sistema anticaduta H-SAFE



g	A mm	L mm	L1 mm	€	Icon	Icon
300	23	300	105	31,00	1	013704630
500	27	320	118	33,00	1	013704650
1000	36	360	135	41,00	1	013704700

1370FT-HS

martelli tipo francese per meccanici, manico in fibra

con sistema anticaduta H-SAFE



A mm	L mm	L1 mm	B mm	€	Icon	Icon
28	280	86	22	42,00	1	013704528
30	280	92	24	42,50	1	013704530
36	300	104	29	50,00	1	013704536

1390HS

mazzuole con battenti intercambiabili in materiale plastico manico in legno

con sistema anticaduta H-SAFE



UNI 7784

D mm	L mm	L1 mm	€	Icon	Icon
35	310	95	39,00	1	013904035
45	320	107	55,00	1	013904045

1392HS

mazzuole antirimbalo
con battenti intercambiabili
in materiale plastico
manico in acciaio

con sistema anticaduta H-SAFE



D mm	L mm	L1 mm	€	📦	🖨️
35	305	115	56,00	1	013924035
40	310	125	62,50	1	013924040
50	325	135	73,00	1	013924050
60	385	155	106,00	1	013924060

1602A-HS

pinza per capicorda preisolati
modello standard

con sistema anticaduta H-SAFE

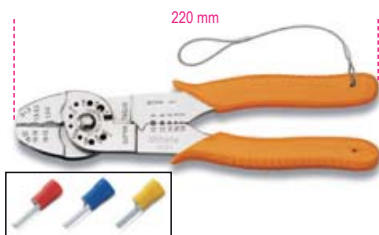

📏	L mm	A mm	B mm	€	📦	🖨️
0÷6 mm²	220	42	4	60,00	1	016024005

1682HS

righe flessibili graduate
in acciaio inossidabile

con sistema anticaduta H-SAFE

- doppia scala millimetrata
- antiriflesso

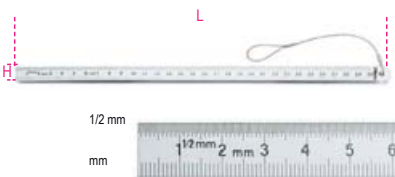

L mm	H mm	± mm	€	📦	🖨️
200	13	0,5	13,40	1	016824020
300	13	0,5	15,00	1	016824030

1692HS

flessometri
cassa bimerale in ABS antiurto
nastro in acciaio
classe di precisione II

con sistema anticaduta H-SAFE



L m	S mm	€	📦	🖨️
3	16	18,00	1	016924053
5	19	21,50	1	016924055

1708HS/20

spessimetri

con sistema anticaduta H-SAFE



S mm	S mm	L mm	€	📦	🖨️
0,05÷1,0	0,002÷0,040	105	20,00	1	017084020

1727HS

seghetto tipo pesante

con sistema anticaduta H-SAFE



L mm	L1 mm	€	📦	🖨️
515	300	27,50	1	017274001

1743HS

pinza per fascette in Nylon

con sistema anticaduta H-SAFE

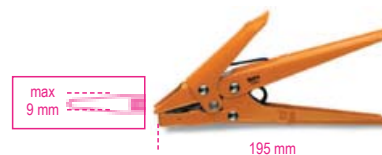

L mm	A mm	B mm	€	📦	🖨️
195	85	17	57,00	1	017434001

1750HS

compressori a leva per grasso

con sistema anticaduta H-SAFE



1 g, 550 bar Max

cc	L mm	€	📦	🖨️
500	380	48,00	1	017504500

1760BHS

multimetro digitale

con sistema anticaduta H-SAFE



PARAMETRI RILEVABILI
Tensione DC: 200 mV-2/20/200/1000V
Tensione AC: 2-20/200/700V
Corrente DC: 2/20/200 mA-20 A
Corrente AC: 2/200 mA- 20 A
Resistenza: 200Ω - 2/20/200 kΩ - 2/20 MΩ
Capacità: 2/20/200 nF - 2/200 μF
Temperatura: -20° + 1000°C/ -4 °F ~ +2000°F
Frequenza: 20kHz
Alimentazione: 1 batteria da 9V (inclusa)

1760BHS	€	📦	🖨️
	189,00	1	017604012

Beta

Beta

1772H-HS

cutter a lama retrattile di sicurezza,
fornito con 2 lame

con sistema anticaduta H-SAFE



L mm	A mm	€	1	017724029
170	18	24,50		

1778SOS-HS

coltello soccorso auto
con funzione martello frangicristallo
e tagliacinture di sicurezza
• in astuccio

con sistema anticaduta H-SAFE



L mm	A mm	L1 mm	€	1	017784080
205	25	85	39,50		

8871

cinturone di sicurezza
con fibbia metallica a doppia chiusura,
per il collegamento degli utensili H-SAFE



L cm min-max	€	1	088710070
70 100	112,00 121,00		
70-100 100-135			088710100

8872A

passante fisso

• Per cinturone 8871



8872A 50	€	1	088720050
	19,50		

8872AS

passante apribile a strappo

• Per cinturone 8871



8872AS 25	€	1	088720525
	18,00		

8873

Sacca portautensili
con chiusura autoserrante e zip

• Per cinturone 8871



8873	€	1	088730230
	95,00		

8877

laccio di collegamento ammortizzato

• MAX 2.7 kg



8877 80	L cm min+max	DxL mm	€	1	088770080
	70-110	40x80	24,00		

8877M

laccio di collegamento ammortizzato

• Con giunto anti-attorcigliamento
• MAX 2.7 kg



8877M	L cm min+max	DxL mm	€	1	088770510
	20-140	30x60	43,50		

8879

polsiera a strappo

• MAX 2.7 kg



8879	D mm	€	1	088790025
	30	28,00		

8880

laccio di collegamento non ammortizzato

• Con giunto
anti-attorcigliamento



8880	L Cm	D mm	€	1	088800030
	30	10	22,00		

8883

sacca portautensili

• In nylon 840 antiabrasione
• MAX 20 kg
• Moschettone per bloccare
la zip a fine corsa
• 6 lacci trattieni-utensile
• Tasca interna



8883	DxH cm	€	1	088830030
	30x40	229,00		





UTENSILI INOX



L'**acciaio inossidabile** è un acciaio legato con una elevata percentuale di cromo. Il cromo crea una patina superficiale di ossido che protegge il metallo e che si riforma immediatamente in caso di danneggiamento chimico o meccanico.

Sfruttando questa straordinaria caratteristica, **Beta Utensili** ha ideato la linea **Beta Inox**, una gamma di utensili che garantiscono elevata resistenza alla corrosione e spiccate caratteristiche di **igienicità e bassa ritentività batterica**. Gli utensili realizzati in acciaio inossidabile, infatti, **si sporcano meno e si puliscono meglio** di quelli realizzati con altri materiali, e possono essere **sterilizzati in autoclave a 121°C**.

Gli utensili **Beta Inox** possono essere utilizzati in **ambienti critici**, ovvero zone e aree in cui non è ammesso il minimo livello di contaminazione.

Campi di applicazione:

- Industria alimentare
- Produzione farmaceutica CLASSE C
- Laboratori biotecnologici e biomedici
- Applicazioni nucleari

Gli utensili **Beta Inox** evitano fenomeni di contaminazione ferrosa, con conseguente presenza di **ruggine impropria**. Quando si utilizzano utensili realizzati con comuni acciai al carbonio su viti, dadi o superfici in acciaio inossidabile, dagli utensili si possono disperdere particelle di ferro che generano problemi estetici (**macchie di ruggine**) che, se trascurati, innescano processi di corrosione localizzati. L'utilizzo di



INOX + NO INOX
= RUGGINE



INOX + INOX
= NO RUGGINE

utensili in acciaio inossidabile esclude completamente la diffusione di particelle inquinanti.

Campi di applicazione:

- Cantieri navali
- Edilizia
- Applicazioni offshore
- Impianti solari
- Industria automobilistica

Caratteristiche meccaniche

Gli utensili Beta sono realizzati in **acciaio AISI 420**, magnetico e con elevate caratteristiche meccaniche che permettono di costruire utensili che raggiungono prestazioni ampiamente superiori ai valori di norma e comparabili ai normali utensili Beta. L'ergonomia e il design sono gli stessi degli utensili Beta, conosciuti e apprezzati dagli utilizzatori professionali da più di 80 anni. I contenitori sono realizzati in **acciaio AISI 304**, che ha elevate caratteristiche di formabilità a freddo e una resistenza alla corrosione ancora maggiore.

Riciclabilità

L'acciaio inossidabile è **riciclabile al 100%**. Anche questa è una caratteristica importante.



Marchio per i prodotti in acciaio inossidabile
È un marchio rilasciato dal Centro Inox –
Associazione per lo studio e lo sviluppo degli
acciai inossidabili, che caratterizza i prodotti
realizzati in acciaio inossidabile.

34INOX

scalpelli piatti,
in acciaio inossidabile



L mm	A mm	Ø mm	€	🔧	📦
160	18	18	34,00	1	000340318
200	20	20	50,00	1	000340320

39INOX

cunei,
in acciaio inossidabile



L mm	A mm	S mm	€	🔧	📦
100	50	10	23,80	1	000390310
150	50	13	43,00	1	000390315
200	40	40	125,00	1	000390320

42INOX

chiavi combinate,
in acciaio inossidabile



DIN 3113 - UNI ISO 7738

Ø mm	L mm	€	🔧	📦
6x6	95	11,90	2	000420306
7x7	105	12,30	2	000420307
8x8	116	12,40	2	000420308
9x9	127	13,40	2	000420309
10x10	137	14,10	2	000420310
11x11	148	15,20	2	000420311
12x12	158	15,90	2	000420312
13x13	169	16,10	2	000420313
14x14	180	16,70	2	000420314
15x15	190	17,20	2	000420315
16x16	201	17,60	2	000420316
17x17	212	19,90	2	000420317
18x18	222	21,30	2	000420318
19x19	233	22,80	2	000420319
21x21	254	28,50	1	000420321
22x22	264	29,50	1	000420322
24x24	285	32,50	1	000420324
27x27	290	92,50	1	000420327
30x30	320	113,00	1	000420330
32x32	340	123,00	1	000420332
36x36	360	172,00	1	000420336
38x38	430	184,00	1	000420338
41x41	430	216,00	1	000420341
46x46	480	248,00	1	000420343
50x50	520	267,00	1	000420345
55x55	560	290,00	1	000420347
60x60	595	322,00	1	000420350



42INOX/S11	180,00	1	000420391
6-8-10-11-12-13-14-15-16-17-19 mm			



42INOX/SC9	157,00	1	000420387
8-10-11-12-13-14-15-17-19 mm			
42/SCV9I	8,50	1	000420103

42INOX-AS

chiavi combinate,
in acciaio inossidabile



Ø	L mm	€	🔧	📦
1/4x1/4	95	14,20	1	000420356
5/16x5/16	116	14,40	1	000420358
3/8x3/8	137	17,40	1	000420360
7/16x7/16	148	18,70	1	000420361
1/2x1/2	169	19,20	1	000420363
9/16x9/16	180	20,70	1	000420364
5/8x5/8	201	21,80	1	000420366
11/16x11/16	212	25,00	1	000420367
3/4x3/4	233	28,00	1	000420369
13/16x13/16	254	32,50	1	000420371
7/8x7/8	264	33,50	1	000420372
15/16x15/16	285	38,00	1	000420373



42INOX-AS/S9	179,50	1	000420396
1/4-5/16-3/8-7/16-1/2-9/16-5/8-11/16-3/4			



96BPINOX

chiavi maschio esagonale piegate con
estremità sferica,
in acciaio inossidabile



mm	L mm	L1 mm	Ø mm	g	€	🔧	📦
2	91	22	4		4,20	4	000961441
2,5	91	22	6		4,20	4	000961442
3	101	24	11		4,50	4	000961443
4	112	29	19		4,90	4	000961444
5	131	33	32		5,90	4	000961445
6	154	36	51		6,50	4	000961446
7	164	40	65		8,50	2	000961447
8	175	44	116		10,30	2	000961448
10	197	51	189		12,80	2	000961450



96BPINOX/B6	41,50	1	000961455
2,5-3-4-5-6-8 mm			
96BPINOX/B9	67,00	1	000961456
2-2,5-3-4-5-6-7-8-10 mm			
96BPINOX/BV	5,00	1	000961459

96BPINOX-AS

chiavi maschio esagonale piegate con
estremità sferica,
in acciaio inossidabile



mm	L mm	L1 mm	Ø mm	g	€	🔧	📦
5/64	91	22	5,5		5,40	4	000961989
3/32	91	22	5,3		5,40	4	000961990
7/64	101	24	10,5		5,80	4	000961991
1/8	101	24	10,7		5,80	4	000961992
9/64	112	29	18,7		6,30	4	000961993
5/32	112	29	18,7		6,30	4	000961994
3/16	131	33	31,5		8,50	2	000961995
7/32	154	36	50,0		8,80	2	000961996
1/4	164	40	70,0		9,30	2	000961997
5/16	175	44	115,0		11,00	2	000961998
3/8	197	51	186,5		13,70	2	000961999



96BPINOX-AS/B8	65,50	1	000962000
5/64-3/32-1/8-5/32-3/16-7/32-1/4-5/16			
96BPINOX/BV	5,00	1	000961459

96TINOX

chiavi maschio esagonale piegate
con impugnatura di manovra,
in acciaio inossidabile

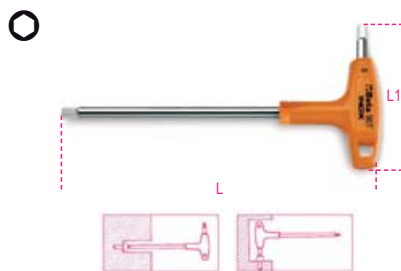

mm	L mm	L1 mm	€		
2,5	153	55	10,00	2	000961935
3	153	55	10,50	2	000961936
4	179	70	11,50	2	000961938
5	200	84	12,70	2	000961940
6	221	95	13,90	2	000961941
7	236	106	16,00	2	000961942
8	255	117	19,00	2	000961943
10	285	132	24,70	2	000961944



96TINOX/S5 2,5-3-4-5-6 mm	€ 58,50	1	000961952
96TINOX/S8 2,5-3-4-5- 6-7-8-10 mm	118,50	1	000961954

96TINOX-AS

chiavi maschio esagonale piegate
con impugnatura di manovra,
in acciaio inossidabile

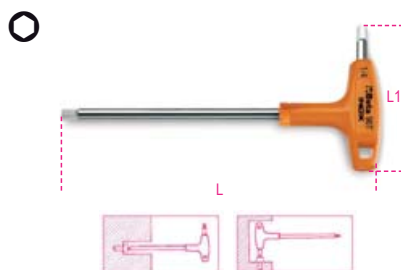

"	L mm	L1 mm	Ø mm	€		
3/32	153	55	3	11,00	2	000961861
7/64	153	55	4	11,30	2	000961862
1/8	179	70	4	12,60	2	000961863
9/64	179	70	5	12,90	2	000961864
5/32	200	84	6	13,60	2	000961865
3/16	200	84	6	14,60	2	000961866
7/32	221	103	7	17,00	2	000961867
1/4	236	106	8	17,70	2	000961868
5/16	255	117	10	21,70	2	000961869
3/8	285	132	12	23,80	2	000961870



96TINOX-AS/S7 3/32-1/8-5/32-3/16- 7/32-1/4-5/16	€ 108,00	1	000961877
---	----------	---	-----------

111INOX

chiavi regolabili a rullino,
in acciaio inossidabile



DIN 3117 - ISO 6787

L mm	L "	A max mm	A1 mm	€		
150	6	18	45	73,00	1	001110315
200	8	24	58	95,00	1	001110320
250	10	30	70	118,00	1	001110325

362INOX

giratubi modello americano,
in acciaio inossidabile



L mm	Ø max mm	€		
300	58	160,00	1	003620430

920INOX-A

chiavi a bussola a mano
bocca esagonale
in acciaio inossidabile



DIN 3124 - UNI ISO 2725

Ø mm	Ø mm	A mm	L mm	€		
8	15	10	40	26,00	2	009203008
9	16	10	40	27,50	2	009203009
10	17	10	40	29,00	2	009203010
11	18	11	40	30,50	2	009203011
12	19	11	40	32,50	2	009203012
13	20	11	40	34,50	2	009203013
14	21	11	40	36,00	2	009203014
15	23	11	40	38,00	2	009203015
16	24	11	40	39,50	2	009203016
17	25	11	40	40,50	2	009203017
18	26	13	42	42,50	2	009203018
19	28	13	42	44,50	2	009203019
20	29	13	42	47,00	1	009203020
21	30	13	43	47,50	1	009203021
22	31	15	43	48,00	1	009203022
24	34	15	43	56,00	1	009203024
27	38	18	46	68,50	1	009203027
30	42	20	46	81,00	1	009203030
32	44	20	46	91,50	1	009203032

920/55INOX

cricchetto reversibile
con attacco quadro maschio 1/2"
meccanismo a 72 denti
in acciaio inossidabile



L mm	Ø mm	A mm	€		
264	40	43	194,00	1	009203882

920/R55INOX

12"
72



920/R55INOX	€ 69,00	1	009203879
-------------	---------	---	-----------

1048INOX

pinza regolabile cerniera chiusa
in acciaio inossidabile

• modello a sette posizioni

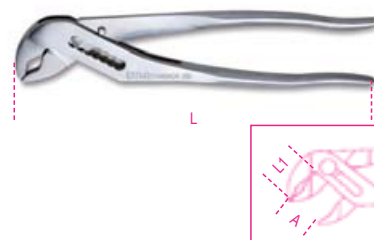

L mm	A max mm	L1 mm	€		
250	33	33	124,00	1	010480325

1082INOX

tronchesi a taglienti diagonali,
in acciaio inossidabile



L mm	L1 mm	mm	€		
150	20,0	1,6	89,00	1	010820350

1150INOX

Pinza universale a grande effetto
in acciaio inossidabile

perno decentrato
cassetta aperta



L mm	L1 mm	€		
180	39	88,00	1	011500518

1153INOX

pinza regolabile a due posizioni,
in acciaio inossidabile



L mm	L1 mm	€		
150	26	86,00	1	011530315

1290INOX

giravite per viti a testa con intaglio
in acciaio inossidabile



ISO 2380

SxAxL mm	L1 mm	Ø mm	€	🔧	📦
0,4x2,5x50	146	2.5	7,40	4	012900403
0,5x3x75	171	3.0	7,50	4	012900409
0,8x4x100	196	4.0	7,90	4	012900430
1,0x5,5x150	259	5.0	9,90	4	012900442
1,2x6,5x150	270	6.0	11,50	4	012900451

1292INOX

giravite per viti con impronta a croce Phillips®,
in acciaio inossidabile



ISO 8764

PHxDxL mm	L1 mm	€	🔧	📦
0x3x60	156	6,90	4	012920403
1x4,5x80	189	8,20	4	012920409
2x6x100	220	9,90	4	012920418

1293INOX/D8

serie giravite
in acciaio inossidabile



🔧📦
1293INOX/D8 € 69,00 1 012930408

1290INOX	0,4x2,5x50-0,5x3x75 0,8x4x100-1,0x5,5x150- 1,2x6,5x150 mm
1292INOX	PH0x60-PH1x80 PH2x100 mm

1370INOX

martello tipo tedesco
per meccanici
in acciaio inossidabile



g	A mm	L mm	L1 mm	€	🔧	📦
500	25	240	101	77,00	1	013700375

1377INOX

martelli con testa tonda
e penna sferica
per calderai e lattonieri
in acciaio inossidabile



g	L mm	L1 mm	€	🔧	📦
230	220	82	46,00	1	013770623
340	220	90	65,00	1	013770634

1730INOX

spatola universale,
in acciaio inossidabile



A mm	L mm	€	🔧	📦
50	200	39,50	1	017300450

G20TSS

cestello estendibile a cinque scomparti
in acciaio inossidabile AISI 304



🔧📦
G20TSS € 241,00 1 021203001

📏: 450x200x210 mm - 🏠 4kg

Beta

Beta

C04TSS-7

cassettiera mobile con sette cassetti
in acciaio inossidabile, con ruote antitraccia

Caratteristiche principali:

- Sette cassetti da 570 x 410 mm montati su guide telescopiche a sfera;
- 6 cassetti altezza 83 mm;
- 1 cassetto altezza 170 mm;
- quattro ruote antitraccia con nucleo in acciaio inossidabile Ø 125mm
- 2 fisse e 2 girevoli (due con freno);
- Serratura frontale centralizzata;
- **Struttura interamente in acciaio inossidabile AISI 304**
- **Ruote, supporti, sfere, interno dei cassetti e relative guide in acciaio inossidabile**
- Maniglia cassetti in alluminio

63 kg

Beta
NOX
STAINLESS STEEL

700
kg

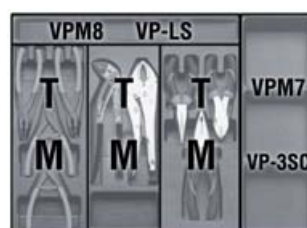

h	max
83 mm	25 kg
170 mm	30 kg

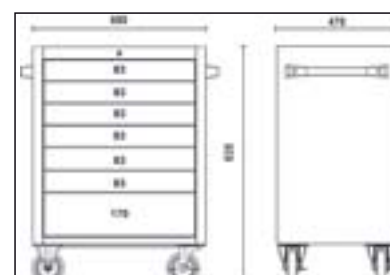
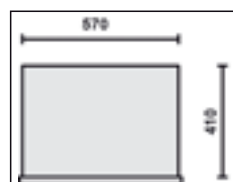

C04TSS/7

€ 2.160,00 1 024003077



UTENSILI ANTISCINTILLA

RAME-BERILLIO Cu-Be

Gli utensili Antiscintilla **Beta** sono specifici per operare in assoluta sicurezza in ambienti a potenziale rischio di esplosioni, con presenza di liquidi o gas infiammabili, o per applicazioni che richiedono l'utilizzo di utensili amagnetici e resistenti alla corrosione.



Gli utensili antiscintilla Beta sono certificati dall'Istituto per la ricerca e il collaudo BAM, secondo la Direttiva Europea 99/92/EC.

CLASSIFICAZIONE DELLE ZONE A RISCHIO DI ESPLOSIONE

ATEX	MEDIO BASSA	MOLTO BASSA
	GAS	ZONA 1 Area in cui durante le normali attività è probabile la formazione di un'atmosfera esplosiva consistente in una miscela di aria e di sostanze infiammabili sotto forma di gas, vapore o nebbia.
POLVERI	ZONA 21 Area in cui occasionalmente durante le normali attività è probabile la formazione di un'atmosfera esplosiva sotto forma di nube di polvere combustibile nell'aria.	ZONA 22 Area in cui durante le normali attività non è probabile la formazione di un'atmosfera esplosiva sotto forma di nube di polvere combustibile nell'aria e, qualora si verifichi, sia unicamente di breve durata.



ATTENZIONE:
rischio di esplosione
in presenza di
ACETILENE

Le caratteristiche meccaniche degli utensili Antiscintilla **Beta** sono diverse da quelle degli utensili normali in acciaio, devono essere usati con estrema cautela, evitando sovraccarichi.

30BA

punzoni antiscintilla



Ø mm	L mm	S mm	€	🔧	📄
5	150	15	51,00	1	000300806
8	150	17	63,00	1	000300808
10	150	19	78,00	1	000300810

31BA

cacciaspina antiscintilla



Ø mm	L mm	€	🔧	📄
3	110	22,50	1	000310853
4	110	48,00	1	000310854
6	115	73,00	1	000310856
8	120	83,00	1	000310858

31BA/C

punzoni antiscintilla conici



Ø mm	Ø1 mm	L mm	€	🔧	📄
★6	12	150	30,00	1	000310876
★7	13	150	35,00	1	000310877
★12	18	175	75,00	1	000310882
★13	29	255	235,00	1	000310883

32BA

bulino antiscintilla



● mm	L mm	€	🔧	📄
14	150	71,00	1	000320811

34BA

scalpelli piatti antiscintilla



L mm	A mm	€	🔧	📄
200	22	96,00	1	000340801
250	24	160,00	1	000340803
300	25	215,00	1	000340802

39BA

cunei antiscintilla



L mm	A mm	€	🔧	📄
150	40	41,50	1	000390801
230	40	140,00	1	000390802
250	40	220,00	1	000390803

42BA

chiavi combinate antiscintilla



● mm	L mm	€	🔧	📄
6x6	105	45,00	1	000420806
7x7	105	50,00	1	000420807
8x8	120	56,00	1	000420808
9x9	120	64,00	1	000420809
10x10	135	69,50	1	000420810
11x11	135	73,00	1	000420811
12x12	150	80,00	1	000420812
13x13	150	83,00	1	000420813
14x14	175	87,00	1	000420814
15x15	175	91,00	1	000420815
16x16	195	95,00	1	000420816
17x17	200	99,50	1	000420817
18x18	215	111,50	1	000420818
19x19	220	113,50	1	000420819
20x20	230	118,50	1	000420820
21x21	240	125,50	1	000420821
22x22	250	134,00	1	000420822
24x24	268	155,00	1	000420824
26x26	290	188,00	1	000420826
27x27	290	208,00	1	000420827
28x28	290	245,00	1	000420828
30x30	313	250,00	1	000420830
32x32	333	275,00	1	000420832
34x34	360	300,00	1	000420834
35X35	360	340,00	1	000420835
36x36	355	355,00	1	000420836
38x38	430	375,00	1	000420838
41x41	430	440,00	1	000420841
46x46	480	515,00	1	000420846
50x50	520	545,00	1	000420850
55x55	560	600,00	1	000420855
60x60	580	640,00	1	000420860
★65x65	595	730,00	1	000420865
★70x70	630	820,00	1	000420870

42BA-AS

chiavi combinate antiscintilla



● mm	L mm	€	🔧	📄
9/32x9/32	120	48,00	1	000420946
5/16x5/16	120	48,00	1	000420947
11/32x11/32	135	61,00	1	000420948
3/8x3/8	128	64,00	1	000420950
7/16x7/16	135	73,00	1	000420951
15/32x15/32	140	80,50	1	000420949
1/2x1/2	140	84,00	1	000420953
9/16x9/16	163	90,00	1	000420954

● "	L mm	€	🔧	📄
★19/32x19/32	195	109,00	1	000420955
5/8x5/8	177	110,00	1	000420956
11/16x11/16	195	117,00	1	000420957
3/4x3/4	215	120,00	1	000420959
13/16x13/16	230	140,00	1	000420961
7/8x7/8	235	146,00	1	000420962
15/16x15/16	256	162,00	1	000420964
★31/32x31/32	265	178,00	1	000420963
1x1	266	175,00	1	000420965
1.1/16x1.1/16	283	197,00	1	000420967
1.1/8x1.1/8	297	259,00	1	000420969
1.3/16x1.3/16	308	280,00	1	000420970
1.1/4x1.1/4	324	330,00	1	000420973
★1.7/16x1.7/16	360	400,00	1	000420976

55BA

chiavi a forchetta doppie antiscintilla



● mm	L mm	€	🔧	📄
6x7	90	31,00	1	000550801
8x9	100	33,00	1	000550802
8x10	100	34,00	1	000550795
9x11	110	36,50	1	000550797
10x11	120	39,00	1	000550803
12x13	130	48,50	1	000550804
★12x14	130	59,50	1	000550846
13x14	133	59,00	1	000550799
14x15	145	59,50	1	000550805
14x17	150	63,00	1	000550806
16x17	165	63,50	1	000550807
17x19	170	84,00	1	000550847
18x19	170	86,00	1	000550809
★19x22	185	97,50	1	000550810
20x22	185	98,50	1	000550811
21x23	210	107,00	1	000550813
22x24	210	128,00	1	000550815
24x26	230	150,00	1	000550817
24x27	230	160,00	1	000550818
25x28	230	173,00	1	000550819
27x29	246	203,00	1	000550820
30x32	265	237,00	1	000550822
36x38	320	300,00	1	000550826
36x41	335	330,00	1	000550828
41x46	355	410,00	1	000550829
★46x50	370	470,00	1	000550830
★50x55	385	500,00	1	000550831
★55x60	415	620,00	1	000550832

55BA-AS

chiavi a forchetta doppie antiscintilla



● "	L mm	€	🔧	📄
3/8x7/16	110	40,00	1	000550853
1/2x9/16	130	48,00	1	000550854
5/8x11/16	160	71,00	1	000550857
3/4x13/16	180	87,00	1	000550859
7/8x15/16	210	122,00	1	000550865
1x1.1/16	230	165,00	1	000550868
1.1/8x1.3/16	245	215,00	1	000550870
1.1/4x1.5/16	255	255,00	1	000550872

58BA

chiavi a forchetta semplici a percussione, antiscintilla



mm	L mm	€		
17	125	82,00	1	000580817
19	125	85,50	1	000580819
22	135	86,00	1	000580822
24	150	96,50	1	000580824
27	165	118,00	1	000580827
30	180	148,00	1	000580830
32	190	173,00	1	000580832
*34	200	198,00	1	000580834
36	210	205,00	1	000580836
38	220	225,00	1	000580838
41	230	255,00	1	000580841
46	240	305,00	1	000580846
50	255	345,00	1	000580850
*55	305	430,00	1	000580855
*60	315	500,00	1	000580860
*65	335	580,00	1	000580865
*70	370	700,00	1	000580870
*75	375	810,00	1	000580875
*80	400	970,00	1	000580880
*85	400	1.140,00	1	000580885
*90	445	1.360,00	1	000580890
*95	445	1.565,00	1	000580895
*100	485	1.815,00	1	000580900
*110	513	2.245,00	1	000580901

58BA-AS

chiavi a forchetta semplici a percussione, antiscintilla



mm	L mm	A mm	S mm	€		
*11/16	125	40,5	11,0	90,00	1	000580904
*3/4	125	40,5	11,0	92,00	1	000580905
*7/8	135	46,2	12,0	94,50	1	000580906
*15/16	150	50,3	12,0	108,00	1	000580907
*31/32	150	50,3	12,0	121,00	1	000580954
*1	175	56,9	15,0	125,00	1	000580908
*1.1/8	190	64,0	15,5	161,00	1	000580909
*1.1/4	190	64,0	15,5	189,00	1	000580910
*1.7/16	210	75,0	18,5	220,00	1	000580912
*1.1/2	220	82,0	18,5	260,00	1	000580913
*1.5/8	230	86,8	18,5	280,00	1	000580914
*1.3/4	250	98,0	20,	355,00	1	000580970

78BA

chiavi poligonali a percussione, antiscintilla



mm	L mm	€		
17	145	86,00	1	000780817
19	145	94,00	1	000780819
22	165	96,00	1	000780822
24	140	117,00	1	000780824
27	155	134,00	1	000780827
30	165	155,00	1	000780830
32	180	168,00	1	000780832
34	192	185,00	1	000780834
36	208	205,00	1	000780836
38	215	240,00	1	000780838
41	225	285,00	1	000780841
46	245	320,00	1	000780846
50	250	370,00	1	000780850
55	265	430,00	1	000780855
60	275	465,00	1	000780860
65	295	500,00	1	000780865
70	310	565,00	1	000780870

mm	L mm	€		
75	325	635,00	1	000780875
80	340	680,00	1	000780880
*85	355	865,00	1	000780885
*90	380	1.020,00	1	000780890
*95	390	1.180,00	1	000780895
*100	410	1.350,00	1	000780900
*105	420	1.490,00	1	000780903
*110	445	1.700,00	1	000780901
*120	480	2.010,00	1	000780902

78BA-AS

chiavi poligonali a percussione, antiscintilla



mm	L mm	€		
11/16	145	85,00	1	000780908
3/4	145	88,00	1	000780909
7/8	155	98,50	1	000780935
15/16	165	109,00	1	000780936
*31/32	165	127,00	1	000780937
1	175	127,00	1	000780938
*1.1/16	175	151,00	1	000780939
1.1/8	180	152,00	1	000780940
1.3/16	185	158,00	1	000780941
1.1/4	177	172,00	1	000780910
*1.5/16	200	175,00	1	000780954
*1.3/8	205	183,00	1	000780911
1.7/16	208	228,00	1	000780912
*1.1/2	215	238,00	1	000780913
*1.9/16	225	295,00	1	000780947
*1.11/16	225	310,00	1	000780962
1.5/8	225	290,00	1	000780914
*1.3/4	235	320,00	1	000780963
1.13/16	243	330,00	1	000780916
1.7/8	235	375,00	1	000780915
2	254	390,00	1	000780918
2.3/16	264	455,00	1	000780920
2.3/8	275	495,00	1	000780922
*2.9/16	286	515,00	1	000780924
*2.15/16	311	625,00	1	000780926
*3.1/8	325	725,00	1	000780928
*3.1/2	355	915,00	1	000780930

89BA

chiavi poligonali semplici, antiscintilla



mm	L mm	€		
10	200	97,00	1	000890810
11	210	101,00	1	000890811
12	220	104,00	1	000890812
13	230	107,00	1	000890813
14	240	109,00	1	000890814
16	260	117,00	1	000890816
17	270	121,00	1	000890817
18	280	130,00	1	000890818
19	300	135,00	1	000890819
20	310	168,00	1	000890820
22	330	168,00	1	000890822
24	350	184,00	1	000890824
27	370	227,00	1	000890827
30	400	255,00	1	000890830
32	420	268,00	1	000890832

90BA

chiavi poligonali doppie antiscintilla



mm	L mm	€		
6x7	122	31,50	1	000900801
8x9	128	40,00	1	000900802
10x11	155	46,00	1	000900803
12x13	175	53,50	1	000900806
12x14	180	57,00	1	000900807
14x15	200	63,50	1	000900808
14x17	220	65,00	1	000900809
16x17	230	76,00	1	000900811
16x18	235	76,00	1	000900812
17x19	250	79,00	1	000900814
18x19	265	87,00	1	000900815
19x22	280	91,00	1	000900817
20x22	295	103,00	1	000900818
21x23	298	110,00	1	000900820
22x24	315	132,00	1	000900821
24x26	333	170,00	1	000900822
24x27	340	170,00	1	000900823
30x32	395	250,00	1	000900824
34x36	410	355,00	1	000900826
*36x41	450	480,00	1	000900828
*41x46	470	590,00	1	000900829
*46x50	490	655,00	1	000900830

91BA

chiavi poligonali curve antiscintilla



mm	Ø mm	€		
24	38	205,00	1	000910824
27	42	245,00	1	000910827
30	48	280,00	1	000910830
32	49	312,00	1	000910832
36	54	340,00	1	000910836
41	62	380,00	1	000910841
*46	69	505,00	1	000910846
*50	75	540,00	1	000910850
*55	82	625,00	1	000910855

92BA

leve di manovra per art. 91BA, antiscintilla



	L mm	91BA mm	Ø mm	€		
92BA/1	460	24+30	25	242,00	1	000920810
92BA/2	610	32+41	28	312,00	1	000920820
*92BA/3	760	46+55	32	420,00	1	000920830

93BA

chiave a cricchetto per ponteggi antiscintilla



mm	L mm	€		
21x22	345	505,00	1	000930821

95BA

chiavi poligonali doppie diritte, antiscintilla



Ø mm	L mm	€	🔧	📄
7x9	115	31,00	1	000950801
8x10	115	34,00	1	000950802
10x11	140	38,00	1	000950804
10x12	140	45,00	1	000950805
12x14	145	51,00	1	000950806
14x17	165	61,00	1	000950807
*16x18	170	79,50	1	000950809
*17x19	185	69,50	1	000950808
*18x19	185	87,00	1	000950810
*19x22	200	108,00	1	000950812
*21x23	230	119,00	1	000950815
*24x27	255	152,00	1	000950817
*30x32	295	228,00	1	000950820

96BA

chiavi maschio esagonale piegate antiscintilla

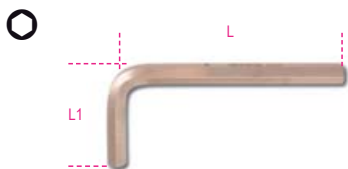

mm	L mm	L1 mm	€	🔧	📄
1,5	50	17	63,00	1	000960760
2	50	16	64,00	1	000960762
2,5	56	20	69,00	1	000960761
3	63	21	70,50	1	000960763
4	69	25	74,00	1	000960764
5	78	29	76,00	1	000960765
6	88	33	78,00	1	000960766
7	93	34	82,00	1	000960767
8	97	36	87,00	1	000960768
9	104	37	90,50	1	000960769
10	110	39	94,00	1	000960770
12	122	44	114,00	1	000960772

96BA/BP

chiavi maschio esagonale piegate con estremità sferica, antiscintilla

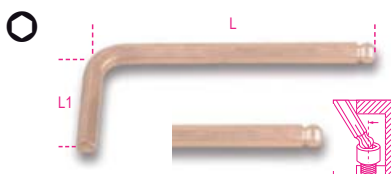

Ø mm	L mm	L1 mm	€	🔧	📄
1,5	50	16	64,50	1	000961800
2	50	16	65,00	1	000961801
2,5	63	20	73,50	1	000961802
3	60	20	74,00	1	000961803
3,5	70	25	76,50	1	000961799
4	66	25	77,00	1	000961804
5	75	28	79,00	1	000961805
6	84	32	81,50	1	000961806
8	92	36	88,50	1	000961808
10	102	40	96,00	1	000961810
12	113	45	118,00	1	000961812

96BAF-AS

chiavi maschio esagonali piegate, antiscintilla



Ø mm	L mm	L1 mm	€	🔧	📄
*1/16	59	25	51,00	1	000962831
*5/64	59	25	53,00	1	000962832
*3/32	59	25	55,00	1	000962833
*7/64	59	25	57,50	1	000962834
*1/8	59	25	60,00	1	000962835
*9/64	64	29	64,00	1	000962836
*5/32	65	30	66,50	1	000962837
*3/16	79	31	70,50	1	000962838
*7/32	85	37	73,00	1	000962839
*1/4	85	37	76,00	1	000962840
*5/16	92	44	82,50	1	000962842
*3/8	110	45	89,00	1	000962844
*7/16	119	48	96,00	1	000962845
*1/2	140	55	117,00	1	000962846

99BA

chiavi a settore articolate con nasello quadro antiscintilla per ghiera



Ø mm	A mm	€	🔧	📄
32-75	4,0	166,00	1	000990803
50-120	4,5	260,00	1	000990805
115-170	4,5	420,00	1	000990811

110BA

chiavi regolabili a rullino, antiscintilla



L mm	A max	€	🔧	📄
100	13	123,00	1	001100810
150	18	141,00	1	001100815
200	24	166,00	1	001100820
250	30	200,00	1	001100825
300	36	281,00	1	001100830
375	46	378,00	1	001100837
*450	55	530,00	1	001100845
*600	65	885,00	1	001100860

330BA

tagliatubi per tubi gas, antiscintilla

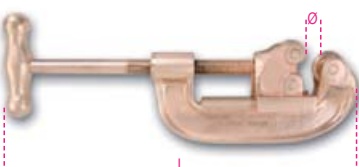

330BA/2	Ø max 50 mm	L 375	€	🔧	📄
			645,00	1	003300802

330BA/2R

coltello e spina di ricambio per 330BA per tubi gas, antiscintilla



330BA /2-R	€	🔧	📄
	65,00	1	003300822

363BA

giratubi modello americano, antiscintilla



L mm	Ø max 1" gas	Ø max mm	€	🔧	📄
150	1" gas	20	209,00	1	003630815
200	1" gas	30	210,00	1	003630820
250	1 1/2 gas	49	245,00	1	003630825
300	2" gas	60	310,00	1	003630830
350	2" gas	60	385,00	1	003630835
450	2 1/2 gas	76	585,00	1	003630845
600	3" gas	90	815,00	1	003630860

378BA

giratubi modello svedese, antiscintilla



L mm	Ø max 1" 1/2 gas	€	🔧	📄
430	1" 1/2 gas	637,00	1	003780800
530	2" gas	785,00	1	003780801

386BA

giratubi reversibili a catena modello pesante antiscintilla

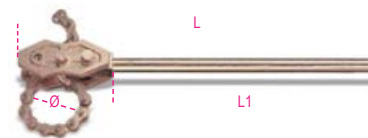

L mm	Ø max mm	L1 mm	€	🔧	📄
600	100	470	960,00	1	003860806
900	200	750	1.600,00	1	003860809

911BA

chiavi a bussola poligonali, antiscintilla

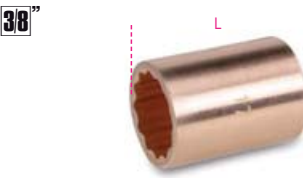

Ø mm	L mm	€	🔧	📄
6	28	42,50	1	009110806
7	28	46,00	1	009110807
8	28	48,50	1	009110808
9	28	52,00	1	009110809

mm	L mm	€	1	009110810
10	32	71,00	1	009110810
11	32	74,50	1	009110811
12	32	78,50	1	009110812
13	32	82,00	1	009110813
14	32	87,50	1	009110814
15	32	88,00	1	009110815
16	32	92,00	1	009110816
17	32	96,00	1	009110817
18	32	97,00	1	009110818
19	32	101,00	1	009110819

911BA/16

raccordo con attacco quadro femmina 3/8" e maschio 1/2" antiscintilla

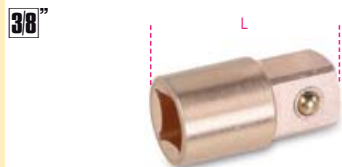

L mm	□	■	€	1	009110836
34	3/8	1/2	89,00	1	009110836

911BA/20

prolunga con attacco quadro maschio e femmina 3/8", antiscintilla



L mm	€	1	009110840
75	72,50	1	009110840

911BA/55

cricchetto semplice con quadro scorrevole 3/8", antiscintilla

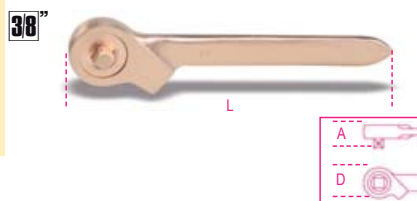

L mm	D mm	A mm	€	1	009110882
200	45	16,5	154,00	1	009110882

921BA

chiavi a bussola poligonali, antiscintilla



mm	Ø mm	L mm	€	1	009210808
8	24,0	40	63,50	1	009210808
9	24,0	40	67,50	1	009210809
10	16,5	40	76,50	1	009210810
11	17,5	40	79,50	1	009210811
12	18,5	40	85,00	1	009210812
13	19,5	40	89,00	1	009210813
14	20,0	40	91,00	1	009210814
15	21,5	40	95,00	1	009210815

mm	Ø mm	L mm	€	1	009210816
16	24,0	40	98,00	1	009210816
17	25,0	40	102,00	1	009210817
18	25,0	40	105,00	1	009210818
19	28,0	42	109,00	1	009210819
20	29,0	42	114,00	1	009210820
21	30,0	43	116,00	1	009210821
22	30,5	43	121,00	1	009210822
24	34,0	43	142,00	1	009210824
25	36,0	43	154,00	1	009210825
26	37,5	43	164,00	1	009210826
27	37,5	45	172,00	1	009210827
28	38,9	46	180,00	1	009210828
30	41,5	46	203,00	1	009210830
32	43,5	46	223,00	1	009210832

921BA-AS

chiavi a bussola poligonali, antiscintilla

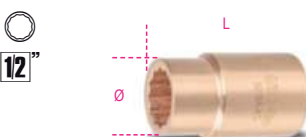

"	Ø mm	L mm	€	1	009210958
5/16	24,0	40	68,00	1	009210958
3/8	24,0	40	73,50	1	009210960
7/16	24,0	40	80,00	1	009210961
1/2	24,0	40	86,00	1	009210963
9/16	24,0	40	89,00	1	009210964
5/8	25,0	40	102,00	1	009210966
11/16	25,5	40	110,00	1	009210967
3/4	28,0	42	121,00	1	009210969
13/16	30,0	43	128,00	1	009210971
7/8	31,5	43	139,00	1	009210972
15/16	34,0	43	147,00	1	009210974
1	36,0	43	164,00	1	009210975
1.1/16	38,0	46	177,00	1	009210977
1.1/4	42,0	46	235,00	1	009210982
1.7/16	50,5	50	290,00	1	009210986

921BA/15

raccordo con attacco quadro femmina 1/2" e maschio 3/8" antiscintilla

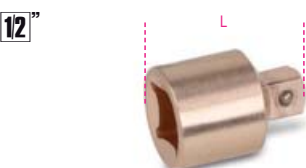

L mm	□	■	€	1	009210839
34	1/2	3/8	81,00	1	009210839

921BA/21 - 921BA/22

prolunghe con attacchi quadri maschio e femmina 1/2", antiscintilla



	L mm	Ø mm	€	1	009210842
921BA/21	125	30	108,00	1	009210842
921BA/22	250	31	151,00	1	009210844

921BA/25

snodo con attacchi quadri maschio e femmina 1/2", antiscintilla



L mm	Ø mm	□	■	€	1	009210845
80	25	1/2	1/2	110,00	1	009210845

921BA/42

quadro maschio 1/2" con spina scorrevole, antiscintilla



L mm	€	1	009210846
250	178,00	1	009210846

921BA/50

cricchetto semplice con quadro scorrevole 1/2", antiscintilla



L mm	D mm	A mm	€	1	009210850
250	45	16,5	205,00	1	009210850

921BA/R50

set di ricambio antiscintilla



□	€	1	009210851
1/2"	61,00	1	009210851

926BA

chiavi a bussola poligonali, antiscintilla

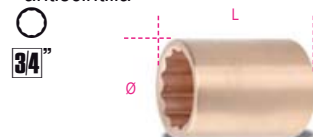

mm	Ø mm	L mm	€	1	009260822
22	40	55	134,00	1	009260822
24	40	55	150,00	1	009260824
26	40	55	170,00	1	009260826
27	40	55	180,00	1	009260827
28	41	55	210,00	1	009260828
30	43	60	215,00	1	009260830
32	45	60	240,00	1	009260832
34	48	60	256,00	1	009260834
36	50	60	276,00	1	009260836
38	53	60	295,00	1	009260838
41	57	65	325,00	1	009260841
46	63	65	385,00	1	009260846
50	68	70	422,00	1	009260850

926BA/22

prolunghe con attacchi quadri maschio e femmina 3/4", antiscintilla



926BA/22	L mm	Ø mm	€	1	009260872
	200	38	215,00		

926BA/42

quadro maschio 3/4" con spina scorrevole, antiscintilla

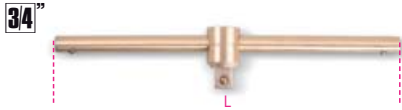

926BA/42	L mm	€	1	009260876
	400	310,00		

926BA/50

cricchetto semplice con quadro scorrevole 3/4", antiscintilla



926BA/50	L mm	D mm	A mm	€	1	009260880
	300	61	22	320,00		

926BA/R50

set di ricambio antiscintilla



926BA/R50	3/4"	€	1	009260881
		102,00		

937BA

chiavi a pipa esagonali, antiscintilla



937BA	L mm	A mm	€	1	009370813
	13	240	79,50		
	17	260	115,00		
	19	270	120,00		
	22	278	157,00		
	24	286	168,00		
	27	294	179,00		
	30	302	197,00		
	32	310	215,00		
	*36	330	253,00		
	*41	350	306,00		

951BA

chiavi a T maschio esagonale, antiscintilla



951BA	mm	L mm	L1 mm	€	1	009510904
	4	100	90	134,00		
	5	100	90	140,00		
	6	100	90	148,00		

961BA

leve scrostatore, antiscintilla



961BA	L mm	A mm	€	1	009610802
	250	39	118,00		
	350	55	178,00		

963BA

leve con estremità a punta e piatta curva, antiscintilla



963BA	L mm	A mm	€	1	009630801
	500	24	329,00		
	*800	24	517,00		
	*1000	30	1.100,00		

964BA

aprifusti antiscintilla



964BA	L mm	€	1	009640801
	385	310,00		

964BA/L

cesoia universale per fusti, antiscintilla

Per l'apertura dei fusti metallici con bordo

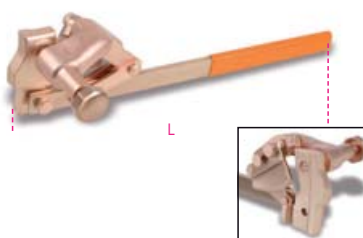

964BA/L	L mm	€	1	009640821
	*964BA/L 510	1.570,00		

965BA

chiavi di manovra semplici antiscintilla, per valvole di sicurezza



965BA	A mm	A1 mm	L mm	€	1	009650830
	30	44	200	137,00		
	32	50	300	190,00		
	35	47	250	155,00		
	40	50	300	179,00		
	45	58	350	230,00		
	48	62	375	240,00		
	50	67	400	263,00		
	55	73	450	315,00		
	60	79	500	340,00		
	*65	82	550	380,00		
	*70	85	600	420,00		

966BA

chiave di manovra antiscintilla, per valvole di sicurezza

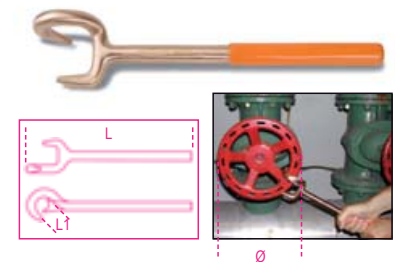

966BA	L mm	L1 mm	Ø min+max mm	€	1	009660801
	350	40	50÷150	299,00		

966BA/V

chiavi di manovra antiscintilla, per valvole di sicurezza

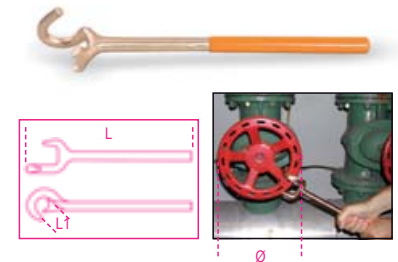

966BA/V	L mm	L1 mm	Ø min+max mm	€	1	009660812
	370	36	125÷250	299,00		
	430	48	250÷400	430,00		

1032BA

pinze a becchi diritti antiscintilla per anelli elastici di sicurezza, per fusti ricoperti in PVC



1032BA	L mm	Ø mm	€	1	010320820
	200	40÷100	195,00		

1036BA

pinze a becchi diritti antiscintilla per anelli elastici di sicurezza, per alberi manici ricoperti in PVC



L mm	mm	€	Icon	Icon
200	40÷100	195,00	1	010360820

1046BA

pinze regolabili cerniera a cremagliera, antiscintilla



L mm	A max mm	€	Icon	Icon
250	32	255,00	1	010460801
★300	52	335,00	1	010460803

1052BA

pinze regolabili autobloccanti ganasce concave, antiscintilla

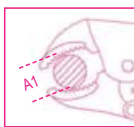

L mm	A1 max mm	€	Icon	Icon
225	40,0	250,00	1	010520824

1082BA

tronchese a taglienti diagonali, antiscintilla

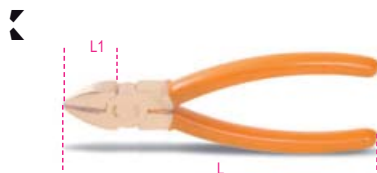

L mm	L1 mm	€	Icon	Icon
160	22	182,00	1	010820801

1100BA

troncabulloni, antiscintilla



L mm	€	Icon	Icon
600	1.300,00	1	011000860

1137BA

pinza da fochino, antiscintilla



L mm	L1 mm	€	Icon	Icon
185	30	338,00	1	011370801

1137BA/RC

lama di ricambio per 1137BA



1137BA/RC	€	Icon	Icon
	65,00	1	011370851

1150BA

pinza universale, antiscintilla

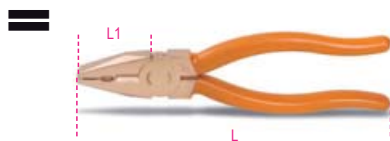

L mm	L1 mm	€	Icon	Icon
200	40	214,00	1	011500820

1162BA

pinza a becchi piatti lunghissimi dritti zigrinati, antiscintilla



L mm	L1 mm	€	Icon	Icon
150	54	168,00	1	011620815

1166BA

pinza a becchi mezzotondi lunghissimi dritti zigrinati, antiscintilla

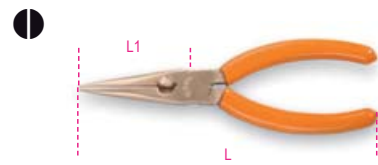

L mm	L1 mm	€	Icon	Icon
150	54	168,00	1	011660815

1270BA

giravite per viti a testa con intaglio, antiscintilla



AxL mm	L1 mm	€	Icon	Icon
3x75	178	31,00	1	012700803
4x100	209	38,00	1	012700804
5x150	250	50,00	1	012700805
6x150	270	53,50	1	012700806
10x250	382	81,00	1	012700810
8x200	312	60,50	1	012700808

1272BA

giravite per viti con impronta a croce Phillips®, antiscintilla



PHxDxL mm	L1 mm	€	Icon	Icon
1x5x100	209	42,00	1	012720801
2x6x150	270	54,00	1	012720802
3x8x200	332	64,50	1	012720803

1277BA

giravite per viti con impronta Torx®, antiscintilla



Ø	L mm	L1 mm	Ø mm	€	Icon	Icon
T10	75	184	5	40,00	1	012770810
T15	75	184	5	43,50	1	012770815
T20	100	209	6	59,00	1	012770820
T25	125	209	6	62,00	1	012770825
T30	150	270	6	68,00	1	012770830
T40	200	332	8	90,00	1	012770840

1370BA

martelli tipo tedesco antiscintilla, manico in legno



g	A mm	L mm	L1 mm	€		
500	30	310	108	112,50	1	013700805
1000	35	340	137	198,00	1	013700810

1370BA/MR

manici di ricambio per 1370BA

g	€		
1370BA/MR 500	19,00	1	013700865
1370BA/MR 1000	23,50	1	013700870

1370BA/PL

martelli tipo tedesco antiscintilla, manico in fibra



g	A mm	L mm	L1 mm	€		
500	30	310	108	112,50	1	013700815
1000	35	340	137	198,00	1	013700820

1375BA/PL

martello con penna sferica a granchio antiscintilla, manico in fibra



g	L mm	L1 mm	Ø mm	€		
680	321	125	30	145,00	1	013750800

1377BA

martello con testa tonda e penna sferica per calderai e lattonieri, antiscintilla



g	L1 mm	L mm	€		
340	90	280	72,50	1	013770834

1377BA/PL

martello con testa tonda e penna sferica per calderai e lattonieri, manico in fibra, antiscintilla



g	L1 mm	L mm	€		
340	90	280	72,50	1	013770884

1379BA

martello scrostatore antiscintilla, manico in legno



g	L1 mm	L mm	€		
500	142	315	140,00	1	013790850

1380BA

mazzette antiscintilla, manico in legno



g	L1 mm	L mm	€		
1000	100	400	242,00	1	013800810
1500	118	400	295,00	1	013800815
2000	126	400	390,00	1	013800820

1380BA/MR

manici di ricambio per 1380BA

g	€		
1380BA/MR 1000	24,50	1	013800860
1380BA/MR 1500	24,50	1	013800865
1380BA/MR 2000	24,50	1	013800870

1380BA/PL

mazzette antiscintilla, manico in fibra



g	L1 mm	L mm	€		
500	80	310	121,00	1	013800955
1000	94	350	225,00	1	013800960
1500	115	400	325,00	1	013800965
2000	125,5	400	425,00	1	013800970

1381BA

mazze antiscintilla, manico in legno



g	L1 mm	L mm	€		
5000	179	900	905,00	1	013810850
*8000	190	900	1.455,00	1	013810858

1381BA/MR

manico di ricambio per 1381BA

g	€		
1381BA/MR 5000	38,00	1	013810870
*1381BA/MR 8000	44,00	1	013810878

1381BA/PL

mazze antiscintilla, manico in fibra



g	L1 mm	L mm	€		
5000	172	900	830,00	1	013810885
8000	204	900	1.490,00	1	013810888

1390BA

mazzuola con battenti in nylon, antiscintilla



Ø mm	L mm	L1 mm	€		
*52	370	130	195,00	1	013900805



1390BA/R

battenti di ricambio in Nylon per 1390BA



D mm	€	Icon	Icon
52	39,50	4	013900885

1602BA

pinza per capicorda preisolati modello leggero, antiscintilla



mm ²	L mm	€	Icon	Icon
0.75÷6	200	239,00	1	016020801

1701BA

scalpelli esagonale, antiscintilla



L mm	A mm	S mm	€	Icon	Icon
150	12	10	44,50	1	017010810
200	16	14	71,00	1	017010814
250	18	14	87,00	1	017010815
350	19	17	228,00	1	017010817

1703BA/A

ascia antiscintilla



L mm	L1 mm	A mm	€	Icon	Icon
340	145	82	198,00	1	017030082

1703BA/P

piccone antiscintilla



A mm	L mm	L1 mm	€	Icon	Icon
56	1050	410	518,00	1	017030150

1703BA/PL

badile antiscintilla

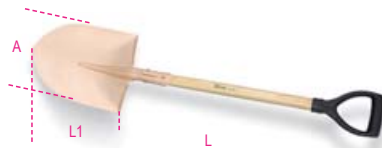

A mm	L1 mm	L mm	€	Icon	Icon
240	420	990	435,00	1	017030200

1717BA

spatole rigide, antiscintilla



A mm	€	Icon	Icon
60	106,00	1	017170801
80	118,00	1	017170803

1717BA/1

raschiapreti antiscintilla



A mm	L mm	€	Icon	Icon
100	220	212,00	1	017170805

1719BA8

lime da 8" antiscintilla

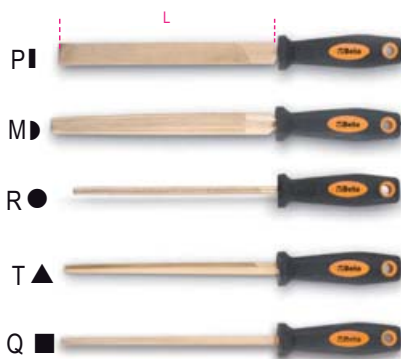

	L mm	€	Icon	Icon
1719BA8/P	200	130,00	1	017190801
1719BA8/M	200	135,00	1	017190805
1719BA8/R	200	138,00	1	017190810
1719BA8/T	200	127,00	1	017190815
1719BA8/Q	200	127,00	1	017190820

1719BA12

lima da 12" antiscintilla



	L mm	€	Icon	Icon
1719BA12/P	300	235,00	1	017190831

1727BA

seghetto e lama, antiscintilla



L mm	L1 mm	€	Icon	Icon
500	300	415,00	1	017270801

1728BA

lama per segchetti, antiscintilla



L mm	€	Icon	Icon
300	80,50	1	017280801

1737BA

spazzola con fili antiscintilla



L mm	A mm	€	Icon	Icon
294	29	54,00	1	017370801

1758BA

imbuto antiscintilla



Ø mm	H mm	€	Icon	Icon
160	150	75,00	1	017580815

1776BA

coltello antiscintilla



L1 mm	L mm	€	Icon	Icon
145	250	117,00	1	017760801

1784BA

forbici antiscintilla



L mm	€	Icon	Icon
225	203,00	1	017840822

1972/12

trapano avvitatore ultracompatto 12V

- **ultracompatto**, solo 176 mm di lunghezza , **ultraleggero**, solo 1,1 kg con batteria e **perfettamente bilanciato**
- doppia velocità meccanica con ingranaggi in acciaio e frizione a 18 posizioni
- coppia fino a 34 Nm e 1500 giri/min (350 giri/min in 1ª marcia); fora fino ad un diametro di 10 mm nell'acciaio e 20 mm nel legno
- batterie da 2Ah e indicatore di carica sul corpo macchina
- tripla autoprotezione della batteria (termica, sovraccarico e monitoraggio dell' eventuale disparità di carica fra le celle) offre una maggiore sicurezza e garantisce prestazioni elevate nel tempo
- impugnatura ergonomica antiscivolo
- LED frontale
- mandrino autoserrante da 10 mm
- clip da cintura destra/sinistra
- selettore avvita-svita-blocco (per il trasporto)
- fornito in valigetta rigida con 2 batterie agli ioni di litio da 2 Ah e caricatore rapido (45 min)

1,1 kg



1972/12

€ 320,00 1 019720012

1984/18QM

avvitatore reversibile ad impulsi 18V brushless

motore digitale senza spazzole brushless offre un notevole incremento delle prestazioni fra cui: maggiore potenza, minori consumi di energia, vita utile del motore estesa, estrema compattezza, miglior dosaggio della potenza dal pulsante.

- batterie da 5Ah con indicatore di carica
- ultracompatto: solo 196 mm di lunghezza
- attacco quadro maschio da 1/2" con anello trattieni-bussola
- clip da cintura destra/sinistra
- triplo LED di illuminazione frontale
- scatola ingranaggi interamente metallica
- selettore avvita-svita-blocco (per il trasporto)
- impugnatura ergonomica antiscivolo
- tripla autoprotezione della batteria (termica, sovraccarico e monitoraggio dell'eventuale disparità di carica fra le celle) offre una maggiore sicurezza e garantisce prestazioni elevate nel tempo

4 modalità selezionabili:

1: 270Nm; 1400 RPM

2: 360Nm; 2000 RPM

3: 450Nm; 2750 RPM

A: 450Nm Autostop - finché l'avvitatore rileva una rotazione libera applica il massimo della coppia/velocità (450Nm; 2750 RPM).

Quando il dado arriva a fine corsa e non ruota più, l'avvitatore continua ad applicare il massimo della coppia per 1 secondo poi si arresta.

- fornito in valigetta rigida con adattatore portainseri esagonale da 1/4", 2 batterie agli ioni di litio da 5 Ah e caricatore rapido (80 min)

2,3 kg



1984/18QM

€ 900,00 1 019840018



UTENSILI PNEUMATICI

Da oltre 20 anni Beta Utensili ha ampliato la propria offerta con una gamma completa di utensili pneumatici e accessori destinati al mercato automotive e alla manutenzione industriale: avvitatori, cricchetti, trapani, smerigliatrici, levigatrici e molti altri articoli. Nel corso di questo periodo la stretta collaborazione con gli utilizzatori professionisti è stata fondamentale per una crescita costante. È grazie a questa crescita che oggi il mercato riconosce negli utensili pneumatici Beta un ottimo rapporto affidabilità/prestazioni.

Beta Utensili, con l'obiettivo di soddisfare al meglio le richieste del mercato, effettua le riparazioni degli articoli pneumatici all'interno del proprio Ufficio Qualità. Questo processo ha consentito all'azienda di incrementare notevolmente il proprio know-how e di essere sempre più reattiva nei confronti della clientela.

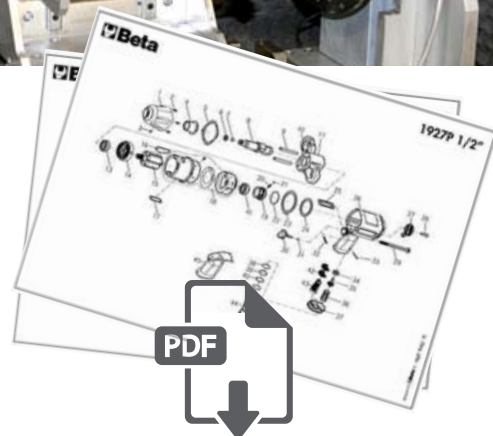
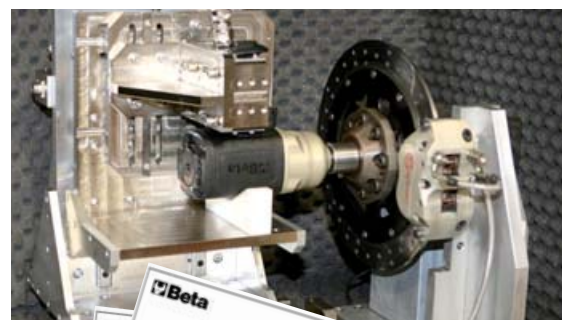

www.beta-tools.com













GUIDA ALLA SCELTA UTENSILI PNEUMATICI

GAMMA AVVITATORI







■	ARTICOLO	CODICE	MATERIALE	 max. Nm	 db (A) LpA	 db (A) LpW	 l/min.	 kg	MECCANISMO	 m/s ²
3/8"		1924F	Alluminio	108	93.6	104.6	59	0,5	Doppio martello	6.85
3/8"		1924B	Alluminio	353	91	95	80	1,5	Pin clutch	7.9
3/8"		1924CD	Composito	410	91.7	102.7	79	1,3	Doppio martello	6.2
1/2"		1927AN	Alluminio	244	89.4	100.4	190	2,1	Singolo martello	8.63
1/2"		1927G	Alluminio	325	92.2	103.2	113	1,2	Singolo martello	9.96
1/2"		1927B	Alluminio	705	98.0	109.0	133	2,1	Pin clutch	14.08
1/2"		1927XM	Alluminio	770	102	113	122	1,3	Singolo martello	7.5
1/2"		1927CD	Composito	1.020	95.5	106.5	130	2,3	Doppio martello	7.2
1/2"		1927P	Composito	1.750	95.1	106.1	290	2,0	Doppio martello	6.7
3/4"		1928XM	Alluminio	1.600	91.8	102.8	175	2,9	Doppio martello	12.96
3/4"		1928DA	Alluminio	1.695	96	99.5	300	4,3	Doppio martello	3.6
3/4"		1928DAL	Alluminio	1.695	96	99.5	300	4,8	Doppio martello	3.6
3/4"		1928CD	Composito	1.800	97.5	108.5	215	3,5	Doppio martello	11.4
1"		1930CD	Composito	2.445	95.6	97.1	410	7,1	Doppio martello	3,6
1"		1930PA	Alluminio	2.445	96.0	97.1	410	9,6	Doppio martello	7,2
1"		1930A	Alluminio	2.445	103.3	114.3	460	9,5	Doppio martello	67
1"		1930LH	Alluminio	2.441	97.1	108.1	282	7,1	Doppio martello	17.4
1"		1930LA	Alluminio	2.445	95.6	97.1	460	10,6	Doppio martello	3,6
1"		1930HLA	Alluminio	3.661	99	101	460	16,4	Doppio martello	16,4
1 1/2"		1930ZL	Alluminio	4.068	102.4	113.4	480	15	Doppio martello	69.6

GUIDA ALLA SCELTA UTENSILI PNEUMATICI

GAMMA AVVITATORI A CRICCHETTO

■	ARTICOLO	CODICE	 max. Nm	 db (A) LpA	 db (A) LpW	 l/min.	 kg	 m/s ²
1/4"		1921B1	24	96	85	90	0,4	2.6
1/4"		1921M1	27	84	88	96	0,6	1.8
1/4"		1922P1	68	90.6	101.6	88	0,6	8.61
3/8"		1921M2	27	84	88	96	0,6	1.8
3/8"		1922P2	68	90.6	101.6	88	0,6	8.61
1/2"		1921N3	68	80	87	140	1,2	2.6
1/2"		1922P3	136	94.9	105.9	113	1,5	18.28

GAMMA SMERIGLIATRICI

	ARTICOLO	CODICE	POTENZA	 db (A) LpA	 db (A) LpW	 l/min.	 kg	 m/s ²
		1933	0,20 kW	80.0	87.0	230	0,38	4.53
		1933L	0,20 kW	80.0	87.0	270	0,67	1.15
		1933AN90	0,20 kW	80.0	87.0	230	0,51	1.24
		1933I	0,38 kW	80.0	87.0	260	0,67	4.53
		1933IL	0,38 kW	79.0	97.0	113	1,4	1.6
		1933IH	0,75 kW	88.1	99.1	370	0,8	2.6
		1933ILH	0,75 kW	85.7	96.7	370	1,2	1.4
		1933AN90-H	0,75 kW	85.6	96.6	370	1,1	6.7
		1934MAV	0,04 kW	71	76	115	0,2	2.5
		1934MAV70	0,08 kW	80	87	115	0,2	4

1921B1

baby cricchetto reversibile

1/4"

CE



Velocità libera	350 giri/min
Coppia massima	24 Nm
Capacità vite/dado	CI 8.8 M7●11 mm
Capacità vite/dado	CI 12.9 M6●10 mm
Attacco aria	1/4" GAS
Pressione di utilizzo	6,2 bar
Ø interno tubo aria	8 mm
Consumo aria medio	68 l/min
Peso	0,4 kg

1/4	kg	€	1	019210001
		208,00		

1921N3

cricchetto reversibile

1/2"

CE



Velocità libera	150 giri/min
Coppia massima	68 Nm
Capacità vite/dado	CI 8.8 M10●16 mm
Capacità vite/dado	CI 12.9 M8●13 mm
Attacco aria	1/4" GAS
Pressione di utilizzo	6,2 bar
Ø interno tubo aria	10 mm
Consumo aria medio	140 l/min
Peso	1,2 kg

1/2	kg	€	1	019210025
	1,2	184,00		

1922P3

cricchetto reversibile a massa battente

1/2"

CE



Velocità libera	600 giri/min
Coppia massima	136 Nm
Capacità vite/dado	CI 8.8 M12●18 mm
Capacità vite/dado	CI 12.9 M10●16 mm
Attacco aria	1/4" GAS
Pressione di utilizzo	6,2 bar
Ø interno tubo aria	10 mm
Consumo aria medio	113 l/min
Peso	1,5 kg

1/2	kg	€	1	019220013
	1,5	351,00		

1921M1

cricchetto compatto reversibile

1/4"

CE



Velocità libera	200 giri/min
Coppia massima	27 Nm
Capacità vite/dado	CI 8.8 M7●11 mm
Capacità vite/dado	CI 12.9 M6●10 mm
Attacco aria	1/4" GAS
Pressione di utilizzo	6,2 bar
Ø interno tubo aria	8 mm
Consumo aria medio	96 l/min
Peso	0,6 kg

1/4	kg	€	1	019210005
	0,6	184,00		

1922P1

cricchetto reversibile a massa battente

1/4"

CE



Velocità libera	700 giri/min
Coppia massima	68 Nm
Capacità vite/dado	CI 8.8 M10●16 mm
Capacità vite/dado	CI 12.9 M8●13 mm
Attacco aria	1/4" GAS
Pressione di utilizzo	6,2 bar
Ø interno tubo aria	10 mm
Consumo aria medio	88 l/min
Peso	0,6 kg

1/4	kg	€	1	019220006
	0,6	223,00		

1924F

avvitatore reversibile compatto "butterfly"

3/8"

CE



Velocità libera	12.000 giri/min
Coppia massima	108 Nm
Capacità vite/dado	CI 8.8 M12●18 mm
Capacità vite/dado	CI 12.9 M10●16 mm
Attacco aria	1/4" GAS
Pressione di utilizzo	6,2 bar
Ø interno tubo aria	10 mm
Consumo aria medio	59 l/min
Peso	0,5 kg

3/8	kg	€	1	019240025
	0,5	207,00		

1921M2

cricchetto compatto reversibile

3/8"

CE



Velocità libera	200 giri/min
Coppia massima	27 Nm
Capacità vite/dado	CI 8.8 M7●11 mm
Capacità vite/dado	CI 12.9 M6●10 mm
Attacco aria	1/4" GAS
Pressione di utilizzo	6,2 bar
Ø interno tubo aria	8 mm
Consumo aria medio	96 l/min
Peso	0,6 kg

3/8	kg	€	1	019210015
	0,6	184,00		

1922P2

cricchetto reversibile a massa battente

3/8"

CE



Velocità libera	700 giri/min
Coppia massima	68 Nm
Capacità vite/dado	CI 8.8 M10●16 mm
Capacità vite/dado	CI 12.9 M8●13 mm
Attacco aria	1/4" GAS
Pressione di utilizzo	6,2 bar
Ø interno tubo aria	10 mm
Consumo aria medio	88 l/min
Peso	0,6 kg

3/8	kg	€	1	019220010
	0,6	223,00		



1924B

avvitatore reversibile compatto

- Meccanismo impulsivo "Pin Clutch"



Velocità libera	10.000 giri/min
Coppia massima	353 Nm
Capacità vite/dado	CI 8.8 M16 ● 24 mm
Capacità vite/dado	CI 12.9 M14 ● 21 mm
Attacco aria	1/4" GAS
Pressione di utilizzo	6,2 bar
Ø interno tubo aria	8 mm
Consumo aria medio	80 l/min
Peso	1,5 kg

3/8 kg 1,5 € 238,00 1 019240021

1927CD

avvitatore reversibile in materiale composito

- Meccanismo impulsivo doppio martello



Velocità libera	7.000 giri/min
Coppia massima	1.020 Nm
Capacità vite/dado	CI 8.8 M22 ● 34 mm
Capacità vite/dado	CI 12.9 M18 ● 27 mm
Attacco aria	1/4" GAS
Pressione di utilizzo	6,2 bar
Ø interno tubo aria	10 mm
Consumo aria medio	130 l/min
Peso	2,3 kg

1/2 kg 2,3 € 375,00 1 019270007

1927XM

avvitatore reversibile compatto

- Meccanismo impulsivo singolo martello



Velocità libera	10.000 giri/min
Coppia massima	770 Nm
Capacità vite/dado	CI 8.8 M22 ● 34 mm
Capacità vite/dado	CI 12.9 M18 ● 27 mm
Attacco aria	1/4" GAS
Pressione di utilizzo	6,2 bar
Ø interno tubo aria	10 mm
Consumo aria medio	122 l/min
Peso	1,3 kg

1/2 kg 1,3 € 243,00 1 019270030

1924CD

avvitatore reversibile in materiale composito

- Meccanismo impulsivo doppio martello



Velocità libera	10.000 giri/min
Coppia massima	410 Nm
Capacità vite/dado	CI 8.8 M16 ● 24 mm
Capacità vite/dado	CI 12.9 M14 ● 21 mm
Attacco aria	1/4" GAS
Pressione di utilizzo	6,2 bar
Ø interno tubo aria	8 mm
Consumo aria medio	79 l/min
Peso	1,3 kg

3/8 kg 1,3 € 324,00 1 019240007

1927P

avvitatore reversibile in materiale composito

- Meccanismo impulsivo doppio martello



Velocità libera	7.500 giri/min
Coppia massima	1.750 Nm
Capacità vite/dado	CI 8.8 M24 ● 36 mm
Capacità vite/dado	CI 12.9 M20 ● 30 mm
Attacco aria	1/4" GAS
Pressione di utilizzo	6,2 bar
Ø interno tubo aria	10 mm
Consumo aria medio	290 l/min
Peso	2 kg

1/2 kg 2,0 € 410,00 1 019270008

1927B

avvitatore reversibile

- Meccanismo impulsivo "Pin Clutch"



Velocità libera	7.000 giri/min
Coppia massima	705 Nm
Capacità vite/dado	CI 8.8 M22 ● 34 mm
Capacità vite/dado	CI 12.9 M18 ● 27 mm
Attacco aria	1/4" GAS
Pressione di utilizzo	6,2 bar
Ø interno tubo aria	10 mm
Consumo aria medio	133 l/min
Peso	2,1 kg

1/2 kg 2,1 € 160,00 1 019270022

1927AN

avvitatore reversibile angolare

- Meccanismo impulsivo singolo martello

1/2"

CE



Velocità libera	4.700 giri/min
Coppia massima	244 Nm
Capacità vite/dado	CI 8.8 M14●21 mm
Capacità vite/dado	CI 12.9 M12●19 mm
Attacco aria	1/4" GAS
Pressione di utilizzo	6,2 bar
Ø interno tubo aria	10 mm
Consumo aria medio	190 l/min
Peso	2,1 kg

1/2"	kg	€	1	019270012
	2,1	430,00		

1927G

avvitatore reversibile compatto

- Meccanismo impulsivo singolo martello

1/2"

CE



Velocità libera	8500 giri/min
Coppia massima	325 Nm
Capacità vite/dado	CI 8.8 M16●24 mm
Capacità vite/dado	CI 12.9 M14●21 mm
Attacco aria	1/4" GAS
Pressione di utilizzo	6,2 bar
Ø interno tubo aria	10 mm
Consumo aria medio	113 l/min
Peso	1,2 kg

1/2"	kg	€	1	019270050
	1,2	354,00		

1927SP-AM

supporto magnetico per avvitatore pneumatico

- Dotato di due magneti ad alta tenuta con gomma protettiva
- Permette di alloggiare 1 avvitatore da 1/2", 4 bussole e 1 chiave dinamometrica
- Portata: 10 kg



g	€	1	019270000
400	48,50		

1928KM

avvitatore reversibile compatto

- Meccanismo impulsivo doppio martello
- Incredibilmente compatto e potente
- Comando d'inversione a leva azionabile con una sola mano
- Tre differenti livelli di potenza in avvitamento
- Scarico dell'aria attraverso l'impugnatura

3/4"

CE



Velocità libera	4.800 giri/min
Coppia massima	1.600 Nm
Capacità vite/dado	CI 8.8 M27●41 mm
Capacità vite/dado	CI 12.9 M24●36 mm
Attacco aria	3/8" GAS
Pressione di utilizzo	6,2 bar
Ø interno tubo aria	10 mm
Consumo aria medio	175 l/min
Peso	2,9 kg

3/4"	kg	€	1	019280030
	2,9	483,00		

1928CD

avvitatore reversibile in materiale composito

- Meccanismo impulsivo doppio martello

3/4"

CE



Velocità libera	4.500 giri/min
Coppia massima	1.800 Nm
Capacità vite/dado	CI 8.8 M27●41 mm
Capacità vite/dado	CI 12.9 M24●36 mm
Attacco aria	3/8" GAS
Pressione di utilizzo	6,2 bar
Ø interno tubo aria	10 mm
Consumo aria medio	215 l/min
Peso	3,5 kg

3/4"	kg	€	1	019280007
	3,5	897,00		

1928DA

avvitatore reversibile

- Meccanismo impulsivo doppio martello

3/4"

CE



Velocità libera	5.000 giri/min
Coppia massima	1.695 Nm
Capacità vite/dado	CI 8.8 M30●46 mm
Capacità vite/dado	CI 12.9 M27●41 mm
Attacco aria	3/8" GAS
Pressione di utilizzo	6,2 bar
Ø interno tubo aria	10 mm
Consumo aria medio	240 l/min
Peso	4,3 kg

3/4"	kg	€	1	019280022
	4,3	699,00		

1928DAL

avvitatore reversibile

- Meccanismo impulsivo doppio martello

3/4"

CE



Velocità libera	5.000 giri/min
Coppia massima	1.695 Nm
Capacità vite/dado	CI 8.8 M27●41 mm
Capacità vite/dado	CI 12.9 M24●36 mm
Attacco aria	3/8" GAS
Pressione di utilizzo	6,2 bar
Ø interno tubo aria	10 mm
Consumo aria medio	240 l/min
Peso	4,8 kg

3/4"	kg	€	1	019280023
	4,8	749,00		

1928K4

assortimento di un avvitatore reversibile e quattro bussole Macchina serie lunga

- Meccanismo impulsivo "Pin Clutch"

3/4"
CE



728L 27-30-32-36 mm

Velocità libera	4.000 giri/min
Coppia massima	1.493 Nm
Capacità vite/dado	Cl 8.8 M27 ● 41 mm
Capacità vite/dado	Cl 12.9 M24 ● 36 mm
Attacco aria	3/8" GAS BSP
Pressione di utilizzo	6,2 bar
Ø interno tubo aria	10 mm
Consumo aria medio	260 l/min
Peso avvitatore	5,2 kg

3/4" 9,3 € 713,00 1 019280104
410x330x106 mm

1930LH

avvitatore reversibile

- Meccanismo impulsivo doppio martello

1"
CE



Velocità libera	6.000 giri/min
Coppia massima	2.441 Nm
Capacità vite/dado	Cl 8.8 M36 ● 55 mm
Capacità vite/dado	Cl 12.9 M30 ● 46 mm
Attacco aria	1/2" GAS
Pressione di utilizzo	6,2 bar
Ø interno tubo aria	13 mm
Consumo aria medio	280 l/min
Peso	7,1 kg

1" 7,1 € 1.080,00 1 019300030

1930LA

avvitatore reversibile

- Meccanismo impulsivo doppio martello

1"
CE



Velocità libera	4.000 giri/min
Coppia massima	2.445 Nm
Capacità vite/dado	Cl 8.8 M36 ● 55 mm
Capacità vite/dado	Cl 12.9 M30 ● 46 mm
Attacco aria	1/2" GAS
Pressione di utilizzo	6,2 bar
Ø interno tubo aria	13 mm
Consumo aria medio	460 l/min
Peso	10,6 kg

1" 10,6 € 1.100,00 1 019300037

1930CD

avvitatore reversibile in materiale composito

- Meccanismo impulsivo doppio martello

1"
CE



Velocità libera	4.000 giri/min
Coppia massima	2.445 Nm
Capacità vite/dado	Cl 8.8 M36 ● 55 mm
Capacità vite/dado	Cl 12.9 M30 ● 46 mm
Attacco aria	1/2" GAS
Pressione di utilizzo	6,2 bar
Ø interno tubo aria	13 mm
Consumo aria medio	320 l/min
Peso	7,1 kg

1" 7,1 € 1.155,00 1 019300022

1930PA

avvitatore reversibile

- Meccanismo impulsivo doppio martello

1"
CE



Velocità libera	3.500 giri/min
Coppia massima	2.445 Nm
Capacità vite/dado	Cl 8.8 M36 ● 55 mm
Capacità vite/dado	Cl 12.9 M30 ● 46 mm
Attacco aria	1/2" GAS
Pressione di utilizzo	6,2 bar
Ø interno tubo aria	13 mm
Consumo aria medio	350 l/min
Peso	9,6 kg

1" 9,6 € 1.045,00 1 019300032

1930A

avvitatore reversibile

- Meccanismo impulsivo doppio martello

1"
CE



Velocità libera	4.000 giri/min
Coppia massima	2.445 Nm
Capacità vite/dado	Cl 8.8 M36 ● 55 mm
Capacità vite/dado	Cl 12.9 M30 ● 46 mm
Attacco aria	1/2" GAS
Pressione di utilizzo	6,2 bar
Ø interno tubo aria	13 mm
Consumo aria medio	460 l/min
Peso	9,5 kg

1" 9,5 € 1.055,00 1 019300036

1930HLA

avvitatore reversibile

• Meccanismo impulsivo doppio martello

1"
CE



Velocità libera	3.000 giri/min
Coppia massima	3.661 Nm
Capacità vite/dado	Cl 8.8 M42●65 mm
Capacità vite/dado	Cl 12.9 M33●50 mm
Attacco aria	1/2" GAS
Pressione di utilizzo	6,2 bar
Ø interno tubo aria	13 mm
Consumo aria medio	460 l/min
Peso	16,4 kg

■	kg	€	1	019300040
1	16,4	1.520,00		

1931CD6

trapano reversibile in composito

CE



Velocità libera	2.600 giri/min
Capacità mandrino	1÷6 mm
Potenza	0,23 kW
Filettatura albero	3/8" - 24UNF
Attacco aria	1/4" GAS
Pressione di utilizzo	6,2 bar
Ø interno tubo aria	8 mm
Consumo aria medio	130 l/min
Peso	0,6 kg

■	kg	€	1	019310006
0,6		220,00		

1931CD13

trapano reversibile in composito

CE



Velocità libera	800 giri/min
Capacità mandrino	1,0÷13 mm
Potenza	0,38 kW
Filettatura albero	1/2" - 20UNC
Attacco aria	1/4" GAS
Pressione di utilizzo	6,2 bar
Ø interno tubo aria	10 mm
Consumo aria medio	170 l/min
Peso	1,3 kg

■	kg	€	1	019310013
1,3		294,00		

1930ZL

avvitatore reversibile

• Meccanismo impulsivo doppio martello

1 1/2"
CE



Velocità libera	3.000 giri/min
Coppia massima	4.068 Nm
Capacità vite/dado	Cl 8.8 M42●65 mm
Capacità vite/dado	Cl 12.9 M36●55 mm
Attacco aria	1/2" GAS
Pressione di utilizzo	6,2 bar
Ø interno tubo aria	13 mm
Consumo aria medio	480 l/min
Peso	15 kg

■	kg	€	1	019300070
1 1/2	15	1.915,00		

1931CD10

trapano reversibile in composito

CE



Velocità libera	1.800 giri/min
Capacità mandrino	1÷10 mm
Potenza	0,38 kW
Filettatura albero	3/8" - 24UNF
Attacco aria	1/4" GAS
Pressione di utilizzo	6,2 bar
Ø interno tubo aria	10 mm
Consumo aria medio	170 l/min
Peso	1,0 kg

■	kg	€	1	019310010
1,0		198,00		

1931AN10

trapano angolare reversibile

CE



Velocità libera	1.400 giri/min
Capacità mandrino	1÷10 mm
Potenza	0,38 kW
Filettatura albero	3/8" - 24UNF
Attacco aria	1/4" GAS
Pressione di utilizzo	6,2 bar
Ø interno tubo aria	10 mm
Consumo aria medio	150 l/min
Peso	1,1 kg

■	kg	€	1	019310030
1,1		220,00		

1932B10

trapano reversibile



Velocità libera	1.800 giri/min
Capacità mandrino	1÷10 mm
Potenza	0,44 kW
Filettatura albero	3/8" - 24UNF
Attacco aria	1/4" GAS
Pressione di utilizzo	6,2 bar
Ø interno tubo aria	10 mm
Consumo aria medio	160 l/min
Peso	1,2 kg

kg 1,2 € 157,00 1 019320040

1932RS13

trapano reversibile



Velocità libera	750 giri/min
Capacità mandrino	1,5÷13 mm
Potenza	0,55 kW
Filettatura albero	3/8" - 24UNF
Attacco aria	1/4" GAS
Pressione di utilizzo	6,2 bar
Ø interno tubo aria	10 mm
Consumo aria medio	160 l/min
Peso	1,4 kg

kg 1,4 € 200,00 1 019320043

1932B13

trapano reversibile



Velocità libera	400 giri/min
Capacità mandrino	1,5÷13 mm
Potenza	0,34 kW
Filettatura albero	1/2" - 20UNC
Attacco aria	1/4" GAS
Pressione di utilizzo	6,2 bar
Ø interno tubo aria	10 mm
Consumo aria medio	180 l/min
Peso	1,6 kg

kg 1,6 € 235,00 1 019320004

1933IH

smerigliatrice assiale alta potenza

• Fornita con pinza di Ø 3 e 6 mm



Velocità libera	20.000 giri/min
Capacità pinza	3 - 6 mm
Potenza	0,75 kW
Attacco aria	1/4" GAS
Pressione di utilizzo	6,2 bar
Ø interno tubo aria	10 mm
Consumo aria medio	370 l/min
Peso	800 g

g 800 € 178,00 1 019330006

1933ILH

smerigliatrice assiale alta potenza con albero prolungato

• Fornita con pinza di Ø 3 e 6 mm

CE



Velocità libera	20.000 giri/min
Capacità pinza	3 - 6 mm
Potenza	0,75 kW
Attacco aria	1/4" GAS
Pressione di utilizzo	6,2 bar
Ø interno tubo aria	10 mm
Consumo aria medio	370 l/min
Peso	1,2 kg

kg 1,2 € 335,00 1 019330011

1933AN90-H

smerigliatrice angolare alta potenza

• Fornita con pinza di Ø 3 e 6 mm

CE



Velocità libera	15.000 giri/min
Capacità pinza	3 - 6 mm
Potenza	0,75 kW
Attacco aria	1/4" GAS
Pressione di utilizzo	6,2 bar
Ø interno tubo aria	10 mm
Consumo aria medio	370 l/min
Peso	1,1 kg

kg 1,1 € 335,00 1 019330021

1933

smerigliatrice assiale

• Fornita con pinza di Ø 3 e 6 mm

CE



Velocità libera	25.000 giri/min
Capacità pinza	3 - 6 mm
Potenza	0,20 kW
Attacco aria	1/4" GAS
Pressione di utilizzo	6,2 bar
Ø interno tubo aria	10 mm
Consumo aria medio	230 l/min
Peso	380 g

g 380 € 117,00 1 019330001

Beta
Quality Tools

1933I

smerigliatrice assiale

• Fornita con pinza di Ø 3 e 6 mm

CE



Velocità libera	20.000 giri/min
Capacità pinza	3 - 6 mm
Potenza	0,38 kW
Attacco aria	1/4" GAS
Pressione di utilizzo	6,2 bar
Ø interno tubo aria	10 mm
Consumo aria medio	260 l/min
Peso	670 g

g 670 € 133,00 1 019330005

1933L

smerigliatrice assiale con albero prolungato

• Fornita con pinza di Ø 3 e 6 mm

CE



Velocità libera	25.000 giri/min
Capacità pinza	3 - 6 mm
Potenza	0,20 kW
Attacco aria	1/4" GAS
Pressione di utilizzo	6,2 bar
Ø interno tubo aria	10 mm
Consumo aria medio	270 l/min
Peso	670 g

g 670 € 149,00 1 019330015

1933IL

smerigliatrice assiale con albero prolungato

• Fornita con pinza di Ø 3 e 6 mm

CE



Velocità libera	20.000 giri/min
Capacità pinza	3 - 6 mm
Potenza	0,38 kW
Attacco aria	1/4" GAS
Pressione di utilizzo	6,2 bar
Ø interno tubo aria	10 mm
Consumo aria medio	113 l/min
Peso	1,4 kg

kg 1,4 € 181,00 1 019330010

1933AN90

smerigliatrice angolare

• Fornita con pinza di Ø 3 e 6 mm

CE



Velocità libera	20.000 giri/min
Capacità pinza	3 - 6 mm
Potenza	0,20 kW
Attacco aria	1/4" GAS
Pressione di utilizzo	6,2 bar
Ø interno tubo aria	10 mm
Consumo aria medio	230 l/min
Peso	510 g

g 510 € 149,00 1 019330020

1934BV

pulitrice a basse velocità

• Fornita con pinza di Ø 3 e 6 mm

CE



Velocità libera	3.700 giri/min
Capacità pinza	3 - 6 mm
Potenza	0,37 kW
Attacco aria	1/4" GAS
Pressione di utilizzo	6,2 bar
Ø interno tubo aria	10 mm
Consumo aria medio	113 l/min
Peso	840 g

g 840 € 162,00 1 019340000



1934MAV

microsmerigliatrice assiale

CE



Velocità libera	56.000 giri/min
Capacità pinza	3 mm
Potenza	0,04 kW
Attacco aria	1/4" GAS BSPT
Pressione di utilizzo	6,2 bar
Ø interno tubo aria	4,5 mm
Consumo aria medio	115 l/min
Peso	205 g

g 205 € 139,00 1 019340010

1934MAV70

microsmerigliatrice assiale ad alta velocità

CE



Velocità libera	70.000 giri/min
Capacità pinza	3 mm
Potenza	0,08 kW
Attacco aria	1/4" GAS BSPT
Pressione di utilizzo	6,2 bar
Ø interno tubo aria	4,5 mm
Consumo aria medio	115 l/min
Peso	210 g

g 210 € 230,00 1 019340030

1935F

giravite reversibile

1/4

CE



4-16 Nm

Velocità libera	800 giri/min
Campo di coppia	4-16 Nm
Capacità vite	6-9 M
Porta inserti	● 1/4"
Attacco aria	1/4" GAS
Pressione di utilizzo	6,2 bar
Ø interno tubo aria	10 mm
Consumo aria medio	150 l/min
Peso	1,3 kg

kg 1,3 € 220,00 1 019350045

1936/4A

smerigliatrice angolare

CE



Velocità libera	11.000 giri/min
Dimensione mola	115 mm
Potenza	0,66 kW
Filettatura albero	M14
Attacco aria	1/4" GAS
Pressione di utilizzo	6,2 bar
Ø interno tubo aria	10 mm
Consumo aria medio	390 l/min
Peso	1,8 kg

kg 1,8 € 361,00 1 019360024

1936/5A

smerigliatrice angolare

CE



Velocità libera	10.000 giri/min
Dimensione mola	125 mm
Potenza	0,66 kW
Filettatura albero	M14
Attacco aria	1/4" GAS
Pressione di utilizzo	6,2 bar
Ø interno tubo aria	10 mm
Consumo aria medio	390 l/min
Peso	1,9 kg

kg 1,9 € 361,00 1 019360025

1936/7A

smerigliatrice angolare



Velocità libera	7600 giri/min
Dimensione mola	180 mm
Potenza	1,3 kW
Filettatura albero	M14
Attacco aria	3/8" GAS
Pressione di utilizzo	6,2 bar
Ø interno tubo aria	13 mm
Consumo aria medio	906 l/min
Peso	2,7 kg

kg 2,7 € 530,00 1 019360027

1937 2,5

levigatrice rotorbitale palmare senza lubrificazione, in composito

• Diametro orbita 2,5 mm

CE



Velocità libera	12.000 giri/min
Potenza	0,18 kW
Dimensione platorello	150 mm
Diametro orbita	2,5 mm
Filettatura albero	5/16"-24
Attacco aria	1/4" GAS
Pressione di utilizzo	6,2 bar
Ø interno tubo aria	10 mm
Consumo aria medio	170 l/min
Peso	0,86 kg

kg 0,86 € 383,00 1 019370000

1937

levigatrice rotorbitale palmare senza lubrificazione, in composito

• Diametro orbita 5 mm

CE



Velocità libera	12.000 giri/min
Potenza	0,18 kW
Dimensione platorello	150 mm
Diametro orbita	5 mm
Filettatura albero	5/16"-24
Attacco aria	1/4" GAS
Pressione di utilizzo	6,2 bar
Ø interno tubo aria	10 mm
Consumo aria medio	170 l/min
Peso	0,86 kg

kg 0,86 € 383,00 1 019370001

1937R/P

platorello Ø 150 mm 6 fori per 1937



1937R/P € 40,00 1 019370002



1937KC

mini levigatrice rotorbitale

- Diametro orbita 4 mm
- 2 plattrelli di levigatura Ø 50 mm e Ø 75 mm
- 10 dischi carta abrasiva Ø 50 mm grana 400, 600, 800
- 10 dischi carta abrasiva Ø 75 mm grana 400, 600, 800

CE



Velocità libera	15000 giri/min
Potenza	0,25 kW
Dimensione plattello	50 - 75 mm
Filettatura albero	M6 x 1,0
Attacco aria	1/4" GAS BSPT
Pressione utilizzo	6,2 bar
Ø interno tubo aria	10 mm
Consumo aria medio	79 l/min
Peso lucidatrice	0,64 kg
Peso kit	1,4 kg

kg	€		
1,4	219,00	1	019370171

1937C...

dischi carta abrasiva per 1937KC



Ø mm	P	€		
50	400	13,00	1	019370175
50	600	13,00	1	019370176
50	800	13,00	1	019370177
75	400	16,50	1	019370178
75	600	16,50	1	019370179
75	800	16,50	1	019370180

* I prezzi indicati sono relativi a 10 pezzi

Beta

Quality Tools

1937KL

mini lucidatrice

- Plattello di levigatura Ø 75 mm
- 2 spugne di lucidatura Ø 90mm - 1937/KL-DSB, 1937/KL-DSG
- Lana d'agnello Ø 90 mm - 1937/KL-DLA

CE



Velocità libera	3.200 giri/min
Potenza	0,25 kW
Dimensione plattello	75 mm
Filettatura albero	M6
Attacco aria	1/4" GAS BSPT
Pressione di utilizzo	6,2 bar
Ø interno tubo aria	10 mm
Consumo aria medio	91 l/min
Peso lucidatrice	0,75 kg
Peso kit	1,8 kg

kg	€		
1,8	239,00	1	019370161

1937KL-D

accessori per 1937KL



	Ø mm	€		
1937KL-DLA	90	21,50	1	019370164
1937KL-DSB	90	21,50	1	019370165
1937KL-DSG	90	21,50	1	019370166

1937K...

plattrelli per 1937KC e 1937KL



	Ø mm		€		
1937KC-RP	50	•	23,50	1	019370173
1937KL-RP	75	• •	28,50	1	019370163

1937RT

levigatrice orbitale palmare in composito, con aspirazione

- Diametro orbita 5 mm
- Plattello rettangolare (100x110 mm)
- Plattello a Delta (125x95 mm)

CE



Velocità libera	10.000 giri/min
Diametro orbita	5 mm
Attacco aria	1/4" GAS
Pressione di utilizzo	6,2 bar
Ø interno tubo aria	10 mm
Consumo aria medio	180 l/min
Peso	0,9 kg

kg	€		
0,9	395,00	1	019370021

1937RT/R

plattello rettangolare per 1937RT



	L mm	L1 mm	€		
1937RT/R	110	100	30,50	1	019370022

1937RT/T

plattello a Delta per 1937RT



	L mm	L1 mm	€		
1937RT/T	125	95	29,00	1	019370023

Beta

Beta

1937M

levigatrice multifunzione
con 16 accessori

CE



Velocità libera	3.500 giri/min
Potenza	0,34 kW
Attacco aria	1/4" GAS
Pressione di utilizzo	6,2 bar
Ø interno tubo aria	10 mm
Consumo aria medio	113 l/min
Peso levigatrice	1,5 kg
Peso kit	4,5 kg

kg	€	1	019370011
4,5	654,00		
458x495x116 mm			

1937M-01÷11

accessori per 1937M



L mm	1937M-	€	1	019370101
30		24,50		
30		24,50		
11		21,50		
23		21,50		
11		21,50		
23		21,50		
16		59,00		
13	07	21,50		
26	07	21,50		
11	03, 05	21,50		
23	01, 02, 04, 06	21,50		

* I prezzi indicati sono relativi a 6 pezzi

1937N10

levigatrice a nastro

CE



Velocità libera	20.000 giri/min
Potenza	0,37 kW
Dimensioni nastro	10x330 mm
Attacco aria	1/4" GAS
Pressione di utilizzo	6,2 bar
Ø interno tubo aria	10 mm
Consumo aria medio	374 l/min
Peso	0,9 kg

kg	€	1	019370041
0,9	257,00		

1937N10-GR

nastri abrasivi per 1937N10



	P	€	1	019370146
1937N10-GR60	60	27,00		
1937N10-GR80	80	27,00		
1937N10-GR100	100	27,00		
1937N10-GR120	120	27,00		

I prezzi indicati sono relativi a 10 pezzi

1937N20

levigatrice a nastro

CE



Velocità libera	16.000 giri/min
Potenza	0,45 kW
Dimensioni nastro	20x520 mm
Attacco aria	1/4" GAS
Pressione di utilizzo	6,2 bar
Ø interno tubo aria	10 mm
Consumo aria medio	400 l/min
Peso	1,6 kg

kg	€	1	019370051
1,6	298,00		

1937N20-GR

nastri abrasivi per 1937N20



	P	€	1	019370156
1937N20-GR60	60	35,00		
1937N20-GR80	80	35,00		
1937N20-GR100	100	35,00		
1937N20-GR120	120	35,00		

I prezzi indicati sono relativi a 10 pezzi

1938

staccavetri

• Fornito con 1 lama dritta da 57 mm

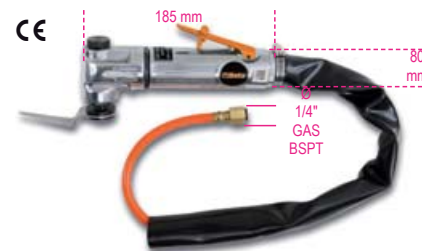

Oscillazioni al minuto	20.000
Attacco aria	1/4" GAS
Pressione di utilizzo	6,2 bar
Ø interno tubo aria	6,5 mm
Consumo aria medio	200 l/min
Peso	1,0 kg

kg	€	1	019380021
1,0	202,00		

1938R/L

lame per staccavetri



	L mm	€	1	019380041
1938R/L1	57	17,00		
1938R/L2	90	31,50		
1938R/L3	50	19,00		
1938R/L4	16	27,00		
1938R/L5	36	31,00		

1938R/S5

serie di 5 lame per staccavetri 1938

kg	€	1	019380055
	125,50		

1940

martello scalpellatore

- Fornito con molla di ritegno e trattenitore di sicurezza a baionetta per punte esagonali

11

CE



Colpi al minuto	3.500
Dimensione attacco	○ 11 mm
Dimensione pistone	19 mm
Corsa del pistone	67 mm
Attacco aria	1/4" GAS
Pressione di utilizzo	6,2 bar
Ø interno tubo aria	8 mm
Consumo aria medio	240 l/min
Peso	1,9 kg

kg	€		
1,9	162,00	1	019400001

1940MT

molla di tenuta per 1940



1940MT	€ 10,50	5	019400110
--------	---------	---	-----------

1940S...

scalpelli per martelli scalpellatori 1940



1940SN	€ 13,00	5	019400020
1940ST	13,00	5	019400021
1940SD	13,00	5	019400022
1940SPS	13,00	5	019400023
1940SDT	13,00	5	019400024

1940/S5

serie di 5 scalpelli per martelli scalpellatori 1940



1940/S5	€ 59,00	1	019400030
---------	---------	---	-----------

1940E10

martello scalpellatore

- Compatibile con scalpelli con attacco esagonale da 10mm
- fornito con molla di ritegno e trattenitore di sicurezza a baionetta

CE

10



Colpi al minuto	2.900
Dimensione attacco	○ 10 mm
Dimensione pistone	19 mm
Corsa del pistone	67 mm
Attacco aria	1/4" GAS
Pressione di utilizzo	6,2 bar
Ø interno tubo aria	10 mm
Consumo aria medio	76 l/min
Peso	1,7 kg

kg	€		
1,7	178,00	1	019400010

1940E10/MT

molla di tenuta per 1940E10



1940E10/MT	€ 1,40	5	019400112
------------	--------	---	-----------

1940E10/S...

scalpelli per martelli scalpellatori 1940E10



1940E10/SN	€ 9,00	5	019400040
1940E10/ST	9,00	5	019400041
1940E10/SD	9,00	5	019400042
1940E10/SPS	9,00	5	019400043
1940E10/SDT	9,00	5	019400044

1940E10/S5

serie di 5 scalpelli per martelli scalpellatori 1940E10



1940E10/S5	€ 45,00	1	019400050
------------	---------	---	-----------



Beta

1942A

seghetto alternativo

CE



Corse al minuto	10.000
Lunghezza della corsa	10 mm
Attacco aria	1/4" GAS BSP
Pressione di utilizzo	6,2 bar
Ø interno tubo aria	8 mm
Consumo aria medio	75 l/min
Peso	550 g

550 g € 269,00 1 019420000

1942LR

lame Bimetal
per seghetto alternativo 1942A



1942LR € 6,20 5 019420032

1944A

scrostatore ad aghi assiale

CE



Colpi al minuto	3.800
Corsa del pistone	33 mm
N. aghi	19
Ø aghi	3 mm
Attacco aria	1/4" GAS
Pressione di utilizzo	6,2 bar
Ø interno tubo aria	10 mm
Consumo aria medio	85 l/min
Peso	2,8 kg

2,8 kg € 303,00 1 019440011

1944N

scrostatore ad aghi

CE



Colpi al minuto	3800
Corsa del pistone	33 mm
N. aghi	19
Ø aghi	3 mm
Attacco aria	1/4" GAS
Pressione di utilizzo	6,2 bar
Ø interno tubo aria	10 mm
Consumo aria medio	85 l/min
Peso	2,7 kg

2,7 kg € 387,00 1 019440002

1944AR

aghi di ricambio
per scrostatore 1944N e 1944A



	Ø mm	n.	€		
1944AR 2	2	29	40,00	1	019440015
1944AR 3	3	19	31,00	1	019440005

1944PA

piastre porta aghi per 1944N e 1944A



	Ø mm	N.	€		
1944PA 2	2	29	44,00	1	019440016
1944PA 3	3	19	33,00	1	019440006



1945S

graffettatrice

• Utilizza graffette tipo 80, sezione 0,95 x 0,65 mm (21 Gauge), lunghezza 4 - 16 mm, larghezza 12,8 mm

CE



Capacità caricatore	157 pz.
Attacco aria	1/4" GAS
Pressione utilizzo	4,2 - 7 bar
Ø interno tubo aria	8 mm
Consumo aria (7 bar)	0,34 l/ciclo
Peso	0,87 kg

0,9 kg € 165,00 1 019450000

1945S/G...

graffette tipo 80, sezione 0,95x0,65 mm (21 Gauge), larghezza 12,8 mm per 1945S

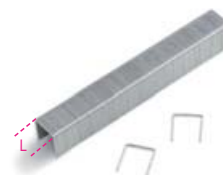

	L mm	€		
• 1945S/G4	4	15,20	1	019450004
1945S/G6	6	6,00	1	019450006
1945S/G8	8	6,50	1	019450008
1945S/G10	10	7,30	1	019450010
1945S/G12	12	8,10	1	019450012
1945S/G14	14	8,80	1	019450014
1945S/G16	16	9,60	1	019450016

I prezzi indicati sono relativi a 5.000 pezzi
• I prezzi indicati sono relativi a 10.000 pezzi

1945C

graffettatrice, groppinatrice combinata

• Utilizza graffette tipo 90, sezione 1,25 x 1,0 mm (18 Gauge), lunghezza 16 - 40 mm, larghezza 5,8 mm
• Utilizza groppini tipo B12, sezione 1,25 x 1,0 mm (18 Gauge), lunghezza 15 - 50 mm, testa da 1,9 mm

CE



Capacità caricatore	100 pz.
Attacco aria	1/4" GAS
Pressione utilizzo	5 - 8 bar
Ø interno tubo aria	8 mm
Consumo aria (7 bar)	1,12 l/ciclo
Peso	1,16 kg

1,16 kg € 217,00 1 019450200

1945C/G...

graffette tipo 90, sezione 1,25x1,0 mm (18 Gauge), larghezza 5,8 mm per 1945C

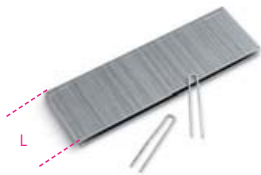

	L mm	€		
1945C/G16	16	11,60	1	019450216
1945C/G19	19	13,80	1	019450219
1945C/G22	22	15,10	1	019450222
1945C/G25	25	17,70	1	019450225
1945C/G28	28	18,70	1	019450228
1945C/G32	32	21,70	1	019450232
1945C/G35	35	23,50	1	019450235
1945C/G38	38	26,00	1	019450238
1945C/G40	40	28,00	1	019450240

I prezzi indicati sono relativi a 5.000 pezzi

1945C/GP...

groppini tipo B12, sezione 1,25x1,0 mm (18 Gauge), testa da 1,9 mm per 1945C



	L mm	€		
1945C/GP15	15	6,10	1	019450255
1945C/GP16	16	6,30	1	019450256
1945C/GP20	20	7,30	1	019450260
1945C/GP25	25	8,60	1	019450265
1945C/GP30	30	9,90	1	019450270
1945C/GP32	32	10,90	1	019450272
1945C/GP35	35	11,80	1	019450275
1945C/GP38	38	12,70	1	019450278
1945C/GP40	40	13,20	1	019450280
1945C/GP45	45	14,50	1	019450285
1945C/GP50	50	15,90	1	019450290

I prezzi indicati sono relativi a 5.000 pezzi

1945P

spillatrice

• Utilizza spilli tipo B6, Ø 0,64 mm (23 Gauge), lunghezza 12 - 35 mm



Capacità caricatore 145 pz.
 Attacco aria 1/4" GAS
 Pressione utilizzo 4 - 7 bar
 Ø interno tubo aria 8 mm
 Consumo aria (7 bar) 0,27 l/ciclo
 Peso 0,87 kg

kg	€		
0,87	263,00	1	019450100

1945P/S...

spilli tipo B6, Ø 0,64 mm (23 Gauge) per 1945P

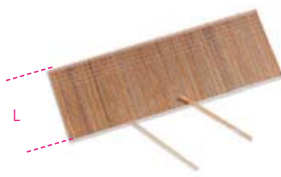

	L mm	€		
1945P/S12	12	7,10	1	019450112
1945P/S15	15	7,80	1	019450115
1945P/S18	18	8,50	1	019450118
1945P/S20	20	9,70	1	019450120
1945P/S21	21	9,90	1	019450121
1945P/S22	22	10,20	1	019450122
1945P/S25	25	10,90	1	019450125
1945P/S30	30	12,50	1	019450130
1945P/S35	35	14,30	1	019450135

I prezzi indicati sono relativi a 10.000 pezzi

1946T

rivettatrice

• fornita con ugelli intercambiabili per rivetti in acciaio, acciaio inox, alluminio e rame da 2,4 - 3,2 - 4,0 - 4,8 mm



Potenza di trazione 9.000 N
 Lunghezza della corsa 16 mm
 Capacità massima rivetti Ø acciaio inox 4,8 mm
 Attacco aria 1/4" GAS
 Pressione di utilizzo 6,2 bar
 Ø interno tubo aria 8 mm
 Consumo aria 2,0 l/ciclo
 Peso 1,7 kg

kg	€		
1,7	237,00	1	019460021

1946C4,8

rivettatrice

• Con aspirazione automatica
 • Fornita assemblata per rivetti in acciaio, acciaio inox, alluminio e rame, da 2,4 - 3,2 - 4,0 - 4,8 mm



Potenza di trazione 8.900 N
 Lunghezza della corsa 15 mm
 Capacità massima rivetti Ø acciaio inox 4,8 mm
 Attacco aria 1/4" GAS
 Pressione di utilizzo 6,2 bar
 Ø interno tubo aria 10 mm
 Consumo aria 2,6 l/ciclo
 Peso 1,5 kg

kg	€		
1,5	512,00	1	019460006

1946C7,8

rivettatrice

• Con aspirazione automatica
 • Fornita assemblata per rivetti in acciaio, acciaio inox, alluminio e rame, da 4,8 - 5,6 - 6,4 - 7,8 mm



Potenza di trazione 16.900 N
 Lunghezza della corsa 22,5 mm
 Capacità massima rivetti Ø acciaio inox 7,8 mm
 Attacco aria 1/4" GAS
 Pressione di utilizzo 6,2 bar
 Ø interno tubo aria 10 mm
 Consumo aria 4,9 l/ciclo
 Peso 1,8 kg

kg	€		
1,8	805,00	1	019460008

1946C/T...

testine per rivetti strutturali



Ø mm	€		
1946C/T4,8	4,8	31,00	1 019460016
1946C/T6,4	6,4	31,00	1 019460018

1946KF

rivettatrice per inserti filettati

- fornita assemblata per rivetti filettati in acciaio, acciaio inox, alluminio e rame, M4, M5, M6, M8



Potenza di trazione	14.235 N
Lunghezza della corsa	7 mm
Capacità massima rivetti	Ø acciaio inox M8
Attacco aria	1/4" GAS
Pressione di utilizzo	6,2 bar
Ø interno tubo aria	10 mm
Consumo aria	2,1 l/ciclo
Peso rivettatrice	2,1 kg
Peso kit	3,4 kg

kg	€	1	019460012
3,4	1.700,00		

1946KF/M...

perni di ricambio per 1946KF



1946KF/M4	€ 54,50	1	019460124
1946KF/M5	€ 54,50	1	019460125
1946KF/M6	€ 54,50	1	019460126
1946KF/M8	€ 54,50	1	019460128

1947

pistola per sigillanti

- Pistola pneumatica per silicone, collanti e sigillanti di media densità
- Supporta cartucce standard (215/218 x 50/51 mm) rigide e morbide



Dimensione del tubo	210x50 mm
Capacità della cartuccia	300 ml
Attacco aria	1/4" GAS
Pressione di utilizzo	4,8 bar
Ø interno tubo aria	10 mm
Consumo aria medio	120 l/min
Peso	1,1 kg

kg	€	1	019470001
1,1	57,50		

1947H

pistola per sigillanti

- pistola pneumatica per l'estrusione di siliconi e sigillanti in cartucce standard di plastica o alluminio
- supporta cartucce standard (215/218 x 50/51 mm) rigide e morbide
- riduttore di pressione integrato



Dimensione del tubo	210x50 mm
Capacità della cartuccia	300/310 ml
Attacco aria	1/4" GAS
Pressione di utilizzo	4 ÷ 8 bar
Ø interno tubo aria	2,5 mm
Consumo aria medio	120 l/min
Peso	750 g

kg	€	1	019470011
750	200,00		

1947G

pistola per ingrassaggio

- testa pressofusa in alluminio
- impugnatura ergonomica con figura a spigolo per accedere in spazi ristretti
- valvola in ottone per un'elevata durata
- funziona con cartucce da 400 g o grasso sfuso fino a 500 cc



dimensioni del tubo: 54 (interno) x 260 mm
 attacco aria: 1/4" GAS
 pressione d'utilizzo: 4÷10 bar
 peso: 1.9 kg

1947G	€ 141,00	1	019470051
-------	----------	---	-----------



1947M

pistola per sigillanti monocomponente

- Utilizzabile con cartucce in plastica da 310 ml
- Fornita con kit ugelli d'estrusione



Dimensione del tubo	210x50 mm
Capacità della cartuccia	310 ml
Attacco aria	1/4" GAS
Pressione di utilizzo	3 ÷ 5 bar
Ø ugelli	1,6 - 2,5 mm
Consumo aria medio	250 l/min
Peso	1,2 kg

kg	€	1	019470021
1,2	279,00		

1947M -...

ugelli di ricambio per 1947M



1947M-ST	€ 2,70	10	019470025
1947M-T	€ 1,50	10	019470026
1947M-P	€ 2,20	10	019470027

1948

penna per incisioni

- consente marcature su materiali quali l'acciaio, l'acciaio inossidabile, l'alluminio, il vetro, la pietra e la ceramica



Colpi al minuto	3.500 ÷ 3.800
Durezza massima	60 HRC
Attacco aria	1/4" GAS
Pressione di utilizzo	6,2 bar
Consumo aria medio	50 l/min
Peso	150 g

kg	€	1	019480001
150	264,00		

1948PR

punta in carburo di tungsteno di ricambio per 1948

- durezza massima: 60 HRC



1948PR € 99,50 1 019480005

1949U5

pistola di soffiaggio progressiva con 5 ugelli

- Corpo in materiale composito ad alta resistenza, antiurto
- 3 ugelli in acciaio 100/160/320 mm con puntale di protezione in gomma antigraffio
- 1 ugello "Turbo" in nylon rinforzato con fibre di vetro con puntale di sicurezza
- 1 ugello orientabile 100 mm in nylon rinforzato con fibre di vetro
- Dotato di sistema di fissaggio rapido



Ø 1/4" GAS BSPT

Inserto ottone filettato 1/4" GAS
Pressione di utilizzo 10 bar
Pressione massima di utilizzo 15 bar
Consumo aria medio 280 l/min
Temperatura di utilizzo -10°C ÷ 85°C
Peso 93 g

1949U5 € 31,50 1 019490030

1949U5/A

ugello in acciaio 100 mm con puntale di protezione in gomma antigraffio per 1949U5 - 1949P



1949U5/A € 6,30 1 019490131

1949U5/B

ugello in acciaio 160 mm con puntale di protezione in gomma antigraffio per 1949U5 - 1949P



1949U5/B € 6,40 1 019490132

1949U5/C

ugello in acciaio 320 mm con puntale di protezione in gomma antigraffio per 1949U5 - 1949P



1949U5/C € 8,20 1 019490133

1949U5/D

ugello orientabile 100 mm in nylon rinforzato con fibre di vetro per 1949U5 - 1949P



1949U5/D € 6,00 1 019490134

1949U5/E

ugello "Turbo" in nylon rinforzato con fibre di vetro con puntale di sicurezza per 1949U5 - 1949P



1949U5/E € 3,00 1 019490135

1949U5/F

ugello a ventaglio piatto, in nylon rinforzato con fibre di vetro, per 1949U5 e 1949P



1949U5/F € 3,80 1 019490136

1949U5/G

ugello OSHA, in nylon rinforzato con fibre di vetro, per 1949U5 e 1949P



1949U5/G € 2,90 1 019490137



1949BC

pistola di soffiaggio progressiva con ugello in gomma

- Corpo in materiale composito ad alta resistenza, antiurto
- Ugello in gomma antigraffio sostituibile
- Dotato di innesto



Inserto alluminio filettato 1/4" GAS
Pressione di utilizzo 6-8 bar
Pressione massima di utilizzo 15 bar
Consumo aria medio 87 l/min
Temperatura di utilizzo -20°C ÷ 70°C
Peso 120 g

1949BC € 15,30 1 019490022

1949BC/RU

5 ugelli in gomma per 1949BC



1949BC/RU € 19,00 1 019490122

1949P

mini pistola di soffiaggio progressiva

- Corpo in materiale composito ad alta resistenza, antiurto
- Sistema di fissaggio rapido degli ugelli
- Flusso dell'aria regolabile tramite rotazione della ghiera



Ø 1/4" GAS BSPT

Inserto ottone filettato 1/4" GAS
Pressione di utilizzo 6,2 bar
Pressione massima di utilizzo 8,3 bar
Consumo aria medio 280 l/min
Temperatura di utilizzo -10°C ÷ 85°C
Peso 70 g

1949P € 20,00 1 019490031

1949T

pistola di soffiaggio progressiva telescopica

- Corpo in materiale composito ad alta resistenza, antiurto
- Tubo telescopico in acciaio orientabile: 165 mm + 300 mm
- Dotato di innesto



Inserto in alluminio filettato	1/4" GAS
Pressione di utilizzo	6÷8 bar
Pressione massima di utilizzo	15 bar
Consumo aria medio	144 l/min
Temperatura di utilizzo	-20°C ÷ 70°C
Peso	190 g

g	€	1	019490040
190	24,70		

1949F

pistola di soffiaggio progressiva

- In composito di materiale plastico ad alta resistenza, antiurto, antigraffio e termicamente isolato
- La speciale valvola e la sensibilità della leva consentono la progressiva apertura del circuito, ottimizzando il flusso dell'aria



Inserto ottone filettato	1/4" GAS
Pressione di utilizzo	6-8 bar
Pressione massima di utilizzo	10 bar
Temperatura di utilizzo	-15°C ÷ 70°C
Peso	130 g

g	€	5	019490027
130	14,20		

Beta

1949G

pistola di soffiaggio progressiva con regolatore d'aria

- In composito di materiale plastico ad alta resistenza, antiurto, antigraffio e termicamente isolato
- La speciale valvola e la sensibilità della leva consentono la progressiva apertura del circuito, ottimizzando il flusso dell'aria



Inserto ottone filettato	1/4" GAS
Pressione di utilizzo	6-8 bar
Pressione massima di utilizzo	10 bar
Temperatura d'utilizzo	-15 °C ÷ 70 °C
Peso	140 g

g	€	5	019490035
140	14,50		

1949DGT

pistola digitale per gonfiaggio pneumatici

- Pressione di esercizio: 0÷14 bar (0÷200 psi)
- 4 unità di misura: psi/bar/kgcm2/kpa
- Display LCD retroilluminato
- Funzione reset
- Autospegnimento dopo 3 min.
- Pulsante di scarico pressione
- Risoluzione: 0,05 bar
- Corpo in abs, guscio protettivo in gomma sul manometro, impugnatura antiurto e antiscivolo
- Alimentazione: 2 batterie 1,5V tipo AAA
- Compatibile con l'innesto 1916I 1/4"



bar	psi	g	€	1	019490020
0-14	5÷60	500	141,00		

1949GPE

pistola per gonfiaggio pneumatici

- Pressione di esercizio: 0÷11 bar (10÷160 psi)
- Funzione di scarico pressione
- Funzione di solo misurazione della pressione
- Manometro rivestito in gomma antiurto
- Rotazione del tubo a 360°



bar	g	€	1	019490008
0÷11	640	110,00		

1949GPN

pistola per gonfiaggio pneumatici corpo in ABS

- manometro certificato CE con scala 0,7÷12 bar (ripartizione in 1/10 bar)
- 2 pulsanti servoassistiti consentono il gonfiaggio (+) e lo sgonfiaggio (-) del pneumatico con precisione e rapidità
- fornita con certificato di taratura
- fornita con guscio di protezione antiurto e occhiello per aggancio
- fornita con raccordo filettato 1/4" GAS
- attacco aria girevole per tubo in gomma Ø7 mm



bar	g	€	1	019490011
0,7÷12	810	224,50		

1949M

misuratore di pressione per pneumatici



bar	psi	g	€	1	019490400
0÷4	5÷60	280	63,50		

Beta

Beta

Quality Tools

Beta

1951

pistola di lavaggio

• indicata per la pulizia di tappezzeria auto, moquette, sedili e bagagliai



Capacità serbatoio 1 L
 Attacco aria 1/4" GAS
 Pressione di utilizzo 6,2 bar
 Ø interno tubo aria 8 mm
 Consumo aria medio 110 l/min
 Peso 650 g

650 g € 124,00 1 019510051

1951A

pistola di lavaggio con aspirazione

• Indicata per la pulizia di tappezzeria auto, moquette, sedili e bagagliai
 • Da utilizzare con detergenti specifici
 • Serbatoio da 1L
 • Dotato di rubinetto per la regolazione dell'uscita del liquido contenuto nel serbatoio
 • Completa di tubo corrugato da 1,8 m
 • Compatibile con aspiratore codice 1873-1874



Capacità serbatoio 1 l
 Attacco aria 1/4" GAS
 Pressione di utilizzo 6,2 bar
 Ø interno tubo aria 8 mm
 Consumo aria medio 120 l/min
 Peso 800 g

800 g € 202,00 1 019510101

1952

aerografo per verniciatura professionale

• Corpo in alluminio pressofuso con trattamento protettivo in nickel chimico nero
 • Tazza in nylon con dispositivo salvagoccia, filetto 3/8M BSP
 • Filettatura sul corpo 1/4" BSP Gas cilindrica
 • Regolatore di pressione e di portata aria
 • Regolatore del getto da tondo a ventaglio
 • Regolatore della quantità di vernice
 • Fornito con chiave di servizio per la manutenzione

CE



Ø mm	€	1	019520012
1,2	133,00	1	019520012
1,5	133,00	1	019520015
1,8	133,00	1	019520018
2,0	133,00	1	019520020

1901BM/8

avvolgitubo automatico
 corpo in materiale plastico antiurto
 per aria compressa o acqua fredda
 • Pressione di utilizzo massima 12 bar

CE

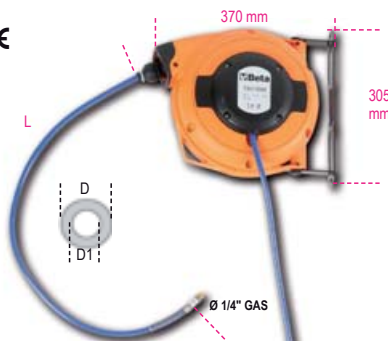

D1xD mm	L m	Ø GAS BSP	€	1	019010111
8x12	9+1	1/4"	229,00	1	019010111

1901T/10

avvolgitubo automatico
 corpo in materiale plastico antiurto
 per aria compressa o acqua fredda
 • Pressione di utilizzo massima 15 bar

CE

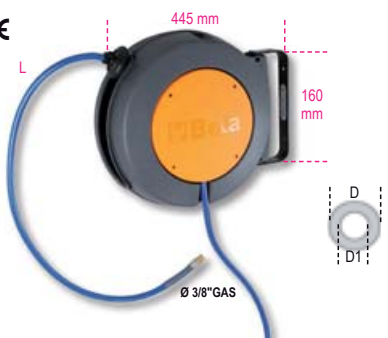

D1xD mm	L m	Ø GAS BSP	€	1	019010210
10x14	15+1	3/8"	270,00	1	019010210

1910

avvolgitubo automatico
 corpo in alluminio
 per aria compressa o acqua fredda
 • Pressione di utilizzo massima 15 bar

CE



D1xD mm	L m	A mm	B mm	Ø GAS mm
8x12	9+1	375	130	1/4"

1910/8 € 355,00 1 019100008

D1xD mm	L m	A mm	B mm	Ø GAS mm
10x14	15+1	490	160	3/8"

1910/10 € 530,00 1 019100010

1914

spirali in poliuretano 98 Shore estensibili

• Pressione di utilizzo massima 12 bar



L m	D1xD mm	Ø GAS BSP	€	1	019140054
4	5x8	1/4"	20,70	1	019140054
6	5x8	1/4"	24,20	1	019140056
10	5x8	1/4"	31,50	1	019140060

1915B

spirali in poliuretano 95 Shore estensibili fino a 9 m

• Pressione di utilizzo massima 10 bar

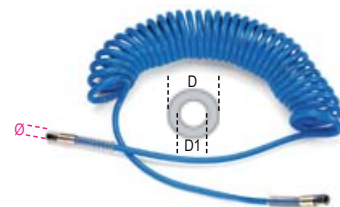

D1xD mm	Ø GAS BSP	€	1	019150011
6,5x10	1/4"	36,00	1	019150011
8x12	1/4"	43,00	1	019150012
11x16	3/8"	69,50	1	019150013

Beta

Quality Tools

1915C

spirali in poliuretano 95 Shore
estensibili fino a 12 m

• Pressione di utilizzo massima 10 bar

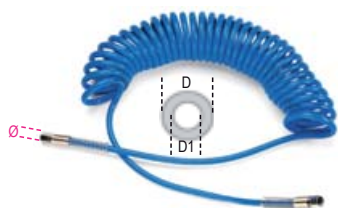

D1xD	Ø GAS	€		
mm	BSP			
6,5x10	1/4"	43,00	1	019150014
8x12	1/4"	52,50	1	019150015
11x16	3/8"	85,50	1	019150016

1915C/L

spirali in poliuretano 95 Shore
estensibili fino a 15 m

• Pressione di utilizzo massima 10 bar

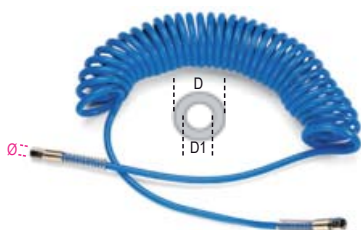

D1xD	Ø GAS	€		
mm	BSP			
8x12	1/4"	68,00	1	019150115
11x16	3/8"	114,00	1	019150116

1915D

tubo in poliuretano retinato 95 Shore
lunghezza 9 m

• Pressione di utilizzo massima 15 bar



D1xD	Ø GAS	€		
mm	BSP			
8x12	1/4"	43,00	1	019150017
11x16	3/8"	68,00	1	019150018

1915E

tubo in poliuretano retinato 95 Shore
lunghezza 12 m

• Pressione di utilizzo massima 15 bar



D1xD	Ø GAS	€		
mm	BSP			
8x12	1/4"	57,00	1	019150019
11x16	3/8"	85,00	1	019150020

1915E/XL

bobine in poliuretano retinato 95 Shore
lunghezza 50 m

• Pressione di utilizzo massima 15 bar



D1xD	Ø GAS	€		
mm	BSP			
8x12	1/4"	195,00	1	019150519
11x16	3/8"	326,00	1	019150520

1916I

innesti rapidi profilo Italia
filettati maschio, GAS cilindrici BSP



Ø GAS	€		
BSP			
1/4"	2,50	5	019160001
3/8"	2,85	5	019160002

1916G

innesti rapidi profilo Europa
filettati maschio, GAS conici BSPT



Ø GAS	€		
BSPT			
1/4"	2,50	5	019160005
3/8"	3,30	5	019160010
1/2"	3,70	5	019160012

1916GF

innesti rapidi profilo Italia
filettati femmina, GAS cilindrici BSP



Ø GAS	€		
BSP			
1/4"	2,50	5	019160055
3/8"	2,85	5	019160060

1916GFE

innesti rapidi profilo Europa
filettati femmina, GAS conici BSPT



Ø GAS	€		
BSPT			
1/4"	2,50	5	019160075
3/8"	3,30	5	019160082
1/2"	3,70	5	019160084

1916JM

innesti rapidi profilo asiatico
filettati maschio, GAS conici BSPT



Ø GAS	€		
BSPT			
1/4"	3,50	1	019160406
3/8"	3,70	1	019160410

1916JF

innesti rapidi profilo asiatico
filettati femmina, GAS cilindrici BSP



Ø GAS	€		
BSPT			
1/4"	3,50	1	019160456
3/8"	3,70	1	019160460

1916P

innesti rapidi profilo Italia
con mascherina portagomma



D1xD	€		
mm			
6x14	3,30	5	019160256
8x17	3,55	5	019160258
10x19	4,70	5	019160260

1916S

innesti rapidi profilo Italia
con molla a spirale

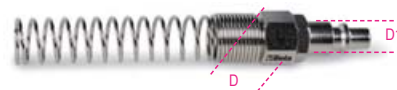

D1xD	€		
mm			
6x8	3,30	5	019160306
8x10	3,50	5	019160308
10x12	4,50	5	019160310

1917M

raccordi universali a sfera
con gomma antiurto
filettati maschio GAS cilindrici BSP

• accoppiabili agli innesti 1916I e 1916G



Ø GAS	€		
BSP			
1/4"	9,00	5	019170001
3/8"	9,00	5	019170003
1/2"	9,50	5	019170004

1917F

raccordi universali a sfera
con gomma antiurto
filettati femmina GAS cilindrici BSP

• accoppiabili agli innesti 1916I e 1916G



Ø GAS BSP	€		
1/4"	9,30	5	019170005
3/8"	9,00	5	019170010
1/2"	9,80	5	019170014

1917JM

raccordi universali a sfera
per profilo asiatico
filettati maschio GAS cilindrici BSP



Ø GAS BSP	€		
1/4"	15,00	1	019170406
3/8"	15,00	1	019170410
1/2"	16,00	1	019170412

1917JF

raccordi a sfera per profilo asiatico
filettati femmina GAS cilindrici BSP



Ø GAS BSP	€		
1/4"	15,00	1	019170456
3/8"	15,00	1	019170460

1917RG

raccordo universale rotante

- In alluminio, filetto femmina, GAS cilindrico BSP filetto maschio, cilindrico BSP
- Accoppiabile a tutti gli innesti con profilo Italia ed Europa
- Rotazione libera anche in assenza d'aria connessa



Ø GAS BSP	€		
1/4"	19,50	1	019170252

1917SP

raccordi universali a sfera
con mascherina portagomma



D1xD mm	€		
6x14	9,50	5	019170206
8x17	9,90	5	019170208
10x19	11,50	5	019170210

1917ST

raccordi universali a sfera
con molla a spirale



D1xD mm	€		
6x8	8,90	5	019170306
8x10	9,10	5	019170308
10x12	10,20	5	019170310

1918

attacco a resca filettato maschio



D1 mm	Ø GAS BSP	€		
6	1/8"	2,00	3	019180106
8	1/8"	2,00	3	019180108
6	1/4"	2,20	3	019180116
8	1/4"	2,30	3	019180118
10	1/4"	2,30	3	019180120
10	3/8"	2,60	3	019180130
12	3/8"	2,70	3	019180132
10	1/2"	3,60	3	019180140
12	1/2"	3,70	3	019180142

1918N

nippli di collegamento
con filetto conico BSPT



Ø mm	Ø1 mm	€		
1/4"	1/4"	2,30	5	019180300
3/8"	3/8"	2,70	5	019180310
1/2"	1/2"	3,70	5	019180320

1918R

nippli di riduzione
con filetto conico BSPT



Ø mm	Ø1 mm	€		
1/4"	3/8"	2,60	5	019180200
3/8"	1/2"	3,60	5	019180210

1919FE1/4

filtro regolatore lubrificatore



Attacchi aria entrata/uscita 1/4" GAS BSPT
 Attacco manometro 1/8" GAS BSPT
 Portata massima 750 l/min
 Pressione massima 9,5 bar
 Pressione di utilizzo 0,5 - 8,5 bar
 Temperatura di utilizzo 5 - 60 °C
 Capacità filtrante 5 micron
 Capacità tazze 15 cc aria / 25 cc olio
 Peso 700 g

g	€		
700	90,00	1	019190200

1919RB-FE1/4

coppia bicchieri di ricambio
per 1919FE1/4



€		
19,50	1	019190210

1919RF-FE1/4

ricambio elemento filtrante
per 1919FE1/4



€		
5,30	1	019190230

1919RM-FE1/4

manometro di ricambio
per 1919FE1/4



€		
11,50	1	019190220

1919F1/4

filtro regolatore lubrificatore



Attacchi aria entrata/uscita 1/4" GAS BSPT
 Portata massima 1000 l/min
 Pressione massima 9,5 bar
 Pressione di utilizzo 0,5 - 8,5 bar
 Temperatura di utilizzo 5 - 60 °C
 Capacità filtrante 5 micron
 Capacità tazze 60 cc aria / 90 cc olio
 Peso 1,3 kg

kg 1,3 € 142,00 1 019190250

1919F3/8

filtro regolatore lubrificatore



Attacchi aria entrata/uscita 3/8" GAS BSPT
 Portata massima 1350 l/min
 Pressione massima 9,5 bar
 Pressione di utilizzo 0,5 - 8,5 bar
 Temperatura di utilizzo 5 - 60 °C
 Capacità filtrante 5 micron
 Capacità tazze 60 cc aria / 90 cc olio
 Peso 1,3 kg

kg 1,3 € 142,00 1 019190350

1919F1/2

filtro regolatore lubrificatore



Attacchi aria entrata/uscita 1/2" GAS BSPT
 Portata massima 2500 l/min
 Pressione massima 9,5 bar
 Pressione di utilizzo 0,5 - 8,5 bar
 Temperatura di utilizzo 5 - 60 °C
 Capacità filtrante 5 micron
 Capacità tazze 60 cc aria / 90 cc olio
 Peso 1,3 kg

kg 1,3 € 142,00 1 019190450

1919RB-F

coppia bicchieri
 per filtri 1919F - 1/4", 3/8" e 1/2"



1919RB-F € 25,00 1 019190510

1919RF-F

ricambio elemento filtrante
 per filtri 1919F - 1/4", 3/8" e 1/2"



1919RF-F € 9,80 1 019190530

1919RM-F

manometro di ricambio
 per filtri 1919F - 1/4", 3/8" e 1/2"



1919RM-F € 14,80 1 019190520

1919ML

mini lubrificatori di linea



Ø	L	Ø	€	1	019190030
1/4"	63	36	18,30	1	019190030
3/8"	63	36	19,80	1	019190032

1919SC

mini separatore di condensa



Ø	L	Ø	€	1	019190035
1/4"	80	40	23,50	1	019190035

1919L

olio lubrificatore ISO 32

Densità a 20°C 875 kg/m³
 Viscosità a 40°C 32 cSt
 Infiammabilità COC 210°C



cc 500 € 16,00 5 019190050

Beta

Beta



CONTENITORI E ASSORTIMENTI

			VALIGIE E TROLLEY						BORSE E CESTELLI PORTAUTENSILI											TROLLEY PORTAUTENSILI										
Applicazione	N° pezzi		2009N/BV	2028/VV	2029/VV	2032TV	2033P/VV	2036TV	C4	C5	C6T	C7	C8	C10	C9	C10S	C11	CP15L	CP17L	C12	C14	CP15	C18	C19	C19L	C20	C20L	C41H	C42H	
5915VU/0	Interventi universali	35							430																					
5915VU/1	Interventi universali	45												431	431	431						431	431							
5915VU/2	Interventi universali	49										432											432			432	432			
5915VU/3	Interventi universali	74										433		433	433	433									433	433	433			
5915VU/4	Interventi universali	80																								434	434			
5915VU/5	Interventi universali	111																			435						435	435		
5915VU/AS	Interventi universali	68												436												436	436			
5980EL/A	Elettronica	57	450			450	450																							
5980EL/B	Elettronica	98		451		451	451																							
5980ET/A	Elettrotecnica	70	446			446															446									
5980ET/B	Elettrotecnica	64		447		447	447														447									
5980ID	Idraulica	35	452																											
5980MQ	Elettrotecnica	46		448																										
5980U/BIKE	Riparazione moto e bici	90															441										441			
5914VU/M	Interventi universali	109																				428								
5940SBK	Riparazione moto e bici	125																										465	465	
5941VU-M	Interventi universali	64																										466		

2001/B26

busta in tessuto con assortimento di 26 utensili



2001/B26 € 190,00 1 020010215

55 6x7 - 8x9 - 10x11 - 12x13 - 14x15 - 16x17 mm

96N/SC9 1,5 - 2 - 2,5 - 3 - 4 - 5 - 6 - 8 - 10 mm

1044F 250 mm

1128BMX 145 mm

1150 180 mm

1201E 3x75 - 4x100 - 5,5x150 mm

1202E PH1x80 - PH2x100 mm

1370 300 g

1692 2 m

1770A 9 mm

2001/BV € 41,00 1 020010051

2005PA/D

porta attrezzi vuoto in Nylon, con cintura



2005PA/D € 51,50 1 020050000

2005PA/S

porta attrezzi vuoto in Nylon, con cintura



2005PA/S € 26,00 1 020050020

2009N/BV

borsa per manutentori in cuoio



530x190x210 mm € 217,00 1 020090200

2009ID

borsa con assortimento di 35 utensili per idraulica



2009ID € 706,00 1 020091013
(2009N/BV+5980ID)

2028/WV

valigia portautensili in polipropilene

- 2 pannelli portautensili
- Fondo interno con divisori removibili
- Doppia chiusura con combinazione



470x410x185 mm € 196,00 1 020280010

2028E

valigia con assortimento di utensili per elettronica ed elettrotecnica



2028EL/A € 949,00 1 020281014
(2028/VV+5980EL/A)
2028ET/A € 961,00 1 020281018
(2028/VV+5980ET/A)

2029/WV

valigia portautensili in polipropilene ad alto spessore, profilata in alluminio.

- 2 pannelli portautensili
- Fondo con divisori removibili e regolabili
- Fornita di tracolla
- 2 serrature con chiave



490x380x230 mm € 279,00 1 020290000

2029E

valigie con assortimenti di utensili per elettronica ed elettrotecnica



2029 BG MQ € 1.700,00 1 020291257
(2029/VV+5980MQ)
2029ET/B € 1.325,00 1 020291021
(2029/VV+5980ET/B)
2029EL/B € 1.340,00 1 020291017
(2029/VV+5980EL/B)

2029/RT

tracolla universale per borse e valigie



2029/RT € 18,50 1 020290000

Beta
Quality Tools



2032/TV

trolley portautensili in materiale plastico

2 pannelli portautensili
Tasca portautensili interna
Fondo interno con divisori removibili



mm
430x370x200 € 360,00 1 020320110

2032/TE

trolley con assortimento di utensili per elettronica ed elettrotecnica



€ 1.125,00 1 020321328
2032TET/A (2032/TV+5980ET/A)
€ 1.113,00 1 020321314
2032TEL/A (2032/TV+5980EL/A)

2033 P/VV

valigia portautensili, in alluminio con fianchi in ABS

2 pannelli portautensili
Fondo interno con divisori removibili
2 serrature con chiave



mm
500x380x200 € 405,00 1 020330300

2033P

valigie con assortimenti di utensili per elettronica ed elettrotecnica



€ 1.450,00 1 020331227
2033PET/B (2033P/VV+5980ET/B)
€ 1.158,00 1 020331214
2033PEL/A (2033P/VV+5980EL/A)
€ 1.465,00 1 020331215
2033PEL/B (2033P/VV+5980EL/B)

2036/TV

trolley portautensili in polipropilene ad alto spessore, profilato in alluminio

2 pannelli portautensili
Manico telescopico
Ruote con cuscinetti a sfera
Fondo interno con divisori removibili



mm
490x380x260 € 421,00 1 020360000

2036E

trolley con assortimenti di utensili per elettronica ed elettrotecnica



€ 1.470,00 1 020361223
2036TET/B (2036/TV+5980ET/B)
€ 1.480,00 1 020361218
2036EL/B (2036/TV+5980EL/B)

2037/TV

trolley portautensili in polipropilene ad alto spessore con 4 ruote pivotanti

Estremamente resistente agli urti. Indicato per il trasporto di utensili in aereo.
2 pannelli portautensili rimovibili.
Tasca portadocumenti integrata.
4 ruote pivotanti rimovibili che consentono la movimentazione orizzontale del trolley.
2 vaschette portaminuterie incluse
2 serrature omologate TSA con chiave
Maniglia ergonomica rivestita in gomma



mm
420x325x275 mm € 520,00 1 020370000

2038/TV

trolley portautensili in polipropilene ad alto spessore

- Estremamente resistente agli urti.
- Profilo di tenuta in alluminio
- 2 serrature omologate TSA con chiave
- 2 pannelli portautensili rimovibili.
- Maniglia telescopica e grandi ruote con cuscinetti a sfera
- 2 maniglie (1 laterale) ergonomiche rivestite in gomma
- Fondo capiente
- Tasca porta documenti
- 3 cassettoni porta minuteria



mm
430x500x340 € 689,00 1 020380000



2041UC

valigia Utility Case con assortimento di 33 utensili



2041UC € 287,00 1 020410215

- 55 6x7 - 8x9 - 10x11 - 12x13 - 14x15 - 16x17 mm
- 96/SC9 1,5 - 2 - 2,5 - 3 - 4 - 5 - 6 - 8 - 10 mm
- 111 200 mm
- 1048V 250 mm
- 1128BMX 145 mm
- 1150 180 mm
- 1201E 2,5x50 - 3x75 - 4x100 - 5,5x100 - 6,5x150 mm
- 1202E PH0x60 - PH1x80 - PH2x100 mm
- 1370 300 g
- 1692 3m
- 1771 170 mm
- 1833S 70 Lumen / 140 mm
- 1639NS-N 25m
- 1696 200 mm

535x282x87 mm - 4,5 Kg

2051N

valigia in polipropilene antiurto con assortimento di 55 utensili per nautica



2051N € 680,00 1 020510215

- 42NEW 7 - 8 - 10 - 12 - 13 - 14 - 17 - 19 mm
- 55AS 3/8x7/16 - 1/2x9/16 - 5/8x11/16"
- 956C □ 1/2 - 16 - 20,8 mm
- 1048 250 mm
- 1084BM 160 mm
- 1128BMX 145 mm
- 1150BM 180 mm
- 1166BM 160 mm
- 1201E ● 3x75 - 4x100 - 5,5x150 - 6,5x150 mm
- 1202E ● PH1x80 - PH2x100 mm
- 1390 ∅ 35 mm
- 1490/2 ∅ max 240 mm
- 96/SC9 ○ 1,5÷10 mm
- 1737 145 mm
- 1778X
- 1748N 3,6 x 140 mm
- 1639NS-N 25m
- 111 200 mm
- 920A ○ 10 - 12 - 13 - 14 - 17 - 19 mm
- 920AS ○ 7/16 - 1/2 - 9/16 - 11/16 - 7/8"
- 920/22 255 mm - □ 1/2 - ■ 1/2
- 920/25 □ 1/2 - ■ 1/2
- 920/42 ■ 1/2
- 920/55 ■ 1/2

585x393x92 mm - 9 kg

2055HB

valigia Home Bag con assortimento di 24 utensili



2055HB € 172,00 1 020550215

- 55 6x7 - 8x9 - 10x11 - 12x13 mm
- 96N/SC9 1,5 - 2 - 2,5 - 3 - 4 - 5 - 6 - 8 - 10 mm
- 1128BMX 145 mm
- 1150 180 mm
- 1048V 250 mm
- 1201E 3x75 - 4x100 - 5,5x100 mm
- 1202E PH0x60 - PH1x80 - PH2x100 mm
- 1370 300 g
- 1692 3m

373x275x70 mm - 3 Kg

2060/WV

valigia portautensili per nautica a tenuta stagna

Galleggiante e impermeabile
In resina ad alto spessore
Dotata di valvola di rilascio a pressione manuale
2 pannelli portautensili
Fondo interno con divisori removibili e 2 vaschette portaminuteria incluse



IP67



490x410x210 mm € 376,00 1 020600101

2080/V6

valigia organizer con 6 vaschette asportabili e divisori regolabili



2080/V6 385x320x60 mm € 31,00 1 020800060

2080/V6-U

vaschetta asportabile per valigia organizer 2080/V6



2080/V6-U € 2,25 1 020800066

90x60x50 mm

2080/D10

set 10 divisori regolabili per valigia organizer 2080/V6



2080/D10 € 6,00 1 020800070



2080/V12

valigia organizer con 12 vaschette asportabili



2080/V12 300x145x330 mm € 47,00 1 020800000

2080/V12-...

vaschetta asportabile per valigia organizer 2080/V12



2080/V12-S	€ 2,90	3	020800013
95x75x65 mm			
2080/V12-M	€ 4,30	2	020800015
145x75x65 mm			
2080/V12-L	€ 7,40	1	020800020
295x75x65 mm			

C4 - 2104

secchiello portautensili in tessuto tecnico, vuoto

Pannello portautensili interno estraibile
Tasche ed elastici portautensili sia esterni che interni
Base rigida impermeabile con piedini in gomma
Fornito di tracolla



C4	€ 88,00	1	021040000
2104VU/0	€ 425,00	1	021041122
(C4+5915VU/0)			

360x330x260 mm - 2,5 kg

C5S

zaino portautensili in poliester resistente

- Doppia maniglia sulla sommità centrale dello zaino per una presa sicura e bilanciata
- Due ampie tasche frontali
- Due capienti tasche interne e 2 fasce aggiuntive con velcro
- Pratica busta avvolgibile interna, composta da 4 pannelli portautensili
- Spallacci imbottiti rinforzati e regolabili
- Carico massimo 15 Kg



C5S	€ 45,00	1	021050100
-----	---------	---	-----------

370x300x100 mm - 0,9 Kg

C5 - 2105

zaino portautensili in tessuto tecnico

- Pannello portautensili interno removibile
- Sei tasche esterne
- Due capienti tasche interne
- Base in materiale plastico resistente all'acqua
- Doppio laccetto di sicurezza per fissare lo zaino sulle spalle
- Schienale ergonomico imbottito



C5	€ 125,00	1	021050000
2105VU/0	€ 462,00	1	021051122
(C5+5915VU/0)			

500x400x180 mm - 2,5 Kg

Beta

C6T - 2106

zaino portautensili in tessuto tecnico, con ruote

- Manico telescopico di trasporto
- Ruote integrate nella struttura con copertura anti-polvere per l'impiego come zaino
- Due pannelli portautensili removibili
- Cinque tasche esterne
- Capiente tasca per pc interna
- Base in materiale resistente all'acqua



C6T	€ 178,00	1	021060010
2106T/VU0 (C6T+5915VU/0)	€ 515,00	1	021061123

480x370x220 mm - 4,5 kg

C7 - 2107

borsa portautensili in tessuto tecnico

- 2 pannelli interni portautensili removibili
- 2 tasche esterne frontali
- Fondo interno in materiale plastico con divisori removibili



C7	€ 185,00	1	021070000
2107VU/2 (C7+5915VU/2)	€ 539,00	1	021071112
2107VU/3 (C7+5915VU/3)	€ 948,00	1	021071114

440x370x170 mm - 3,5 kg

C8 - 2108

trolley portautensili in tessuto tecnico

- Manico telescopico di trasporto
- 2 pannelli interni portautensili removibili
- Tasca porta PC interna
- 2 tasche esterne frontali
- Predisposizione per l'alloggiamento del cestello C10S



C8	€ 209,00	1	021080000
2108 VU/1 (C8+5915VU/1)	€ 622,00	1	021081022

470x370x280 mm - 4 kg

C9 - 2109

borsa portautensili in tessuto tecnico

- Base rigida
- Tasche interne ed esterne per l'inserimento di utensili
- Tasca esterna con chiusura a zip per maggior sicurezza
- Tasca chiudibile con strappo per oggetti personali
- Doppio fondo
- Doppio laccio per livelli
- Tracolla per facilitare il trasporto



C9	€ 101,50	1	021090000
2109VU/1 (C9+5915VU/1)	€ 514,00	1	021091022
2109VU/3 (C9+5915VU/3)	€ 865,00	1	021091024

550x280x320 mm - 2,6 kg

C9/RT

tracolla per C4,C7,C9,C10,C10S,C11 e C12



C9/RT	€ 13,00	1	021090900
-------	---------	---	-----------

C10 - 2110

cestello portautensili in tessuto tecnico

- Struttura rigida
- Doppio fondo. Il fondo si può rimuovere per aumentare la capienza della borsa
- Manico inclinabile per facilitare l'accesso agli utensili
- Elastici portautensili e tasche sia interne che esterne
- Fodero di copertura
- Vaschetta portaminuterie inclusa nel doppio fondo



C10	€ 126,00	1	021100000
2110VU/1 (C10+5915VU/1)	€ 539,00	1	021101031
2110VU/3 (C10+5915VU/3)	€ 889,00	1	021101034
2110VU/AS (C10+5915VU/AS)	€ 962,00	1	021101036

520x220x250 mm - 3,3 kg

C10S - 2110S

cestello portautensili in tessuto tecnico

- Struttura rigida
- Manico inclinabile per facilitare l'accesso agli utensili
- Elastici portautensili e tasche sia interne che esterne
- Fodero di copertura
- Vaschetta portaminuterie inclusa nel doppio fondo



C10S	€ 99,00	1	021100001
2110SVU/1 (C10S+5915VU/1)	€ 512,00	1	021101041
2110SVU/3 (C10S+5915VU/3)	€ 862,00	1	021101044

420x220x250 mm - 2,3 kg





C11 - 2111

cestello portautensili in tessuto tecnico

- Base rigida in materiale plastico resistente all'acqua
- Elastici e tasche portautensili sia interne che esterne
- Buste portadocumenti integrate nel doppiofondo del coperchio



	€		
C11	74,00	1	021110000
2111VU/1 (C11+5915VU/1)	487,00	1	021111031
2111VU/3 (C11+5915VU/3)	837,00	1	021111034

≡ 400x240x220 mm - 2 kg

C12 - 2112

borsa portautensili in tessuto tecnico

- Pannello interno portautensili estraibile
- Elastici portautensili e capienti tasche sia interne che esterne
- La borsa si apre anteriormente per facilitare l'accesso agli utensili sul luogo di lavoro
- Base rigida impermeabile con piedini in gomma



	€		
C12	161,00	1	021120000
2112ET/A (C12+5980ET/A)	926,00	1	021121028
2112ET/B (C12+5980ET/B)	1.210,00	1	021121029
2112VU/5 (C12+5915VU/5)	1.129,00	1	021121056

≡ 500x370x270 mm - 5 kg

C13

baule portautensili con ruote,
in polipropilene ad alta resistenza

- Idoneo per uso esterno
- Resistente agli urti e agli agenti chimici
- Predisposizione per chiusura con lucchetto



	€		
C13	262,00	1	021130000

≡ 870x410x350 mm - 7,2 kg

C14

trolley portautensili in polipropilene con 4 cassetti

- Struttura in polipropilene a iniezione che garantisce elevata resistenza agli urti.
- La parte anteriore, protetta dal coperchio frontale, ospita 4 cassetti 470x255 mm estraibili:
 - 1 cassetto altezza 30 mm
 - 2 cassette altezza 60 mm
 - 1 cassetto altezza 90 mm
- Serratura centralizzata frontale consente di chiudere contemporaneamente i due coperchi, quello superiore e quello frontale.
- Due maniglie laterali
- 4 robuste ruote posteriori
- Vassoio superiore removibile
- Pannello portautensili integrato nel coperchio
- 3 vaschette porta minuteria incluse
- Targhetta identificativa portanome
- Predisposizione per la chiusura con lucchetto TSA



	€		
C14	670,00	1	021140000
2114VU/M (C14+5914VU/M)	1.580,00	1	021141011

≡ 580x380x455 mm - 10 kg

CP15 - 2115

cestello in materiale plastico con contenitore e
vaschette portaminuterie asportabili

- 1 vaschetta portaminuterie integrata nel coperchio
- 2 vaschette portaminuterie asportabili con divisori regolabili
- 1 contenitore interno con divisori regolabili



	€		
CP15	38,00	1	021150201
2115PVU/1 (CP15+5915VU/1)	451,00	1	021151232
2115PVU/2 (CP15+5915VU/2)	392,00	1	021151234

≡ 445x240x250 mm - 2 kg

CP15L - 2115

cestello modello lungo in materiale plastico
con contenitore e vaschette portaminuterie

- 3 vaschette portaminuterie integrate nel coperchio con divisori regolabili
- 1 contenitore interno con divisori regolabili



	€		
CP15L	51,00	1	021150202
2115PL-VU/1 (CP15L+5915VU/1)	464,00	1	021151242
2115PL-VU/3 (CP15L+5915VU/3)	814,00	1	021151245

558x277x270 mm - 2,5 kg





2115P L-MQ32

assortimento di 32 utensili isolati per auto ibride, in cestello plastico con termoformato morbido



2115PL-MQ32 € 984,00 1 021150332

- 920MQ/55A
- 89MQ 10-12 mm
- 850MQ 1/4"
- 860TX/A10 T7-T8-T9-T10-T15-T20-T25-T27-T30-T40
- 920MQ/A 8-10-12-13-14-17-19 mm
- 920MQ/21 125mm
- 920MQ/22 250mm
- 1048MQ250 250mm
- 1150MQ 180mm
- 1164MQ160 160mm
- 1272MQ 4.5X80-6X100mm
- 1274MQ 3X100-4X100-5.5X125
- 1995MQ/G2 G2
- CP15L

C16 - 2116

cestello in materiale plastico con vano portaoggetti interno



C16 € 84,00 1 021160000
 2116VU/1 € 497,00 1 021161102 (C16+5915VU/1)
 2116VU/3 € 847,00 1 021161105 (C16+5915VU/3)

500x260x260 mm - 2,5 kg

CP17 - CP17L - 2117

cestello in acciaio inox e materiale plastico con contenitore asportabile



CP17
500x200x220 mm



CP17L
575x245x265 mm

	€		
CP17	70,50	1	021170500
2117P-VU/1 (CP17+5915VU/1)	483,00	1	021171042
2117P-VU/3 (CP17+5915VU/3)	834,00	1	021171045
CP17L	101,00	1	021170502
2117L-VU/1 (CP17L+5915VU/1)	514,00	1	021171142
2117PL-VU/3 (CP17L+5915VU/3)	864,00	1	021171145

C18 - 2118

cestello semplice in lamiera



C18 € 33,50 1 021180001
 2118VU/1 € 446,00 1 021181032 (C18+5915VU/1)

450x200x100 mm - 3 kg

C19 - 2119 - C19L - 2119L

cestello estendibile a tre scomparti in lamiera



C19
450x200x160 mm



C19L
550x200x160 mm

	€		
C19	44,00	1	021190001
2119VU/3 (C19+5915VU/3)	807,00	1	021191025
C19L	56,50	1	021190002
2119L-VU/3 (C19L+5915VU/3)	820,00	1	021191125

C20 - C20L - 2120

cestello estendibile a cinque scomparti in lamiera



C20
450x200x210 mm



C20L
550x200x210 mm

	€		
C20	62,00	1	021200001
2120VU/2 (C20+5915VU/2)	416,00	1	021201061
2120VU/3 (C20+5915VU/3)	825,00	1	021201063
2120VU/4 (C20+5915VU/4)	1.053,00	1	021201064
2120VU/AS (C20+5915VU/AS)	898,00	1	021201068
C20L	67,50	1	021200002
2120L-VU/2 (C20L+5915VU/2)	422,00	1	021201161
2120L-VU/3 (C20L+5915VU/3)	831,00	1	021201163
2120L-VU/4 (C20L+5915VU/4)	1.059,00	1	021201164
2120L-VU/AS (C20L+5915VU/AS)	904,00	1	021201168



C20TSS

cestello estendibile a cinque scomparti
in acciaio inossidabile **AISI 304**



C20TSS € 241,00 1 021203001

≡ 450x200x210 mm - 4kg

C22B

baule portautensili in lamiera



C22B O
≡ 720x320x310 mm



C22BM O
≡ 850x360x350 mm



C22BL O
≡ 1010x410x400 mm

C22B-O € 175,00 1 022000150
C22BM-O € 201,50 1 022000160
C22BL-O € 269,00 1 022000170

C22B O: 13 kg
C22BM O: 20 kg
C22BL O: 26 kg

C22W

baule portautensili in lamiera, rivestito
internamente per una maggiore protezione
degli utensili



C22W O
≡ 690x300x360 mm



C22WL O
≡ 990x300x360 mm

C22W-O € 195,00 1 022000269
C22WL-O € 254,00 1 022000299

C22W O: 15 kg
C22WL O: 28 kg

C22P

baule portautensili da cantiere, in lamiera

maniglie incassate a scomparsa
pattini rialzati per il sollevamento con muletto
doppia chiusura anti-effrazione per lucchetto (non incluso)



C22PM O
≡ 915x540x430 mm



C22PL O
≡ 1220x720x615 mm

C22PM-O € 522,00 1 022000240
C22PL-O € 805,00 1 022000245

C22PM O: 39 kg
C22PL O: 67 kg



Beta



C99

Combo è il nuovo sistema modulare Beta composto da **3 diverse tipologie di robuste valigette** portautensili per riporre in maniera ordinata e in totale sicurezza la vostra attrezzatura da lavoro.

Le valigette possono essere facilmente unite tra di loro con un **semplice click**, grazie alle pratiche chiusure laterali a scatto.

Il nuovo sistema Beta Combo C99 è compatibile con lo standard L-BOXX di Sortimo®

C99V1

valigetta portautensili in ABS

Caratteristiche principali:

- Dimensioni esterne 445x358x152 mm
- Capacità di carico max. interna 25 Kg
- Predisposizione per la chiusura con lucchetto
- Peso 2,2 Kg

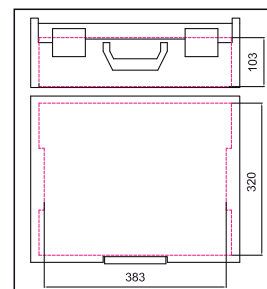

C99V1

€ 94,00 1 099000250

C99V2

valigetta portautensili in ABS

Caratteristiche principali:

- Dimensioni esterne 445x358x254 mm
- Capacità di carico max. interna 25 Kg
- Peso 2,8 Kg

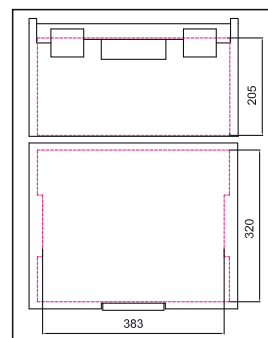

C99V2

€ 104,00 1 099000350

C99V3/2C

valigetta portautensili in ABS con 2 cassette portaminuteria trasportabili

Caratteristiche principali:

- Dimensioni esterne 445x358x322 mm
- Capacità di carico max. interna 25 Kg
- Fornita con 2 cassette portaminuteria C99C-V3 vuote
- Peso 5,6 Kg

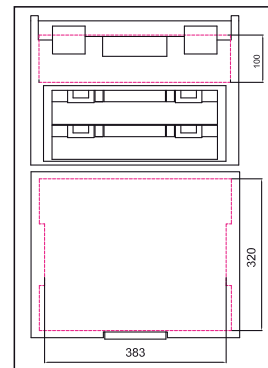

C99V3/2C

€ 200,00 1 099000450

C99C-V3

cassetta portautensili trasportabile

Coperchio trasparente per una rapida individuazione del contenuto

Maniglia integrata

Dimensioni esterne: 367x316x72 mm

Peso 0,9 Kg

Accessoriabile con:

- termoformato portaminuteria a 7 vani C99T-V3
- kit 17 vaschette portaminuteria C99P-V3

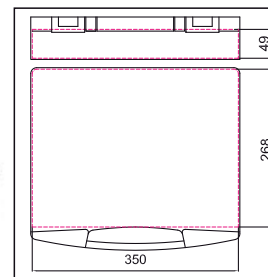

C99C-V3

€ 32,00 1 099000496

C99P

carrello pieghevole in alluminio

Caratteristiche principali:

- Carrello ultracompatto richiudibile in alluminio anodizzato
- Impugnatura con manico telescopico
- Dimensioni aperto: 485x520x1195 mm
- Dimensioni chiuso: 485x60x905 mm
- Dimensioni base ribaltabile 485x350 mm
- Due ruote antiforatura Ø 175 mm
- Cinghia inclusa nella confezione
- Portata massima 120 kg.
- Peso 5,1 kg



C99P

€ 159,00 1 099000101

C99PC

rivestimento interno per coperchio valigette C99V1 e C99V3/2C

Indispensabile in abbinamento ai termoformati per evitare che il contenuto fuoriesca dai vani o si mischi durante il trasporto.



C99PC

€ 15,00 1 099000491

C99T

termoformato portaminuteria a 4 vani per valigette C99V1 e C99V3/2C



C99T

€ 22,00 1 099000492

C99M

inserto soft precubettato per valigette C99V1, C99V2 e C99V3/2C

facile da sagomare per creare alloggiamenti sicuri e su misura per qualsiasi tipo di utensile da contenere

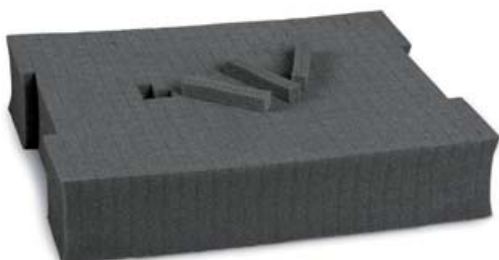

C99M

€ 38,00 1 099000494

C99T-V3

termoformato portaminuteria a 7 vani per cassette portautensili C99C-V3



C99T-V3

€ 11,00 1 099000497

C99P-V3

kit 17 vaschette portaminuteria per cassette portautensili C99C-V3

Composizione:

- 6 vaschette rosse 52x52 mm
- 2 vaschette gialle 104x52 mm
- 3 vaschette grigie 260x78 mm e 6 divisori regolabili



C99P-V3

€ 31,00 1 099000498



C22S

cassettiera portatile
con 3 cassetti

Caratteristiche principali:

- 3 cassetti da 588x277 mm,
- montati su guide telescopiche a sfera:
- 1 cassetto altezza 50 mm
- 2 cassetti altezza 70 mm.
- Serratura centralizzata frontale.
- Maniglie laterali a scomparsa per il trasporto.

19 kg



C22S-O



C22S-G



C22S-R



h	max
50 mm	25 kg
70 mm	25 kg

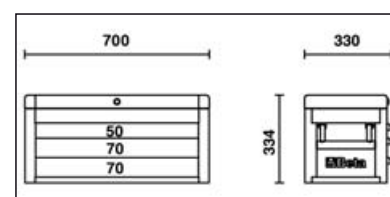
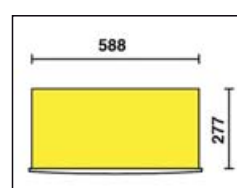

	€		
C22S-O	352,00	1	022000501
C22S-G	352,00	1	022000502
C22S-R	352,00	1	022000503

C23S

cassettiera portatile
con 5 cassetti

Caratteristiche principali:

- 5 cassetti da 588x277 mm,
- montati su guide telescopiche a sfera:
- 2 cassetti altezza 50 mm
- 3 cassetti altezza 70 mm.
- Serratura centralizzata frontale.
- Maniglie laterali a scomparsa per il trasporto.

26 kg



C23S-G



C23S-R



C23S-O



h	max
50 mm	25 kg
70 mm	25 kg

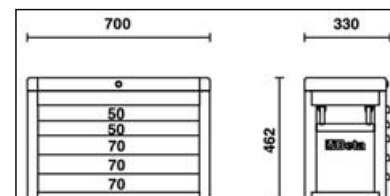
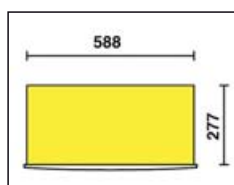

	€		
C23S-O	439,00	1	023000501
C23S-G	439,00	1	023000502
C23S-R	439,00	1	023000503

CD23S

carrello Caddy

Caratteristiche principali:

- Piano di lavoro ricoperto in ABS sul quale sono collocabili a misura le cassettiere C22S, C23S, C23SC, C23ST
- Timone di guida smontabile, collocabile sotto il piano.
- Quattro ruote Ø 100 mm: 2 fisse e 2 girevoli (una con freno).
- Portata massima 250 kg.

14 kg



	€		
CD23S	199,50	1	023000610

C23SC

cassettiera portatile
con 8 cassetti

Caratteristiche principali:

- 8 cassetti montati su guide telescopiche a sfera:
- 4 cassetti altezza 50 mm
- 3 cassetti altezza 70 mm
- 1 cassetto altezza 100 mm.
- Serratura centralizzata frontale.
- Maniglie laterali a scomparsa per il trasporto.

📦 28 kg

	€	📦	🖨️
C23SC-O	495,00	1	023000511
C23SC-G	495,00	1	023000512
C23SC-R	495,00	1	023000513



h	max
50 mm	25 kg
70 mm	25 kg

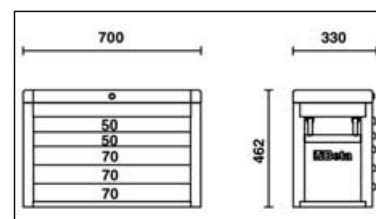
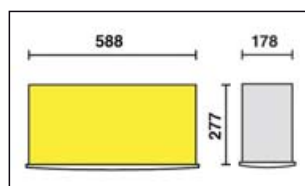

C23ST

cassettiera portatile
con 5 cassetti

Caratteristiche principali:

- 5 cassetti da 588x367 mm, montati su guide telescopiche a sfera:
- 5 cassetti altezza 70 mm
- Serratura centralizzata frontale.
- Possibilità di applicazione del kit 4 ruote più maniglione (2300ST/KIT)

📦 36 kg

	€	📦	🖨️
C23ST-O	542,00	1	023000521
C23ST-G	542,00	1	023000522
C23ST-R	542,00	1	023000523



h	max
70 mm	25 kg

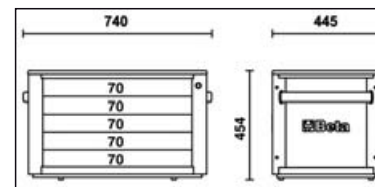
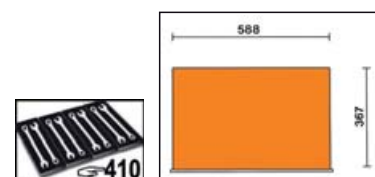

2300ST/KIT

kit con quattro ruote e maniglione per C23ST

- Quattro ruote Ø 125 mm:
- 2 fisse e 2 girevoli (una con freno).
- Maniglione telescopico

📦 6,5 kg

	€	📦	🖨️
2300ST/KIT	161,00	1	023000950



C24S/5

cassettiera mobile con 5 cassetti

Caratteristiche principali:

- 5 cassetti da 588x367 mm, montati su guide telescopiche a sfera:
- 2 cassetti altezza 70 mm
- 2 cassetti altezza 140 mm
- 1 cassetto altezza 280 mm
- Piano dei cassetti protetto da tappetini di gomma espansa.
- Quattro ruote Ø 125 mm: 2 fisse e 2 girevoli (una con freno).
- Serratura di sicurezza centralizzata frontale.
- Capacità di carico statico: 800 kg.
- Piano di lavoro termoplastico sul quale è collocabile a misura una cassetteria C22S, C23S, C23SC e C23ST
- Portaflacone laterale integrato.
- Possibilità di applicazione del portacarta 2400S-R/PC.

52 kg

800 kg



C24S/5-O



C24S/5-G



C24S/5-R

h	max
70 mm	25 kg
140 mm	30 kg
280 mm	35 kg

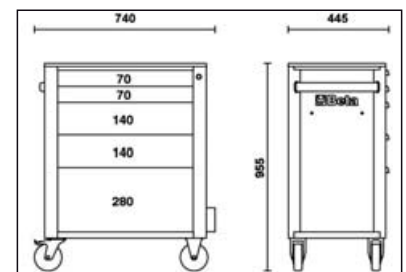
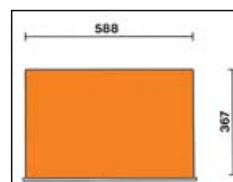

	€		
C24S/5-O	670,00	1	024002051
C24S/5-G	670,00	1	024002052
C24S/5-R	670,00	1	024002053

C24S/6

cassettiera mobile con 6 cassetti

Caratteristiche principali:

- 6 cassetti da 588x367 mm, montati su guide telescopiche a sfera:
- 4 cassetto altezza 70 mm
- 1 cassetto altezza 140 mm
- 1 cassetto altezza 280 mm
- Piano dei cassetti protetto da tappetini di gomma espansa.
- Quattro ruote Ø 125 mm:
- 2 fisse e 2 girevoli (una con freno).
- Serratura di sicurezza centralizzata frontale.
- Capacità di carico statico: 800 kg.
- Piano di lavoro termoplastico sul quale è collocabile a misura una cassettera C22S, C23S, C23SC e C23ST
- Portaflacone laterale integrato.
- Possibilità di applicazione del portacarta 2400S-R/PC.

55 kg

800 kg



C24S/6-O



C24S/6-G



C24S/6-R

h	max
70 mm	25 kg
140 mm	30 kg
280 mm	35 kg

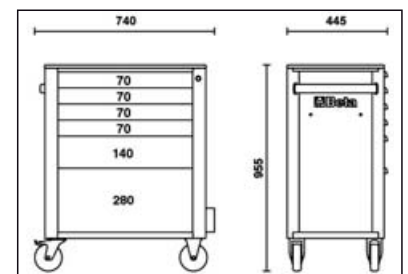
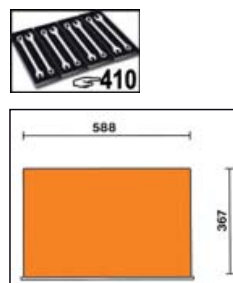

	€		
C24S/6-O	740,00	1	024002061
C24S/6-G	740,00	1	024002062
C24S/6-R	740,00	1	024002063

C24S/7

cassettiera mobile con 7 cassetti

Caratteristiche principali:

- 7 cassetti da 588x367 mm, montati su guide telescopiche a sfera:
- 5 cassetti altezza 70 mm
- 1 cassetto altezza 140 mm
- 1 cassetto altezza 210 mm
- Piano dei cassetti protetto da tappetini di gomma espansa.
- Quattro ruote Ø 125 mm:
- 2 fisse e 2 girevoli (una con freno).
- Serratura di sicurezza centralizzata frontale.
- Capacità di carico statico: 800 kg.
- Piano di lavoro termoplastico sul quale è collocabile a misura una cassettera C22S, C23S, C23SC e C23ST
- Portaflacone laterale integrato.
- Possibilità di applicazione del portacarta 2400S-R/PC.

58 kg

800 kg



C24S/7-O



C24S/7-G



C24S/7-R



C24S/7-B



C24S/7-N

h	max
70 mm	25 kg
140 mm	30 kg
210 mm	30 kg

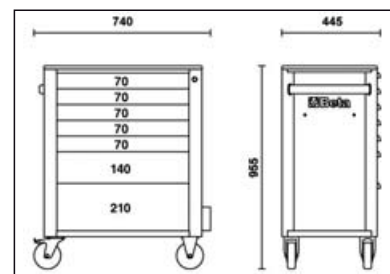
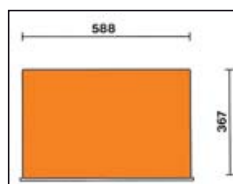

	€		
C24S/7-O	800,00	1	024002071
C24S/7-G	800,00	1	024002072
C24S/7-R	800,00	1	024002073
C24S/7-B	800,00	1	024002076
C24S/7-N	800,00	1	024002079

C24S/8

cassettiera mobile con 8 cassetti

Caratteristiche principali:

- 8 cassetti da 588x367 mm, montati su guide telescopiche a sfera:
- 6 cassetti altezza 70 mm
- 2 cassetti altezza 140 mm
- Piano dei cassetti protetto da tappetini di gomma espansa.
- Quattro ruote Ø 125 mm: 2 fisse e 2 girevoli (una con freno).
- Serratura di sicurezza centralizzata frontale.
- Capacità di carico statico: 800 kg.
- Piano di lavoro termoplastico sul quale è collocabile a misura una cassettera C22S, C23S, C23SC e C23ST
- Portaflacone laterale integrato.
- Possibilità di applicazione del portacarta 2400S-R/PC.

61 kg

800 kg



C24S/8-O



C24S/8-G



C24S/8-R

h	max
70 mm	25 kg
140 mm	30 kg

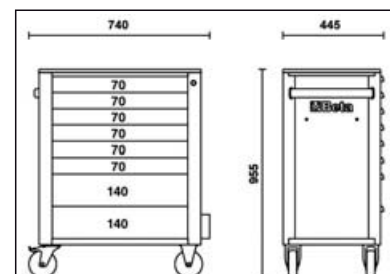
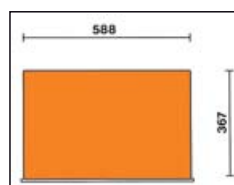

C24S/8-O	€ 860,00	1	024002081
C24S/8-G	€ 860,00	1	024002082
C24S/8-R	€ 860,00	1	024002083

C24SA/6

cassettiera mobile con 6 cassetti,
con sistema antiribaltamento

Caratteristiche principali:

- 6 cassetti da 588x367 mm, montati su guide telescopiche a sfera:
- 4 cassetti altezza 70 mm
- 1 cassetto altezza 140 mm
- 1 cassetto altezza 280 mm
- Piano dei cassetti protetto da tappetini di gomma espansa.
- Quattro ruote Ø 125 mm: 2 fisse e 2 girevoli (una con freno).
- Serratura di sicurezza centralizzata frontale.
- Capacità di carico statico: 800 kg.
- Piano di lavoro termoplastico sul quale è collocabile a misura una cassettiera C22S, C23S, C23SC e C23ST
- Portaflacone laterale integrato.
- Possibilità di applicazione del portacarta 2400S-R/PC.

55 kg

800 kg



C24SA/6-O



C24SA/6-G



C24SA/6-R

h	max
70 mm	25 kg
140 mm	30 kg
280 mm	35 kg

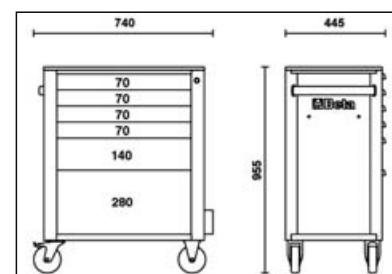
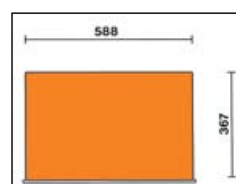

	€		
C24SA/6-O	790,00	1	024002161
C24SA/6-G	790,00	1	024002162
C24SA/6-R	790,00	1	024002163

C24SA/7

cassettiera mobile con 7 cassetti, con sistema antiribaltamento

Caratteristiche principali:

- 7 cassetti da 588x367 mm, montati su guide telescopiche a sfera:
- 5 cassetti altezza 70 mm
- 1 cassetto altezza 140 mm
- 1 cassetto altezza 210 mm
- Piano dei cassetti protetto da tappetini di gomma espansa.
- Quattro ruote Ø 125 mm:
- 2 fisse e 2 girevoli (una con freno).
- Serratura di sicurezza centralizzata frontale.
- Capacità di carico statico: 800 kg.
- Piano di lavoro termoplastico sul quale è collocabile a misura una cassetteria C22S, C23S, C23SC e C23ST
- Portaflacone laterale integrato.
- Possibilità di applicazione del portacarta 2400S-R/PC.

📦 58 kg

800 kg



C24SA/7-O



C24SA/7-G



C24SA/7-R

h	max
70 mm	25 kg
140 mm	30 kg
210 mm	30 kg

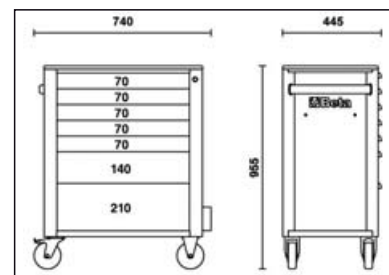
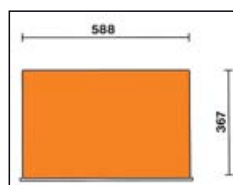

	€	📦	🖨️
C24SA/7-O	845,00	1	024002171
C24SA/7-G	845,00	1	024002172
C24SA/7-R	845,00	1	024002173

C24SA/8

cassettiera mobile con 8 cassetti, con sistema antiribaltamento

Caratteristiche principali:

- 8 cassetti da 588x367 mm, montati su guide telescopiche a sfera:
- 6 cassetti altezza 70 mm
- 2 cassetto altezza 140 mm
- Piano dei cassetti protetto da tappetini di gomma espansa.
- Quattro ruote Ø 125 mm:
- 2 fisse e 2 girevoli (una con freno).
- Serratura di sicurezza centralizzata frontale.
- Capacità di carico statico: 800 kg.
- Piano di lavoro termoplastico sul quale è collocabile a misura una cassettera C22S, C23S, C23SC e C23ST
- Portaflacone laterale integrato.
- Possibilità di applicazione del portacarta 2400S-R/PC.

61 kg



C24SA/8-O



C24SA/8-G



C24SA/8-R

h	max
70 mm	25 kg
140 mm	30 kg

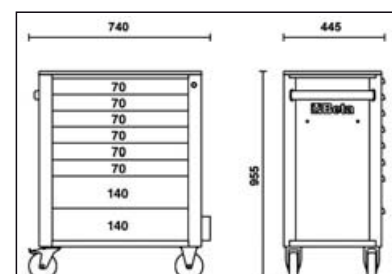
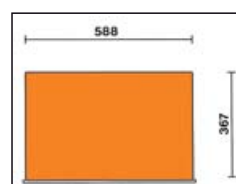

	€		
C24SA/8-O	910,00	1	024002181
C24SA/8-G	910,00	1	024002182
C24SA/8-R	910,00	1	024002183

C24SA-XL/7

cassettiera mobile con 7 cassetti, con sistema antiribaltamento, modello lungo

Caratteristiche principali:

- 7 cassetti da 882x367 mm, montati su guide telescopiche a sfera:
- 5 cassetti altezza 70 mm
- 1 cassetto altezza 140 mm
- 1 cassetto altezza 210 mm
- Piano di lavoro in ABS ad alta resistenza, con 6 vaschette portaminuterie.
- Frontalino in nylon ad alta resistenza, con porta-etichette integrato.
- Piano dei cassetti protetto da tappetini di gomma espansa.
- Quattro ruote Ø 125 mm: 2 fisse e 2 girevoli (una con freno).
- Serratura di sicurezza centralizzata frontale.
- Capacità di carico statico: 1.000 kg.
- Portaflaconi laterale integrato.
- Possibilità di applicazione del portacarta 2400S-R/PC.

84 kg

1000 kg



C24SAXL7-O



C24SAXL7-G



C24SAXL7-R

h	max
70 mm	30 kg
140 mm	35 kg
210 mm	35 kg



	€		
C24SAXL7-O	1.075,00	1	024002271
C24SAXL7-G	1.075,00	1	024002272
C24SAXL7-R	1.075,00	1	024002273

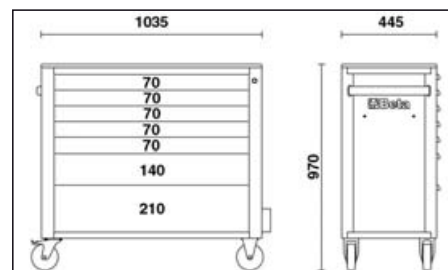
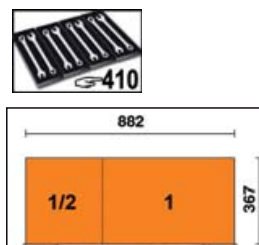

C24SA-XL/8

cassettiera mobile con 8 cassette,
con sistema antiribaltamento,
modello lungo

Caratteristiche principali:

- 8 cassette da 882x367 mm, montati su guide telescopiche a sfera:
- 6 cassette altezza 70 mm
- 2 cassette altezza 140 mm
- Piano di lavoro in ABS ad alta resistenza, con 6 vaschette portaminuterie.
- Frontalino in nylon ad alta resistenza, con porta-etichette integrato.
- Piano dei cassetti protetto da tappetini di gomma espansa.
- Quattro ruote Ø 125 mm:
- 2 fisse e 2 girevoli (una con freno).
- Serratura di sicurezza centralizzata frontale.
- Capacità di carico statico: 1.000 kg.
- Portaflaconi laterale integrato.
- Possibilità di applicazione del portacarta 2400S-R/PC.

88 kg

1000 kg



C24SAXL/8-O



C24SAXL/8-G



C24SAXL/8-R

h	max
70 mm	30 kg
140 mm	35 kg

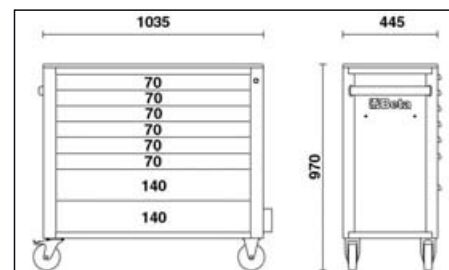
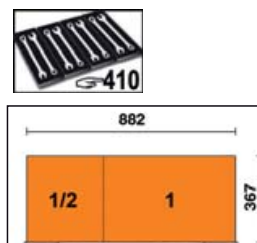

	€		
C24SAXL/8-O	1.150,00	1	024002281
C24SAXL/8-G	1.150,00	1	024002282
C24SAXL/8-R	1.150,00	1	024002283

C24SA-XL/9

cassettiera mobile con 9 cassetti, con sistema antiribaltamento, modello lungo

Caratteristiche principali:

- 9 cassetti da 882x367 mm, montati su guide telescopiche a sfera:
- 8 cassetti altezza 70 mm
- 1 cassetto altezza 140 mm
- Piano di lavoro in ABS ad alta resistenza, con 6 vaschette portaminuterie.
- Frontalino in nylon ad alta resistenza, con porta-etichette integrato.
- Piano dei cassetti protetto da tappetini di gomma espansa.
- Quattro ruote Ø 125 mm: 2 fisse e 2 girevoli (una con freno).
- Serratura di sicurezza centralizzata frontale.
- Capacità di carico statico: 1.000 kg.
- Portaflaconi laterale integrato.
- Possibilità di applicazione del portacarta 2400S-R/PC.

90 kg

1000 kg



C24SAXL/9-O



C24SAXL/9-G



C24SAXL/9-R

h	max
70 mm	30 kg
140 mm	35 kg



	€		
C24SAXL/9-O	1.220,00	1	024002331
C24SAXL/9-G	1.220,00	1	024002332
C24SAXL/9-R	1.220,00	1	024002333

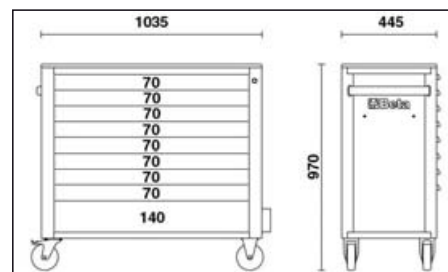
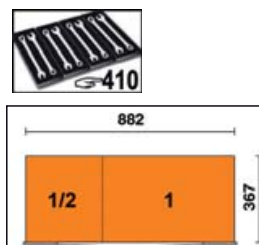

2400S-R/PC

portacarta per rotoli preforati

- Abbinabile alle cassettiere serie C24S

0,3 kg

	€		
2400SR/PC-O	17,00	1	024002951
2400SR/PC-G	17,00	1	024002952
2400SR/PC-R	17,00	1	024002953



- 2400S R/PC-O
- 2400S R/PC-G
- 2400S R/PC-R



2400S/PF

portaflaconi

- Abbinabile alle cassettiere serie C24S

0,5 kg

	€		
2400S/PF	18,00	1	024002906



2499PF

portaflaconi

- Abbinabile alle cassettiere serie C38

2,5 kg

	€		
2499PF-O	58,00	1	024990210
2499PF-G	58,00	1	024990219
2499PF-R	58,00	1	024990230

2499PF O

2499PF G

2499PF R



2499PF/M

portaflaconi universale magnetico

2,2 kg

	€		
2499PF/M	48,00	1	024990050



2499PC

portacarta per rotoli preforati

- Abbinabile a tutti i carrelli Tank C25 e alle cassettiere serie C38 e C38A.

2,2 kg

	€		
2499PC	61,00	1	024990090



C24SL

cassettiera mobile
con 7 cassetti
e ripiani laterali

Caratteristiche principali:

- 7 cassetti da 588x367 mm, montati su guide telescopiche a sfera:
- 5 cassetti altezza 70 mm
- 1 cassetto altezza 140 mm
- 1 cassetto altezza 210 mm.
- Piano dei cassetti protetto da tappetini di gomma espansa.
- Quattro ruote Ø 125 mm:
- 2 fisse e 2 girevoli (due con freno).
- Serratura centralizzata frontale.
- Capacità di carico statico: 1.100 kg.
- Piano di lavoro in legno multistrato con fori per la collocazione di una morsa (1599F/100 da ordinare separatamente).
- Vano laterale con ripiano regolabile in altezza.
- Portacarta integrato.
- Doppio portaflaconi posteriore.

80 kg

	€		
C24SL-O	1.190,00	1	024002101
C24SL-G	1.190,00	1	024002102
C24SL-R	1.190,00	1	024002103



1100 kg



C24SL-G



C24SL-R



C24SL-O

h	max
70 mm	25 kg
140 mm	30 kg
210 mm	30 kg

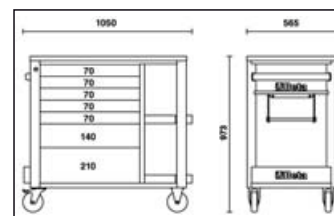
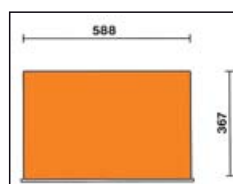

C24SL-CAB

cassettiera mobile
con sette cassetti
e armadietto porta-oggetti

Caratteristiche principali:

- Sette cassetti da 588x367 mm, montati su guide telescopiche a sfera:
- 5 cassetti altezza 70 mm
- 1 cassetto altezza 140 mm
- 1 cassetto altezza 210 mm.
- Piano dei cassetti protetto da tappetini di gomma espansa.
- Quattro ruote Ø 125 mm:
- 2 fisse e 2 girevoli (due con freno).
- Serratura centralizzata frontale.
- Armadietto laterale portaoggetti con anta richiudibile con serratura e ripiano interno regolabile in altezza.
- Capacità di carico statico: 1.100 kg.
- Piano di lavoro in legno multistrato con fori per la collocazione di una morsa (1599F/100 da ordinare separatamente).
- Portacarta integrato.
- Doppio portaflaconi posteriore.

82 kg

	€		
C24SL-CAB/O	1.225,00	1	024002191
C24SL-CAB/G	1.225,00	1	024002192
C24SL-CAB/R	1.225,00	1	024002193



1100 kg



C24SL-CAB/G



C24SL-CAB/R



C24SL-CAB/O

h	max
70 mm	25 kg
140 mm	30 kg
210 mm	30 kg

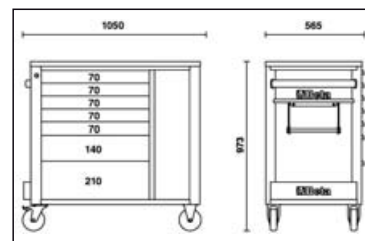
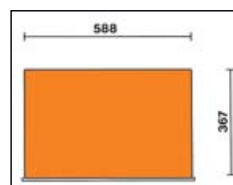

C04TSS-7

cassettiera mobile con sette cassetti
in acciaio inossidabile, con ruote antitraccia

Caratteristiche principali:

- Sette cassetti da 570 x 410 mm montati su guide telescopiche a sfera;
- 6 cassetti altezza 83 mm;
- 1 cassetto altezza 170 mm;
- quattro ruote antitraccia con nucleo in acciaio inossidabile Ø 125mm 2 fisse e 2 girevoli (due con freno);
- Serratura frontale centralizzata;
- Struttura interamente in acciaio inossidabile AISI 304
- Ruote, supporti, sfere, interno dei cassetti e relative guide in acciaio inossidabile
- Maniglia cassetti in alluminio

📦 63 kg



700
kg

Beta
INOX
STAINLESS STEEL

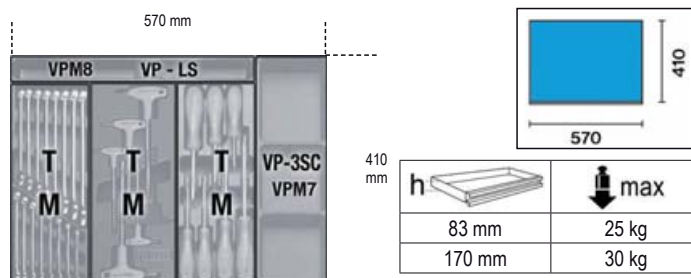

C04TSS/7

€ 2.160,00 1 024003077 279

C25

carrello Tank con mensola

Caratteristiche principali:

- Coperchio di chiusura ribaltabile.
- 1 cassetto scorrevole.
- Piano di alloggiamento utensili protetto da tappetini di gomma espansa.
- Piani di servizio protetti con tappetini in gomma antiolio e antibenzina.
- Quattro ruote Ø 100 mm: 2 fisse e 2 girevoli (una con freno).
- Serratura centralizzata frontale.
- Termoformato vuoto per bussole e accessori da 1/2" (024990104)
- Possibilità di applicazione del portacarta 2499PC.

📦 31,5 kg

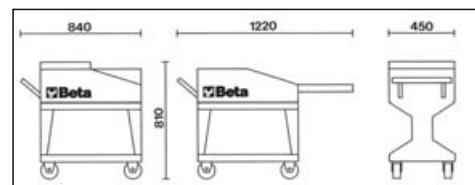

C25

€ 498,00 1 025000001

C27S

carrello portautensili richiudibile per interventi esterni

Struttura in lamiera.

Carrello richiudibile con colonnine ribaltabili per permettere un agevole trasporto.

Modello registrato.

2 cassette 588x277 mm montate su guide telescopiche che permettono l'apertura in due sensi.

Ampio vano portaoggetti inferiore 588x277x220 mm.

2 ruote fisse Ø 160 mm e 2 ruote piroettanti con freno Ø 100 mm

Piano di lavoro termoplastico con 6 vaschette portaminuterie integrate.

Chiusura centralizzata.

Predisposizione per l'alloggiamento di separatori per cassetto e termoformati portautensili MC.

📦 20 kg



C27S-O



C27S-G



C27S-R



h	max
70 mm	20 kg

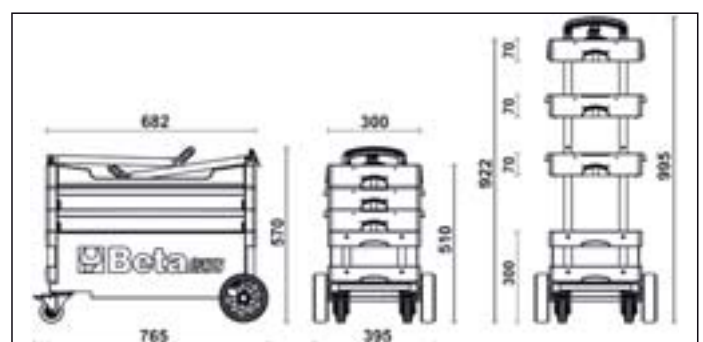
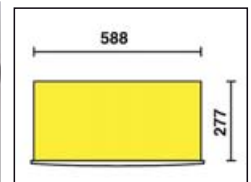

	€	📦	🖨️
C27S-O	558,00	1	027000201
C27S-G	558,00	1	027000202
C27S-R	558,00	1	027000203

C28

carrello SuperTank con piano di lavoro e 10 cassetti

Caratteristiche principali:

- 10 cassetti da 588x367 mm, montati su guide telescopiche a sfera.
- Sistema rapido e sicuro per l'apertura e chiusura dei cassetti con frontalino in nylon e fibra di vetro.
- Cinque cassetti laterali di cui:
 - 4 cassetti altezza 70 mm
 - 1 cassetto altezza 210 mm.
- Cinque cassetti frontali di cui:
 - 4 cassetti altezza 70 mm
 - 1 cassetto altezza 210 mm.
- Piano dei cassetti protetto da tappetini di gomma espansa.
- Quattro ruote ad alta portata Ø 150 mm: 2 fisse e 2 girevoli con freno.
- 2 serrature di sicurezza centralizzate.
- 3 cassettini frontali portaoggetti.
- Piano di lavoro in legno multistrato con fori per la collocazione di una morsa (1599F/150 da ordinare separatamente).
- Vano integrato portaminuterie.
- Vano laterale con antina di chiusura a scomparsa con serratura.
- Portaflaconi integrati.
- Vano passante altezza 135 mm con base ricoperta in materiale plastico.
- Capacità di carico statico: kg 1200.

130 kg

1200
kg



C28-O



C28-G



C28-R



h	max
70 mm	25 kg
210 mm	30 kg

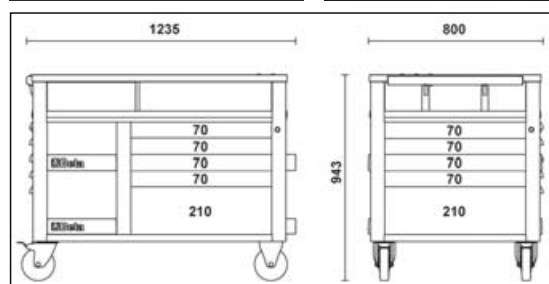
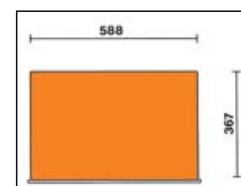

	€		
C28-O	2.110,00	1	028000301
C28-G	2.110,00	1	028000302
C28-R	2.110,00	1	028000303

C30S

postazione di lavoro mobile MaxiTank

Caratteristiche principali:

- 5 cassetti frontali montati su guide telescopiche a sfera:
 - 3 cassetti 367x588 mm, altezza 90 mm
 - 1 cassetto 610x588 mm, altezza 90 mm
 - 1 cassetto 610x588 mm, altezza 180 mm
- Sistema di apertura rapido con frontalino in alluminio.
- Piano dei cassetti protetto da tappetini di gomma espansa.
- Predisposizione per l'inserimento di termoformati.
- Un martinetto idraulico consente, senza sforzo, il sollevamento della parte anteriore e quindi un trasporto agevole.
- Quattro ruote ad alta portata:
 - 2 girevoli, anteriori, Ø 150 mm
 - 2 fisse, posteriori, Ø 170 mm.
- Piano di lavoro ricoperto in gomma antiolio 1300x800 mm con foro di scarico per la raccolta di liquidi in un piccolo serbatoio.
- Vano passante 720x250x1300 mm con piano ricoperto in PVC, chiuso frontalmente da antine a scomparsa.
- Chiusura centralizzata per cassetti e antine.
- 3 portafiacconi laterali integrati.
- Portacarta integrato
- Capacità di carico statico: kg 1800.
- Predisposizione per la collocazione di un piano di lavoro in legno multistrato (3000 S/PLM) da ordinare separatamente
- Possibilità di collocazione di una morsa 1599F/150. (da ordinare separatamente)

📦 200 kg

1800 kg

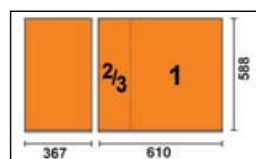

h	max
90 mm	30 kg
180 mm	35 kg

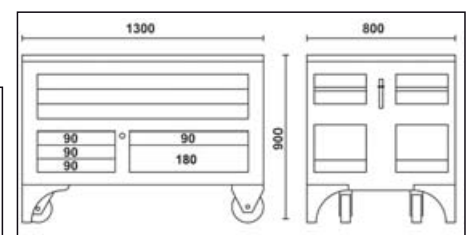

C30S

€ 3.390,00 1 030000100

3000S/PLM

piano di lavoro in legno per C30S
con fori per la collocazione di una morsa 1599F/150

📦 10 kg

€ 355,00 1 030000150



1240x740x26 mm

C35/6G

cassettiera fissa industriale con 6 cassetti

Caratteristiche principali:

- 6 cassetti da 600x447 mm ad estrazione totale:
- 2 cassetti altezza 75 mm
- 1 cassetto altezza 100 mm
- 1 cassetto altezza 150 mm
- 1 cassetto altezza 200 mm
- 1 cassetto altezza 300 mm
- Serratura di sicurezza centralizzata frontale.
- Predisposizione per piano di lavoro e separatori per i cassetti, da ordinare separatamente

📦 73,5 kg



h	max
75 mm	70 kg
100 mm	70 kg
150 mm	70 kg
200 mm	70 kg
300 mm	70 kg

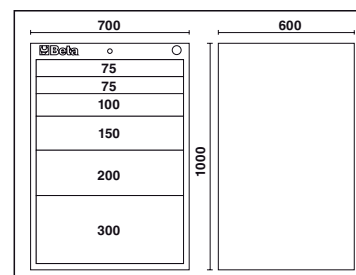
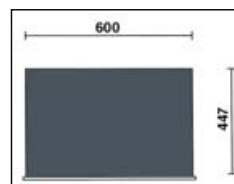

C35/6G

€ 930,00



1 035000062

C35/7G

cassettiera fissa industriale con 7 cassetti

Caratteristiche principali:

- 7 cassetti da 600x447 mm ad estrazione totale:
- 2 cassetti altezza 75 mm
- 1 cassetto altezza 100 mm
- 3 cassetti altezza 150 mm
- 1 cassetto altezza 200 mm
- Serratura di sicurezza centralizzata frontale.
- Predisposizione per piano di lavoro e separatori per i cassetti, da ordinare separatamente

📦 77 kg



h	max
75 mm	70 kg
100 mm	70 kg
150 mm	70 kg
200 mm	70 kg

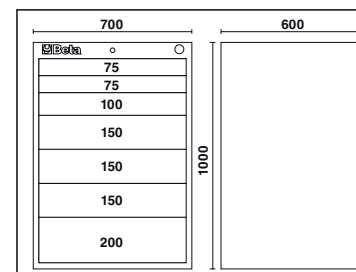
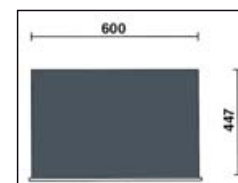

C35/7G

€ 970,00



1 035000072

C35/8G

cassettiera fissa industriale con 8 cassetti

Caratteristiche principali:

- 8 cassetti da 600x447 mm ad estrazione totale:
- 4 cassetti altezza 75 mm
- 1 cassetto altezza 100 mm
- 2 cassetti altezza 150 mm
- 1 cassetto altezza 200 mm
- Serratura di sicurezza centralizzata frontale.
- Predisposizione per piano di lavoro e separatori per i cassetti, da ordinare separatamente

80,5 kg

1200 kg



h	max
75 mm	70 kg
100 mm	70 kg
150 mm	70 kg
200 mm	70 kg

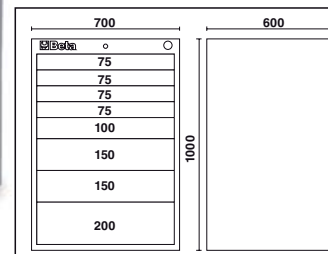
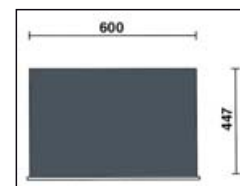

C35/8G € 1.035,00 1 035000082

C35/9G

cassettiera fissa industriale con 9 cassetti

Caratteristiche principali:

- 6 cassetti altezza 75 mm
- 3 cassetti altezza 150 mm
- Serratura di sicurezza centralizzata frontale.
- Predisposizione per piano di lavoro e separatori per i cassetti, da ordinare separatamente

84 kg

1200 kg



h	max
75 mm	70 kg
150 mm	70 kg

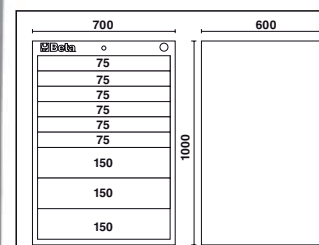
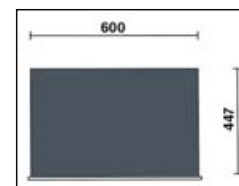

C35/9G € 1.085,00 1 035000092

3500/P

piano di lavoro con bordo perimetrale per cassetta C35

3500/P 700x600 mm € 80,00 1 035000502



3500/D

adattatori per cassetto C35

Permettono di adattare la dimensione del cassetto della cassetta C35 per poter utilizzare tutti i termoformati standard 588x367mm

- 2 vaschette porta minuteria mm 75x75x52h;
- 3 vaschette porta minuteria mm 150x75x52h;
- 1 divisorio longitudinale fessurato.



3500/D € 24,00 1 035000503

C37/6

cassettiera mobile
con 6 cassetti

Caratteristiche principali:

- 6 cassetti da 588x367 mm, montati su guide telescopiche a sfera:
- 4 cassetti altezza 75 mm
- 1 cassetto altezza 150 mm
- 1 cassetto altezza 305 mm
- Piano di lavoro multifunzione ad alta resistenza.
- Portaminuterie e fori per l'alloggiamento dei giravite.
- Sistema di apertura a sgancio rapido in alluminio posizionato su tutta la lunghezza del cassetto.
- Paracolpi angolari morbidi su tutta l'altezza della cassettiera per evitare, in caso di urto, il danneggiamento dei veicoli all'interno dell'officina.
- Piano dei cassetti protetto da tappetini di gomma espansa.
- Quattro ruote Ø 125 mm: 2 fisse e 2 girevoli (una con freno).
- Serratura di sicurezza centralizzata frontale.
- Capacità di carico statico: 1000 kg.
- Portaflaconi e portacarta laterali integrati regolabili in più posizioni.

69 kg

1000 kg



C37/6-O



C37/6-G



C37/6-R

h	max
75 mm	30 kg
150 mm	35 kg
305 mm	40 kg

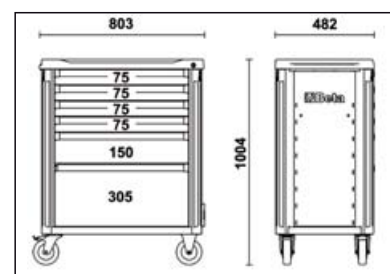
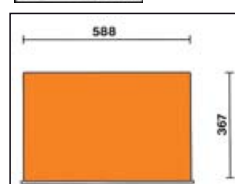

	€		
C37/6-O	890,00	1	037000061
C37/6-G	890,00	1	037000062
C37/6-R	890,00	1	037000063

C37/7

cassettiera mobile
con 7 cassetti

Caratteristiche principali:

- 7 cassetti da 588x367 mm, montati su guide telescopiche a sfera:
- 5 cassetti altezza 75 mm
- 1 cassetto altezza 150 mm
- 1 cassetto altezza 225 mm
- Piano di lavoro multifunzione ad alta resistenza.
- Portaminuterie e fori per l'alloggiamento dei giravite.
- Sistema di apertura a sgancio rapido in alluminio posizionato su tutta la lunghezza del cassetto.
- Paracolpi angolari morbidi su tutta l'altezza della cassettiera per evitare, in caso di urto, il danneggiamento dei veicoli all'interno dell'officina.
- Piano dei cassetti protetto da tappetini di gomma espansa.
- Quattro ruote Ø 125 mm: 2 fisse e 2 girevoli (una con freno).
- Serratura di sicurezza centralizzata frontale.
- Capacità di carico statico: 1000 kg.
- Portaflaconi e portacarta laterali integrati regolabili in più posizioni.

71 kg

1000
kg



C37/7-O



C37/7-G



C37/7-R

h	max
75 mm	30 kg
150 mm	35 kg
225 mm	35 kg

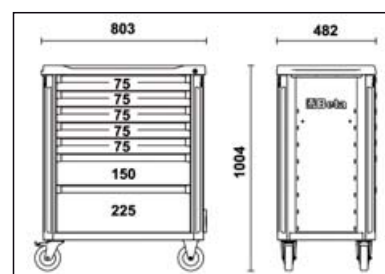
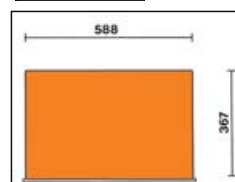

C37/7-O	€ 920,00	1	037000071
C37/7-G	€ 920,00	1	037000072
C37/7-R	€ 920,00	1	037000073

C37/8

cassettiera mobile
con 8 cassetti

Caratteristiche principali:

- 8 cassetti da 588x367 mm, montati su guide telescopiche a sfera:
- 6 cassetti altezza 75 mm
- 2 cassetti altezza 150 mm
- Piano di lavoro multifunzione ad alta resistenza.
- Portaminuterie e fori per l'alloggiamento dei giravite.
- Sistema di apertura a sgancio rapido in alluminio posizionato su tutta la lunghezza del cassetto.
- Paracolpi angolari morbidi su tutta l'altezza della cassettiera per evitare, in caso di urto, il danneggiamento dei veicoli all'interno dell'officina.
- Piano dei cassetti protetto da tappetini di gomma espansa.
- Quattro ruote Ø 125 mm: 2 fisse e 2 girevoli (una con freno).
- Serratura di sicurezza centralizzata frontale.
- Capacità di carico statico: 1000 kg.
- Portaflaconi e portacarta laterali integrati regolabili in più posizioni.

73 kg

1000 kg



C378-O



C37/8-G



C37/8-R

h	max
75 mm	30 kg
150 mm	35 kg

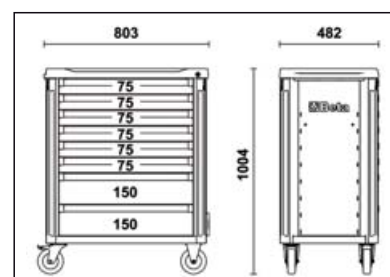
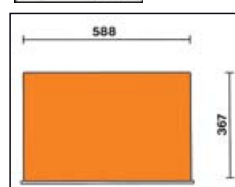

C37/8-O	€ 955,00	1	037000081
C37/8-G	€ 955,00	1	037000082
C37/8-R	€ 955,00	1	037000083

C37A/7

cassettiera mobile
con 7 cassetti con sistema antiribaltamento

Caratteristiche principali:

- 7 cassetti da 588x367 mm, montati su guide telescopiche a sfera:
- 5 cassetti altezza 75 mm
- 1 cassetto altezza 150 mm
- 1 cassetto altezza 225 mm
- Piano di lavoro multifunzione ad alta resistenza.
- Portaminuterie e fori per l'alloggiamento dei giravite.
- Sistema di apertura a sgancio rapido in alluminio posizionato su tutta la lunghezza del cassetto.
- Paracolpi angolari morbidi su tutta l'altezza della cassettiera per evitare, in caso di urto, il danneggiamento dei veicoli all'interno dell'officina.
- Piano dei cassetti protetto da tappetini di gomma espansa.
- Quattro ruote Ø 125 mm:
- 2 fisse e 2 girevoli (una con freno).
- Serratura di sicurezza centralizzata frontale.
- Capacità di carico statico: 1000 kg.
- Portaflaconi e portacarta laterali integrati regolabili in più posizioni.

1000 kg



C3717-O

71 kg



C3717-G



C3717-R

h	max
75 mm	30 kg
150 mm	35 kg
225 mm	35 kg

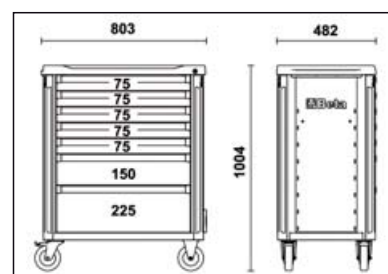
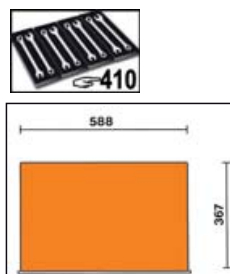

	€		
C37A/7-O	945,00	1	037000271
C37A/7-G	945,00	1	037000272
C37A/7-R	945,00	1	037000273

3700/PLA

piano di lavoro in acciaio inossidabile per cassetiera C37

2,8 kg

3700/PLA € 55,00 1 037000100



672x396x1,5 mm

3700/PLL

piano di lavoro in legno per cassetiera C37

Con predisposizione per la collocazione di una morsa 1599P/100 (da ordinare separatamente)

3,9 kg

3700/PLL € 69,00 1 037000101



672x396x28 mm

3700/PF

pannello forato con supporti per cassetiera C37

3,2 kg

3700/PF € 54,00 1 037000102



626
50
650



3700/PFL

pannello forato laterale per cassetiera C37

1,9 kg

3700/PFL € 29,50 1 037000104

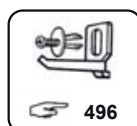

754
50
321



3700/PC

supporto porta computer per cassetiera C37

Con cassetto estraibile

3,1 kg

3700/PC € 74,00 1 037000103

303
300
418



C38

cassettiera mobile
con 11 cassetti

Caratteristiche principali:

- 11 cassetti montati su guide telescopiche a sfera:
- 1 cassetto 937x410x122 mm
- 3 cassetti 570x410x74 mm
- 2 cassetti 570x410x153 mm
- 3 cassetti 313x410x74 mm
- 2 cassetti 313x410x153 mm.
- Piano dei cassetti protetto da tappetini di gomma espansa.
- Capacità di carico statico: 1200 kg.
- 4 ruote ad alta portata Ø 125 mm:
- 2 fisse e 2 girevoli (entrambe con freno a leva).
- Serratura centralizzata frontale.
- Piano di lavoro di lamiera ricoperto da tappetino in gomma.
- Possibilità di applicazione del portacarta 2499PC e del portafaconi 2499PF.

1200
kg



C38-G



C38-R



C38-O



h	max
74 mm	25 kg
153 mm	30 kg

114 kg

	€		
C38-O	1.460,00	1	038000001
C38-G	1.460,00	1	038000003
C38-R	1.460,00	1	038000002

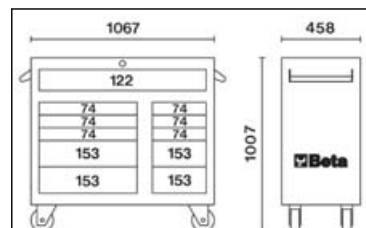
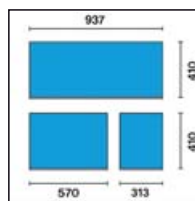

C38L

cassettiera laterale con 7 cassetti

Caratteristiche principali:

- 7 cassetti da 410x313 mm, montati su guide telescopiche a sfera: 5 cassetti altezza 74 mm
- 2 cassetti altezza 153 mm.
- Piano dei cassetti protetto da tappetini di gomma espansa.
- Serratura di sicurezza centralizzata frontale.
- Piano di lavoro in alluminio antiscivolo.
- Agganciabile su entrambi i lati di C38 e C38A.

45 kg

	€		
C38L-O	705,00	1	038000081
C38L-G	705,00	1	038000083
C38L-R	705,00	1	038000082



C38L-O



C38L-G



C38L-R

h	max
74 mm	25 kg
153 mm	30 kg

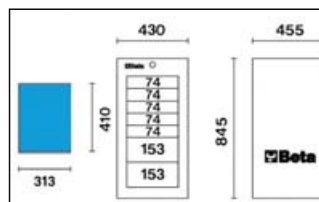

C38LA

antina laterale
con scaffale interno

Caratteristiche principali:

- Serratura frontale.
- Scaffale interno regolabile in altezza.
- Tasca portadocumenti posizionata all'interno dell'antina.
- Piano di lavoro in alluminio antiscivolo.
- Agganciabile su entrambi i lati di C38 e C38A.

18 kg

	€		
C38LA O	270,00	1	038000071
C38LA G	270,00	1	038000073
C38LA R	270,00	1	038000072



C38LA-O



C38LA-G



C38LA-R

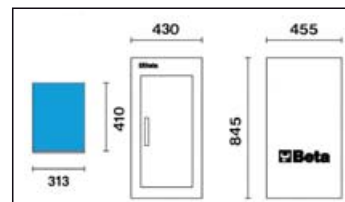

C38C

cassettiera mobile con 33 cassetti
composta da:

- 1 cassetiera mobile C38
- 2 cassetiere laterali C38L
- 1 cassetiera top C38T

📦 268 kg



C38C-O



C38C-G



C38C-R



h	max
74 mm	25 kg
153 mm	30 kg

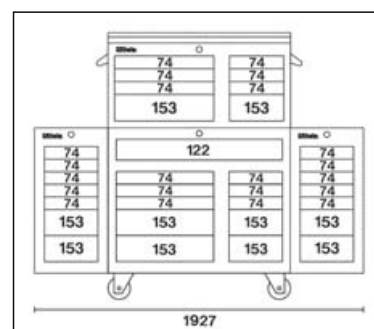
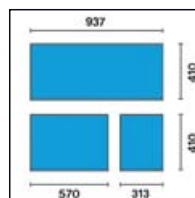

	€	📦	🏠
C38C-O	3.790,00	1	038000201
C38C-G	3.790,00	1	038000203
C38C-R	3.790,00	1	038000202

C38T

cassettiera top
con 8 cassetti e vano portautensili

Caratteristiche principali:

- 8 cassetti montati su guide telescopiche a sfera:
- 3 cassetti 570x410x74 mm
- 1 cassetto 570x410x153 mm
- 3 cassetti 313x410x74 mm
- 1 cassetto 313x410x153 mm.
- Vano portautensili.
- Piano dei cassetti protetto da tappetini di gomma espansa.
- Serratura di sicurezza centralizzata frontale.
- Collocabile sul piano di lavoro di C38 e C38A.

📦 64 kg



C38T-O



C38T-G



C38T-R

h	max
74 mm	25 kg
153 mm	30 kg

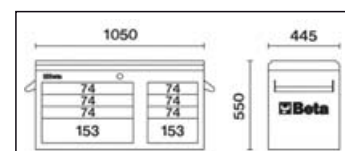
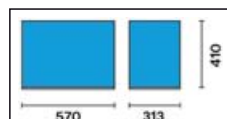

	€	📦	🏠
C38T-O	915,00	1	038000091
C38T-G	915,00	1	038000093
C38T-R	915,00	1	038000092

C39/6

cassettiera mobile con 6 cassetti

Caratteristiche principali:

- 6 cassetti da 588x367 mm, montati su guide telescopiche a sfera:
- 4 cassetti altezza 70 mm
- 1 cassetto altezza 140 mm
- 1 cassetto altezza 280 mm
- Piano dei cassetti protetto da tappetini di gomma espansa.
- Quattro ruote Ø 125 mm:
- 2 fisse e 2 girevoli (una con freno).
- Serratura di sicurezza centralizzata frontale.
- Sistema di apertura posizionato su tutta la lunghezza del cassetto.
- Capacità di carico statico: 1200 kg.
- Piano di lavoro termoplastico.
- Portaflaconi laterali e posteriori integrati.
- Portacarta integrato.
- Struttura portante in alluminio

📦 59 kg

1200 kg



C39-6/G



C39-6/R



C39-6/O

h	max
70 mm	30 kg
140 mm	35 kg
280 mm	40 kg

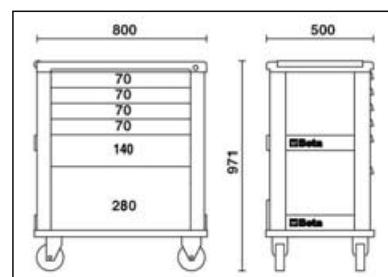
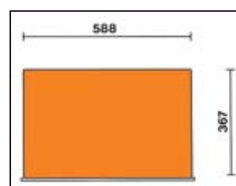

	€	📦	🖨️
C39-6/O	1.295,00	1	039000031
C39-6/G	1.295,00	1	039000032
C39-6/R	1.295,00	1	039000033

C39T

cassettiera portatile con 4 cassetti

Caratteristiche principali:

- 4 cassetti da 588x367 mm, montati su guide telescopiche a sfera:
- 4 cassetti altezza 70 mm
- Serratura centralizzata frontale.
- Montanti e frontalino del cassetto in alluminio.

📦 29 kg



C39T-O



C39T-G



C39T-R



h	max
70 mm	30 kg

	€	📦	🖨️
C39T-O	875,00	1	039000101
C39T-G	875,00	1	039000102
C39T-R	875,00	1	039000103

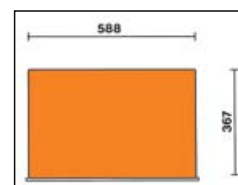
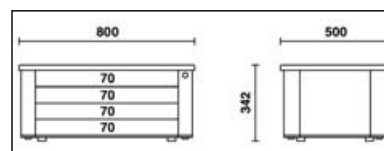

C39/7

cassettiera mobile
con 7 cassetti

Caratteristiche principali:

- 7 cassetti da 588x367 mm, montati su guide telescopiche a sfera:
- 5 cassetti altezza 70 mm
- 1 cassetto altezza 140 mm.
- 1 cassetto altezza 210 mm
- Piano dei cassetti protetto da tappetini di gomma espansa.
- Quattro ruote Ø 125 mm:
- 2 fisse e 2 girevoli (una con freno).
- Serratura di sicurezza centralizzata frontale.
- Sistema di apertura posizionato su tutta la lunghezza del cassetto.
- Capacità di carico statico: 1200 kg.
- Piano di lavoro termoplastico.
- Portaflaconi laterali e posteriori integrati.
- Portacarta integrato.
- Struttura portante in alluminio

61 kg

1200
kg



C39-7/O



C39-7/G



C39-7/R

h	max
70 mm	30 kg
140 mm	35 kg
210 mm	35 kg

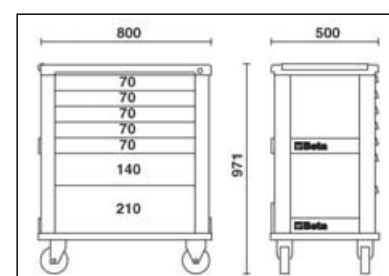
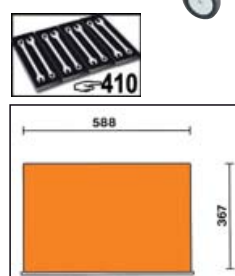

	€		
C39-7/O	1.370,00	1	039000001
C39-7/G	1.370,00	1	039000002
C39-7/R	1.370,00	1	039000003

C39/8

cassettiera mobile con 8 cassetti

Caratteristiche principali:

- 8 cassetti da 588x367 mm, montati su guide telescopiche a sfera:
- 6 cassetti altezza 70 mm
- 2 cassetti altezza 140 mm
- Piano dei cassetti protetto da tappetini di gomma espansa.
- Quattro ruote Ø 125 mm: 2 fisse e 2 girevoli (una con freno).
- Serratura di sicurezza centralizzata frontale.
- Sistema di apertura posizionato su tutta la lunghezza del cassetto.
- Capacità di carico statico: 1200 kg.
- Piano di lavoro termoplastico.
- Portaflaconi laterali e posteriori integrati.
- Portacarta integrato.
- Struttura portante in alluminio

64 kg

1200 kg



C39-8/O



C39-8/G



C39-8/R

h	max
70 mm	30 kg
140 mm	35 kg

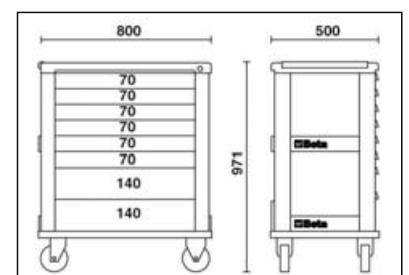
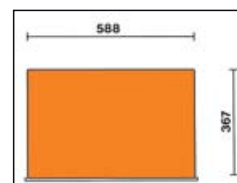

	€		
C39-8/O	1.460,00	1	039000041
C39-8/G	1.460,00	1	039000042
C39-8/R	1.460,00	1	039000043

2200-COVER C22S

Protezione in nylon per cassettera portatile C22S



2200-COVER C22S

€ 15,00 1 022000910

2300-COVER C23S

Protezione in nylon per cassettera portatile C23S



2300-COVER C23S

€ 16,00 1 023000920

2300-COVER C23ST

Protezione in nylon per cassettera portatile C23ST



2300-COVER C23ST

€ 17,50 1 023000930

2400-COVER C24S

Protezione in nylon per cassettera mobile C24S/SA - C39



2400-COVER C24S

€ 18,00 1 024000910

2400-COVER C24SA-XL

Protezione in nylon per cassettera mobile C24SA-XL, C24SL, C24SL-CAB



2400-COVER C24SA-XL

€ 24,50 1 024000930

3700-COVER C37

Protezione in nylon per cassettera mobile C37



3700-COVER C37

€ 24,00 1 037000930

4100-COVER C41H

Protezione in nylon per cassettera mobile C41H



4100-COVER C41H

€ 19,00 1 041000930

C39SM

cassettiera speciale mobile tipo Racing SM

Caratteristiche tecniche

- Piano di lavoro in legno multistrato
- Serratura di sicurezza centralizzata frontale.
- 4 ruote Ø 125 mm
- 2 fisse e 2 girevoli (una con freno) con copertura a vista
- Capacità di carico statico: 1200 Kg

Modulo con 7 cassetti

da 588x367 mm, montati

su guide telescopiche a sfera:

6 cassetti altezza 70 mm

1 cassetto altezza 240 mm

• Piano dei cassetti protetto da tappetini di gomma espansa.

• Sistema di apertura posizionato su tutta la lunghezza del cassetto.

• Frontalino del cassetto in alluminio.

Modulo di servizio

• Cestino portarifiuti integrato

• Vano portacarta per rotoli integrato

• 1 cassetto portaoggetti 380x305x270 mm

125 kg

	€		
C39SM-O	2.230,00	1	039390001
C39SM-G	2.230,00	1	039390002
C39SM-R	2.230,00	1	039390003

1200 kg



C39SM-G



C39SM-R



C39SM-O



h	max
70 mm	30 kg
240 mm	40 kg

h	max
70 mm	30 kg
240 mm	40 kg

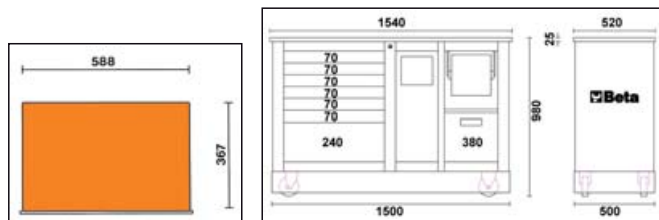

C39MD

cassettiera speciale mobile Racing MD

Caratteristiche tecniche

- Piano di lavoro in legno multistrato
- Serratura di sicurezza centralizzata frontale.
- 4 ruote Ø 125 mm
- 2 fisse e 2 girevoli (una con freno) con copertura a vista
- Capacità di carico statico: 1200 Kg

Modulo con 7 cassetti

da 588x367 mm, montati

su guide telescopiche a sfera:

6 cassetti altezza 70 mm

1 cassetto altezza 240 mm

• Piano dei cassetti protetto da tappetini di gomma espansa.

• Sistema di apertura posizionato su tutta la lunghezza del cassetto.

• Frontalino del cassetto in alluminio.

Modulo con 2 cassetti

da 588x367x270 mm e 588x367x380 mm, montati su guide telescopiche a sfera

• Piano dei cassetti protetto da tappetini di gomma espansa

• Sistema di apertura posizionato su tutta la lunghezza dei cassettoni

• Frontalino dei cassettoni in alluminio.

123 kg

	€		
C39MD-O	2.295,00	1	039390101
C39MD-G	2.295,00	1	039390102
C39MD-R	2.295,00	1	039390103

1200 kg



C39MD-G



C39MD-R



C39MD-O



h	max
70 mm	30 kg
240 mm	40 kg

h	max
70 mm	30 kg
240 mm	40 kg

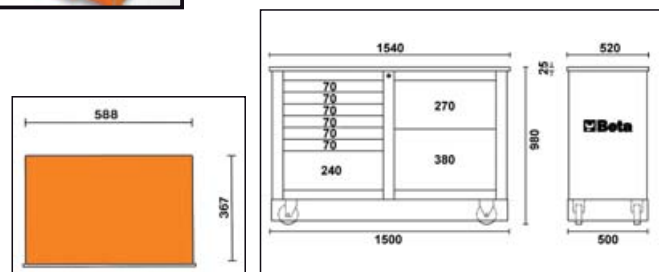

C41S

trolley portautensili
a 2 moduli sovrapponibili

Caratteristiche principali:

- Struttura in lamiera e piani in materiale plastico: grande robustezza e peso ridotto.
- 2 moduli separabili:
 - 1 cestello superiore,
 - 1 modulo con 1 cassetto altezza 95 mm e 1 cassetto altezza 295 mm.
- Ruote di grosso diametro (160 mm), integrate nella struttura per facilitare il trasporto anche su gradini.
- Serratura centralizzata laterale per la chiusura dei 2 cassetti del modulo inferiore.
- Cassetti montati su guide telescopiche a sfera con doppio gancio di chiusura.
- Impugnatura con manico telescopico in alluminio.
- Portaminuterie integrato nel cestello superiore.
- Cassetto inferiore con doppia guida telescopica
- Assortimenti consigliati: 5940/SBK e 5915VU/5

16 kg

C41S

€ 415,00 1 041000001

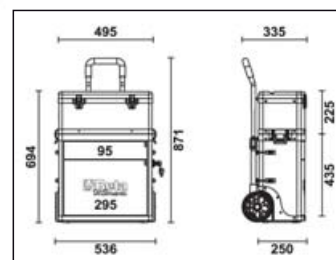
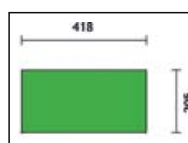

C41H

trolley portautensili
a 2 moduli sovrapponibili

Caratteristiche principali:

- Struttura in lamiera e piani in materiale plastico: grande robustezza e peso ridotto.
- 2 moduli separabili:
 - 1 cestello superiore,
 - 1 modulo con 2 cassetti altezza 95 mm, 1 cassetta estraibile in materiale plastico altezza 66 mm e 1 cassetto altezza 295 mm.
- Ruote di grosso diametro (160 mm), integrate nella struttura per facilitare il trasporto anche su gradini.
- Serratura centralizzata laterale per la chiusura dei cassetti del modulo inferiore.
- Cassetti montati su guide telescopiche a sfera con doppio gancio di chiusura.
- Impugnatura con manico telescopico in alluminio.
- Portaminuterie integrato
- Cassetto inferiore con doppia guida telescopica

- Assortimenti consigliati: 5940/SBK, 5915VU/5 e 5941VU-M
- * Colorazioni disponibili su richiesta

21 kg

		€		
C41H-O	RAL 2011	469,00	1	041000002
C41H-N	RAL 9005	469,00	1	041000005
C41H-B	RAL 5002	469,00	1	041000006
C41H-R	RAL 3000	469,00	1	041000008
C41H-G	RAL 7016	469,00	1	041000010
C41H-Y	RAL 1023	469,00	1	041000012
C41H-W	RAL 9016	469,00	1	041000021
C41H-V	RAL 6016	469,00	1	041000024



C41H-O



C41H-W

C41H-Y

C41H-R

C41H-V

C41H-B

C41H-G

C41H-N

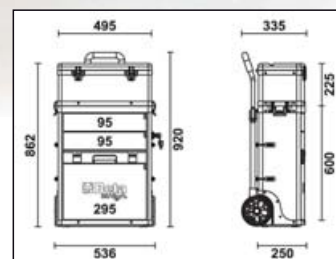
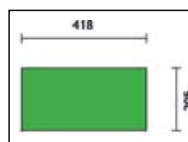

C41MS

modulo superiore con portaminuterie integrato per trolley C41

📦 3 kg

		€	📦	🖨️
C41MS	RAL 2011	108,00	1	041000904
C41MS/N	RAL 9005	108,00	1	041000922
C41MS/B	RAL 5002	108,00	1	041000932
C41MS/R	RAL 3000	108,00	1	041000942
C41MS/G	RAL 7016	108,00	1	041000952
C41MS/Y	RAL 1023	108,00	1	041000962
C41MS/W	RAL 9016	108,00	1	041000972
C41MS/V	RAL 6016	108,00	1	041000982



📏 495x250x225 mm

C41H/CE

cassetta portautensili con separatori estraibili per minuterie, in materiale plastico per trolley C41H

📦 1,3 kg

C41H/CE		€ 28,50	📦 1	🖨️ 041000916
---------	--	---------	-----	--------------



C42H

trolley portautensili a tre moduli sovrapponibili

Caratteristiche principali:

- Struttura in lamiera e materiale plastico: grande robustezza e peso ridotto.
- 3 moduli separabili:
 - 1 cestello superiore, altezza 220 mm
 - 1 modulo portautensili centrale, altezza 180 mm
 - 1 modulo portautensili inferiore con ruote, altezza 330 mm.
- Ruote di grosso diametro (ø 160 mm),
- Manico telescopico regolabile in 3 posizioni.
- Sistema di sgancio rapido dei moduli: agevole e veloce accesso a tutti i diversi scomparti portautensili.
- Cestello superiore con vano portaoggetti interno e 3 portaminuterie integrati nel coperchio
- Predisposizione per essere utilizzato solamente con 2 moduli.
- Assortimenti consigliati: 5940/SBK e 5915VU/5

📦 14 kg

C42H		€ 334,00	📦 1	🖨️ 042000002
------	--	----------	-----	--------------

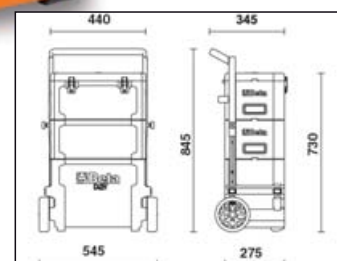

C42 MCH

Modulo centrale aggiuntivo per trolley C42

📦 2,5 kg

C42MCH		€ 64,00	📦 1	🖨️ 042000105
--------	--	---------	-----	--------------



📏 440x180x275 mm

C43

trolley portautensili
a tre moduli sovrapponibili

Caratteristiche principali:

- Struttura in lamiera e materiale plastico
- 3 moduli separabili:
- 1 cestello superiore, altezza 222 mm
- 1 modulo centrale, altezza 168 mm con 2 cassetti altezza 60 mm
- 1 modulo inferiore, altezza 332 mm con sportello basculante altezza 280 mm con ruote
- Ruote \varnothing 128 mm
- Manico telescopico regolabile in 4 posizioni
- Sistema di sgancio dei moduli con accesso a tutti i diversi scomparti portautensili
- Cestello superiore con vassoio portaoggetti interno rimovibile e 2 portaminuterie integrati nel coperchio

15,5 kg

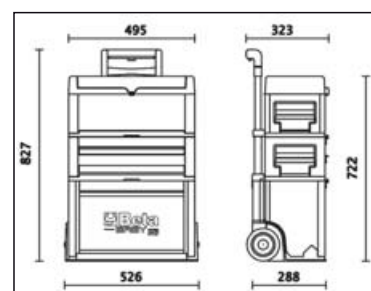

C43

€ 220,00 1 043000003

CX49-G

carrello multifunzione

utilizzabile come postazione mobile
per strumenti di diagnosi, laptop, tester e caricabatterie.

CARATTERISTICHE

- Struttura in lamiera verniciata: massima stabilità e solidità
- Maniglia ergonomica
- Piano di appoggio superiore su 2 livelli
- Cassetto estraibile per mini tastiera
- 2 ripiani centrali con posizione regolabile e 1 ripiano basso fisso
- 4 utili avvolgicavo laterali in plastica
- 2 pratici contenitori laterali
- 2 ruote posteriori fisse Ø 160 mm
- 2 ruote anteriori girevoli Ø 100 mm (una con freno)
- Peso: 43 kg



CX49

€ 570,00



049000102

CA49-G

carrello multifunzione con antenna

utilizzabile come postazione mobile
per strumenti di diagnosi, laptop, tester e caricabatterie.

CARATTERISTICHE

- Struttura in lamiera verniciata: massima stabilità e solidità
- Maniglia ergonomica
- Piano di appoggio superiore su 2 livelli
- Cassetto estraibile per mini tastiera
- 1 ripiano con posizione regolabile, 1 ripiano fisso e antenna di chiusura
- 4 utili avvolgicavo laterali in plastica
- 2 pratici contenitori laterali
- 2 ruote posteriori fisse Ø 160 mm
- 2 ruote anteriori girevoli Ø 100 mm (una con freno)
- Peso: 46,5 kg



CA49 G

€ 640,00



049000112

4900-COVER C49

protezione in nylon per carrello multifunzione C49



4900-COVER C49

€ 27,00



049000930

C51

carrello

- 3 ripiani ricoperti in gomma millerighe antiscivolo
- Maniglia ergonomica
- Doppia possibilità di fissaggio del ripiano centrale
- Quattro ruote Ø 100 mm:
- 2 fisse e 2 girevoli (una con freno).
- Capacità di carico statico: 200 kg. (distribuita sui 3 ripiani)

📦 21 kg

	€	📦	🏠
C51 O	217,00	1	051000001
C51 G	217,00	1	051000002
C51 R	217,00	1	051000003

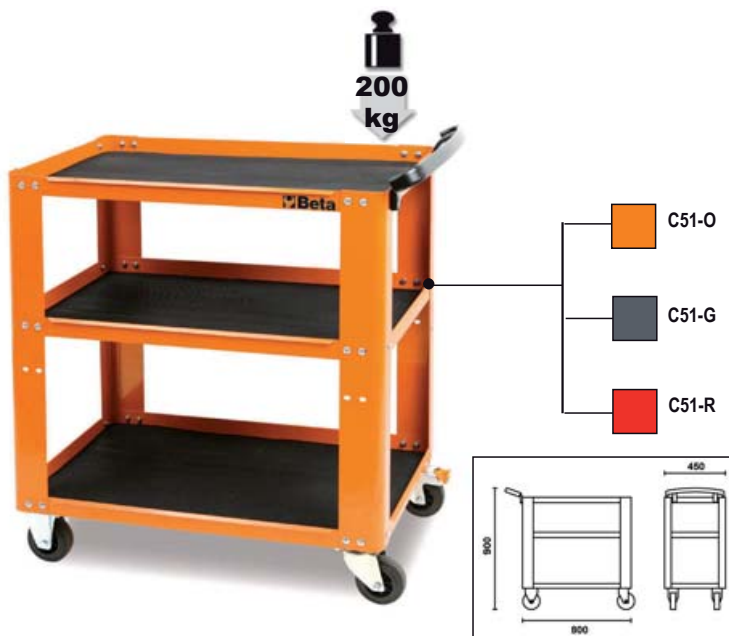

C50S

carrello di servizio con 3 cassetti

Caratteristiche principali:

- Piano di lavoro termoplastico
- 3 cassetti da 588x367 mm, montati su guide telescopiche a sfera, altezza 70 mm
- Piano dei cassetti protetto da tappetini di gomma espansa
- Serratura di sicurezza centralizzata frontale
- Pratico portagiravite laterale incluso
- Due portabombolette laterali integrati nella struttura
- Ampio ripiano inferiore protetto con tappetino in gomma antiolio e antibenzina
- Quattro ruote Ø 125 mm:
- 2 fisse e 2 girevoli (una con freno)
- Capacità di carico statico: 400 kg
- Portata di ogni cassetto: 15 kg uniformemente distribuiti
- Possibilità di applicazione del portacarta 2400S-R/PC
- Possibilità di applicazione della mensola pieghevole 5000MS

📦 38 kg

	€	📦	🏠
C50S-O	430,00	1	050000301
C50S-G	430,00	1	050000302
C50S-R	430,00	1	050000303



5000MS

mensola pieghevole per carrello C50S

- Utilizzabile come piano di lavoro supplementare
- Piano di lavoro mis. 390x440 mm, protetto con tappetino in gomma antiolio e antibenzina
- Capacità di carico: 20 kg

📦 3,4 kg

	€	📦	🏠
5000MS	49,50	1	050000901

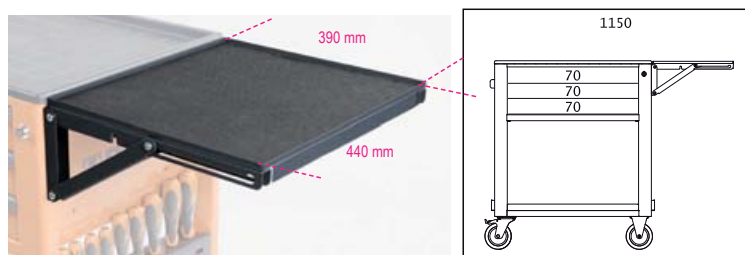

CP51

carrello ad alta resistenza

- 2 ripiani ricoperti da tappetini in gomma
- Maniglia ergonomica
- Quattro ruote Ø 125 mm ad alta resistenza: 2 fisse e 2 girevoli con freno
- Capacità di carico statico: 750 kg. (distribuita sui 2 ripiani)

37 kg

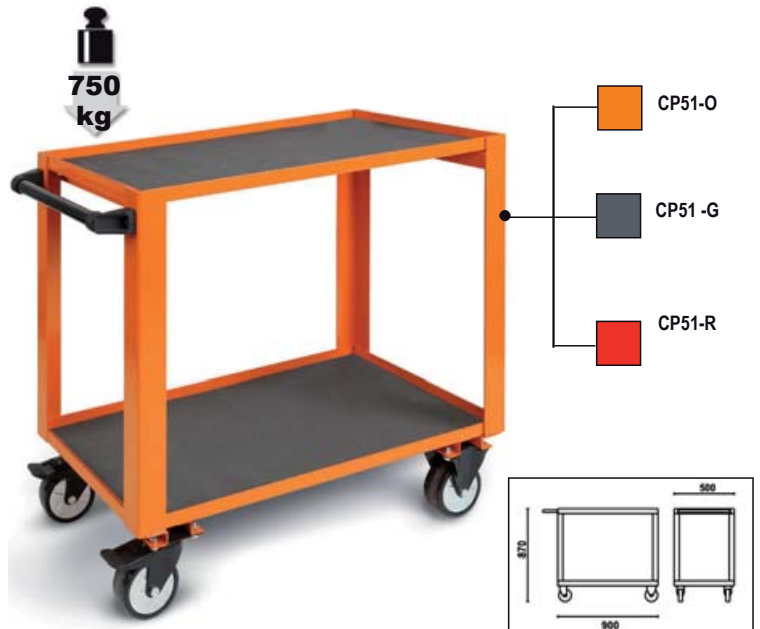

CP51 O	€ 285,00	1	051000501
CP51 G	€ 285,00	1	051000502
CP51 R	€ 285,00	1	051000503

CB52

carrello per cambi/trasmissioni con recupero liquidi

Il piano inclinato e i fori di scolo permettono il recupero dei liquidi direttamente nella vaschetta di raccolta

Dotato di:

- 4 ruote girevoli di cui 2 con freno
- cassetto per utensili
- vaschetta di raccolta liquidi estraibile con capacità 7 litri
- 2 ripiani

60 kg



CB52	€ 540,00	1	052000201
------	----------	---	-----------



C56P O

banco da lavoro pieghevole

Compatto e facilmente trasportabile.
Piano di lavoro 800x500mm (spessore 30 mm) in MDF e lamiera zincata, utilizzabile da entrambi i lati.
Maniglia con protezione in gomma per un agevole trasporto.
Piedini con copertura anti-scivolamento.
Capacità di carico statico: 250 kg

📦 25 kg

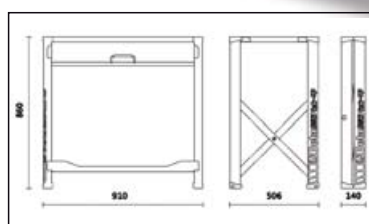

C56P O

€ 345,00 1 056000011

C56PL O

banco da lavoro pieghevole, versione Light

Leggero, compatto e facilmente trasportabile.
Piano di lavoro 800x500mm in lamiera zincata utilizzabile da un solo lato, protetto con rivestimento in gomma antiolio e antibenzina.
Maniglia con protezione in gomma per un agevole trasporto.
Piedini con copertura anti-scivolamento.
Capacità di carico statico: 200 kg

📦 18,5 kg

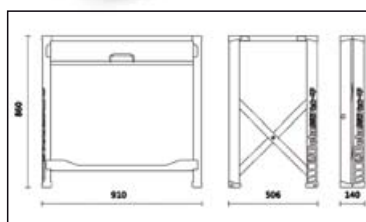

C56PL O

€ 299,00 1 056000021

C54S

armadietti Cargo

Sono realizzati sulla base di accurate ricerche presso qualificati utilizzatori professionali ed offrono le soluzioni ideali per operare in modo confortevole e razionale.

L'apertura dei pannelli forati delle due antine permette lo sfruttamento anche della loro superficie interna.

Caratteristiche principali:

- 1 cassetto montato su guide telescopiche.
- Possibilità di modificare facilmente la disposizione degli utensili in funzione delle proprie esigenze.
- Posizionamento a parete per mezzo di due asole situate posteriormente.
- Serratura per chiusura contemporanea di antine e cassetto.
- Termoformato vuoto per bussole e accessori da 1/2".



C54S-G



C54S-R



C54S-O

37 kg

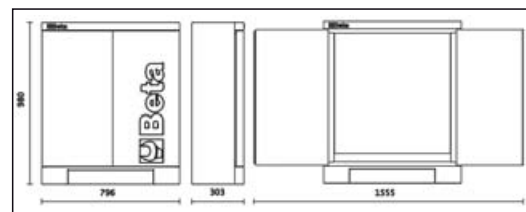
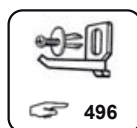

C54S-O	€ 549,00	1	054000301
C54S-G	€ 549,00	1	054000302
C54S-R	€ 549,00	1	054000303

Beta

C57SA

banco da lavoro MasterCargo

- Modello con parete portautensili (C57SP) e una cassettera.

Cassettera formata da cinque cassetti da 367x588 mm di cui 3 altezza 90 mm, 1 altezza 180 mm e 1 altezza 280 mm montati su guide telescopiche a sfera.

Predisposizione per l'inserimento di termoformati
Serratura centralizzata.

Parete portautensili anche appendibile mediante asole.

Tapparella in alluminio, manovrabile verticalmente, con serratura.

Tre pannelli forati amovibili per il sostegno degli utensili.

Piano di lavoro in legno multistrato, rivestito in laminato plastico con tre fori per la collocazione di una morsa 1599F/150 da ordinare separatamente.

📦 205 kg



1800 kg

C57SA O



C57SA G



C57SA R



5700S A O

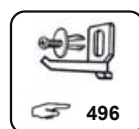

h	max
90 mm	30 kg
180 mm	40 kg
280 mm	40 kg

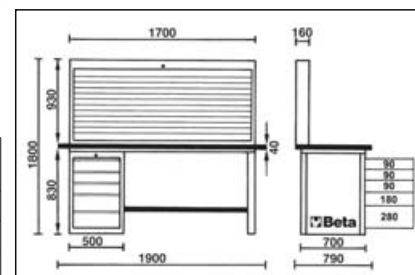

	€	📦	🏠
C57SA-O	3.720,00	1	057001005
C57SA-G	3.720,00	1	057001205
C57SA-R	3.720,00	1	057001405

C57SD

banco da lavoro MasteraCargo

- Modello con una cassettera

Cassettera formata da cinque cassetti da 367x588 mm di cui 3 altezza 90 mm, 1 altezza 180 mm e 1 altezza 280 mm montati

su guide telescopiche a sfera.

Predisposizione per l'inserimento di termoformati
Serratura centralizzata.

Piano di lavoro in legno multistrato, rivestito in laminato plastico con tre fori per la collocazione di una morsa 1599F/150 da ordinare separatamente.

📦 158 kg



1800 kg

C57SD O



h	max
90 mm	30 kg
180 mm	40 kg
280 mm	40 kg



C57SD G



C57SD R

	€	📦	🏠
C57SD-O	2.650,00	1	057001004
C57SD-G	2.650,00	1	057001204
C57SD-R	2.650,00	1	057001404

C57SB

banco da lavoro MasterCargo

- Modello con parete portautensili (C57SP) e due cassettiere.

Cassettiera formata da cinque cassetti da 367x588 mm di cui 3 altezza 90 mm, 1 altezza 180 mm e 1 altezza 280 mm montati su guide telescopiche a sfera.

Predisposizione per l'inserimento di termoformati Serratura centralizzata.

Parete portautensili anche appendibile mediante asole.

Tapparella in alluminio, manovrabile verticalmente, con serratura.

Tre pannelli forati amovibili per il sostegno degli utensili.

Piano di lavoro in legno multistrato, rivestito in laminato plastico con tre fori per la collocazione di una morsa 1599F/150 da ordinare separatamente.

1800 kg



C57S B O

243 kg



C57S B G



C57S B R



5700S B O



h	max
90 mm	30 kg
180 mm	40 kg
280 mm	40 kg

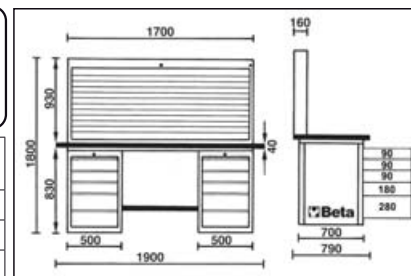

	€		
C57S/B-O	4.640,00	1	057001006
C57S/B-G	4.640,00	1	057001206
C57S/B-R	4.640,00	1	057001406

C57SC

banco da lavoro MasterCargo

- Modello con due cassettiere.

Cassettiera formata da cinque cassetti da 367x588 mm di cui 3 altezza 90 mm, 1 altezza 180 mm e 1 altezza 280 mm montati su guide telescopiche a sfera.

Predisposizione per l'inserimento di termoformati Serratura centralizzata.

Piano di lavoro in legno multistrato, rivestito in laminato plastico con tre fori per la collocazione di una morsa 1599F/150 da ordinare separatamente.

1800 kg



C57SC O

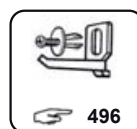

h	max
90 mm	30 kg
180 mm	40 kg
280 mm	40 kg



C57SC G



C57SC R

196 kg

	€		
C57S/C-O	3.570,00	1	057001003
C57S/C-G	3.570,00	1	057001203
C57S/C-R	3.570,00	1	057001403

C57SP

parete portautensili MasterCargo

- Parete portautensili anche appendibile mediante asole.
- Tapparella in alluminio, manovrabile verticalmente, con serratura.
- Tre pannelli forati amovibili per il sostegno degli utensili.

46 kg

	€		
C57SP-O	1.075,00	1	057001020
C57SP-G	1.075,00	1	057001220
C57SP-R	1.075,00	1	057001420



C57SP O

1700 mm

930 mm

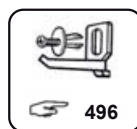

496



C57SP G



C57SP R

5700LAMP

lampada per banco MasterCargo

- Robusta struttura in lamiera composta da quattro elementi; completa di viti per l'assemblaggio.
- Portalampana con striscia LED da 1120 Lumen, 4000K, 14W
- Alimentazione 230V.
- Fornito senza cavo.

9 kg

	€		
5700 LAMP	250,00	1	057000005



5700LAMP + 5700SA O

C58P

parete portautensili

- Soluzione con chiusura a tapparella in alluminio verniciato e serratura di chiusura.
- Due pannelli forati amovibili per il sostegno degli utensili.

31 kg

	€		
C58P-O	800,00	1	058000121
C58P-G	800,00	1	058000122
C58P-R	800,00	1	058000123



C58P G



C58P R

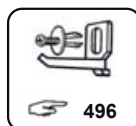

496



C58P O

1200 mm

930 mm

PV

pannello portautensili da parete

	LxA mm	kg	€		
PV1	1000x920	10,2	144,00	1	088880010
PV1,5	1500x920	14,2	190,00	1	088880015

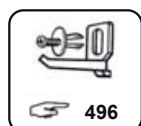

496



C56W

banco da lavoro con piano di lavoro in legno

- Piano di lavoro in legno multistrato con fori per la collocazione di una morsa 1599F/125 (da ordinare separatamente)
- Struttura in acciaio con 6 gambe di sostegno
- Capacità di carico statico: 1.200 kg
- Abbinabile alla parete C57SP (non fissabile al piano di lavoro).
- Due cassetti dotati di serratura.
- Predisposizione per il fissaggio al pavimento.

📦 86 kg

C56W-O	920,00	1	056000251
C56W-G	920,00	1	056000252
C56W-R	920,00	1	056000253



C56B

banco da lavoro con piano in legno

Caratteristiche principali:

- Piano di lavoro in legno multistrato con fori per la collocazione di una morsa 1599F/125 (da ordinare separatamente).
- Struttura in acciaio con 4 gambe di sostegno
- Capacità di carico statico: 600 kg.
- Ripiano inferiore portaoggetti con capacità di carico 150 kg. (uniformemente distribuiti)
- Predisposizione per il fissaggio al pavimento

📦 54,5 kg

C56B-O	515,00	1	056000401
C56B-G	515,00	1	056000402
C56B-R	515,00	1	056000403



C56

banco da lavoro

- Piano di lavoro in lamiera verniciata con bordo perimetrale
- Struttura in acciaio con 6 gambe di sostegno
- Capacità di carico statico: 1.200 kg
- Abbinabile alla parete C57SP non fissabile al piano di lavoro.
- Due cassetti dotati di serratura.
- Predisposizione per il fissaggio al pavimento.

📦 82 kg

C56-O	775,00	1	056000201
C56-G	775,00	1	056000202
C56-R	775,00	1	056000203



C56M

banco da lavoro

- Piano di lavoro in metallo rivestito per metà da lastra in alluminio antiscivolo e per metà da tappeto in gomma asportabile.
- Sottopiano in massello di legno.
- Capacità di carico statico: 800 kg
- Abbinabile alla parete C57SP non fissabile al piano di lavoro.
- Tre cassetti dotati di serratura.
- Predisposizione per il fissaggio al pavimento.

📦 95 kg

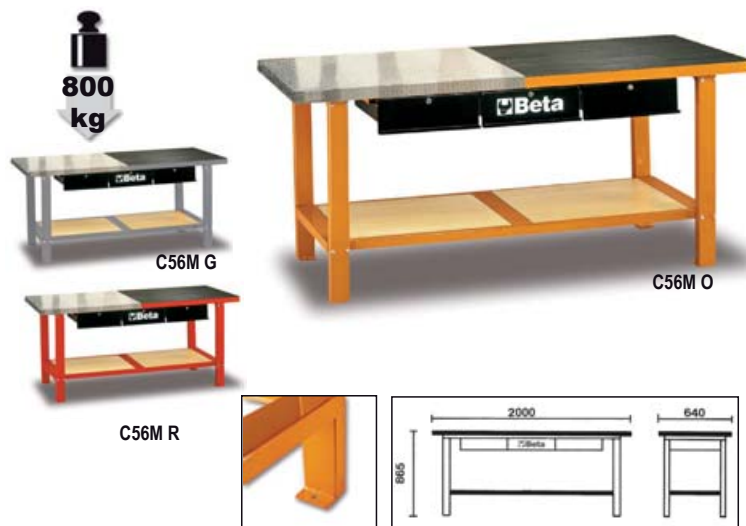

	€	📦	🏠
C56M O	1.120,00	1	056000050
C56M G	1.120,00	1	056000053
C56M R	1.120,00	1	056000054

C58B

banco da lavoro con piano in legno

Caratteristiche principali:

- Piano di lavoro in legno multistrato con fori per la collocazione di una morsa 1599F/125 (da ordinare separatamente).
- Struttura in acciaio con 4 gambe di sostegno
- Capacità di carico statico: 800 kg.
- Ripiano inferiore portaoggetti con capacità di carico 150 kg. (uniformemente distribuiti)
- Predisposizione per il fissaggio al pavimento

📦 44 kg



	€	📦	🏠
C58B-O	470,00	1	058000401
C58B-G	470,00	1	058000402
C58B-R	470,00	1	058000403

C58M

banco da lavoro

- Piano di lavoro in metallo interamente rivestito da un tappetino in gomma antiscivolo asportabile.
- Sottopiano in massello di legno.
- Capacità di carico statico: 800 kg.
- Abbinabile alla parete C58P non fissabile al piano di lavoro.
- 2 cassetti dotati di serratura.
- Predisposizione per il fissaggio al pavimento.
- Possibilità di applicazione opzionale del piano di lavoro in alluminio C58M/PA.

📦 65 kg



	€	📦	🏠
C58M-O	720,00	1	058000300
C58M-G	720,00	1	058000302
C58M-R	720,00	1	058000303

C58M/PA

piano in alluminio godronato
per banco da lavoro C58M

4,5 kg



C58M/PA

€ 285,00 1 058000350

C59A

banco da lavoro "Endurance" con 1 cassetiera da 6 cassetti

Caratteristiche principali:

- Ripiano in legno multistrato con fori per la collocazione di una morsa 1599F/125 (da ordinare separatamente).
- 6 cassetti 588x367 mm, montati su guide telescopiche a sfera:
 - 4 cassetti altezza 70 mm
 - 1 cassetto altezza 140 mm
 - 1 cassetto altezza 280 mm
- Piano dei cassetti protetto da tappetini di gomma espansa.
- Frontalino dei cassetti in Nylon ad alta resistenza.
- Cassettiere predisposte per l'inserimento di termoformati.
- Serratura di sicurezza centralizzata frontale.
- Ripiano inferiore portaoggetti.
- predisposizione per portacarta (2400S-R/PC) e portaflaconi (2400S/PF) da ordinare separatamente.

115 kg



C59A O



C59A G



C59A R



1500 kg

h	max
70 mm	25 kg
140 mm	30 kg
280 mm	35 kg

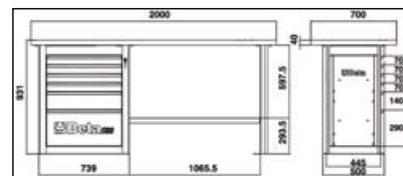

C59A-O	€ 1.360,00	1	059000001
C59A-G	€ 1.360,00	1	059000021
C59A-R	€ 1.360,00	1	059000041

Beta

C59B

banco da lavoro "Endurance" con 2 cassettiere da 6 cassetti

Caratteristiche principali:

- Ripiano in legno multistrato con fori per la collocazione di una morsa 1599F/125 (da ordinare separatamente).
- 12 cassetti 588x367 mm, montati su guide telescopiche a sfera:
 - 8 cassetti altezza 70 mm
 - 2 cassetti altezza 140 mm
 - 2 cassetti altezza 280 mm
- Piano dei cassetti protetto da tappetini di gomma espansa.
- Possibilità di inserimento termoformati.
- Serratura di sicurezza centralizzata frontale.
- Ripiano inferiore portaoggetti.
- predisposizione per portacarta (2400S-R/PC) e portafilaconi (2400S/PF) da ordinare separatamente.

155 kg

	€		
C59B-O	1.810,00	1	059000002
C59B-G	1.810,00	1	059000022
C59B-R	1.810,00	1	059000042

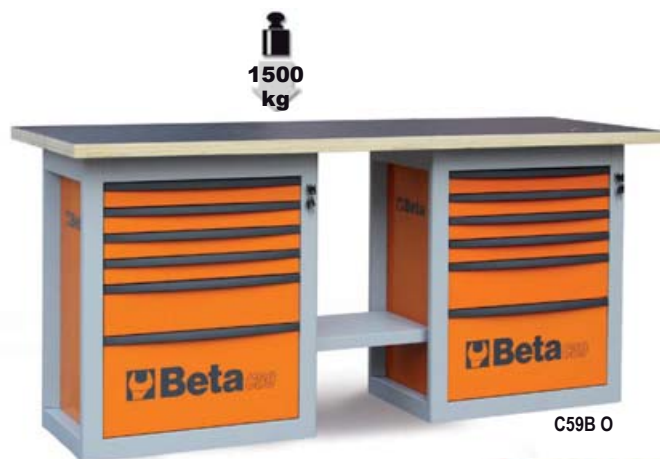

C59B O



C59B G



C59B R

h	max
70 mm	25 kg
140 mm	30 kg
280 mm	35 kg

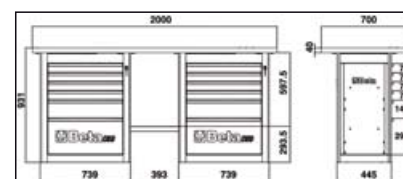

C59C

banco da lavoro "Endurance" con 1 cassetiera da 6 cassetti, modello corto

Caratteristiche principali:

- Ripiano in legno multistrato con fori per la collocazione di una morsa 1599F/125 (da ordinare separatamente).
- 6 cassetti 588x367 mm, montati su guide telescopiche a sfera:
 - 4 cassetti altezza 70 mm
 - 1 cassetto altezza 140 mm
 - 1 cassetto altezza 280 mm
- Piano dei cassetti protetto da tappetini di gomma espansa.
- Possibilità di inserimento termoformati.
- Serratura di sicurezza centralizzata frontale.
- Ripiano inferiore portaoggetti.
- predisposizione per portacarta (2400S-R/PC) e portafilaconi (2400S/PF) da ordinare separatamente.

105 kg

	€		
C59C-O	1.230,00	1	059000003
C59C-G	1.230,00	1	059000023
C59C-R	1.230,00	1	059000043



C59C G



C59C R



C59C O



h	max
70 mm	25 kg
140 mm	30 kg
280 mm	35 kg

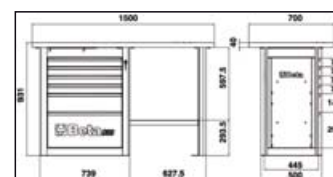

9562T2

tappeto per banco da lavoro 200x160 cm

- protegge il suolo da perdite d'olio, benzina e rispetta l'ambiente
- facile da pulire, fondo gommato ed antiscivolo



	€		
9562T2	192,00	1	095620200



ARREDO OFFICINA



Beta Utensili, per rispondere alle esigenze di un mercato che sempre più ricerca qualità, design e personalizzazione, ha creato "Racing System C55": un arredo per officina modulare che vi offre la possibilità di creare un ambiente di lavoro moderno, modellato sulle vostre necessità.

Qualità

La migliore qualità Beta "Made in Italy" per arredare la tua officina

Organizzazione

Una postazione organizzata in maniera razionale consente di ottimizzare il lavoro



Modularità

Officina componibile in base ai vostri spazi e alle vostre esigenze

Design

Finiture ricercate ed accattivanti per rendere il posto di lavoro un ambiente ordinato e gradevole





MADE IN ITALY

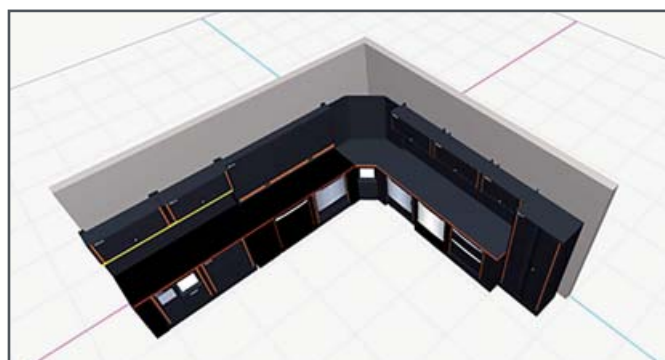

Configura on-line la tua officina
Vai su **www.rsc55.com**



L'officina con i tuoi colori!

RSC55 ti offre la possibilità di ordinare i banchi e la parete con tapparella in versione neutra (grigia) e di completare la tua personalizzazione con gli inserti colorati verticali da ordinare tra 7 differenti nastri adesivi

1. Ordina i tuoi moduli con colorazione neutra

2. Ordina l'inserto verticale

Scegli il colore secondo i tuoi gusti o in base ai colori sociali della tua azienda

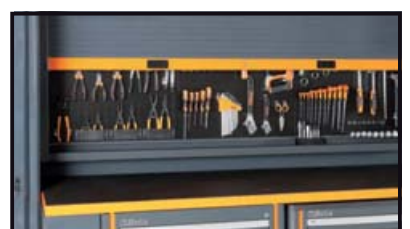

Combinazione completa composta da:

- Armadio ad 1 anta (C55A1)
- Armadio a 2 ante (C55A2)
- Banco da lavoro (C55BO/2)
- Banco da lavoro con prese (C55PRO BO/2)
- Cassettiera mobile con 7 cassetti (C55C7)
- Modulo fisso con 2 cassettoni (C55M2)
- Modulo fisso con 7 cassetti (C55M7)
- Modulo fisso di servizio (C55MS)
- Parete con pensili (C55/2PM)
- Parete portautensili con tapparella (C55PS-O)

C55AB

combinazione arredo officina

Combinazione composta da:

- Armadio a 2 ante (C55A2)
- Banco da lavoro (C55BO/2)
- Modulo fisso con 7 cassetti (C55M7)
- Modulo fisso di servizio (C55MS)
- Parete con pensili (C55/2PM)

407 kg



C55AB

€ 6.900,00 1 055000020



C55PB/3

combinazione arredo officina

Combinazione composta da:

- Banco da lavoro (C55BO/2)
- Cassettiera mobile con 8 cassetti (C55C8)
- Modulo fisso con 2 cassettoni (C55M2)
- Parete portautensili con tapparella (C55PS-O)

334 kg



C55PB/3

€ 5.810,00 1 055000035



C55B/2

banco da lavoro da 2 metri per arredo officina

Con piano da lavoro 2050x700 mm rivestito da uno strato di PVC antiurto e antigraffio resistente agli idrocarburi

- Fori per la collocazione di una morsa 1599F/150 (da ordinare separatamente)
- Piedini regolabili in altezza

📦 105 kg

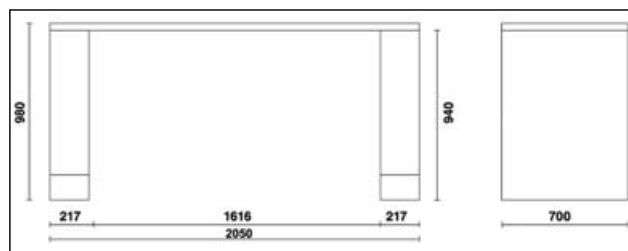

C55BO/2	1.600,00 €	1	055000101
C55BG/2	1.600,00 €	1	055000111

C55PRO B/2

banco da lavoro da 2 metri per arredo officina

Con piano da lavoro 2050x700 mm rivestito da uno strato di PVC antiurto e antigraffio resistente agli idrocarburi

Prese elettriche e arrotolatore integrati:

- Presa Schuko+16+10A
- Presa EU Plug 10A
- Presa per aria compressa con arrotolatore da Ø 8 mm Art. 1901BM/8, lunghezza tubo: 10 m.
- Fori per la collocazione di una morsa Art. 1599F/150 (da ordinare separatamente)
- Piedini regolabili in altezza

📦 110 kg

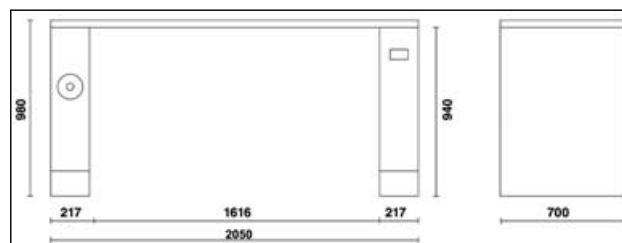
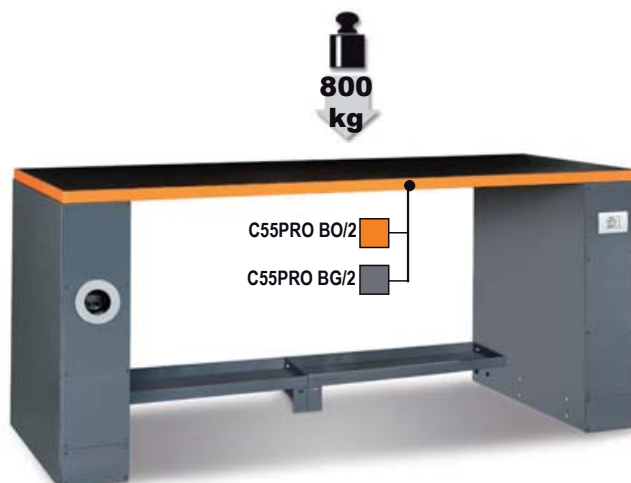

C55PRO BO/2	2.070,00 €	1	055000151
C55PRO BG/2	2.070,00 €	1	055000171

C55B/2,8

banco da lavoro da 2,8 metri per arredo officina

Con piano da lavoro 2850x700 mm rivestito da uno strato di PVC antiurto e antigraffio resistente agli idrocarburi

- Fori per la collocazione di una morsa 1599F/150 (da ordinare separatamente)
- Piedini regolabili in altezza

129 kg

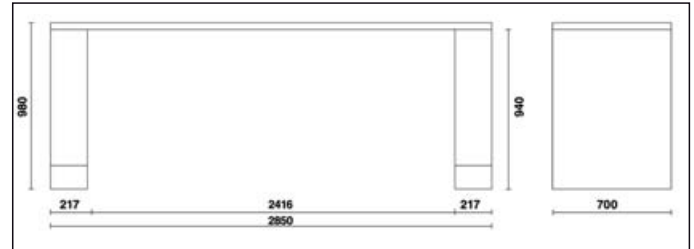
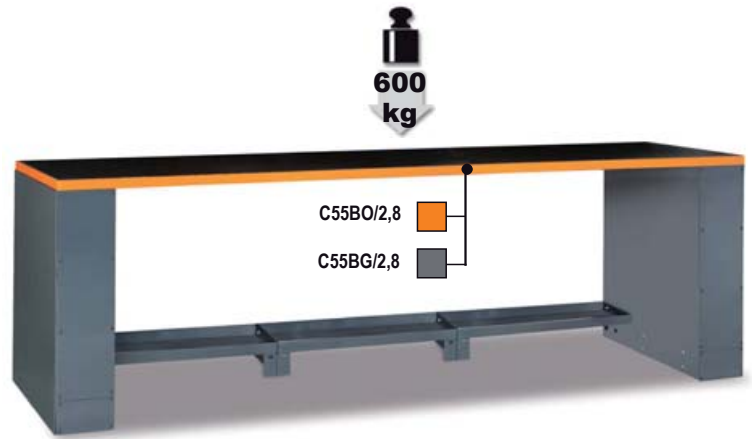

C55BO/2,8	€ 2.010,00	1	055000261
C55BG/2,8	€ 2.010,00	1	055000281

C55PRO B/2,8

banco da lavoro da 2,8 metri per arredo officina

Con piano da lavoro 2850x700 mm rivestito da uno strato di PVC antiurto e antigraffio resistente agli idrocarburi

Prese elettriche e arrotolatore integrati:

- Presa Schuko+16+10A
- Presa EU Plug 10A
- Presa per aria compressa con arrotolatore da Ø 8 mm Art. 1901BM/8, lunghezza tubo: 10 m.
- Fori per la collocazione di una morsa Art. 1599F/150 (da ordinare separatamente)
- Piedini regolabili in altezza

134 kg

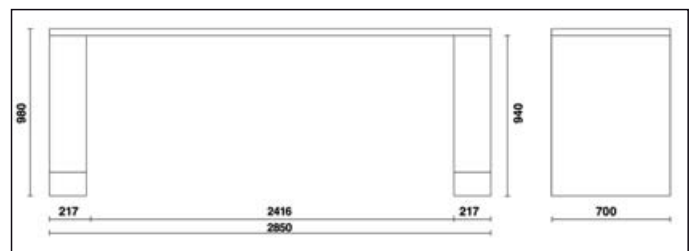
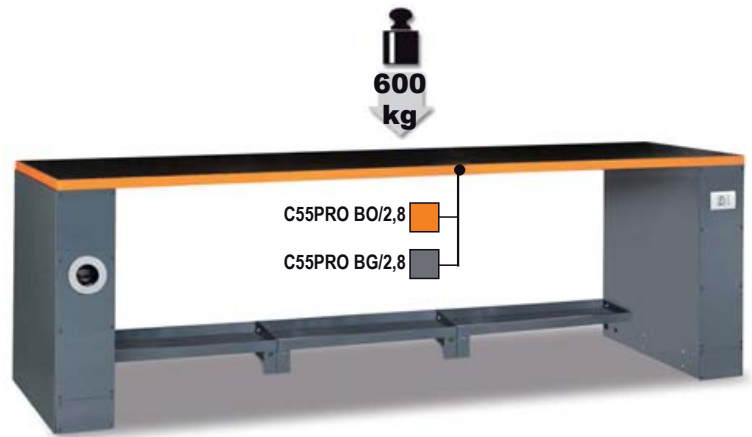

C55PRO BO/2,8	€ 2.480,00	1	055000271
C55PRO BG/2,8	€ 2.480,00	1	055000283

C55B-D4

banco da lavoro doppio da 4 metri con gamba centrale

Con piano da lavoro 4100x700 mm rivestito da uno strato di PVC antiurto e antigraffio resistente agli idrocarburi

- Fori per la collocazione di una morsa 1599F/150 (da ordinare separatamente)
- Piedini regolabili in altezza
- Gamba doppia centrale con vano-portaoggetti e sportello di chiusura 365x750 mm

185 kg

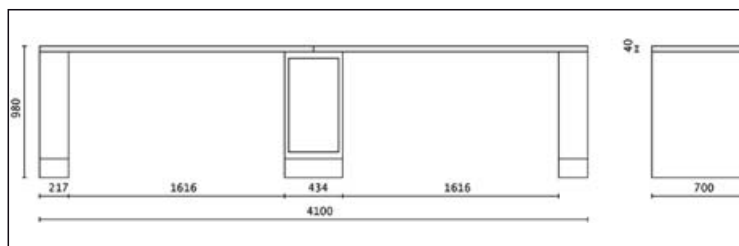

C55BO-D4	€ 3.260,00	1	055000109
C55BG-D4	€ 3.260,00	1	055000119

C55PRO B-D4

banco da lavoro doppio da 4 metri con gamba centrale

Con piano da lavoro 4100x700 mm rivestito da uno strato di PVC antiurto e antigraffio resistente agli idrocarburi

Prese elettriche e arrotolatore integrati:

- Presa Schuko+16+10A
- Presa EU Plug 10A
- Presa per aria compressa con arrotolatore da Ø 8 mm Art. 1901BM/8, lunghezza cavo: 10 m.
- Fori per la collocazione di una morsa Art. 1599F/150 (da ordinare separatamente)
- Piedini regolabili in altezza
- Gamba doppia centrale con vano-portaoggetti e sportello di chiusura 365x750 mm

190 kg

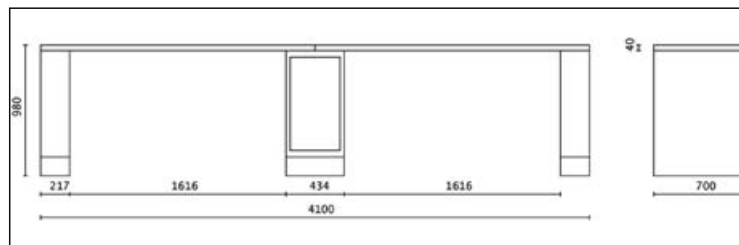
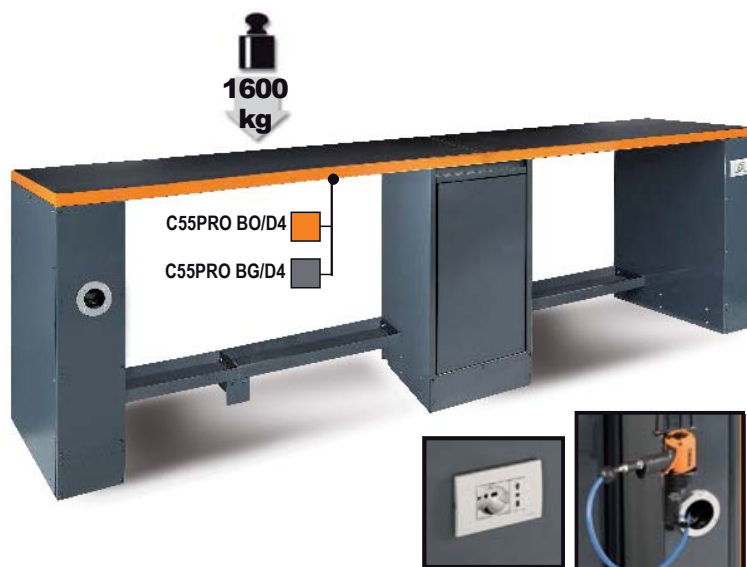

C55PRO-BO-D4	€ 3.730,00	1	055000159
C55PRO-BG-D4	€ 3.730,00	1	055000179

Beta

C55B/G

gamba universale per banco da lavoro arredo officina

- Dotata di piedini regolabili in altezza
- Accesso frontale e laterale
- Utilizzabile per entrambi i lati del banco di lavoro

📦 30 kg

C55B/G € 430,00 1 055000096

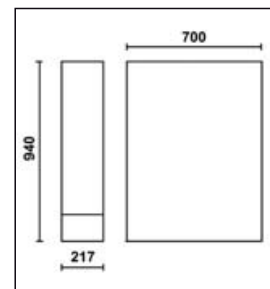

C55B/GAA

gamba universale per banco da lavoro con avvolgitubo integrato

- Avvolgitubo automatico integrato per aria compressa o acqua fredda da Ø 8 mm art 1901BM/8
- Lunghezza tubo: 10 m
- Dotata di piedini regolabili in altezza
- Accesso frontale e laterale

📦 35 kg

C55B/GAA € 799,00 1 055000099

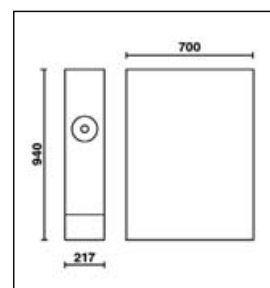
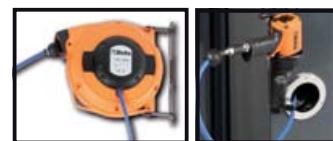

C55B/GDP

gamba doppia per banchi di lavoro adiacenti per arredo officina

- Vano portacarta per rotoli preforati
- Vano portaoggetti con antina
- Dotata di piedini regolabili in altezza

📦 45 kg

C55B/GDP € 1.020,00 1 055000292

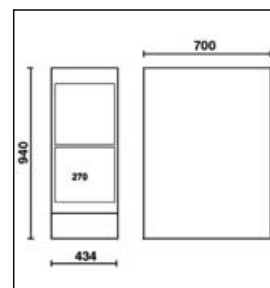

C55B/GDS

gamba doppia per banchi di lavoro adiacenti per arredo officina

- Vano porta-oggetti con sportello 365x750 mm
- Dotata di piedini regolabili in altezza

📦 45 kg

C55B/GDS € 920,00 1 055000291

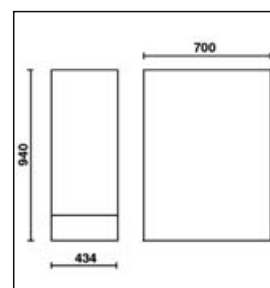

C55B/GE

gamba universale con prese elettriche per banco da lavoro arredo ufficio

- Presa Schuko+16+10A
- Presa EU Plug 10A
- Dotata di piedini regolabili in altezza
- Accesso frontale e laterale

30 kg

C55B/GE € 530,00 1 055000097

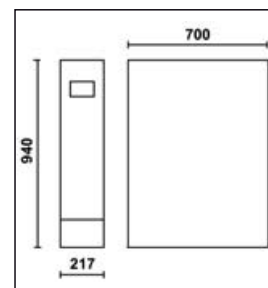

C55B/GAE

gamba universale con avvolgitore elettrico integrato per banco da lavoro arredo ufficio

- Avvolgitore automatico integrato con presa Schuko art. 1848.
- Lunghezza cavo: 15 m
- Con protezione termica
- Dotata di piedini regolabili in altezza
- Accesso frontale e laterale

35 kg

C55B/GAE € 872,00 1 055000094

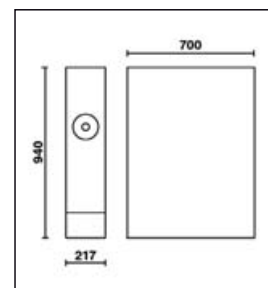

 **Beta**

C55/PL-1,024

piano di lavoro da 1 metro per estensione banco

Piano di lavoro in lamiera verniciata 1024x700 mm rivestito da uno strato di PVC antiurto e antigraffio resistente agli idrocarburi

21 kg

C55/PLO-1,024	€ 355,00	1	055000130
C55/PLG-1,024	€ 355,00	1	055000131



C55B PT/2

piano di lavoro da 2 metri per banco arredo officina

Piano di lavoro in lamiera verniciata 2050x700 mm rivestito da uno strato di PVC antiurto e antigraffio resistente agli idrocarburi
Fori per la collocazione di una morsa 1599F/150 da ordinare separatamente

43 kg

C55B PT/2	€ 740,00	1	055000106
C55BG PT/2	€ 740,00	1	055000116



C55B PT/2,8

piano di lavoro da 2,8 metri per banco arredo officina

Piano di lavoro in lamiera verniciata 2850x700 mm rivestito da uno strato di PVC antiurto e antigraffio resistente agli idrocarburi
Fori per la collocazione di una morsa 1599F/150 da ordinare separatamente

61 kg

C55BO PT/2,8	€ 1.150,00	1	055000266
C55BG PT/2,8	€ 1.150,00	1	055000286



C55RB

rivestimento in PVC antiurto antigraffio resistente agli idrocarburi

per proteggere il piano di lavoro.

- C55RB/2: per banco da 2 metri
- C55RB/2,8: per banco da 2,8 metri
- C55RB/0,7: per banco da 700x700mm
- C55RB/1: per banco da 1 metro

C55RB/2	€ 125,00	1	055000195
C55RB/2,8	€ 170,00	1	055000196
C55RB/0,7	€ 70,00	1	055000199
C55RB/1	€ 95,00	1	055000198



C55B/VS

staffa inferiore sostegno banchi

Misure 800x230x60 mm

4 kg

C55B/VS	€ 95,00	1	055000095
---------	---------	---	-----------



C55C7

cassettiera mobile con 7 cassetti per arredo officina

7 cassetti da 588x367 mm, montati su guide telescopiche a sfera

- 4 ruote Ø 100 mm, 2 fisse e 2 girevoli (una con freno)
- Sistema di apertura in alluminio posizionato su tutta la lunghezza del cassetto
- Piano dei cassetti protetto da tappetini di gomma espansa
- Serratura centralizzata frontale
- Predisposizione per l'inserimento dei termoformati

79 kg

1000
kg



h	max
70 mm	30 kg
245 mm	40 kg

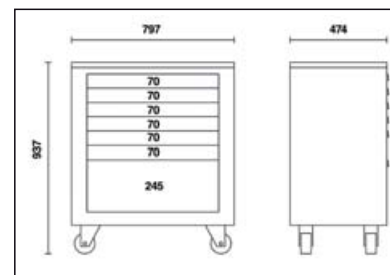
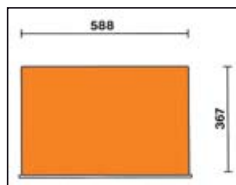

C55C7

€ 1.480,00 1 055000201

Beta

C55C8

modulo cassetiera mobile con 8 cassetti per arredo officina

8 cassetti da 588x367 mm, montati su guide telescopiche a sfera

- 4 ruote Ø 100 mm, 2 fisse e 2 girevoli (una con freno)
- Sistema di apertura in alluminio posizionato su tutta la lunghezza del cassetto
- Piano dei cassetti protetto da tappetini di gomma espansa
- Serratura centralizzata frontale
- Predisposizione per l'inserimento dei termoformati

81 kg



h	max
70 mm	30 kg
175 mm	40 kg

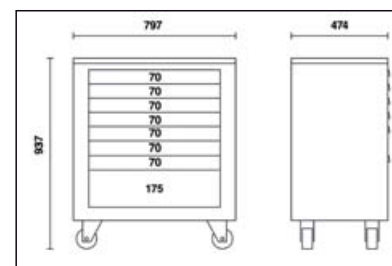
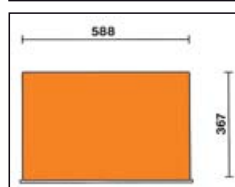

C55C8

€ 1.510,00 1 055000206

C55M2

modulo fisso con 2 cassetti per arredo officina

2 cassetti da 588x367mm, montati su guide telescopiche a sfera

- Sistema di apertura in alluminio posizionato su tutta la lunghezza del cassetto
- Piano dei cassetti protetto da tappetini di gomma espansa
- Serratura centralizzata frontale

66 kg



h	max
280 mm	40 kg
385 mm	40 kg

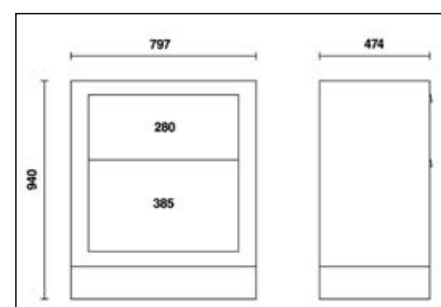
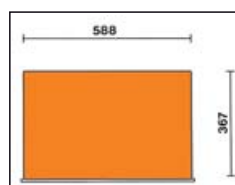

C55 M2

€ 1.260,00 1 055000202

C55M4

modulo fisso con 4 cassetti per arredo officina

4 cassetti da 588x367 mm, montati su guide telescopiche a sfera

- Sistema di apertura in alluminio posizionato su tutta la lunghezza del cassetto
- Piano dei cassetti protetto da tappetini di gomma espansa
- Serratura centralizzata frontale

75 kg



h	max
140 mm	30 kg
245 mm	40 kg

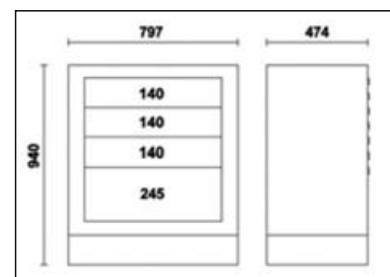
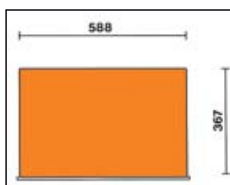

C55M4

€ 1.320,00



1



055000212

C55M7

modulo fisso con 7 cassetti per arredo officina

7 cassetti da 588x367 mm, montati su guide telescopiche asfera

- Sistema di apertura in alluminio posizionato su tutta la lunghezza del cassetto
- Piano dei cassetti protetto da tappetini digomma espansa
- Serratura centralizzata frontale
- Predisposizione per l'inserimento dei termoformati

78 kg



h	max
70 mm	30 kg
245 mm	40 kg

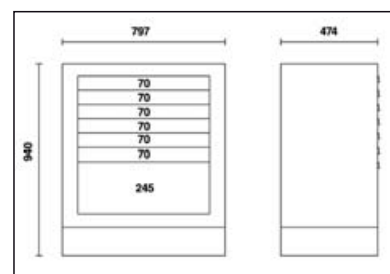
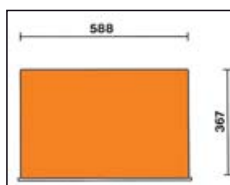

C55M7

€ 1.400,00



1



055000203

C55M8

modulo fisso con 8 cassetti per arredo officina

8 cassetti da 588x367 mm, montati su guide telescopiche asfera

- Sistema di apertura in alluminio posizionato su tutta la lunghezza del cassetto
- Piano dei cassetti protetto da tappetini digomma espansa
- Serratura centralizzata frontale
- Predisposizione per l'inserimento dei termoformati

📦 78,9 kg



h	max
70 mm	30 kg
175 mm	40 kg

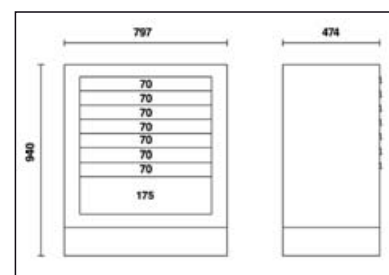
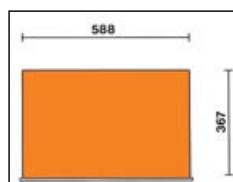

C55M8

€ 1.430,00 1 055000207

C55CS

Modulo fisso per rifiuti differenziati per arredo officina

- Vano spazzatura estraibile 588x465 mm montato su guide telescopiche a sfera
- 2 capienti contenitori interni estraibili per differenziare i rifiuti

📦 62 kg

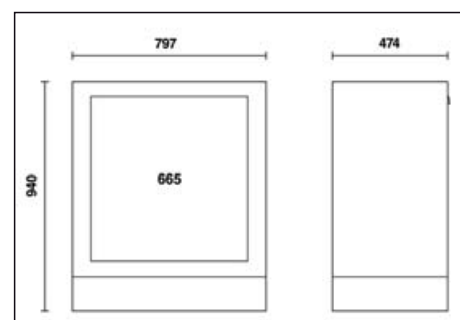

C55CS

€ 1.280,00 1 055000208

C55MA

modulo fisso con due antine per arredo officina

- Sistema di apertura push & pull a pressione
- Dotato di serratura
- Ripiano interno regolabile in altezza

📦 75 kg

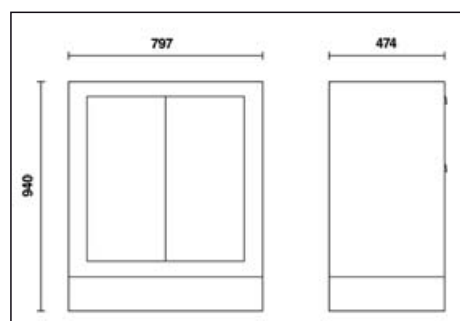

C55 MA

€ 1.090,00 1 055000205

C55MDO

Modulo fisso di distribuzione olio per arredo officina

- 2 arrotolatori con tubo flessibile da 7m - 1/2" inclusi
- Completo di 2 pistole con conta litri digitali dotate di salvagoccia automatico.
 - portata max: 35 l/min
 - viscosità: 8÷5000 mPas

📦 94 kg

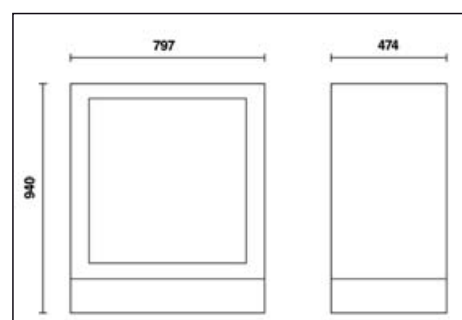

C55MDO

€ 2.770,00 1 055000210

C55MS

modulo fisso di servizio per arredo officina

- Cestino portarifiuti integrato
- Vano portacarta per rotoli preforati
- Cassettone portaoggetti 305x270 mm

📦 75 kg

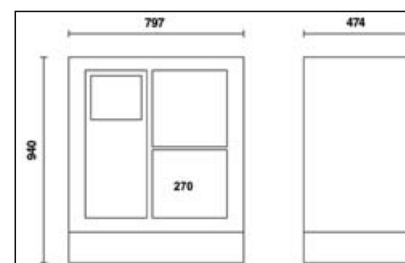

C55 MS

€ 1.150,00



055000204

C55T3

carrello

- 3 ripiani ricoperti in gomma millerighe antiscivolo
- Maniglia ergonomica
- Doppia possibilità di fissaggio del ripiano centrale
- Quattro ruote girevoli Ø 100 mm (due con freno)
- Capacità di carico statico: 200 kg. (distribuita sui 3 ripiani)

📦 21 kg

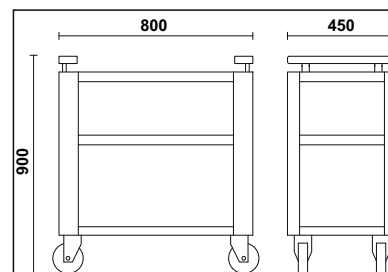

C55T3

€ 215,00



055000219

C55P/MCD

montanti centrali intermedi doppi

10 kg

C55P/MCD

€ 110,00 1 055000257



C55P/2MDX-SX

coppia di montanti DX-SX pareti

10 kg

C55P/2MDX-SX

€ 200,00 1 055000253



C55PM

pensile per arredo officina da 1 metro

• Misure 1024x400x300 mm dotato di molle a gas per facilitare l'apertura e la chiusura dell'anta

24 kg

C55PM

€ 730,00 1 055000302

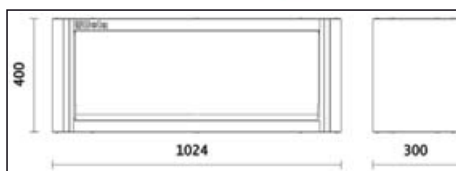

C55PFA-1,0

pannello forato autoportante da 1 metro per arredo officina

Pannello forato in acciaio 1024x25x1000 mm per il sostegno degli utensili

11 kg

C55PFA-1,0

€ 245,00 1 055000316



C55/PF

pannello forato sotto pensile per arredo officina da 1 metro

• Pannello forato 1024x620 mm per il sostegno degli utensili, da sovrapporre a C55PT1,0x0,6

6 kg

C55/PF

€ 95,00 1 055000307

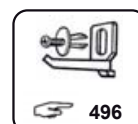
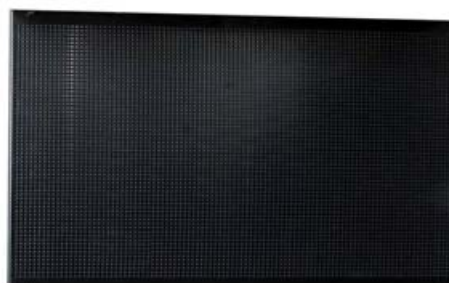

C55PT1,0X0,6

pannello sotto pensile da 1 metro

Misure 1024x25x620 mm

8 kg

C55PT1,0X0,6 € 135,00 1 055000314



C55PTE-1,0

pannello sotto pensile da 1 metro

Misure 1024x620 mm

Con predisposizione per 2 prese elettriche (non incluse)

8 kg

C55PTE-1,0 € 160,00 1 055000319



C55/2PM

parete con 2 pensili per arredo ufficio

- 2 pensili 1024x400x300 mm dotati di molle a gas per facilitare l'apertura e la chiusura delle ante.
- 2 pannelli a muro 1024x620 mm con predisposizione per alloggiare pannelli forati portautensili C55/PF (da ordinare separatamente)
- Fornita con struttura portante
- Abbinabile al banco di lavoro da 2 metri.

80 kg

C55 2PM € 2.040,00 1 055000301

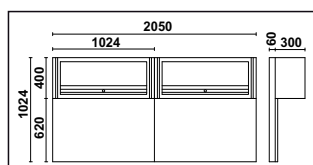

C55PFA-0,8

pannello forato autoportante da 0,8 metri per arredo officina

Pannello forato in acciaio 800x25x1000 mm per il sostegno degli utensili

10 kg

C55PFA-0,8 € 225,00 1 055000315

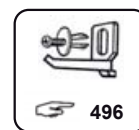
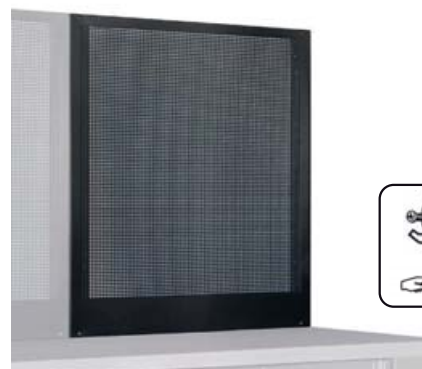

C55PM/M0,8

Pensile 0,8 metri per arredo officina

misure 800x400 mm dotato di molle a gas per facilitare l'apertura e la chiusura dell'anta

19 kg

C55PM/M0,8 € 700,00 1 055000312

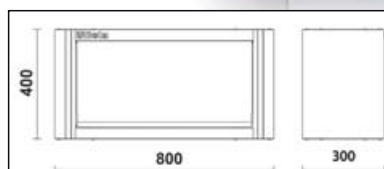

C55PTE-0,8

pannello sotto pensile da 0,8 metri

Misure 800x620 mm

Con predisposizione per 1 presa elettrica (non inclusa)

6 kg

C55PTE-0,8 € 145,00 1 055000318



C55PT0,8X0,6

pannello sotto pensile da 0,8 metri

Misure 800x25x620 mm

7,8 kg

C55PT0,8X0,6 € 125,00 1 055000313



C55/1PF

pannello forato portautensili per arredo officina

• Pannello forato 800x620 mm per il sostegno degli utensili

5 kg

C55/1PF € 85,00 1 055000309

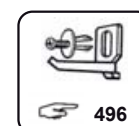
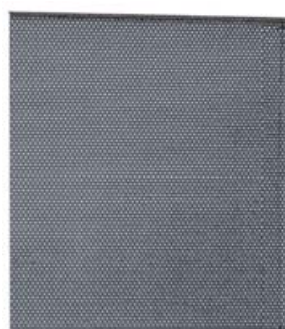

C55PS

parete portautensili con tapparella per arredo officina

- Tapparella in alluminio, manovrabile verticalmente, con serratura
- Pannello forato amovibile per il sostegno degli utensili
- Fornita con struttura portante
- Kit di 50 ganci GPS incluso
- Abbinabile al banco di lavoro da 2 metri.

88 kg

C55PS-O	€ 1.440,00	1	055000250
C55PS-G	€ 1.440,00	1	055000255

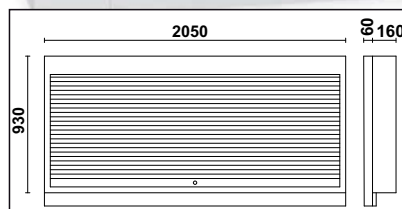

C55PSE

parete portautensili con tapparella e predisposizione per 2 prese elettriche

- Tapparella in alluminio, manovrabile verticalmente, con serratura
- Pannello forato amovibile per il sostegno degli utensili
- Fornita con struttura portante
- Kit di 50 ganci GPS incluso
- Con predisposizione per prese elettriche (non incluse)
- Abbinabile al banco di lavoro da 2 metri.

88 kg

C55PSE-O	€ 1.455,00	1	055000258
C55PSE-G	€ 1.455,00	1	055000260

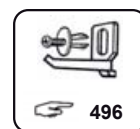
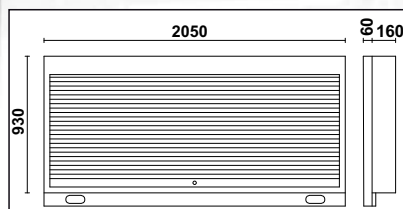

C55AE

profilo 2 metri con predisposizione elettrica

Misure 2050x25x90mm
Con predisposizione per 2 prese elettriche

1,5 kg

C55AE	€ 135,00	1	055000325
-------	----------	---	-----------



C55AC

angolo completo autoportante

Piano di lavoro da 700x700 mm con gambe
2 pareti superiori porta utensili complete di 2 mensole per fissaggio 670x160 mm

📦 66 kg

C55AC O	€ 1.670,00	1	055000360
C55AC G	€ 1.670,00	1	055000380

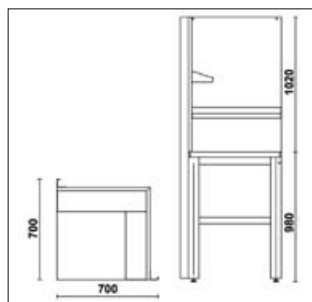

C55AC O
C55AC G



C55KAI

elemento angolare 700x700 con gambe

• Piano di lavoro in lamiera verniciata 700x700 mm rivestito da uno strato di PVC antiurto e antigraffio resistente agli idrocarburi

📦 32 kg

C55KAI O	€ 960,00	1	055000365
C55KAI G	€ 960,00	1	055000385

C55AC O
C55AC G

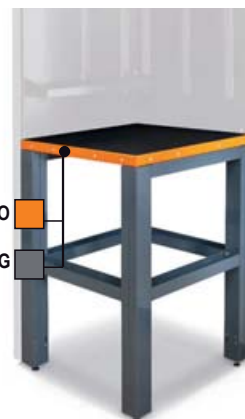

C55KAS

angolo superiore con pareti porta utensili

• 2 Pareti forate 700x1000 mm
• 2 Mensole per fissaggio 670x160 mm

📦 24 kg

C55KAS	€ 710,00	1	055000370
--------	----------	---	-----------



C55MP

Mensole in acciaio per pareti angolo

Misure 670x160x80 mm

C55MP	€ 100,00	1	055000374
-------	----------	---	-----------



C55B/1

estensione da 1 metro per arredo officina con modulo fisso C55M7

Piano di lavoro 1024x700 mm rivestito da uno strato di PVC antiurto e antigraffio resistente agli idrocarburi

- Gamba universale dotata di piedini regolabili in altezza
- 1 modulo fisso: 7 cassetti da 588x367 mm, montati su guide telescopiche a sfera
- Sistema di apertura in alluminio posizionato su tutta la lunghezza del cassetto
- Piano dei cassetti protetto da tappetini di gomma espansa
- Serratura centralizzata frontale

📦 127 kg



C55BO/1

C55BG/1



h	max
70 mm	30 kg
245 mm	40 kg

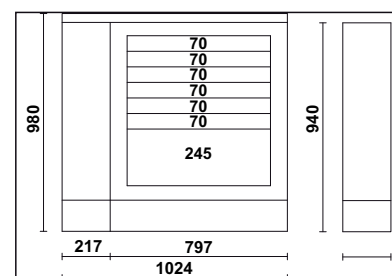
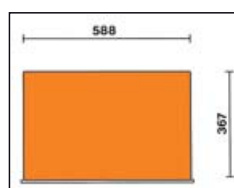

	€		
C55BO/1	2.185,00	1	055000090
C55BG/1	2.185,00	1	055000091

C55C

armadietti Cargo linea RSC55

Sono realizzati sulla base di accurate ricerche presso qualificati utilizzatori professionali ed offrono le soluzioni ideali per operare in modo confortevole e razionale.

L'apertura dei pannelli forati delle due antine permette lo sfruttamento anche della loro superficie interna.

Caratteristiche principali:

- 1 cassetto montato su guide telescopiche.
- Possibilità di modificare facilmente la disposizione degli utensili in funzione delle proprie esigenze.
- Posizionamento a parete per mezzo di due asole situate posteriormente.
- Serratura per chiusura contemporanea di antine e cassetto.
- Termoformato vuoto per bussole e accessori da 1/2".

📦 37 kg

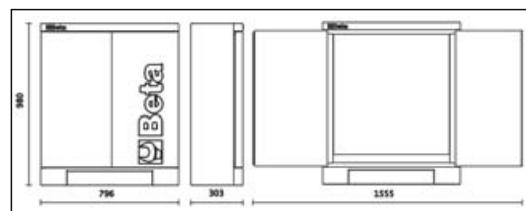
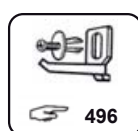

	€		
C55C	603,00	1	055000400

C55A1

armadio in lamiera a un'anta per arredo officina

- 3 ripiani amovibili regolabili in altezza
- Dotato di serratura
- Misure utili interne: 1770x420x420 mm

📦 50 kg

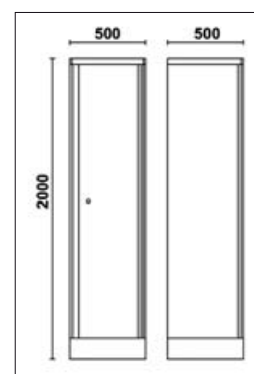

C55A1

€ 530,00 1 055000411

C55A1/R42

ripiano interno per armadio C55A1

📦 2,4 kg

C55A1/R42

420x420 mm

€ 23,00 1 055000461

Beta

C55A2

armadio in lamiera a due ante per arredo officina

- 3 ripiani amovibili regolabili in altezza
- Dotato di serratura
- Misure utili interne: 1770x700x420 mm

📦 72 kg

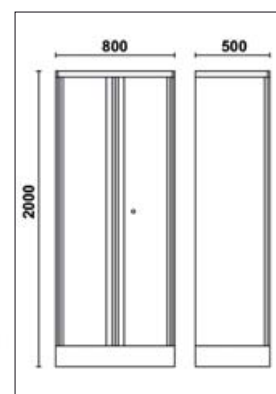
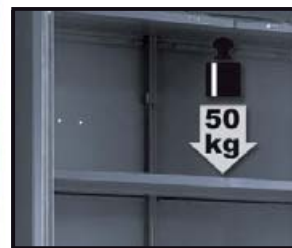

C55A2

€ 710,00 1 055000412

C55A2/R70

ripiano interno per armadio C55A2

📦 3,5 kg

C55A2/R70

700x420 mm

€ 37,00 1 055000462

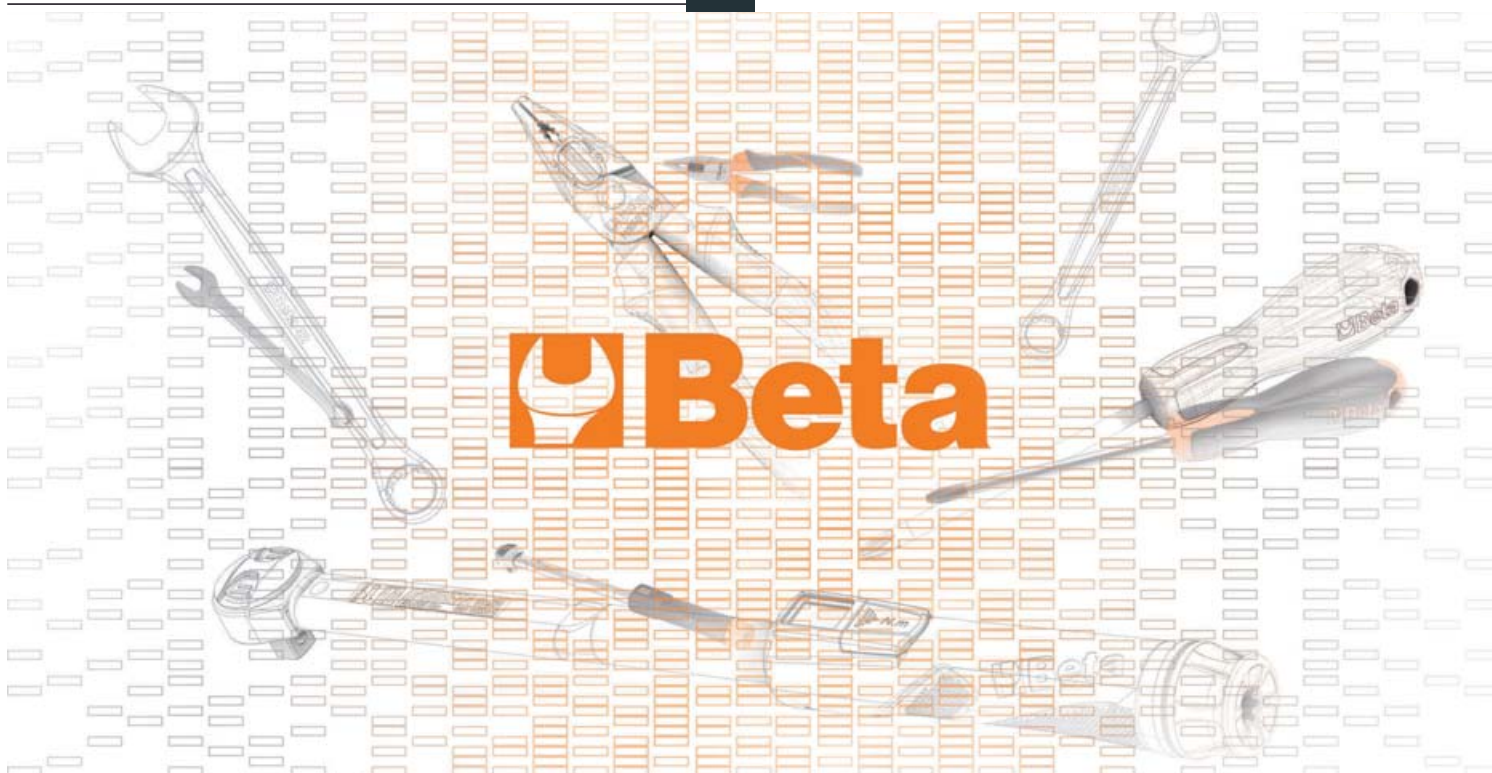

C55AT1

armadio in lamiera con anta trasparente in policarbonato per arredo ufficio

- 3 ripiani amovibili regolabili in altezza
- Dotato di serratura
- Misure utili interne: 1770x420x420 mm

41 kg

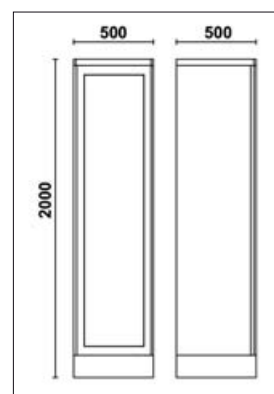

C55AT1

€ 590,00 1 055000421

C55AT2

armadio in lamiera con due ante trasparenti in policarbonato per arredo ufficio

- 3 ripiani amovibili regolabili in altezza
- Dotato di serratura
- Misure utili interne: 1770x700x420 mm

56 kg

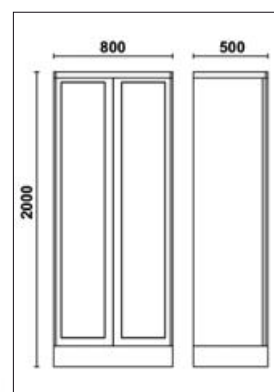

C55AT2

€ 800,00 1 055000422

C55STR

nastro adesivo colorato 25 m

permette di personalizzare il colore degli inserti verticali dell'arredo officina C55



	€		
C55STR-O/2011	54,00	1	055000901
C55STR-R/3000	54,00	1	055000903
C55STR-V/6029	54,00	1	055000906
C55STR-W/9016	54,00	1	055000907
C55STR-Y/1023	54,00	1	055000905
C55STR-B/5015	54,00	1	055000904
C55STR-GO/1035	54,00	1	055000909
C55STR-S/9006	54,00	1	055000902



C45LMP

lampada LED per arredo officina C45 - RSC55

- Lunghezza: 630 mm
- Pratico fissaggio sotto all'armadietto pensile tramite adesivi
- Interruttore ON/OFF
- 570 lumen

Input: 100-240V 0,6A
Output: 12V 1.50A 18.0W

307 g

	€		
C45LMP	90,00	1	045000320



9562P2

tappeto con logo BETA 200x80 cm

- particolarmente indicato per utilizzi con arredo officina C55, C45 o come tappeto sottomoto
- protegge il suolo da perdite d'olio, benzina e rispetta l'ambiente
- facile da pulire, fondo gommato ed antiscivolo

	€		
9562P2	135,00	1	095620400



9562P12

rotolo tappeto multi logo 12 m x 80 cm

- permette di personalizzare la lunghezza del tappeto in base alle esigenze dell'utilizzatore
- protegge il suolo da perdite d'olio, benzina e rispetta l'ambiente
- facile da pulire, fondo gommato ed antiscivolo

	€		
9562P12	680,00	1	095620425



C45



C45/X

combinazione arredo officina C45

Combinazione composta da:

- Piano di lavoro in MDF rivestito in acciaio inossidabile (C45PX/3-2,0MT)
- Modulo fisso con 7 cassetti (C45M7)
- Modulo fisso di servizio (C45MS)
- Cassettiera mobile con 7 cassetti (C45C7)
- Armadio a 2 ante (C45AS2)
- 3 pannelli forati portautensili (C45PF)
- 3 pensili a muro (C45PM)
- 3 staffe per parete tipo largo (C45SL)
- 1 staffa per parete tipo stretto (C45SS)

📦 305 kg

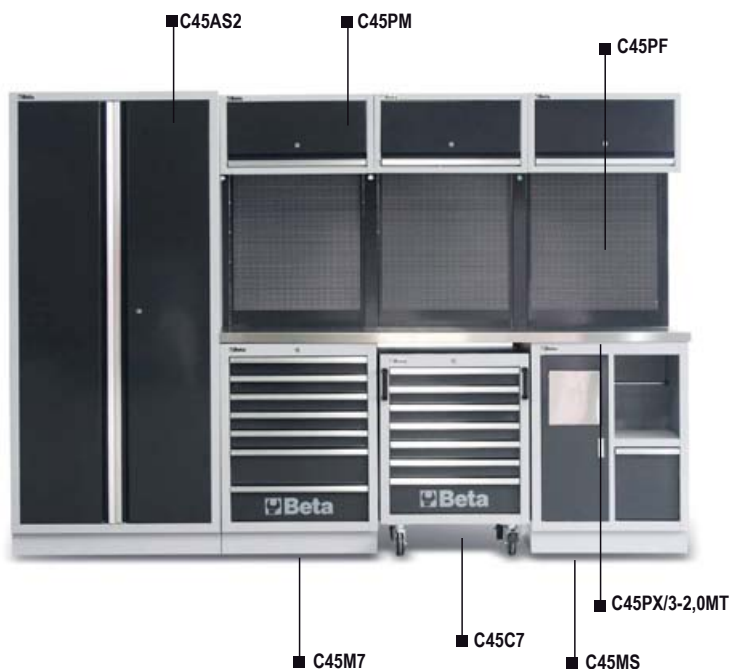

C45/X

€ 3.150,00 1 045000010



C45/W

combinazione arredo officina C45

Combinazione composta da:

- Piano di lavoro in legno multistrato (C45PW/3-2,0MT)
- Modulo fisso con 7 cassetti (C45M7)
- Modulo fisso di servizio (C45MS)
- Cassettiera mobile con 7 cassetti (C45C7)
- Armadio a 2 ante (C45AS2)
- 3 pannelli forati portautensili (C45PF)
- 3 pareti con 1 pensile a muro (C45PM)
- 3 staffe per parete tipo largo (C45SL)
- 1 staffa per parete tipo stretto (C45SS)

📦 303 kg

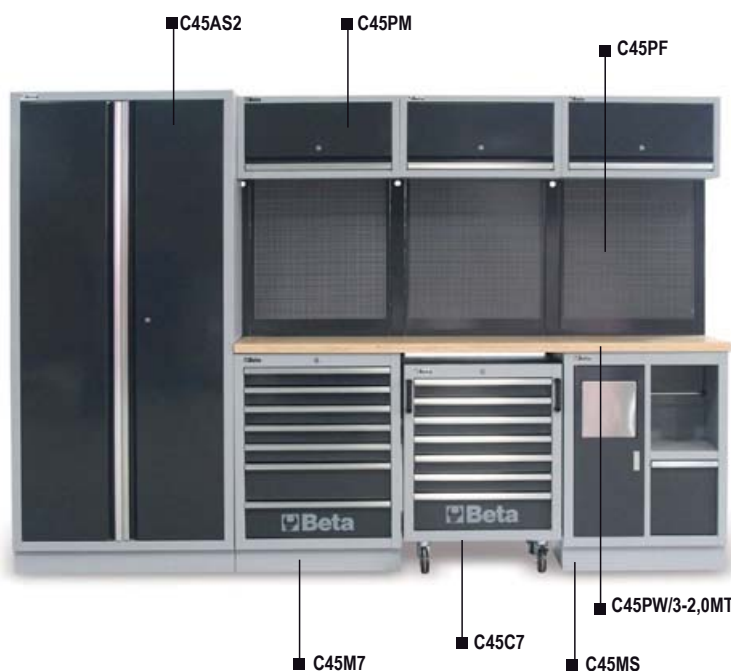

C45/W

€ 3.060,00 1 045000020



C45/AX

combinazione arredo officina C45

Combinazione composta da:

- Piano di lavoro in MDF rivestito in acciaio inossidabile (C45PX/3-2,0MT)
- Modulo fisso con 7 cassetti (C45M7)
- Modulo fisso di servizio (C45MS)
- Modulo fisso con 2 antine (C45MA)
- 3 pensili a muro (C45PM)
- 3 pannelli forati portautensili (C45PF)
- 2 staffe per parete tipo largo (C45SL)
- 2 staffa per parete tipo stretto (C45SS)

206 kg

C45/AX

€ 2.210,00 1 045000030



C45/AW

combinazione banchi arredo officina C45

Combinazione composta da:

- Piano di lavoro in legno multistrato (C45PW/3-2,0MT)
- Modulo fisso con 2 antine (C45MA)
- Modulo fisso con 7 cassetti (C45M7)
- Modulo fisso di servizio (C45MS)
- 3 pensili a muro (C45PM)
- 3 pannelli forati portautensili (C45PF)
- 2 staffe per parete tipo stretto (C45SS)
- 2 staffe per parete tipo largo (C45SL)

204 kg

C45/AW

€ 2.120,00 1 045000040

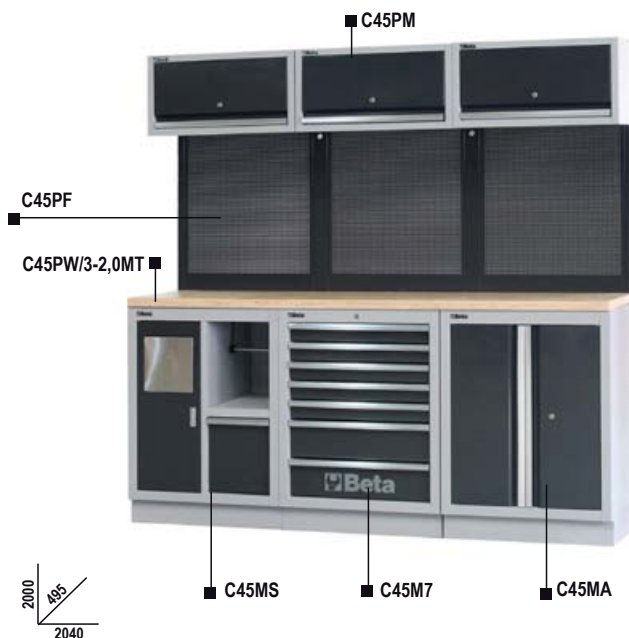

C45/BX

combinazione arredo officina C45

Combinazione composta da:

- Piano di lavoro in MDF rivestito in acciaio inossidabile (C45PX/2-1,3MT)
- Modulo fisso con 5 cassetti (C45M5)
- Modulo fisso con 2 antine (C45MA)
- Armadio a 1 anta (C45AS1)
- 2 pensili a muro (C45PM)
- 2 pannelli forati portautensili (C45PF)
- 2 staffe per parete tipo largo (C45SL)
- 1 staffa per parete tipo stretto (C45SS)

191 kg

C45/BX

€ 1.955,00 1 045000043



C45/BW

combinazione arredo officina C45

Combinazione composta da:

- Piano di lavoro in legno multistrato (C45PW/2-1,3MT)
- Modulo fisso con 5 cassetti (C45M5)
- Modulo fisso con 2 antine (C45MA)
- Armadio a 1 anta (C45AS1)
- 2 pensili a muro (C45PM)
- 2 pannelli forati portautensili (C45PF)
- 2 staffe per parete tipo largo (C45SL)
- 1 staffa per parete tipo stretto (C45SS)

190 kg

C45/BW

€ 1.870,00 1 045000053

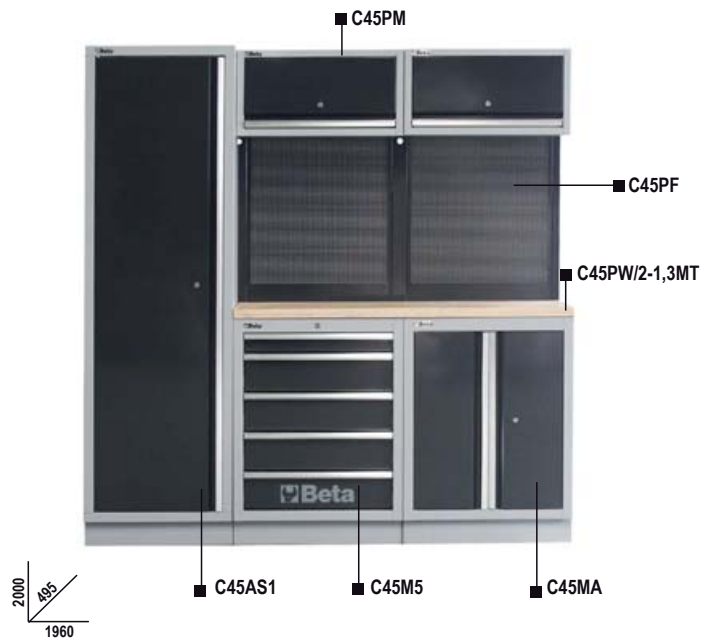

C45/DX

combinazione arredo officina C45

Combinazione composta da:

- 1 piano di lavoro in MDF rivestito in acciaio inossidabile (C45PX/3-2,0MT)
- 1 piano di lavoro in MDF rivestito in acciaio inossidabile (C45PX/2-1,3MT)
- 1 modulo fisso con 7 cassetti (C45M7)
- 1 cassettiera mobile con 7 cassetti (C45C7)
- 1 modulo fisso di servizio (C45MS)
- 1 modulo fisso con 5 cassetti (C45M5)
- 1 modulo fisso con 2 antine (C45MA)
- 1 angolo completo autoportante con piano di lavoro in MDF rivestito in acciaio inossidabile (C45CORNER/X)
- 5 pannelli forati portautensili (C45PF)
- 5 pensili a muro (C45PM)
- 7 staffe per parete tipo largo (C45SL)
- 2 staffe per parete tipo stretto (C45SS)
- 2 armadi a 1 anta (C45AS1)

572,3 kg

C45/DX

€ 6.080,00 1 045000075

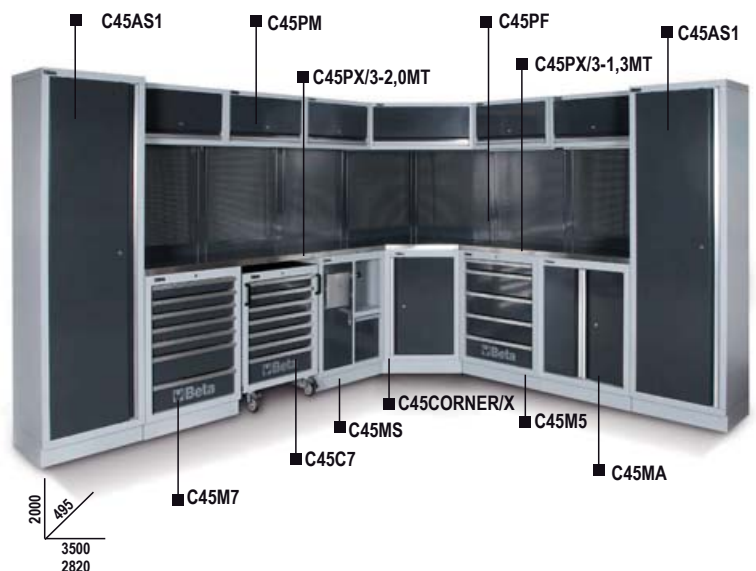

C45/DW

combinazione arredo officina C45

Combinazione composta da:

- 1 piano di lavoro in legno multistrato (C45PW/3-2,0MT)
- 1 piano di lavoro in legno multistrato (C45PW/2-1,3MT)
- 1 modulo fisso con 7 cassetti (C45M7)
- 1 cassettiera mobile con 7 cassetti (C45C7)
- 1 modulo fisso di servizio (C45MS)
- 1 modulo fisso con 5 cassetti (C45M5)
- 1 modulo fisso con 2 antine (C45MA)
- 1 angolo completo autoportante con piano di lavoro in legno (C45CORNER/W)
- 5 pannelli forati portautensili (C45PF)
- 5 pensili a muro (C45PM)
- 7 staffe per parete tipo largo (C45SL)
- 2 staffe per parete tipo stretto (C45SS)
- 2 armadi a 1 anta (C45AS1)

568,5 kg

C45/DW

€ 5.860,00 1 045000076

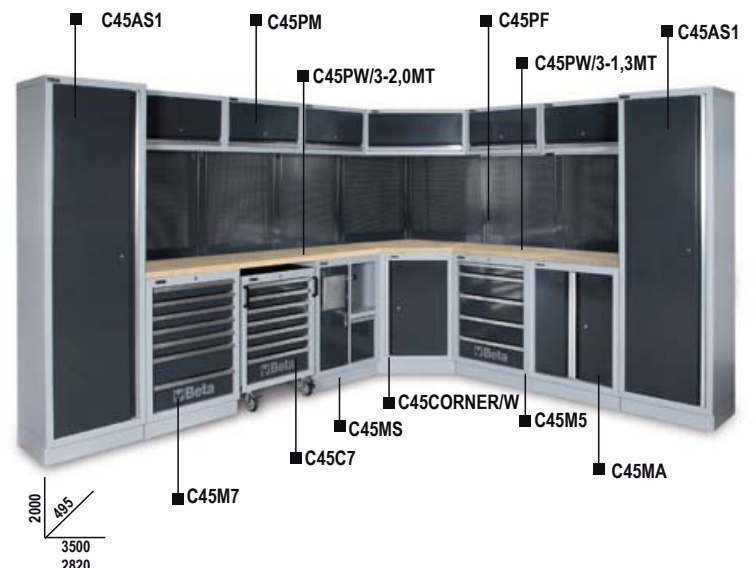

C45/EX

combinazione arredo officina C45

Combinazione composta da:

- 2 pannelli forati portautensili (C45PF)
- 2 pensili a muro (C45PM)
- 2 staffe per parete tipo largo (C45SL)
- 1 staffa per parete tipo stretto (C45SS)
- 1 armadio a 1 anta (C45AS1)

• Modulo fisso con 7 cassetti e piano di lavoro in MDF rivestito in acciaio inossidabile (C45M7A/X):

- 1 cassetto da 1248x406 mm
- 6 cassetti da 782x406 mm
- 5 cassetti altezza 85 mm
- 1 cassetto altezza 155 mm
- 1 vano portaoggetti con ripiano intermedio e antina di chiusura

174,6 kg

C45/EX

€ 2.080,00 1 045000078

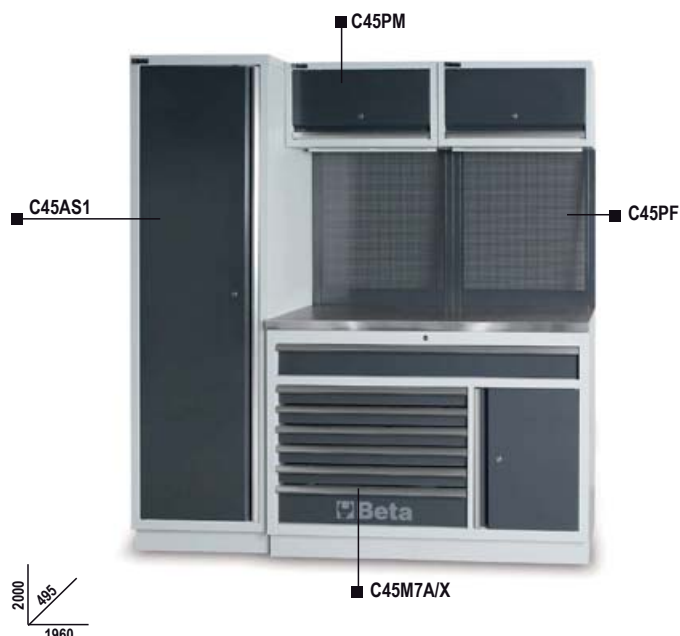

C45/EW

combinazione arredo officina C45

Combinazione composta da:

- 2 pannelli forati portautensili (C45PF)
- 2 pensili a muro (C45PM)
- 2 staffe per parete tipo largo (C45SL)
- 1 staffa per parete tipo stretto (C45SS)
- 1 armadio a 1 anta (C45AS1)

• Modulo fisso con 7 cassetti e piano di lavoro in legno multistrato (C45M7A/W):

- 1 cassetto da 1248x406 mm
- 6 cassetti da 782x406 mm
- 5 cassetti altezza 85 mm
- 1 cassetto altezza 155 mm
- 1 vano portaoggetti con ripiano intermedio e antina di chiusura

173,6 kg

C45/EW

€ 2.000,00 1 045000079



C45/CX

combinazione arredo officina C45

Combinazione composta da:

- Piano di lavoro in MDF rivestito in acciaio inossidabile (C45PX/2-1,3MT)
- Modulo fisso con 7 cassetti (C45M7)
- Modulo fisso di servizio (C45MS)
- Armadio a 1 anta (C45AS1)
- 2 pensili a muro (C45PM)
- 2 pannelli forati portautensili (C45PF)
- 2 staffe per parete tipo largo (C45SL)
- 1 staffa per parete tipo stretto (C45SS)

199 kg

C45/CX

€ 2.110,00 1 045000063



C45/CW

combinazione arredo officina C45

Combinazione composta da:

- Piano di lavoro in legno multistrato (C45PW/2-1,3MT)
- Modulo fisso con 7 cassetti (C45M7)
- Modulo fisso di servizio (C45MS)
- Armadio a 1 anta (C45AS1)
- 2 pensili a muro (C45PM)
- 2 pannelli forati portautensili (C45PF)
- 2 staffe per parete tipo largo (C45SL)
- 1 staffa per parete tipo stretto (C45SS)

198 kg

C45/CW

€ 2.025,00 1 045000073

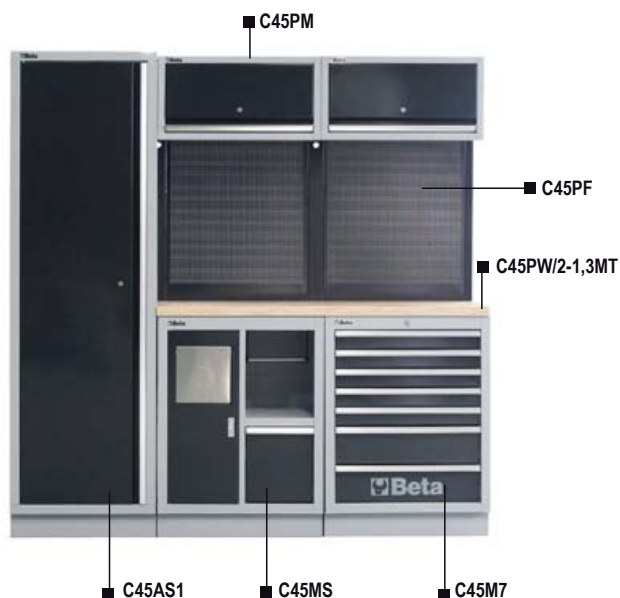

C45/BPX-1,3

combinazione banchi arredo officina C45

Combinazione composta da

- Piano di lavoro in MDF rivestito in acciaio inossidabile (C45PX/2-1,3MT)
- Modulo fisso con 7 cassetti (C45M7)
- Modulo fisso con 5 cassetti (C45M5)
- 2 pannelli forati portautensili (C45PF)
- 1 staffa per parete tipo largo (C45SL)
- 2 staffe per parete tipo stretto (C45SS)

140 kg

C45/BPX-1,3

€ 1.400,00 1 045000083



C45/BPW-1,3

combinazione banchi arredo officina C45

Combinazione composta da:

- Piano di lavoro in legno multistrato (C45PW/2-1,3MT)
- Modulo fisso con 7 cassetti (C45M7)
- Modulo fisso con 5 cassetti (C45M5)
- 2 pannelli forati portautensili (C45PF)
- 1 staffa per parete tipo largo (C45SL)
- 2 staffe per parete tipo stretto (C45SS)

139 kg

C45/BPW-1,3

€ 1.315,00 1 045000093



C45/BPX-2,0

combinazione banchi arredo officina C45

Combinazione composta da:

- Piano di lavoro in MDF rivestito in acciaio inossidabile (C45PX/3-2,0MT)
- Modulo fisso con 7 cassetti (C45M7)
- Modulo fisso con 5 cassetti (C45M5)
- 3 pannelli forati portautensili (C45PF)
- 2 staffe per parete tipo largo (C45SL)
- 2 staffe per parete tipo stretto (C45SS)

158 kg

C45/BPX-2,0

€ 1.585,00



1



045000090

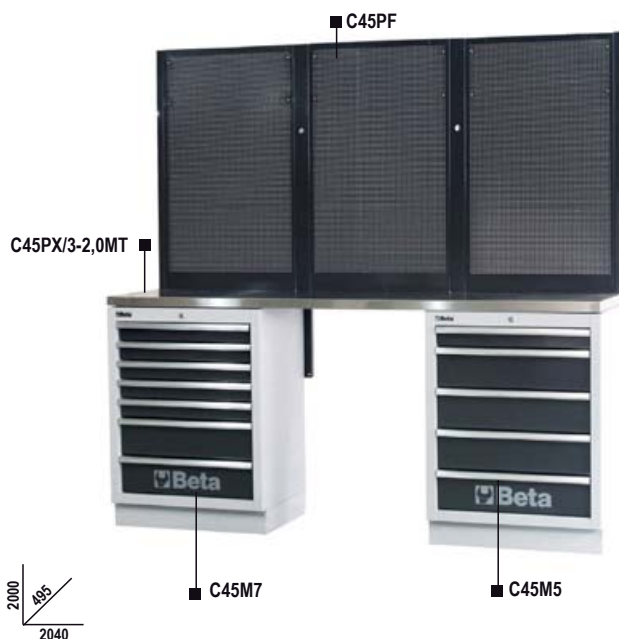

C45/BPW-2,0

combinazione banchi arredo officina C45

Combinazione composta da:

- Piano di lavoro in legno multistrato (C45PW/3-2,0MT)
- Modulo fisso con 7 cassetti (C45M7)
- Modulo fisso con 5 cassetti (C45M5)
- 3 pannelli forati portautensili (C45PF)
- 2 staffe per parete tipo largo (C45SL)
- 2 staffe per parete tipo stretto (C45SS)

156 kg

C45/BPW-2,0

€ 1.495,00



1



045000100



C45M7A/X

modulo fisso con 7 cassetti per arredo officina

- Piano di lavoro da 1360mm in MDF rivestito in acciaio inossidabile
- 1 cassetto da 1248x406 mm, montato su guide telescopiche a sfera
- 6 cassetti da 782x406 mm, montati su guide telescopiche a sfera:
 - 5 cassetti altezza 85 mm
 - 1 cassetto altezza 155 mm
- Piano dei cassetti protetto da tappetini di gomma espansa
- Serratura centralizzata frontale
- Predisposizione per l'inserimento dei termoformati
- 1 vano portaoggetti con ripiano intermedio e antina di chiusura, misure interne 504x424x597 mm

81 kg

C45M7A/X

€ 1.050,00



1



045000160



h	max
65 mm	25 kg
105 mm	40 kg
145 mm	30 kg

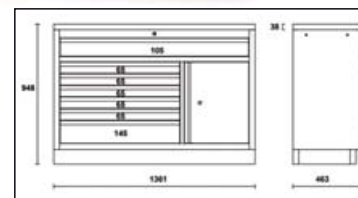

C45M7A/W

modulo fisso con 7 cassetti per arredo officina

- Piano di lavoro da 1360mm in legno multistrato
- 1 cassetto da 1248x406 mm, montato su guide telescopiche a sfera
- 6 cassetti da 782x406 mm, montati su guide telescopiche a sfera:
 - 5 cassetti altezza 85 mm
 - 1 cassetto altezza 155 mm
- Piano dei cassetti protetto da tappetini di gomma espansa
- Serratura centralizzata frontale
- Predisposizione per l'inserimento dei termoformati
- 1 vano portaoggetti con ripiano intermedio e antina di chiusura, misure interne 504x424x597 mm

📦 80 kg



h	max
65 mm	25 kg
105 mm	40 kg
145 mm	30 kg

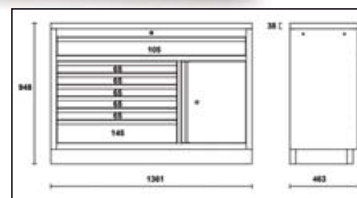

C45M7A/W

€ 970,00 1 045000170

C45PX/2-1,3MT

piano di lavoro in MDF rivestito in acciaio inossidabile da 1,3 metri per banco arredo officina C45

Piano di lavoro in MDF rivestito in acciaio inossidabile 1361x463 mm, spessore banco 38 mm

📦 21 kg



C45PX/2-1,3MT

€ 235,00 1 045000103

C45PW/2-1,3MT

piano di lavoro in legno da 1,3 metri per banco arredo officina C45

Piano di lavoro in legno 1361x463 mm, spessore 38 mm
Fori per la collocazione di una morsa 1599P/150 da ordinare separatamente

📦 20 kg



C45PW/2-1,3MT

€ 150,00 1 045000113

C45PX/3-2,0MT

piano di lavoro in MDF rivestito in acciaio inossidabile da 2 metri per banco arredo officina C45

Piano di lavoro in MDF rivestito in acciaio inossidabile 2041x463 mm, spessore banco 38 mm

📦 31,8 kg



C45PX/3-2,0MT

€ 315,00 1 045000110

C45PW/3-2,0MT

piano di lavoro in legno da 2 metri per banco arredo officina C45

Piano di lavoro in legno 2041x463 mm, spessore 38 mm
Fori per la collocazione di una morsa 1599P/150 da ordinare separatamente

📦 30 kg



C45PW/3-2,0MT

€ 225,00 1 045000120

C45C7

cassettiera mobile con 7 cassetti per arredo officina

- 7 cassetti da 532x406 mm, montati su guide telescopiche a sfera
- 4 ruote girevoli Ø 100 mm (1 con freno)
- Piano dei cassetti protetto da tappetini di gomma espansa
- Serratura centralizzata frontale
- Predisposizione per l'inserimento dei termoformati
- Maniglie integrate nella struttura per una facile movimentazione

📦 50 kg

h	max
65 mm	25 kg
145 mm	30 kg

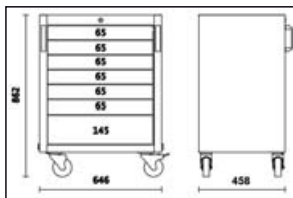
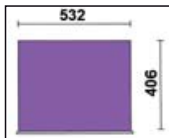

C45C7

€ 525,00 1 045000207

C45M5

modulo fisso con 5 cassetti per arredo officina

- 5 cassetti da 566x406 mm, montati su guide telescopiche a sfera
- Piano dei cassetti protetto da tappetini di gomma espansa
- Serratura centralizzata frontale
- Predisposizione per l'inserimento dei termoformati

📦 49,3 kg

h	max
65 mm	25 kg
145 mm	30 kg

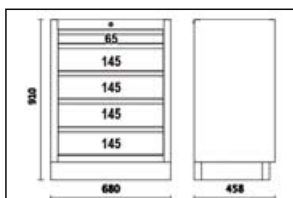
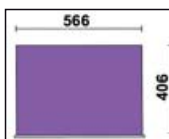

C45M5

€ 435,00 1 045000215

C45M7

modulo fisso con 7 cassetti per arredo officina

- 7 cassetti da 566x406 mm, montati su guide telescopiche a sfera
- Piano dei cassetti protetto da tappetini di gomma espansa
- Serratura centralizzata frontale
- Predisposizione per l'inserimento dei termoformati

📦 54,3 kg

h	max
65 mm	25 kg
145 mm	30 kg

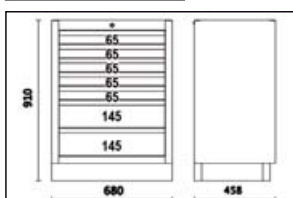
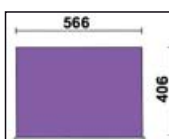

C45M7

€ 505,00 1 045000217

C45MS

modulo fisso di servizio per arredo officina C45

- Cestino portarifiuti integrato
- Vano portacarta per rotoli preforati

📦 37 kg

C45MS € 340,00 1 045000219

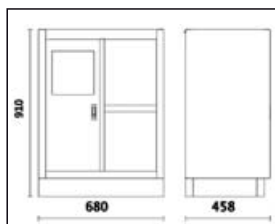

C45MA

modulo fisso con 2 antine per arredo officina

- Dotato di serratura
- Ripiano interno regolabile in altezza
- Misure interne 670x420 mm

📦 29,4 kg

C45MA € 255,00 1 045000212

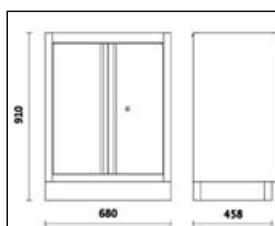

C45SS

staffe laterali per parete tipo stretto per C45

1420x32,5x30 mm

📦 1,5 kg

C45SS € 20,00 1 045000332



C45SL

staffe laterali per parete tipo largo per C45

1420x65x30 mm

📦 2 kg

C45SL € 25,00 1 045000365



C45PF

1 pannello forato portautensili per arredo officina C45

Pannello forato 1052x614,5 mm
per il sostegno degli utensili

5,3 kg

C45PF

€ 80,00 1 045000311



C45CORNER/X

angolo completo autoportante

- Pensile ad angolo con serratura dotato di molle a gas per facilitare l'apertura e la chiusura dell'anta
- 2 Pannelli forati 1050x860 mm per il sostegno degli utensili
- Piano di lavoro angolare in acciaio inox da 860 x 860 mm
- modulo inferiore angolare con ampio vano porta-oggetti

94 kg

C45CORNER/X

€ 1.190,00 1 045000400



C45CORNER/W

angolo completo autoportante

- Pensile ad angolo con serratura dotato di molle a gas per facilitare l'apertura e la chiusura dell'anta
- 2 Pannelli forati 1050x860 mm per il sostegno degli utensili
- Piano di lavoro angolare in legno multistrato da 860 x 860 mm
- modulo inferiore angolare con ampio vano porta-oggetti

93 kg

C45CORNER/W

€ 1.140,00 1 045000410



C45PM

Pensile a muro per banco arredo officina C45

dotato di molle a gas per facilitare l'apertura e la chiusura dell'anta
680x281x350 mm

10 kg

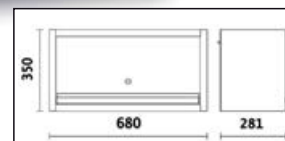

C45PM

€ 155,00



1



045000301

C45AS1

armadio in lamiera a 1 anta per arredo officina
con staffe

- 4 ripiani amovibili regolabili in altezza
- Dotato di serratura
- Misure interne 590x430 mm

57,5 kg

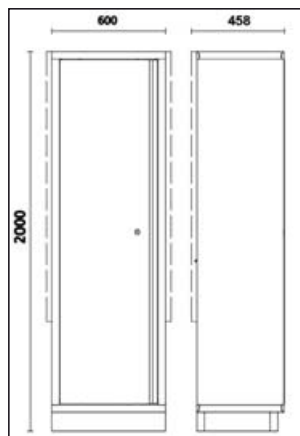

C45AS1

€ 515,00



1



045000450

C45AS2

armadio in lamiera a 2 ante per arredo officina
con staffe

- 4 ripiani amovibili regolabili in altezza
- Dotato di serratura
- Misure interne 910x430 mm

80 kg

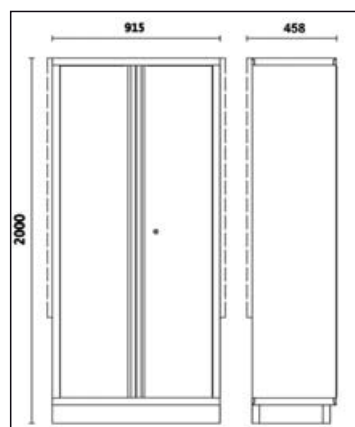

C45AS2

€ 685,00



1



045000480

C45LMP

lampada LED per arredo officina C45 - RSC55

- Lunghezza: 630 mm
- Pratico fissaggio sotto all'armadietto pensile tramite adesivi
- Interruttore ON/OFF
- 570 lumen

Input: 100-240V 0,6A
Output: 12V 1.50A 18.0W

📦 307 g

C45LMP € 90,00 1 045000320



PM/5C

portaminuterie a 5 vaschette in materiale plastico, con supporto

- Dimensione interna della vaschetta 95x120 mm
- Abbinabile alle pareti portautensili serie C45 e RSC55

📦 1,8 kg

PM/5C € 73,00 1 088880450



PM/6C

portaminuterie a 6 vaschette in materiale plastico, con supporto

- Dimensione interna della vaschetta 80x60 mm
- Abbinabile alle pareti portautensili serie C45 e RSC55

📦 970 g

PM/6C € 57,00 1 088880440



CP

cestino portafilaconi da parete in acciaio

- Abbinabile ai pannelli portautensili da parete

CP € 68,00 1 088880470



CASSETTIERE E CONTENITORI

		Applicazione	N° pezzi	C22S	C23S	C23SC	C23ST	C24S/5	C24S/6	C24S/7	C24S-CAB	C24SA/6	C37/6	C39/6	C24SL	C24SA-XL/7	C37/7	C39/7			
UTENSILI SCIOLTI	Senza supporti	5902MT	Movimento terra	106	☐ 453	☐ 453	☐ 453														
		5902MT/AS	Movimento terra	99	☐ 454	☐ 454	☐ 454														
		5902VI	Manutenzioni industriali	107	☐ 412	☐ 412		☐ 412													
		5904VG/3	Autoriparazione	132							☐ 457	☐ 457									
		5905VG/1	Autoriparazione	94																	
		5905VG/2	Autoriparazione	118																	
	Con supporti	5910VI/3	Manutenzioni industriali	297																	
		5954VG	Autoriparazione	138																	
		5954VI	Manutenzioni industriali	133																	
		5957U-P	Interventi universali	133																	
		5957VG	Autoriparazione	174																	
		5957VI	Manutenzioni industriali	162																	
		5958U	Interventi universali	85																	
		UTENSILI IN MODULI	Morbidi	5904VG/2M	Autoriparazione	170				☐ 455	☐ 455	☐ 455	☐ 455								
5904VU/1M	Interventi universali			91				☐ 422	☐ 422	☐ 422	☐ 422										
5904VU/2M	Interventi universali			151				☐ 423	☐ 423	☐ 423	☐ 423										
5927VU/M	Interventi universali			108	☐ 437	☐ 437	☐ 437														
5935ET/1MB	Elettrotecnica			96																	
5935VG/1MB	Autoriparazione			98																	
5935VI/2MB	Manutenzioni industriali			133																	
5945VUM	Interventi universali			231																	
5988H/7M	Riparazione moto e bici			333																	
5988L/4M	Autoriparazione			273					☐ 443	☐ 443	☐ 443	☐ 443									
5988U6/M	Interventi universali			214																☐ 444	
5988U/7M	Interventi universali			215					☐ 429	☐ 429	☐ 429	☐ 429									
5988VHB-MQ	Elettrotecnica			66					☐ 449	☐ 449	☐ 449	☐ 449									
Rigidi	5904VI/1T			Manutenzioni industriali	98				☐ 413	☐ 413	☐ 413	☐ 413									
	5904VI/2T		Manutenzioni industriali	153				☐ 414												☐ 414	
	5904VI/3T		Manutenzioni industriali	142																	
	5904VG/2T		Autoriparazione	99				☐ 456	☐ 456	☐ 456	☐ 456										
	5904VG/3T		Autoriparazione	102				☐ 458	☐ 458	☐ 458	☐ 458										
	5904VG/5T		Autoriparazione	153				☐ 459		☐ 459	☐ 459										
	5904VU/2T		Interventi universali	104				☐ 424	☐ 424	☐ 424	☐ 424										
	5904VU/3T		Interventi universali	146				☐ 425	☐ 425	☐ 425	☐ 425										
	5904VU/4T		Interventi universali	197				☐ 426	☐ 426	☐ 426	☐ 426										
	5908VG/2T		Autoriparazione	212																	
	5908VI/2T		Manutenzioni industriali	232																	
	5908VU/2T		Interventi universali	161				☐ 427		☐ 427	☐ 427										
	5910VG/3T		Autoriparazione	202																	
	5910VI/3T		Manutenzioni industriali	261																	
	5938U/2T		Interventi universali	210																	

CASSETTIERE E CONTENITORI

C24SA/8		C39/8		C24SA-XL/9		C25	C27S	C28	C30S	C35	C38	C39SM		C39T	C45	C54S	C55	C55PS	C57SP		C57SB	C59C		C59B	
C24S/8	C37/8	C24SA-XL/9		C25	C27S	C28	C30S	C35	C38	C39MD		C39T	C45	C54S	C55	C55PS	C57SA	C58P	C59A	C59B					
														453											
														454											
				412	412																				
457																457						457	457		
				460																					
				461																					
								417																	
															468										
															420										
																	439	439							
																		469							
																		421							
															440			440				440			
455	455					455						455	455				455						455	455	
422	422					422						422	422				422						422	422	
423	423					423						423	423				423						423	423	
					437																				
									445																
									464																
									419																
										467				467											
442	442					442																		442	
443	443											443	443				443						443	443	
444	444					444						444					444						444	444	
429	429					429						429					429						429	429	
449	449					449						449	449				449						449	449	
413	413					413						413	413				413						413	413	
414	414					414						414					414						414	414	
415	415					415						415					415						415	415	
456	456					456						456	456				456						456	456	
458	458					458						458	458				458						458	458	
459	459					459						459					459						459	459	
424	424					424						424	424				424						424	424	
425	425					425						425	425				425						425	425	
426	426											426	426				426						426	426	
						462																			
416	416					416																		416	
427	427					427						427					427						427	427	
								463																	
								418																	
										438															

Manutenzioni industriali



19,5 kg

N. pezzi/Descrizione

Beta N.

N. pezzi/Descrizione

Beta N.

6	cacciaspina Ø 2 - 3 - 4 - 5 - 6 - 8 mm	31	1	forbici per elettricisti lame diritte	1128BMX
1	bulino Ø 3 mm	32	1	pinze universali a grande effetto, finitura industriale ≡ 180 mm	1150GBM
1	scalpelli piatti nervati 200 mm	35	1	pinze a becchi mezzotondi lunghissimi, diritti zigrinati, impugnatura bimatereale, finitura industriale ● 160 mm	1166GBM
26	serie di chiavi combinate 6+32 mm	42NEW/S26	8	giravite lama piatta ● 2,5x50 - 3x75 - 3,5x100 - 4x125 - 5,5x125 - 6,5x150 - 8x200 - 10x200 mm	1260
12	chiavi a forchetta 6x7 - 8x9 - 10x11 - 12x13 - 14x15 - 16x17 - 18x19 - 20x22 - 21x23 - 24x26 - 25x28 - 30x32 mm	55/S12	4	giravite per viti con impronta a croce Phillips® ● PH0x60 - PH1x80 - PH2x100 - PH3x150 mm	1262
9	chiavi maschio esagonale piegate ○ 1,5 - 2 - 2,5 - 3 - 4 - 5 - 6 - 8 - 10 mm	96N/SC9	1	martello tipo tedesco 500 g	1370
1	chiave regolabile a rullino 300 mm	111	1	mazzuola antirimbazzo Ø 40 mm	1392
13	chiavi a bussola esagonali 1/2" con guida ○ 10+22 mm	920A/SB13	1	punta per tracciare	1688A
1	prolunga - 1/2" 125 mm	920/21	1	flessometro 5 m	1692
1	prolunga - 1/2" 255 mm	920/22	1	spessimetro	1708/20
1	snodo 1/2"	920/25	5	serie di 5 lime 200 mm	1719BMA...S5
1	quadro maschio 1/2" con spina scorrevole	920/42	1	seghetto	1726BM
1	cricchetto reversibile 1/2" ⊗	920/55	1	oliatore in metallo a pressione 300 cc	1751
1	pinze regolabili cerniera chiusa 250 mm	1048	1	cutter con lama a settori	1771BM
1	pinza autobloccante 240 mm	1052	1	lampada magnetica snodata con LED ad alta luminosità	1837F
1	tronchesi a grande effetto, a taglianti diagonali, finitura industriale ≡ 160 mm	1084GBM			
1	cesoia a doppia leva dritta 250 mm	1122			



5902VI 1.405,00 059021060

Assortimento consigliato in abbinamento con C22S - C23S - C23ST - C25 - C27S

5904VI/1T

assortimento di 98 utensili in termoformato rigido in ABS

Manutenzioni industriali



14,5 kg

N. pezzi/Descrizione

19	chiavi a bussola esagonali 1/2"
	○ 10+24 - 26 - 27 - 30 - 32 mm
5	chiavi a bussola maschio esagonale 1/2"
	○ 5 - 6 - 8 - 10 - 12 mm
1	prolunga - 1/2" 125 mm
1	prolunga - 1/2" 255 mm
1	snodo 1/2"
1	quadro maschio 1/2" con spina scorrevole
1	cricchetto reversibile 1/2" Ⓞ
16	chiavi combinate 6÷21 mm
5	chiavi combinate 22-24-27-30-32 mm
1	pinze regolabili cerniera chiusa 250 mm
1	pinza autobloccante 240 mm
1	tronchesi a grande effetto taglienti diagonali 160 mm
1	pinza universale 180 mm
1	pinza a becchi mezzotondi diritti 160 mm
1	pinze becchi diritti per anelli elastici, per fori ○ 180 mm
1	pinze becchi piegati per anelli elastici, per fori ○ 170 mm

Beta N.

TR

N. pezzi/Descrizione

Beta N.

TR

920A	T80	1	pinze becchi diritti per anelli elastici, per alberi ● 175 mm	1036	T145
		1	pinze becchi piegati per anelli elastici, per alberi ● 175 mm	1038	T145
920ME	T80	5	lime a taglio mezzodolce 200 mm	1719BMA8/S5	T236
		2	scalpelli piatti nervati 100 - 200 mm	35	T234
920/21	T80	1	martello tipo tedesco 300 g	1370	T234
920/22	T80	1	mazzuola con battenti in materiale plastico Ø 35 mm	1390	T234
920/25	T80	8	chiavi a forchetta 6x7 - 8x9 - 10x11 - 12x13 - 14x15 - 16x17 - 18x19 - 20x22 mm	55	T33
920/42	T80	9	chiavi maschio esagonale piegate ○ 1,5 - 2 - 2,5 - 3 - 4 - 5 - 6 - 8 - 10 mm	96/SC9	T33
920/55	T80	4	giravite lama piatta ● 3x75 - 4x100 - 5,5x150 - 6,5x150 mm	1260	T208
42NEW	T05	3	giravite per viti con impronta a croce Phillips® ⚙ PH0x60 - PH1x80 - PH2x100 mm	1262	T208
42NEW	T06	6	chiavi a T maschio esagonale ○ 2,5 - 3 - 4 - 5 - 6 - 8 mm	951	T68
1048	T153				
1052	T153				
1084	T138				
1150	T138				
1166	T138				
1032	T145				
1034	T145				



5904VI/1T 1.290,00 059041161

Assortimento consigliato in abbinamento con C23ST - C24S - C24SL - C24SL/CAB - C24SA - C24SA-XL - C28 - C37 - C39 da 6 - 7 - 8 cassetti - C39MD - C39SM - C39T - C55 - C59

5904VI/2T

assortimento di 153 utensili in termoformato rigido in ABS

Manutenzioni industriali



T05 T06 T31



T40 T83 T91



T167 T168



T153 T138 T145 T68



T236 T234 T281 T289

22 kg

N. pezzi/Descrizione

16	chiavi combinate 6÷21 mm
5	chiavi combinate 22 - 24 - 27 - 30 - 32 mm
5	cacciaspina Ø 2 - 3 - 4 - 5 - 6 mm
1	bulino Ø 4 mm
12	chiavi a forchetta 6x7 - 8x9 - 10x11 - 12x13 - 14x15 - 16x17 - 18x19 - 20x22 - 21x23 - 24x26 - 27x29 - 30x32 mm
9	chiavi maschio esagonale piegate Ø 1,5 - 2 - 2,5 - 3 - 4 - 5 - 6 - 8 - 10 mm
7	chiavi poligonali curve 6÷29 mm
19	chiavi a bussola esagonali 1/2" Ø 10÷24 - 26 - 27 - 30 - 32 mm
1	prolunga - 1/2" 125 mm
1	prolunga - 1/2" 255 mm
1	snodo 1/2"
1	quadro maschio 1/2" con spina scorrevole
1	cricchetto reversibile 1/2"
13	chiavi a bussola esagonali 1/4" Ø 4÷14 mm
6	chiavi a bussola maschio esagonale 1/4" Ø 2,5÷8 mm
1	prolunga - 1/4" 50 mm
1	prolunga - 1/4" 150 mm
1	snodo 1/4"
1	quadro con impugnatura 1/4"
1	quadro scorrevole 1/4"
1	cricchetto reversibile 1/4"
9	giravite lama piatta ● 3x75 - 3x100 - 4x100 - 4x150 - 5,5x100 - 5,5x150 - 6,5x150 - 8x150 - 10x200 mm
2	giravite nano lama piatta ● 4x30 - 6,5x30 mm
7	giravite per viti con impronta a croce Phillips® ⚙ PH0x60 - PH0x100 - PH1x80 - PH1x120 - PH2x100 - PH2x150 - PH3x150 mm

Beta N.

TR

N. pezzi/Descrizione

Beta N.

TR

42NEW	T05	2	giraviti nano Phillips® ⚙ PH1x30 - PH2x30 mm	1262N	T168
42NEW	T06	1	pinze regolabili cerniera chiusa 250 mm	1048	T153
31	T31	1	pinza autobloccante 240 mm	1052	T153
32	T31	1	tronchesi a grande effetto taglienti diagonali ≤ 160 mm	1084	T138
55	T31	1	pinza a becchi mezzotondi dritti ● 160 mm	1166	T138
		1	pinza universale = 180 mm	1150	T138
96N/SC9	T31	1	pinze becchi dritti per anelli elastici, per fori ○ 180 mm	1032	T145
		1	pinze becchi piegati per anelli elastici, per fori ○ 170 mm	1034	T145
90	T40	1	pinze becchi dritti per anelli elastici, per alberi ● 175 mm	1036	T145
920A	T83	1	pinze becchi piegati per anelli elastici, per alberi ● 175 mm	1038	T145
		6	chiavi a T maschio esagonale Ø 2,5 - 3 - 4 - 5 - 6 - 8 mm	951	T68
920/21	T83	5	lime a taglio mezzodolce 200 mm	1719BMA8/S5	T236
920/22	T83	2	scalpelli piatti nervati 100 - 200 mm	35	T234
920/25	T83	1	martello tipo tedesco 300 g	1370	T234
920/42	T83	1	mazzuola con battenti in materiale plastico Ø 35 mm	1390	T234
920/55	T83	1	rivettatrice	1741B	T281
900	T91	100	rivetti 2,9x6 mm	1741RV...K	T281
900ME	T91	100	rivetti 3,2x8 mm	1741RV...K	T281
900/20	T91	100	rivetti 3,8x10 mm	1741RV...K	T281
900/21	T91	100	rivetti 4x12 mm	1741RV...K	T281
900/25	T91	100	rivetti 4,8x12 mm	1741RV...K	T281
900BG/30	T91	1	flessometro	1692	T289
900/42	T91	1	miniseghetto	1725CR	T289
900/55	T91	1	oliatore in plastica	1755	T289
1260	T167	1	cutter con lama a settori	1771	T289
1260N	T167				
1262	T168				



5904VI/2T 1.810,00 059041164

Assortimento consigliato in abbinamento con C23ST - C24S da 7-8 cassette - C24SA da 7 8 cassette - C24SA-XL - C24SL - C24SL/CAB - C28 C37 da 7-8 cassette - C39 da 7-8 cassette - C39MD - C39SM - C59 - C55

5904VI/3T

assortimento di 142 utensili in termoformato rigido in ABS

Manutenzioni industriali



T05 T06 T31



T167 T202 T205



T80 T73 T68



T137 T153 T145 T146



T231 T297 T281



T285 VP6

26,5 kg

N. pezzi/Descrizione

- 16 chiavi combinate 6÷21 mm
- 5 chiavi combinate 22 - 24 - 27 - 30 - 32 mm
- 5 cacciaspina Ø 2 - 3 - 4 - 5 - 6 mm
- 1 bulino Ø 4 mm
- 12 chiavi a forchetta 6x7 - 8x9 - 10x11 - 12x13 - 14x15 - 16x17 - 18x19 - 20x22 - 21x23 - 24x26 - 27x29 - 30x32 mm
- 9 chiavi maschio esagonale piegate
○ 1,5 - 2 - 2,5 - 3 - 4 - 5 - 6 - 8 - 10 mm
- 9 giravite lama piatta ● 3x75 - 3,5x100 - 4x100 - 4x150 - 5,5x100 - 5,5x150 - 6,5x150 - 8x150 - 10x200 mm
- 2 giravite nano lama piatta ● 4x30 - 6,5x30 mm
- 6 giravite per viti con impronta a croce Phillips® ● PH0x60 - PH0x100 - PH1x80 - PH1x120 - PH2x100 - PH2x150 mm
- 7 chiave maschio per viti con impronta Torx®
○ T6-T7-T8-T9-T10-T15-T20
- 5 chiavi a bussola maschio esagonale 1/2"
○ 5 - 6 - 8 - 10 - 12 mm
- 1 prolunga - 1/2" 125 mm
- 1 prolunga - 1/2" 255 mm
- 1 snodo 1/2"
- 1 quadro maschio 1/2" con spina scorrevole
- 1 cricchetto reversibile 1/2" ⊕
- 19 chiavi a bussola esagonali 1/2"
○ 10÷24 - 26 - 27 - 30 - 32 mm
- 8 chiavi a tubo doppie poligonali 6x7 - 8x9 - 10x11 - 12x13 - 14x15 - 16x17 - 18x19 - 20x22 mm
- 1 spine di manovra per chiavi a tubo 1 - 2
- 1 spine di manovra per chiavi a tubo 1 - 2
- 6 chiavi a T maschio esagonale ○ 2,5 - 3 - 4 - 5 - 6 - 8 mm
- 1 pinza universale ■ 180 mm
- 1 pinza a becchi mezzotondi dritti ● 160 mm

Beta N.

TR

- 42NEW T05
- 42NEW T06
- 31 T31
- 32 T31
- 55 T31
- 96N/SC9 T31
- 1260 T167
- 1260N T167
- 1262 T202
- 1267TX T205
- 920ME T80
- 920/21 T80
- 920/22 T80
- 920/25 T80
- 920/42 T80
- 920/55 T80
- 920A T80
- 930 T73
- 940/1 T73
- 940/2 T73
- 951 T68
- 1150BM T137
- 1166BM T137

N. pezzi/Descrizione

- 1 tronchesi a grande effetto taglienti diagonali ⚡ 160 mm
- 1 pinze regolabili cerniera chiusa 250 mm
- 1 pinza autobloccante 240 mm
- 1 pinze becchi dritti per anelli elastici, per fori ○ 180 mm
- 1 pinze becchi piegati per anelli elastici, per fori ○ 170 mm
- 1 pinze becchi dritti per anelli elastici, per alberi ● 175 mm
- 1 pinze becchi piegati per anelli elastici, per alberi ● 175 mm
- 1 pinze becchi dritti per anelli elastici, per fori ○ 140 mm
- 1 pinze becchi piegati per anelli elastici, per fori ○ 225 mm
- 1 pinze becchi dritti per anelli elastici, per alberi ● 140 mm
- 1 pinze becchi piegati per anelli elastici, per alberi ● 225 mm
- 1 martello tipo tedesco 400 g
- 1 mazzuola con battentii in materiale plastico Ø 35 mm
- 1 lime a taglio mezzodolce 200 mm
- 1 lime a taglio mezzodolce 200 mm
- 1 lime a taglio mezzodolce 200 mm
- 1 calibro digitale a corsoio
- 1 riga flessibile graduata 300 mm
- 1 flessometro 5 m
- 1 rivettatrice 250 mm
- 100 rivetti 2,9x6 mm
- 100 rivetti 3,2x8 mm
- 100 rivetti 3,8x10 mm
- 100 rivetti 4x12 mm
- 100 rivetti 4,8x12 mm
- 1 cesoia a lame larghe diritte 250 mm
- 1 forbici per elettricisti lame dritte
- 1 seghetto
- (5) lame per seghetti
- 1 oliatore in plastica a pressione 200 cc termoformato vuoto

Beta N.

- 1084BM T137
- 1048 T153
- 1052 T153
- 1032 T145
- 1034 T145
- 1036 T145
- 1038 T145
- 1032 T146
- 1034 T146
- 1036 T146
- 1038 T146
- 1370 T231
- 1390 T231
- 1719BMA8/T T231
- 1719BMA8/P T231
- 1719BMA8/M T231
- 1651DGT T297
- 1682 T297
- 1691BM T297
- 1741B T281
- 1741RV...K T281
- 1741RV...K T281
- 1741RV...K T281
- 1741RV...K T281
- 1741RV...K T281
- 1112 T285
- 1128BM T285
- 1726 T285
- 1728BM T285
- 1753 T285
- VP6 VP6



5904VI/3T 2.095,00 059041168

Assortimento consigliato in abbinamento con C24S da 8 cassette - C24S/A da 8 cassette - C24SA-XL da 8-9 cassette
C28 - C37 da 8 cassette - C39 da 8 cassette - C39MD - C39SM - C55 - C59B

Manutenzioni industriali



33,5 kg

N. pezzi/Descrizione

Beta N. TR

N. pezzi/Descrizione

Beta N. TR

5	chiavi a bussola maschio esagonale 1/2" \odot 5 - 6 - 8 - 10 - 12 mm	920ME	T80	100	rivetti 4x12 mm	1741RV...K	T281
1	prolunga - 1/2" 125 mm	920/21	T80	100	rivetti 4,8x12 mm	1741RV...K	T281
1	prolunga - 1/2" 255 mm	920/22	T80	1	pinze regolabili cerniera chiusa 250 mm	1048	T153
1	snodo 1/2"	920/25	T80	1	pinza autobloccante 240 mm	1052	T153
1	quadro maschio 1/2" con spina scorrevole	920/42	T80	5	serie di 5 lime 200 mm	1719BMA...S5	T236
1	cricchetto reversibile 1/2" \oplus	920/55	T80	1	pinze becchi dritti per anelli elastici, per fori \odot 180 mm	1032	T145
19	chiavi a bussola esagonali 1/2" \odot 10÷24 - 26 - 27 - 30 - 32 mm	920A	T80	1	pinze becchi piegati per anelli elastici, per fori \odot 170 mm	1034	T145
16	chiavi combinate 6÷21 mm	42NEW	T05	1	pinze becchi dritti per anelli elastici, per alberi \bullet 175 mm	1036	T145
5	chiavi combinate 22 - 24 - 27 - 30 - 32 mm	42NEW	T06	1	pinze becchi piegati per anelli elastici, per alberi \bullet 175 mm	1038	T145
13	chiavi a bussola esagonali 1/4" \odot 4÷14 mm	900	T91	1	pinza universale \equiv 180 mm	1150BM	T137
6	chiavi a bussola maschio esagonale 1/4" \odot 2,5 - 3 - 4 - 5 - 6 - 8 mm	900ME	T91	1	pinza a becchi mezzotondi dritti \bullet 160 mm	1166BM	T137
1	prolunga - 1/4" 50 mm	900/20	T91	1	tronchesi a grande effetto taglienti diagonali \sphericalangle 160 mm	1084BM	T137
1	prolunga - 1/4" 150 mm	900/21	T91	5	cacciaspina \emptyset 2 - 3 - 4 - 5 - 6 mm	31	T31
1	quadro con impugnatura 1/4"	900BG/30	T91	1	bulino \emptyset 4 mm	32	T31
1	snodo 1/4"	900/25	T91	12	chiavi a forchetta 6x7 - 8x9 - 10x11 - 12x13 - 14x15 - 16x17 - 18x19 - 20x22 - 21x23 - 24x26 - 27x29 - 30x32 mm	55	T31
1	quadro scorrevole 1/4"	900/42	T91	9	chiavi maschio esagonale piegate \odot 1,5 - 2 - 2,5 - 3 - 4 - 5 - 6 - 8 - 10 mm	96N/SC9	T31
1	cricchetto reversibile 1/4" \oplus	900/55	T91	1	cesoia a lame larghe diritte 250 mm	1112	T285
6	chiavi a T maschio esagonale \odot 2,5 - 3 - 4 - 5 - 6 - 8 mm	951	T68	1	forbici per elettricisti lame dritte	1128BM	T285
7	chiavi poligonali curve 6x7-8x9-10x11-12x13-14x15-16x17-18x19 mm	90	T40	1	seghetto	1726	T285
5	chiavi poligonali curve 20x22 - 21x23 - 24x26 - 25x28 - 27x29 mm	90	T41	5	lame per seghetti	1728BM	T285
7	giravite lama piatta \bullet 2,5x50 - 3x75 - 3,5x100 - 4x125 - 5,5x100 - 5,5x150 - 6,5x150 mm	1260	T199	1	oliatore in plastica a pressione 200 cc	1753	T285
6	giravite per viti con impronta a croce Phillips® \oplus PH0x60 - PH0x100 - PH1x80 - PH1x120 - PH2x100 - PH2x150 mm	1262	T202	1	termoformato vuoto	VP5	VP5
3	giravite lama piatta \bullet 8x200 - 10x150 - 10x200 mm	1260	T201	1	giraschi regolabile M3+M12	435/1,5	T273
2	giravite nano lama piatta \bullet 4x30 - 6,5x30 mm	1260N	T201	1	giraschi regolabile M5+M21	435/3	T273
2	giravite per viti con impronta a croce Phillips® \oplus PH3x150 - PH4x200 mm	1262	T204	1	giraschi a cricchetto reversibile 2,0÷5,0 mm (M3+M8)	436/1	T273
2	giraviti nano Phillips® \oplus PH1x30 - PH2x30 mm	1262N	T204	1	giraschi a cricchetto reversibile 4,6÷8,0 mm (M5+M12)	436/2	T273
2	scalpelli piatti nervati 100 - 200 mm	35	T234	1	girafiliera 25,4 mm	444/1	T273
1	martello tipo tedesco 300 g	1370	T234	1	girafiliera 38,1 mm	444/2	T273
1	mazzuola con battenti in materiale plastico \emptyset 35 mm	1390	T234	1	contafiletto 0,25÷6 W 62÷4x1"	1707	T273
1	rivettatrice 250 mm	1741B	T281	26	maschi a mano passo grosso M3 - 4 - 5 - 6 - 7 - 8 - 9 - 10 - 12 - 14 - 16 - 18 - 20	430	T270
100	rivetti 2,9x6 mm	1741RV...K	T281	14	maschi a mano passo fine M6x0,75 - M8x1 - M10x1,25 - M12x1,5 - M14x1,5 - M16x1,5 - M18x1,5	433	T270
100	rivetti 3,2x8 mm	1741RV...K	T281	7	filiere tonde passo grosso M3 - 4 - 5 - 6 - 7 - 8 - 9	440	T270
100	rivetti 3,8x10 mm	1741RV...K	T281	6	filiere tonde passo grosso M10 - 12 - 14 - 16 - 18 - 20	440A	T270
				2	filiere tonde passo fine M6x0,75 - M8x0,75	441	T270
				5	filiere tonde passo fine M10x1,25 - M12x1,5 - M14x1,5 - M16x1,5 - M18x1,5	441A	T270



5908VI/2T 2.750,00 059081105

Assortimento consigliato in abbinamento con C28 - C24S/8 - C24SA/8 - C24SA-XL da 8 e 9 cassettei - C37/8 - C39/8 - C59B

Manutenzioni industriali



N. pezzi/Descrizione

6	cacciaspina Ø 2 - 3 - 4 - 5 - 6 - 8 mm	31/B6
1	bulino Ø 4 mm	32
2	scalpelli piatti nervati 125 - 250 mm	35
1	ugnetto nervato 200 mm	37
30	chiavi combinate 6-7-8-9-10-11-12-13-14-15-16-17-18-19-20-21-22-23-24-25-26-27-28-29-30-32-35-36-38-41 mm	42NEW
14	chiavi a forchetta 6x7 - 8x9 - 10x11 - 12x13 - 14x15 - 16x17 - 18x19 - 20x22 - 21x23 - 24x26 - 25x28 - 27x29 - 30x32 - 36x41 mm	55
13	chiavi poligonali curve 6x7+30x32 mm	90
14	chiavi maschio esagonale piegate 1,5 - 2 - 2,5 - 3 - 4 - 5 - 6 - 8 - 10 - 12 - 13 - 14 - 17 - 19 mm	96N
1	chiave regolabile a rullino 250 mm	111
1	giratubi modello americano 300 mm	362
25	punte elicoidali cilindriche, serie corta 1+13x0,5 mm	412/SP25
37	assortimento di maschi e filiere in acciaio HSS	447/C37
1	chiavi dinamometriche a scatto 1/2", 40+200 Nm	666N/20
1	quadro maschio a T snodato 1/2"	920/40
4	chiavi a bussola maschio esagonale 1/2" 10-12-14-17 mm	920ME
25	20 chiavi a bussola e 5 accessori	920A/C20X
17	assortimento di 12 chiavi a bussola e 5 accessori 3/4"	928A/C12
12	chiavi a pipa doppie esagonali - poligonali 8 - 10 - 11 - 13 - 14 - 17 - 19 - 22 - 24 - 27 - 30 - 32 mm	932
14	chiavi a T maschio esagonale 2+14 mm	951/S14
5	chiavi a T con maschio esagonale snodato 3 - 4 - 5 - 6 - 8 mm	953
3	pinze becchi diritti per anelli elastici, per fori 180 - 225 - 300 mm	1032
3	pinze becchi piegati per anelli elastici, per fori 170 - 210 - 290 mm	1034
3	pinze becchi diritti per anelli elastici, per alberi 140x1,3 - 175 - 225 mm	1036
3	pinze becchi piegati per anelli elastici, per alberi 135x1,3 - 175 - 220 mm	1038
2	pinze regolabili cerniera chiusa 250 - 300 mm	1048
1	pinza autobloccante a doppia regolazione	1051

Beta N. N. pezzi/Descrizione

1	tronchesi a grande effetto, a taglienti diagonali, finitura industriale 160 mm	1084GBM
1	tronchesi doppia leva taglio frontale 180 mm	1092V
1	cesoia a lame larghe diritte 300 mm	1112
1	cesoia a lame strette diritte 250 mm	1114
1	forbici per elettricisti lame diritte	1128BMX
1	pinze universali a grande effetto, finitura industriale 180 mm	1150GBM
1	pinze a becchi mezzotondi lunghissimi, diritti zigrinati, impugnatura bimateriale, finitura industriale 160 mm	1166GBM
1	pinze a becchi mezzotondi lunghissimi, piegati zigrinati, impugnatura bimateriale, finitura industriale 160 mm	1168GBM
9	giravite lama piatta 2,5x50 - 3x75 - 3,5x150 - 4x125 - 5,5x125 - 6,5x150 - 8x200 - 10x200 - 12x250 mm	1260
2	giravite nano lama piatta 4x30 - 6,5x30 mm	1260N
5	giravite per viti con impronta a croce Phillips PH0x100 - PH1x120 - PH2x150 - PH3x150 - PH4x200 mm	1262
2	giraviti nano Phillips PH1x30 - PH2x30 mm	1262N
7	chiave maschio per viti con impronta Torx T6 - T8 - T10 - T15 - T20 - T25 - T30	1267TX
2	martello tipo tedesco 300 - 600 g	1370
2	mazzuola con battenti in materiale plastico Ø 35 - 60 mm	1390
5	estrattori conici M3+M18	1430/S5
1	estrattore universale a due griffe 23+70 mm	1500N/1
1	estrattore universale a due griffe 23+100 mm	1500N/2
1	calibro a corsoio	1650
1	riga semirigida 300 mm	1683
1	punta per tracciare	1688A
1	flessometro 5 m	1692
1	spessimetro	1708/13
1	flessibile magnetico 1,8 kg	1712E/2
5	lime a taglio mezzodolce 200 mm	1719BMA8/S5
1	seghetto	1726BM
1	rivettatrice	1741B
1	oliatore in metallo a pressione 200 cc	1751



5910VI/3 5.700,00 059101044

Assortimento consigliato in abbinamento con C30S

5910VI/3T

assortimento di 261 utensili in termoformato rigido in ABS

Manutenzioni industriali



N. pezzi/Descrizione

16	chiavi combinate 6÷21 mm
5	chiavi combinate 22 - 24 - 27 - 30 - 32 mm
5	cacciapina Ø 2 - 3 - 4 - 5 - 6 mm
1	bulino Ø 4 mm
13	chiavi a forchetta 6x7 - 8x9 - 10x11 - 12x13 - 14x15 - 16x17 - 18x19 - 20x22 - 21x23 - 24x26 - 27x29 - 30x32 mm
9	chiavi maschio esagonale piegate 1,5 - 2 - 2,5 - 3 - 4 - 5 - 6 - 8 - 10 mm
5	chiavi poligonali curve 20x22 - 21x23 - 24x26 - 25x28 - 27x29 mm
7	chiavi poligonali curve 6x7 - 8x9 - 10x11 - 12x13 - 14x15 - 16x17 - 18x19 mm
5	chiavi a bussola maschio esagonale 1/2" Ø 5 - 6 - 8 - 10 - 12 mm
1	prolunga - 1/2" 125 mm
1	prolunga - 1/2" 255 mm
1	snodo 1/2"
1	quadro maschio 1/2" con spina scorrevole
1	cricchetto reversibile 1/2" ®
19	chiavi a bussola esagonali 1/2" Ø 10+24 - 26 - 27 - 30 - 32 mm
9	giravite lama piatta 3x75 - 3x100 - 4x100 - 4x150 - 5,5x100 - 5,5x150 - 6,5x150 - 8x150 - 10x200 mm
2	giravite nano lama piatta 4x30 - 6,5x30 mm
7	giravite per viti con impronta a croce Phillips® PH0x60 - PH0x100 - PH1x80 - PH1x120 - PH2x100 - PH2x150 - PH3x150 mm
2	giraviti nano Phillips® PH1x30 - PH2x30 mm
4	chiavi maschio esagonale piegate 13-14-17-19 mm
1	cesoia a lame larghe diritte 250 mm
1	forbici per elettricisti lame dritte
1	seghetto
(5)	lame per segchetti
1	oliatore in plastica a pressione 200 cc
1	pinza universale 180 mm
1	pinza a becchi mezzotondi dritti 160 mm
1	tronchese a grande effetto taglianti diagonali 160 mm
1	pinze becchi dritti per anelli elastici, per fori Ø 180 mm
1	pinze becchi piegati per anelli elastici, per fori Ø 170 mm

Beta N. N. pezzi/Descrizione

42NEW	1	pinze becchi dritti per anelli elastici, per alberi 175mm	1036
42NEW	1	pinze becchi piegati per anelli elastici, per alberi 175mm	1038
31	2	scalpelli piatti nervati 100 - 200 mm	35
32	1	martello tipo tedesco 300 g	1370
55	1	mazzuola con battenti in materiale plastico Ø 35 mm	1390
1	1	lime a taglio mezzodolce 200 mm	1719BMA8/S5
96N/SC9	4	chiavi combinate 35-36-38-41 mm	42
90	1	chiavi a forchetta 36x41 mm	55
90	1	chiave regolabile a rullino 250 mm	111
1	1	giratubi modello americano 300 mm	362
920ME	25	punte elicoidali cilindriche, serie corta	412/SP25
920/21	37	assortimento di maschi e filiere in acciaio HSS	447/C37
920/22	1	chiavi dinamometriche a scatto @ 200 Nm	666N/20
920/25	17	assortimento di 12 chiavi a bussola e 5 accessori 3/4"	928A/C12
920/42	14	chiavi a T maschio esagonale	951/S14
920/55	5	chiavi a T con maschio esagonale snodato Ø 3-4-5-6-8 mm	953
920A	1	pinze becchi dritti per anelli elastici, per fori Ø 300 mm	1032
1260	1	pinze becchi piegati per anelli elastici, per fori Ø 290 mm	1034
1	1	pinze becchi dritti per anelli elastici, per alberi 225 mm	1036
1260N	1	pinze becchi piegati per anelli elastici, per alberi 220 mm	1038
1262	1	pinze regolabili cerniera chiusa 300 mm	1048
1	1	pinza autobloccante a doppia regolazione	1051
96N	1	tronchese doppia leva taglio frontale 180 mm	1092V
1112	1	martello tipo tedesco 600 g	1370
1128BM	1	mazzuola con battenti in materiale plastico 60 mm	1390
1726	5	estrattori conici M3-M18	1430/S5
1728BM	1	estrattore universale a due griffe	1500/3
1753	1	calibro a corsoio	1650
1150BM	1	riga semirigida	1683
1166BM	1	punta per tracciare	1688
1084BM	1	flessometro 5 m	1692
1032	1	spessimetro	1708/13
1034	1	flessibile magnetico	1712E/2



5910VI/3T 4.870,00 059101063

Assortimento consigliato in abbinamento con C30S

5935VI/2MB

assortimento di 133 utensili per cassettera C35, in vassoio morbido in EVA

Manutenzioni industriali



MB12



MB37



MB44



MB55

N. pezzi/Descrizione	Beta N.	TR	N. pezzi/Descrizione	Beta N.	TR
21 chiavi combinate 6-7-8-9-10-11-12-13-14-15-16-17-18-19-20-21-22-24-27-30-32 mm	42NEW	MB12	1 quadro scorrevole 1/4"	900/42	MB37
8 chiavi a forchetta 6x7-8x9-10x11-12x13-14x15-16x17-18x19-20x22 mm	55	MB12	7 giravite lama piatta ● 2,5x50-3x75-3,5x100-4x100-5,5x125-6,5x150-8x200 mm	1260	MB44
1 pinze regolabili cerniera chiusa 250 mm	1048	MB12	2 giravite nano lama piatta ● 4x30-6,5x30 mm	1260N	MB44
19 chiavi a bussola esagonali 1/2" ○ 10-11-12-13-14-15-16-17-18-19-20-21-22-23-24-26-27-30-32 mm	920A	MB37	7 giravite per viti con impronta a croce Phillips®	1262	MB44
1 prolunga angolare - 1/2" 125 mm	920AN/125	MB37	● PH0x60-PH0x100-PH1x80-PH1x120-PH2x100-PH2x150-PH3x150 mm		
1 prolunga angolare - 1/2" 150 mm	920AN/250	MB37	2 giraviti nano Phillips® ● PH1x30-PH2x30 mm	1262N	MB44
1 snodo 1/2"	920/25	MB37	1 giravite cercafase ● 4x30-6,5x30 mm	1253	MB44
1 quadro maschio 1/2" con spina scorrevole	920/42	MB37	9 chiavi maschio esagonale piegate con estremità sferica ○	96BPC/SC9	MB44
1 cricchetto reversibile 1/2" ⊕	920/55	MB37	6 chiavi a T maschio esagonale ○ 2,5-3-4-5-6-8 mm	951	MB44
1 chiave regolabile a rullino 250 mm	111	MB37	5 cacciaspina Ø 2-3-4-5-6 mm	31	MB55
1 pinza autobloccante 240 mm	1052	MB37	1 bulino Ø 4 mm	32	MB55
1 tronchesi a grande effetto taglienti diagonali † 160 mm	1084BM	MB37	1 scalpelli piatti nervati 200 mm	35	MB55
1 pinza universale ≡ 180 mm	1150BM	MB37	1 cesoia a lame larghe diritte 250 mm	1112	MB55
1 pinza a becchi mezzotondi diritti ● 160 mm	1166BM	MB37	1 forbici per elettricisti lame diritte	1128BMX	MB55
1 pinze becchi diritti per anelli elastici, per fori ○ 180 mm	1032	MB37	1 martello tipo tedesco 500 g	1370	MB55
1 pinze becchi piegati per anelli elastici, per fori ○ 170 mm	1034	MB37	1 mazzuola con battenti in materiale plastico Ø 45 mm	1390	MB55
1 pinze becchi diritti per anelli elastici, per alberi ● 175 mm	1036	MB37	1 lima 200 mm	1719BMA...Q	MB55
1 pinze becchi piegati per anelli elastici, per alberi ● 175 mm	1038	MB37	1 lima 200 mm	1719BMA...T	MB55
13 chiavi a bussola esagonali 1/4" ○ 4-4,5-5-5,5-6-7-8-9-10-11-12-13-14 mm	900	MB37	1 lima 200 mm	1719BMA...P	MB55
1 prolunga - 1/4" 50 mm	900/20	MB37	1 lima 200 mm	1719BMA...M	MB55
1 prolunga - 1/4" 150 mm	900/21	MB37	1 lima 200 mm	1719BMA...R	MB55
1 snodo 1/4"	900/25	MB37	1 seghetto 440 mm	1726	MB55
1 quadro con impugnatura 1/4"	900BG/30	MB37			
1 cricchetto reversibile 1/4" ⊕	900/55	MB37			



5935VI/2MB 1.750,00 059351316

Assortimento consigliato in abbinamento con C35

Manutenzioni industriali



26 kg

N. pezzi/Descrizione

5	cacciaspina Ø 2-3-4-5-6 mm
1	bulino Ø 4 mm
2	scalpelli piatti nervati 200-250 mm
18	chiavi combinate 6÷14 - 16 - 17 - 18 - 19 - 21 - 22 - 24 - 27 - 30 mm
12	chiavi a forchetta 6x7 - 8x9 - 10x11 - 12x13 - 14x15 - 16x17 - 18x19 - 20x22 - 21x23 - 24x26 - 27x29 - 30x32 mm
12	chiavi maschio esagonale piegate Ø 2÷10 mm
1	chiave regolabile a rullino 250 mm
1	giratubi svedese 320 mm
20	chiavi a bussola esagonali 1/2" Ø 10÷24 - 26 - 27 - 28 - 30 - 32 mm
6	chiavi a bussola maschio esagonale 1/2" Ø 5 - 6 - 8 - 10 - 12 - 14 mm
1	prolunga - 1/2" 125 mm
1	prolunga - 1/2" 255 mm
1	snodo 1/2"
1	quadro maschio a T snodato 1/2"
1	quadro maschio 1/2" con spina scorrevole
1	cricchetto reversibile 1/2" ®
6	chiavi a T maschio esagonale Ø 2,5 - 3 - 4 - 5 - 6 - 8 mm
2	pinze becchi diritti per anelli elastici, per fori Ø 140 - 180 mm
1	pinze becchi piegati per anelli elastici, per fori Ø 170 mm
2	pinze becchi diritti per anelli elastici, per alberi ● 140x1,3 - 175 mm
1	pinze becchi piegati per anelli elastici, per alberi ● 175 mm
1	pinze regolabili cerniera chiusa 250 mm

Beta N. N. pezzi/Descrizione

31	1 pinza autobloccante 240 mm
32	1 tronchesi a grande effetto taglienti diagonali 160 mm
35	1 tronchesi doppia leva taglio frontale 180 mm
42NEW	1 cesoia a lame larghe diritte 250 mm
55	1 forbici per elettricisti lame diritte
	1 pinza universale 180 mm
96/SC12	1 pinza a becchi mezzotondi diritti ● 160 mm
111	1 giravite cercafase ●
374	2 giravite lama piatta ● 8x150 - 10x200 mm
920A	2 giravite nano lama piatta ● 4x30 - 6,5x30 mm
920ME	2 giravite per viti con impronta a croce Phillips®
920/21	● PH3x150 - PH4x200 mm
920/22	2 giraviti nano Phillips® ● PH1x30 - PH2x30 mm
920/25	8 giravite
920/40	2 martello tipo tedesco 300 - 500 g
920/42	1 mazzuola con battenti in materiale plastico Ø 45 mm
920/55	1 flessometro 5 m
951	1 flessibile magnetico 0,5 kg
1032	5 lime a taglio mezzodolce 200 mm
1034	1 seghetto
1036	1 oliatore in plastica a pressione 250 cc
1038	
1048	

Beta N.

1052
1084BM
1092V
1112
1128BMX
1150BM
1166BM
1253
1260
1260N
1262
1262N
1263/D8
1370
1390
1692
1712E/1
1719BMA8/S5
1726BM
1754



5954VI 1.950,00 059541053

Assortimento consigliato in abbinamento con C54S-C55C

Manutenzioni industriali



32 kg

N. pezzi/Descrizione

6	cacciaspina Ø 2 - 3 - 4 - 5 - 6 - 8 mm
6	2 punzoni, 1 bulino, 3 scalpelli con supporto
18	chiavi combinate 6-7-8-10-11-12-13-14-15-16-17-19-21-22-24-27-30-32 mm
12	chiavi a forchetta 6x7 ÷ 30x32 mm
8	chiavi maschio esagonale con impugnatura 2 - 2,5 - 3 - 4 - 5 - 6 - 8 - 10 mm
8	chiavi maschio piegate per viti con impronta Torx®
	⊕ T9 - T10 - T15 - T20 - T25 - T27 - T30 - T40
1	chiave regolabile a rullino 250 mm
13	chiavi a bussola poligonali 1/2" con guida ⌀ 10÷22 mm
8	chiavi a bussola poligonali 1/2" con guida ⌀ 23÷32 mm
4	chiavi a bussola a giravite lama piatta 1/2" ⌀ 1,2x6,5 - 1,2x8 - 1,6x9 - 2x12 mm
3	chiavi a bussola a giravite lama Phillips® 1/2" ⊕ PH2 - 3 - 4
1	prolunga - 1/2" 125 mm
1	prolunga - 1/2" 255 mm
1	snodo 1/2"
1	quadro maschio 1/2" con spina scorrevole
1	cricchetto reversibile 1/2" ⊕
1	leva con estremità a punta e piatta curva
2	pinze becchi dritti per anelli elastici, per fori ⌀ 140 - 180 mm
2	pinze becchi piegati per anelli elastici, per fori ⌀ 130 - 170 mm
2	pinze becchi dritti per anelli elastici, per alberi ⌀ 140 - 175 mm
2	pinze becchi piegati per anelli elastici, per alberi ⌀ 135 - 175 mm
1	pinze regolabili cerniera chiusa 250 mm
1	pinza autobloccante a doppia regolazione
1	tronchesi a grande effetto taglienti diagonali ⚡ 160 mm
1	tronchesi doppia leva taglio frontale ⚡ 180 mm
1	cesoia a lame larghe diritte 250 mm

Beta N.

31/SP6
38/SP6
42NEW
55/S12X
96T/S8
97TX/SC8
111
920B/SB13
920B/SB8
920LP
920PH
920/21
920/22
920/25
920/42
920/55
963
1032
1034
1036
1038
1048
1051
1084BM
1092V
1112

N. pezzi/Descrizione

1	cesoia a lame strette diritte 250 mm	1114
1	forbici per elettricisti lame diritte	1128BMX
1	pinza universale = 180 mm	1150BM
1	pinza a becchi mezzotondi dritti ⌀ 160 mm	1166BM
1	pinza a becchi mezzotondi piegati ⌀ 160 mm	1168BM
7	giravite lama piatta ⌀ 2,5x50 - 3x75 - 4x100 - 5,5x125 - 6,5x150 - 8x200 - 10x200 mm	1260
4	giravite per viti con impronta a croce Phillips® ⊕ PH0x60 - PH1x80 - PH2x100 - PH3x150 mm	1262
3	martello tipo tedesco 300 - 600 - 1000 g	1370
1	mazzuola con battenti in materiale plastico Ø 35 mm	1390
1	flessometro 5 m	1692
1	flessibile magnetico 1,8 kg	1712E/2
1	raschietto a due taglienti 200 mm	1717A
1	raschietto a tre taglienti 200 mm	1717B
5	lime a taglio mezzodolce 200 mm	1719BMA8/S5
1	seghetto	1725
1	oliatore in metallo a pressione 200 cc	1751
1	scalpelli piatti nervati 200 mm	35
1	ugnetto nervato 200 mm	37
11	chiavi a pipa doppie esagonali - poligonali 8 - 10 - 11 - 12 - 13 - 14 - 16 - 17 - 19 - 22 - 24 mm	932
1	pinza autobloccante 240 mm	1052
1	pinza autobloccante 280 mm	1060
1	pinza autobloccante 290 mm	1062
1	mazzuola antirimbalo Ø 50 mm	1392
1	estrattore universale a due griffe 25÷130 mm	1500N/2
1	calibro a corsoio	1650
1	riga semirigida 300 mm	1683
1	punta per tracciare	1688A
1	spessimetro	1708/13
1	coltello a serramanico	1777BM
1	cutter con lama a settori 170 mm	1771BM
1	tronchesi a taglienti diagonali ⚡ 160 mm	1082BM



5957VI 2.830,00 059571005

Assortimento consigliato in abbinamento con C57SA - C57SB

5904VU/1M

assortimento di 91 utensili in vassoio morbido in EVA

Universali



13,5 kg

N. pezzi/Descrizione

- 16 chiavi combinate 6÷21 mm
- 8 chiavi a forchetta 6x7 - 8x9 - 10x11 - 12x13 - 14x15 - 16x17 - 18x19 - 20x22 mm
- 9 chiavi maschio esagonale piegate \odot 1,5 - 2 - 2,5 - 3 - 4 - 5 - 6 - 8 - 10 mm
- 7 giravite lama piatta \bullet 2,5x50 - 3x75 - 3,5x100 - 4x125 - 5,5x100 - 5,5x150 - 6,5x150 mm
- 6 giravite per viti con impronta a croce Phillips® \oplus PH0x60 - PH0x100 - PH1x80 - PH1x120 - PH2x100 - PH2x150 mm
- 8 chiavi maschio esagonale con impugnatura \odot 2-2,5-3-4-5-6-7-8 mm
- 1 prolunga angolare - 1/2" 125 mm
- 1 prolunga angolare - 1/2" 250 mm
- 1 snodo 1/2"
- 1 quadro maschio 1/2" con spina scorrevole
- 1 cricchetto reversibile 1/2" \otimes
- 19 chiavi a bussola esagonali 1/2" \odot 10÷24 - 26 - 27 - 30 - 32 mm

Beta N.	TR
42NEW	M05
55	M33
96/SC9	M33
1260	M199
1262	M202
96T	M50
920AN/125	M83
920AN/250	M83
920/25	M83
920/42	M83
920/55	M83
920A	M83

N. pezzi/Descrizione

- 1 tronchesi a grande effetto taglienti diagonali \leq 160 mm
- 1 pinza universale \equiv 180 mm
- 1 pinza a becchi mezzotondi dritti \bullet 160 mm
- 1 pinze regolabili cerniera chiusa 250 mm
- 1 pinza autobloccante 240 mm
- 2 scalpelli piatti nervati 100 - 200 mm
- 1 martello tipo tedesco 300 g
- 1 mazzuola con battenti in materiale plastico \varnothing 35 mm
- 1 pinze becchi dritti per anelli elastici, per fori \odot 180 mm
- 1 pinze becchi piegati per anelli elastici, per fori \odot 170 mm
- 1 pinze becchi dritti per anelli elastici, per alberi \bullet 175 mm
- 1 pinze becchi piegati per anelli elastici, per alberi \bullet 175 mm

Beta N.	TR
1084	M137
1150	M137
1166	M137
1048	M153
1052	M153
35	M234
1370	M234
1390	M234
1032	M145
1034	M145
1036	M145
1038	M145



5904VU/1M 1.108,00 059041201

Assortimento consigliato in abbinamento con C23ST - C24S - C24SA - C24SA-XL - C24SL - C24SL/CAB - C28 C37 - C39 - C39T - C39SM - C39MD - C55 - C59

5904VU/2M

assortimento di 151 utensili in vassoio morbido in EVA

Universali



M05 M33 M199 M202



M50 M83



M137 M153 M237 M145



M204 M289 M85 M236

20 kg

N. pezzi/Descrizione

- 16 chiavi combinate 6÷21 mm
- 8 chiavi a forchetta 6x7 - 8x9 - 10x11 - 12x13 - 14x15 - 16x17 - 18x19 - 20x22 mm
- 9 chiavi maschio esagonale piegate
 ○ 1,5 - 2 - 2,5 - 3 - 4 - 5 - 6 - 8 - 10 mm
- 7 giravite lama piatta ● 2,5x50 - 3x75 - 3,5x100 - 4x125 - 5,5x100 - 5,5x150 - 6,5x150 mm
- 6 giravite per viti con impronta a croce Phillips® ● PH0x60 - PH0x100 - PH1x80 - PH1x120 - PH2x100 - PH2x150 mm
- 8 chiavi maschio esagonale con impugnatura
 ○ 2-2,5-3-4-5-6-7-8 mm
- 1 prolunga angolare - 1/2" 125 mm
- 1 prolunga angolare - 1/2" 250 mm
- 1 snodo 1/2"
- 1 quadro maschio 1/2" con spina scorrevole
- 1 cricchetto reversibile 1/2" ⊕
- 19 chiavi a bussola esagonali 1/2"
 ○ 10÷24 - 26 - 27 - 30 - 32 mm
- 1 tronchesi a grande effetto taglienti diagonali † 160 mm
- 1 pinza universale = 180 mm
- 1 pinza a becchi mezzotondi diritti ● 160 mm
- 1 pinze regolabili cerniera chiusa 250 mm
- 1 pinza autobloccante 240 mm
- 2 scalpelli piatti nervati 100 - 200 mm
- 1 martello tipo tedesco 300 g
- 1 mazzuola Ø 35 mm
- 1 pinze becchi diritti per anelli elastici, per fori ○ 180 mm

Beta N. TR

- 42NEW M05
- 55 M33
- 96/SC9 M33
- 1260 M199
- 1262 M202
- 96T M50
- 920AN/125 M83
- 920AN/250 M83
- 920/25 M83
- 920/42 M83
- 920/55 M83
- 920A M83
- 1084 M137
- 1150 M137
- 1166 M137
- 1048 M153
- 1052 M153
- 35 M237
- 1370T M237
- 1390N M237
- 1032 M145

N. pezzi/Descrizione

- 1 pinze becchi piegati per anelli elastici, per fori ○ 170 mm
- 1 pinze becchi diritti per anelli elastici, per alberi ● 175 mm
- 1 pinze becchi piegati per anelli elastici, per alberi ● 175 mm
- 6 chiave maschio per viti con impronta Torx®
 ○ T8-T10-T15-T20-T25-T30
- 1 flessometro 5 m
- 1 miniseghetto
- 1 oliatore in plastica 30 cc
- 1 cutter con lama a settori
- 5 inserti colorati per avvitatori per viti a testa con intaglio ●
 0,5x3 - 0,6x4,5 - 0,8x5,5 - 1x5,5 - 1,2x6,5 mm
- 8 inserti colorati maschio esagonale per avvitatori ○ 2 - 2,5 - 3 - 4 - 5 - 6 - 8 - 10 mm
- 5 inserti colorati per avvitatori per viti con impronta a croce Phillips® ● PH0 - PH1 - PH2 - PH3 - PH4
- 4 inserti colorati per avvitatori per viti con impronta a croce Pozidriv® - Supadriv® ● PZ1 - PZ2 - PZ3 - PZ4
- 11 inserti colorati per avvitatori per viti con impronta Torx® ○ T6-T7-T8-T9-T10-T15-T20-T25-T27-T30-T40
- 8 inserti colorati per avvitatori per viti con impronta Tamper Resistant Torx® ● T9-T10-T15-T20-T25-T27-T30-T40
- 1 portainseri a sgancio rapido con impugnatura 230 mm
- 1 cricchetto reversibile portainseri 100 mm
- 5 lime a taglio mezzodolce 200 mm
- 1 raccordi per avvitatori
- 1 prolunga portainseri magnetica

Beta N. TR

- 1034 M145
- 1036 M145
- 1038 M145
- 1267TX M204
- 1692 M289
- 1725CR M289
- 1755 M289
- 1771 M289
- 860LP M85
- 860PE M85
- 860PH M85
- 860PZ M85
- 860TX M85
- 860RTX M85
- 851SR M85
- 860/55 M85
- 1719BMA8/S5 M236
- 892/0 M85
- 882P M85

5904VU/2M 1.465,00 059041202

Assortimento consigliato in abbinamento con C23ST - C24S - C24SA - C24SA-XL - C24SL - C24SL/CAB - C28 - C37 - C39 - C39SM - C39MD - C39T - C55 - C59

5904VU/2T

assortimento di 104 utensili in termoformato rigido in ABS

Universali



T199 T202 T83



T145 T153 T138 T234



T68 T33 T05 T06



T284

N. pezzi/Descrizione

7	giravite lama piatta	2,5x50 - 3x75 - 3,5x100 - 4x125 5,5x100 - 5,5x150 - 6,5x150 mm
6	giravite per viti con impronta a croce Phillips®	PH0x60 - PH0x100 - PH1x80 - PH1x120 - PH2x100 - PH2x150 mm
19	chiavi a bussola esagonali 1/2"	10-11-12-13-14-15-16-17-18-19-20-21-22-23-24-26-27-30-32 mm
1	prolunga - 1/2"	125 mm
1	prolunga - 1/2"	255 mm
1	snodo 1/2"	
1	quadro maschio 1/2"	con spina scorrevole 305 mm
1	cricchetto reversibile 1/2"	
1	pinze becchi dritti per anelli elastici, per fori	180 mm
1	pinze becchi piegati per anelli elastici, per fori	170 mm
1	pinze becchi dritti per anelli elastici, per alberi	175 mm
1	pinze becchi piegati per anelli elastici, per alberi	175 mm
1	pinze regolabili cerniera chiusa	250 mm
1	pinza autobloccante	240 mm
1	tronchesi a grande effetto taglienti diagonali	160 mm
1	pinza universale	180 mm
1	pinza a becchi mezzotondi dritti	160 mm

Beta N. TR

1260	T199
1262	T202
920A	T83
920/21	T83
920/22	T83
920/25	T83
920/42	T83
920/55	T83
1032	T145
1034	T145
1036	T145
1038	T145
1048	T153
1052	T153
1084	T138
1150	T138
1166	T138

N. pezzi/Descrizione

2	scalpelli piatti nervati 100-200 mm	
1	martello tipo tedesco 300 g	
1	mazuola con battenti in materiale plastico Ø 35 mm	
6	chiavi a T maschio esagonale	2,5-3-4-5-6-8 mm
8	chiavi a forchetta 6x7-8x9-10x11-12x13-14x15 16x17-18x19-20x22 mm	
9	chiavi maschio esagonale piegate	1,5+10 mm
16	chiavi combinate 6-7-8-9-10-11-12-13-14-15-16-17 18-19-20-21 mm	
5	chiavi combinate 22-24-27-30-32 mm	
1	forbici per elettricisti lame diritte	
1	forbici multiuso	
1	lima 200 mm	
1	lima 200 mm	
1	lima 200 mm	
1	lima 200 mm	
1	lima 200 mm	
1	seghetto	
1	lame per seghetti	
1	cutter con lama a settori 170 mm	
1	coltello a serramanico 185 mm	

Beta N. TR

35	T234
1370	T234
1390	T234
951	T68
55	T33
96/SC9	T33
42NEW	T05
42NEW	T06
1128BMX	T284
1130BMX	T284
1719BMA...Q	T284
1719BMA...P	T284
1719BMA...T	T284
1719BMA...M	T284
1719BMA...R	T284
1726BM	T284
1728BM	T284
1771BM	T284
1778	T284



5904VU/2T 1.385,00 059041070

Assortimento consigliato in abbinamento con C23ST - C24S - C24SA - C24SA-XL - C24SL - C24SL/CAB - C28 - C37 - C39 - C39SM - C39MD - C39T - C55 - C59

5904VU/3T

assortimento di 146 utensili in termoformato rigido in ABS

Universali



T05 T06 T31



T52 T55 T80



T91 T145 T138 T153



T198 T205 T234 T236

23 kg

N. pezzi/Descrizione

N. pezzi/Descrizione	Beta N.	TR
16 chiavi combinate 6÷21 mm	42NEW	T05
5 chiavi combinate 22 - 24 - 27 - 30 - 32 mm	42NEW	T06
5 cacciaspina Ø 2 - 3 - 4 - 5 - 6 mm	31	T31
1 bullino Ø 4 mm	32	T31
12 chiavi a forchetta 6x7 - 8x9 - 10x11 - 12x13 - 14x15 - 16x17 - 18x19 - 20x22 - 21x23 - 24x26 - 27x29 - 30x32 mm	55	T31
9 chiavi maschio esagonale piegate Ø 1,5 - 2 - 2,5 - 3 - 4 - 5 - 6 - 8 - 10 mm	96N/SC9	T31
6 chiavi maschio esagonale con impugnatura Ø 2 - 2,5 - 3 - 4 - 5 - 6 mm	96T	T52
6 chiavi maschio con impugnatura per viti con impronta Torx® Ø T10-T15-T20-T25-T27-T30	97TTX	T55
5 chiavi a bussola maschio esagonale 1/2" Ø 5 - 6 - 8 - 10 - 12 mm	920ME	T80
1 prolunga - 1/2" 125 mm	920/21	T80
1 prolunga - 1/2" 255 mm	920/22	T80
1 snodo 1/2"	920/25	T80
1 quadro maschio 1/2" con spina scorrevole	920/42	T80
1 cricchetto reversibile 1/2" Ⓞ	920/55	T80
19 chiavi a bussola esagonali 1/2" Ø 10÷24 - 26 - 27 - 30 - 32 mm	920A	T80
13 chiavi a bussola esagonali 1/4" Ø 4-4,5-5-5,5-6-7-8-9-10-11-12-13-14 mm	900	T91
6 chiavi a bussola maschio esagonale 1/4" Ø 2,5-3-4-5-6-8 mm	900ME	T91
1 prolunga - 1/4" 50 mm	900/20	T91
1 prolunga - 1/4" 150 mm	900/21	T91
1 snodo 1/4"	900/25	T91
1 quadro con impugnatura 1/4"	900BG/30	T91
1 quadro scorrevole 1/4" 115 mm	900/42	T91

N. pezzi/Descrizione

N. pezzi/Descrizione	Beta N.	TR
1 cricchetto reversibile 1/4" Ⓞ	900/55	T91
1 pinze becchi dritti per anelli elastici, per fori Ø 180 mm	1032	T145
1 pinze becchi piegati per anelli elastici, per fori Ø 170 mm	1034	T145
1 pinze becchi dritti per anelli elastici, per alberi Ø 175 mm	1036	T145
1 pinze becchi piegati per anelli elastici, per alberi Ø 175 mm	1038	T145
1 pinza universale = 180 mm	1150	T138
1 pinza a becchi mezzotondi dritti Ø 160 mm	1166	T138
1 tronchesi a grande effetto taglienti diagonali 160 mm	1084	T138
1 pinze regolabili cerniera chiusa 250 mm	1048	T153
1 pinza autobloccante 240 mm	1052	T153
4 giravite lama piatta Ø 3x75 - 4x100 - 5,5x150 - 6,5x150 mm	1260	T198
3 giravite per viti con impronta a croce Pozidriv®-Supadriv® Ⓞ PZ0 - PZ1 - PZ2	1269PZ	T198
7 chiave maschio per viti con impronta Torx® Ⓞ T6-T7-T8-T9-T10-T15-T20	1267TX	T205
2 scalpelli piatti nervati 100 - 200 mm	35	T234
1 martello tipo tedesco 300 g	1370	T234
1 mazzuola con battenti in materiale plastico Ø 35 mm	1390	T234
5 lime a taglio mezzodolce 200 mm	1719BMA8/	T236
	S5	



5904VU/3T 1.685,00 059041203

Assortimento consigliato in abbinamento con C24S - C24SA - C24SA-XL - C24SL - C24SL/CAB - C37 - C39 - C39T - C39SM - C39MD - C55 - C59

5904VU/4T

assortimento di 197 utensili in termoformato rigido in ABS

Universali



T01

T83



T91

T156

T40

T211



T213

T216

T234

T259



N. pezzi/Descrizione

Beta N. TR

N. pezzi/Descrizione

Beta N. TR

1	punzoni Ø 4 mm	30		1	prolunga - 1/4" 150 mm	900/21	T91
1	cacciaspina Ø 4 mm	31		1	snodo 1/4"	900/25	T91
1	bulino Ø 4 mm	32		1	quadro con impugnatura 1/4"	900BG/30	T91
54	assortimento di 52 inserti con attacco esagonale 10 mm e 2 accessori	867/C52		1	quadro scorrevole 1/4" 115 mm	900/42	T91
17	chiavi combinate 6-7-8-10-11-12-13-14-16-17-18-19-21-22-24-27-30 mm	42NEW	T01	1	cricchetto reversibile 1/4" Ⓢ	900/55	T91
7	chiavi poligonali curve 6x7-8x9-10x11-12x13-14x15-16x17-18x19 mm	90	T40	1	tronchesi a taglienti diagonali $\leq 160\text{ mm}$	1082	T156
19	chiavi a bussola esagonali 1/2" Ⓞ 10-11-12-13-14-15-16-17-18-19-20-21-22-23-24-26-27-30-32 mm	920A	T83	1	pinza universale = 180 mm	1150	T156
1	prolunga - 1/2" 125 mm	920/21	T83	1	pinze regolabili cerniera chiusa 250 mm	1048	T156
1	prolunga - 1/2" 250 mm	920/22	T83	7	giravite lama piatta Ⓢ 2,5x50 - 3x75 - 3,5x100 - 4x125 - 5,5x100 - 5,5x150 - 6,5x150 mm	1201E	T211
1	snodo 1/2"	920/25	T83	6	giravite Phillips® Ⓢ PH0x60 - PH1x80 - PH1x120 - PH2x100 - PH2x150 - PH3x150 mm	1202E	T213
1	quadro maschio 1/2" con spina scorrevole 305 mm	920/42	T83	7	chiavi maschio con impugnatura per viti con impronta Torx® Ⓢ T6-T7-T8-T9-T10-T15-T20	1207E/TX	T216
1	cricchetto reversibile 1/2" Ⓢ	920/55	T83	2	scalpelli piatti nervati 100-200 mm	35	T234
13	chiavi a bussola esagonali 1/4" Ⓞ 4-4,5-5-5,5-6-7-8-9-10-11-12-13-14 mm	900	T91	1	martello tipo tedesco 300 g	1370	T234
6	chiavi a bussola maschio esagonale 1/4" Ⓞ 2,5-3-4-5-6-8 mm	900ME	T91	1	mazzuola con battenti in materiale plastico Ø 35 mm	1390	T234
1	prolunga - 1/4" 50 mm	900/20	T91	7	chiavi maschio esagonale piegate con estremità sferica Ⓞ 2,5-3-4-5-6-8-10 mm	96BP	T259

1	prolunga - 1/4" 150 mm	900/21	T91
1	snodo 1/4"	900/25	T91
1	quadro con impugnatura 1/4"	900BG/30	T91
1	quadro scorrevole 1/4" 115 mm	900/42	T91
1	cricchetto reversibile 1/4" Ⓢ	900/55	T91
1	tronchesi a taglienti diagonali $\leq 160\text{ mm}$	1082	T156
1	pinza universale = 180 mm	1150	T156
1	pinze regolabili cerniera chiusa 250 mm	1048	T156
7	giravite lama piatta Ⓢ 2,5x50 - 3x75 - 3,5x100 - 4x125 - 5,5x100 - 5,5x150 - 6,5x150 mm	1201E	T211
6	giravite Phillips® Ⓢ PH0x60 - PH1x80 - PH1x120 - PH2x100 - PH2x150 - PH3x150 mm	1202E	T213
7	chiavi maschio con impugnatura per viti con impronta Torx® Ⓢ T6-T7-T8-T9-T10-T15-T20	1207E/TX	T216
2	scalpelli piatti nervati 100-200 mm	35	T234
1	martello tipo tedesco 300 g	1370	T234
1	mazzuola con battenti in materiale plastico Ø 35 mm	1390	T234
7	chiavi maschio esagonale piegate con estremità sferica Ⓞ 2,5-3-4-5-6-8-10 mm	96BP	T259
1	chiavi maschio esagonale piegate Ⓞ 12 mm	96N	T259
31	inserti colorati con portainseri magnetico in astuccio tascabile	860MIX/A31	T259
1	bussola portainseri	895/1	T259

5904VU/4T 1.315,00 059241100

Assortimento consigliato in abbinamento con C23ST - C24S - C24SA - C24SA-XL - C24SL - C24SL/CAB - C37 - C39 - C39T - C39SM - C39MD - RSC55 - C59

5908VU/2T

assortimento di 161 utensili in termoformato rigido in ABS

Universali



T05 T06 T31



T40 T52 T55 T91



T82 T138 T153



T145 T170 T171 T172



T173 T234 T236 VP4

N. pezzi/Descrizione

N. pezzi/Descrizione	Beta N.	TR
16 chiavi combinate 6÷21 mm	42NEW	T05
5 chiavi combinate 22 - 24 - 27 - 30 - 32 mm	42NEW	T06
5 cacciaspina Ø 2 - 3 - 4 - 5 - 6 mm	31	T31
1 bulino Ø 4 mm	32	T31
12 chiavi a forchetta 6x7 - 8x9 - 10x11 - 12x13 - 14x15 - 16x17 - 18x19 - 20x22 - 21x23 - 24x26 - 27x29 - 30x32 mm	55	T31
9 chiavi maschio esagonale piegate ○ 1,5 - 2 - 2,5 - 3 - 4 - 5 - 6 - 8 - 10 mm	96N/SC9	T31
7 chiavi poligonali curve 6x7-8x9-10x11-12x13-14x15-16x17-18x19 mm	90	T40
6 chiavi maschio esagonale con impugnatura ○ 2-2,5-3-4-5-6 mm	96T	T52
6 chiavi maschio con impugnatura per viti con impronta Torx® ○ T10-T15-T20-T25-T27-T30	97TTX	T55
19 chiavi a bussola esagonali 1/2" ○ 10-11-12-13-14-15-16-17-18-19-20-21-22-23-24-26-27-30-32 mm	920A	T82
5 chiavi a bussola maschio esagonale 1/2" ○ 5-6-8-10-12 mm	920ME	T82
1 prolunga angolare - 1/2" 125 mm	920AN/125	T82
1 prolunga angolare - 1/2" 250 mm	920AN/250	T82
1 snodo 1/2"	920/25	T82
1 quadro maschio 1/2" con spina scorrevole 305 mm	920/42	T82
1 cricchetto reversibile 1/2" Ⓞ	920/55	T82
13 chiavi a bussola esagonali 1/4" ○ 4-4,5-5-5,5-6-7-8-9-10-11-12-13-14 mm	900	T91
6 chiavi a bussola maschio esagonale 1/4" ○ 2,5-3-4-5-6-8 mm	900ME	T91
1 prolunga - 1/4" 50 mm	900/20	T91
1 prolunga - 1/4" 150 mm	900/21	T91
1 snodo 1/4"	900/25	T91
1 quadro con impugnatura 1/4"	900BG/30	T91
1 quadro scorrevole 1/4" 115 mm	900/42	T91
1 cricchetto reversibile 1/4" Ⓞ	900/55	T91
1 tronchesi a grande effetto taglienti diagonali 160 mm	1084	T138
1 pinza universale 180 mm	1150	T138
1 pinza a becchi mezzotondi dritti 160 mm	1166	T138

N. pezzi/Descrizione

N. pezzi/Descrizione	Beta N.	TR
1 pinze becchi dritti per anelli elastici, per fori ○ 180 mm	1032	T145
1 pinze becchi piegati per anelli elastici, per fori ○ 170 mm	1034	T145
1 pinze becchi dritti per anelli elastici, per alberi ● 175 mm	1036	T145
1 pinze becchi piegati per anelli elastici, per alberi ● 175 mm	1038	T145
1 pinze regolabili cerniera chiusa 250 mm	1048	T153
1 pinza autobloccante 240 mm	1052	T153
7 giravite lama piatta ● 2,5x50-3x75-3,5x100-4x125-5,5x100-5,5x150-6,5x150 mm	1290	T170
3 giravite lama piatta ● 8x150-8x200-10x200 mm	1290	T171
2 giravite nano lama piatta ● 4x30-6,5x30 mm	1290N	T171
6 giravite Phillips® ● PH0x60-PH0x100-PH1x80-PH1x120-PH2x100-PH2x150 mm	1292	T172
2 giravite Phillips® ● PH3x150-PH4x200 mm	1292	T173
2 giravite nano Phillips® ● PH1x30-PH2x30 mm	1292N	T173
2 scalpelli piatti nervati 100-200 mm	35	T234
1 martello tipo tedesco 300 g	1370	T234
1 mazzuola con battenti in materiale plastico Ø 35 mm	1390	T234
1 lima 200 mm	1719BMA...Q	T236
1 lima 200 mm	1719BMA...T	T236
1 lima 200 mm	1719BMA...P	T236
1 lima 200 mm	1719BMA...M	T236
1 lima 200 mm	1719BMA...R	T236
1 termoformato rigido in ABS		VP4



5908VU/2T 1.905,00 059081136

Assortimento consigliato in abbinamento con C23ST - C24S da 6-7-8 cassette - C24SA - C24SA-XL - C24SL - C24SL/CAB - C28 C37 da 6-7-8 cassette - C39 da 6-7-8 cassette - C39MD - C39SM - C59 - RSC55

5914VU/M

Assortimento di 109 utensili per trolley C14, in vassoio morbido in EVA

Universali



MC T1



MC T2



MC T3

N. pezzi/Descrizione	Beta N.	TR	N. pezzi/Descrizione	Beta N.	TR
31 inserti colorati con portainseriti magnetico in astuccio tascabile ● ○ ⊕ ⊕ ⊕ ⊕	860MIX/A31	MCT1	9 chiavi maschio esagonale piegate ○	96/SC9	MCT2
1 bussola portainseriti	895/1	MCT1	1 chiave regolabile a rullino 250 mm	111	MCT2
13 chiavi a bussola esagonali 1/4" ○ 4-4,5-5-5,6-7-8-9-10-11-12-13-14 mm	900	MCT1	1 forbici per elettricisti lame diritte	1128BMX	MCT2
1 prolunga - 1/4" 150 mm	900/...	MCT1	1 flessometro 5 mt	1692/5	MCT2
1 snodo 1/4"	900/25	MCT1	1 cutter con lama a settori	1771	MCT2
1 quadro maschio 1/4"	900BG/30C	MCT1	1 pinze regolabili cerniera chiusa 250 mm	1048	MCT3
1 quadro scorrevole 1/4"	900/42	MCT1	1 tronchesi a taglienti diagonali < 160 mm	1082BM	MCT3
1 cricchetto reversibile 1/4" ⊕	900/55	MCT1	1 pinza universale = 180 mm	1150BM	MCT3
16 chiavi a bussola esagonali 1/2" ○ 10-11-12-13-14-15-16-17-18-19-21-22-24-27-30-32 mm	920A	MCT1	1 pinza a becchi mezzotondi dritti ● 160 mm	1166BM	MCT3
1 snodo 1/2"	920/25	MCT1	3 giravite lama piatta ● 3,5x100-5,5x125-6,5x150 mm	1260	MCT3
1 prolunga angolare - 1/2"	920AN/125	MCT1	3 giravite per viti con impronta a croce Phillips® ⊕ PHx60-PH1x80-PH3x100 mm	1262	MCT3
1 quadro maschio 1/2" con spina scorrevole	920/42	MCT1			
1 cricchetto reversibile 1/2" ⊕	920/55	MCT1			
16 chiavi combinate 6-7-8-9-10-11-12-13-14-15-16-17-18-19-21-22 mm	42NEW	MCT2			



5914VU/M 912,00 059140112

Assortimento consigliato in abbinamento con C14

Universali



M01



M100



M213



M33 M86 M136 M234

N. pezzi/Descrizione	Beta N.	TR	N. pezzi/Descrizione	Beta N.	TR
22 chiavi combinate 6-7-8-9-10-11-12-13-14-15-16-17-18-19-20-21-22-24-27-30-32-36 mm	42NEW	M01	1 prolunga - 1/4" 150 mm	900/21	M100
8 chiavi a forchetta 6x7-8x9-10x11-12x13-14x15-16x17-18x19-20x22 mm	55	M33	1 snodo 1/4"	900/25	M100
9 chiavi maschio esagonale piegate Ø 1,5÷10 mm	96/SC9	M33	1 quadro con impugnatura 1/4"	900BG/30	M100
7 inserti maschio esagonale Ø 4-5-6-7-8-10-12 mm	867PE	M86	1 quadro scorrevole 1/4"	900/42	M100
7 inserti maschio esagonale Ø 4-5-6-7-8-10-12 mm	867PE/L	M86	1 cricchetto reversibile 1/4" ®	900/55	M100
5 inserti a profilo XZN® Ø 5-6-8-10-12 mm	867XZN	M86	21 chiavi a bussola esagonali 1/2" Ø 8-10-11-12-13-14-15-16-17-18-19-20-21-22-23-24-26-27-28-30-32 mm	920A	M100
5 inserti a profilo XZN® Ø 5-6-8-10-12 mm	867XZN/L	M86	1 raccordo con attacco quadro	920/15	M100
7 inserti per viti con impronta Torx® Ⓢ T20-T25-T30-T40-T45-T50-T55	867TX	M86	1 snodo 1/2"	920/25	M100
6 inserti per viti con impronta Torx® Ⓢ T25-T30-T40-T45-T50-T55	867TX/L	M86	1 prolunga angolare - 1/2" 125 mm	920AN/125	M100
7 inserti per viti con impronta Tamper Resistant Torx® Ⓢ T20-T25-T30-T40-T45-T50-T55	867RTX	M86	1 prolunga angolare - 1/2" 250 mm	920AN/250	M100
1 bussola portainseri per 867	867/1	M86	1 quadro maschio 1/2" con spina scorrevole	920/42	M100
1 bussola portainseri per 867	867/2	M86	1 cricchetto reversibile 1/2" ®	920/55	M100
1 bussola portainseri	895/1	M100	8 chiavi a bussola 1/2" per viti con teste a profilo Torx® Ⓢ 10-12-14-16-18-20-22-24 mm	920FTX	M100
1 bussola portainseri	895/3	M100	11 chiavi a bussola a mano lunghe bocca esagonale Ø 10-12-13-14-15-16-17-18-19-21-22	920AL	M100
1 bussola portainseri	895/6	M100	1 tronchesi a grande effetto taglienti diagonali 160 mm	1084BM	M136
13 chiavi a bussola esagonali 1/4" Ø 4-4,5-5-5,5-6-7-8-9-10-11-12-13-14 mm	900	M100	1 pinza universale 180 mm	1150BM	M136
9 chiavi a bussola a mano lunghe bocca esagonale Ø 5-6-7-8-9-10-11-12-13 mm	900L	M100	1 pinza a becchi mezzotondi diritti 160 mm	1166BM	M136
5 chiavi a bussola maschio esagonale 1/4" Ø 3-4-5-6-7 mm	900ME	M100	6 giravite lama piatta 2,5x50-3x75-4x100-5,5x125-6,5x150-8x200 mm	1201E	M213
4 chiavi a bussola a giravite per viti con intaglio Ø 0,8x4-1x5,5-1,2x6,5-1,2x8 mm	900LP	M100	1 giravite per viti a testa con intaglio 4x30 mm	1201EN	M213
4 chiavi a bussola a giravite per viti con impronta a croce Phillips® Ⓢ PH1-PH2-PH3-PH4	900PH	M100	4 giravite Phillips® Ⓢ PH0x60-PH1x80-PH2x100-PH3x150 mm	1202E	M213
7 chiavi a bussola a giravite maschio per viti con impronta Torx® Ⓢ T10-T15-T20-T25-T27-T30-T40	900TX	M100	1 giravite Phillips® Ⓢ PH1X30 mm	1202EN	M213
1 prolunga - 1/4" 50 mm	900/20	M100	12 chiavi maschio con impugnatura per viti con impronta Torx® Ⓢ T6-T7-T8-T9-T10-T15-T20-T25-T27-T30-T40-T45	1207E/TX	M213
1 prolunga - 1/4" 100 mm	900/20L	M100	1 giravite cercafase	1253	M213
			2 scalpelli piatti nervati 100-200 mm	35	M234
			1 martello tipo tedesco 300 g	1370	M234
			1 mazzuola con battenti in materiale plastico Ø 35 mm	1390	M234



5988U/7M 1.945,00 059881019

Assortimento consigliato in abbinamento con C23ST - C24S - C24SA - C24SA-XL - C24SL - C24SL/CAB - C28 - C37 - C39 - C39SM - C39MD - RSC55 - C59

5915VU/0

assortimento di 35 utensili

Universali



4,3 kg

N. pezzi/Descrizione

1	bulino 4 mm
1	scalpelli piatti nervati 125 mm
8	chiavi a forchetta 6x7-8x9-10x11-12x13-14x15-16x17-18x19-20x22 mm
7	chiavi maschio esagonale \odot 1,5-2-2,5-3-4-5-6 mm
1	chiave regolabile a rullino 150 mm
1	pinze regolabili cerniera chiusa 250 mm
1	tronchesi a taglienti diagonali, finitura industriale ∇ 160 mm
1	forbici per elettricisti lame dritte
1	pinze universali a grande effetto, finitura industriale \equiv 180 mm

Beta N.

32
35
55
96/BGS7
111
1048
1082G
1128BMX
1150G

N. pezzi/Descrizione

1	pinze a becchi mezzotondi lunghissimi, diritti zigrinati manici ricoperti con 2 strati di PVC antiscivolo, finitura industriale \bullet 160 mm
4	giravite lama piatta \bullet 3x75-4x100-5,5x100-6,5x150 mm
3	giravite Phillips® \bullet PH0x60-PH1x80-PH2x100 mm
1	martello tipo tedesco 300 g
1	flessometro 3 m
1	cutter con lama a settori 18 mm
1	coltello soccorso auto
1	torcia LED ad alta luminosità, fino a 500 Lumen

Beta N.

1166G
1201E
1202E
1370
1692/3
1771
1778SOS
1833S



5915VU/0 337,00 059151021

Assortimento consigliato in abbinamento con C4 - C5 - C6T

5915VU/1

assortimento di 45 utensili

Universali

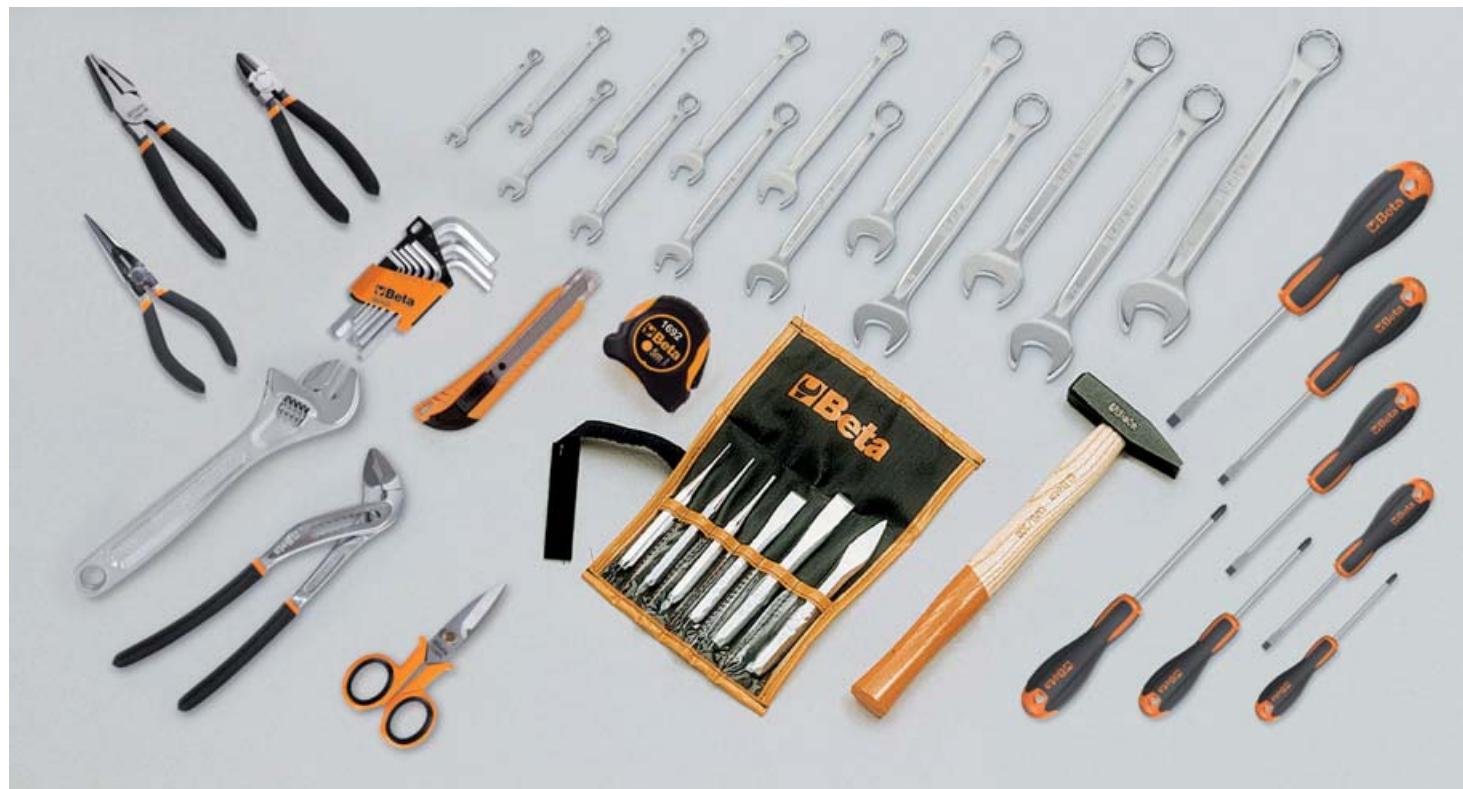

5 kg

N. pezzi/Descrizione

- 2 punzoni Ø 2-3 mm
- 1 bulino Ø 4 mm
- 2 scalpelli piatti 125-150 mm
- 1 ugnetti 150 mm
- 14 chiavi combinate 6÷14 - 17 - 19 - 21 - 22 - 24 mm
- 9 chiavi maschio esagonale piegate
Ø 1,5 - 2 - 2,5 - 3 - 4 - 5 - 6 - 8 - 10 mm
- 1 chiave regolabile a rullino 250 mm
- 1 pinze regolabili cerniera chiusa 250 mm
- 1 tronchesi a taglianti diagonali, finitura industriale \leq 160 mm

Beta N.

- 30
- 32
- 34
- 36
- 42NEW
- 96/SC9
- 111
- 1048
- 1082G

N. pezzi/Descrizione

- 1 forbici per elettricisti lame dritte
- 1 pinze universali a grande effetto, finitura industriale \approx 180 mm
- 1 pinze a becchi mezzotondi lunghissimi, diritti zigrinati manici ricoperti con 2 strati di PVC antiscivolo, finitura industriale \bullet 160 mm
- 4 giravite lama piatta \bullet 3x75 - 4x100 - 5,5x100 - 6,5x150 mm
- 3 giravite Phillips® \oplus PH0x60 - PH1x80 - PH2x100 mm
- 1 martello tipo tedesco 300 g
- 1 flessometro 5 m
- 1 cutter con lama a settori

Beta N.

- 1128BMX
- 1150G
- 1166G
- 1201E
- 1202E
- 1370
- 1692
- 1771



5915VU/1 413,00 059151024

Assortimento consigliato in abbinamento con C9 - C10 - C10S - C11 - CP15 - CP15L - C16 - CP17 - CP17L - C18

5915VU/2

assortimento di 49 utensili

Universali



4,6 kg

N. pezzi/Descrizione

- 8 chiavi a forchetta 6x7 - 8x9 - 10x11 - 12x13 - 14x15
16x17 - 18x19 - 20x22 mm
- 9 chiavi maschio esagonale piegate
Ø 1,5 - 2 - 2,5 - 3 - 4 - 5 - 6 - 8 - 10 mm
- 13 chiavi a bussola esagonali 1/4" Ø 4 - 4,5 - 5 - 5,5 - 6 - 7 - 8 - 9 - 10 -
11 - 12 - 13 - 14 mm
- 1 prolunga - 1/4" 150 mm
- 1 snodo 1/4"
- 1 quadro con impugnatura 1/4"
- 1 quadro scorrevole 1/4"

Beta N.
55/B8

96/SC9

900

900/21

900/25

900BG/30

900/42

N. pezzi/Descrizione

- 1 cricchetto reversibile 1/4" Ⓢ
- 1 pinze regolabili cerniera chiusa 250 mm
- 1 forbici per elettricisti lame dritte
- 1 pinze universali a grande effetto, finitura industriale = 180 mm
- 4 giravite lama piatta ● 3x75 - 4x100 - 5,5x150 - 6,5x150 mm
- 3 giravite Phillips® ● PH0x60 - PH1x80 - PH2x100 mm
- 1 martello tipo tedesco 300 g
- 1 flessometro 3 m
- 1 oliatore in plastica 30 cc
- 1 cutter con lama a settori 18 mm

Beta N.

900/55

1048

1128BMX

1150G

1201E

1202E

1370

1692

1755

1771



5915VU/2 354,00 059151027

Assortimento consigliato in abbinamento con C7 - CP15 - C20 - C20L

Universali



8,1 kg

N. pezzi/Descrizione

- 1 cacciaspina Ø 4 mm
- 1 bulino Ø 4 mm
- 1 scalpelli piatti 150 mm
- 14 chiavi combinate 6-7-8-10-11-12-13-14-15-16-17-19-22-24 mm
- 9 chiavi maschio esagonale piegate Ø 1,5÷10 mm
- 3 chiavi maschio esagonale con impugnatura Ø 4 - 5 - 6 mm
- 1 chiave regolabile a rullino 250 mm
- 13 chiavi a bussola esagonali 1/2"
 - 8÷17 - 19 - 22 - 24 mm
- 1 prolunga - 1/2" 255 mm
- 1 snodo 1/2"
- 1 quadro maschio 1/2" con spina scorrevole
- 1 cricchetto reversibile 1/2" Ⓞ
- 8 chiavi a tubo doppie serie leggera 6x7 - 8x9 - 10x11 - 12x13 - 14x15 - 16x17 - 18x19 - 20x22 mm
- 2 spine di manovra per chiavi a tubo 1 - 2

Beta N.

- 31
- 32
- 34
- 42NEW
- 96/SC9
- 96T
- 111
- 920A
- 920/22
- 920/25
- 920/42
- 920/55
- 935
- 940

N. pezzi/Descrizione

- 1 pinze regolabili cerniera chiusa 250 mm
- 1 pinza autobloccante 240 mm
- 1 tronchesi a grande effetto, a taglienti diagonali, finitura industriale 160 mm
- 1 forbici per elettricisti lame dritte
- 1 pinze universali a grande effetto, finitura industriale 180 mm
- 1 pinze a becchi mezzotondi lunghissimi, diritti zigrinati manici ricoperti con 2 strati di PVC antiscivolo, finitura industriale 160 mm
- 4 giravite lama piatta ● 3x75 - 4x100 - 5,5x150 - 6,5x150 mm
- 3 giravite Phillips® ⚡ PH0x60 - PH1x80 - PH2x100 mm
- 1 martello tipo tedesco 400 g
- 1 flessometro 5 m
- 1 seghetto
- 1 oliatore in plastica 150 cc
- 1 cutter con lama a settori

Beta N.

- 1048V
- 1052
- 1084G
- 1128BMX
- 1150G
- 1166G
- 1201E
- 1202E
- 1370
- 1692
- 1726
- 1755
- 1771



5915VU/3 763,00 059151028

Assortimento consigliato in abbinamento con C7 - C9 - C10 - C10S - C11 - CP15L - C16 - CP17 - CP17L - C19 - C19L - C20 - C20L

5915VU/4

assortimento di 80 utensili

Universali



11,2 kg

N. pezzi/Descrizione

- 1 cacciaspina Ø 4 mm
- 1 bulino Ø 4 mm
- 1 scalpelli piatti 150 mm
- 15 chiavi combinate 6-7-8-9-10-11-12-13-14-15-16-17-19-22-24 mm
- 9 chiavi maschio esagonale piegate Ø 1,5+10 mm
- 1 chiave regolabile a rullino 250 mm
- 13 chiavi a bussola esagonali 1/2"
 - 8+17 - 19 - 22 - 24 mm
- 1 prolunga - 1/2" 255 mm
- 1 snodo 1/2"
- 1 quadro maschio 1/2" con spina scorrevole
- 1 cricchetto reversibile 1/2" ®
- 17 chiavi a pipa doppie esagonali - poligonali 6+22 mm
- 1 pinze regolabili cerniera chiusa 250 mm

Beta N.

- 31
- 32
- 34
- 42NEW
- 96/SC9
- 111
- 920A
- 920/22
- 920/25
- 920/42
- 920/55
- 932/S17
- 1048

N. pezzi/Descrizione

- 1 pinza autobloccante 240 mm
- 1 tronchesi a grande effetto, a taglienti diagonali, finitura industriale 160 mm
- 1 forbici per elettricisti lame dritte
- 1 pinze universali a grande effetto, finitura industriale 180 mm
- 1 pinze a becchi mezzotondi lunghissimi, diritti zigrinati, impugnatura bimatereale, finitura industriale 160 mm
- 4 giravite lama piatta 3x75 - 4x100 - 5,5x150 - 6,5x150 mm
- 3 giravite Phillips® PH0x60 - PH1x80 - PH2x100 mm
- 1 martello tipo francese 32 mm
- 1 flessometro 5 m
- 1 seghetto
- 1 oliatore in plastica 150 cc
- 1 cutter con lama a settori

Beta N.

- 1052
- 1084GBM
- 1128BMX
- 1150GBM
- 1166GBM
- 1201E
- 1202E
- 1370F
- 1692
- 1726
- 1755
- 1771



5915VU/4 991,00 059151045

Assortimento consigliato in abbinamento con C20 - C20L

5915VU/5

assortimento di 111 utensili

Universali

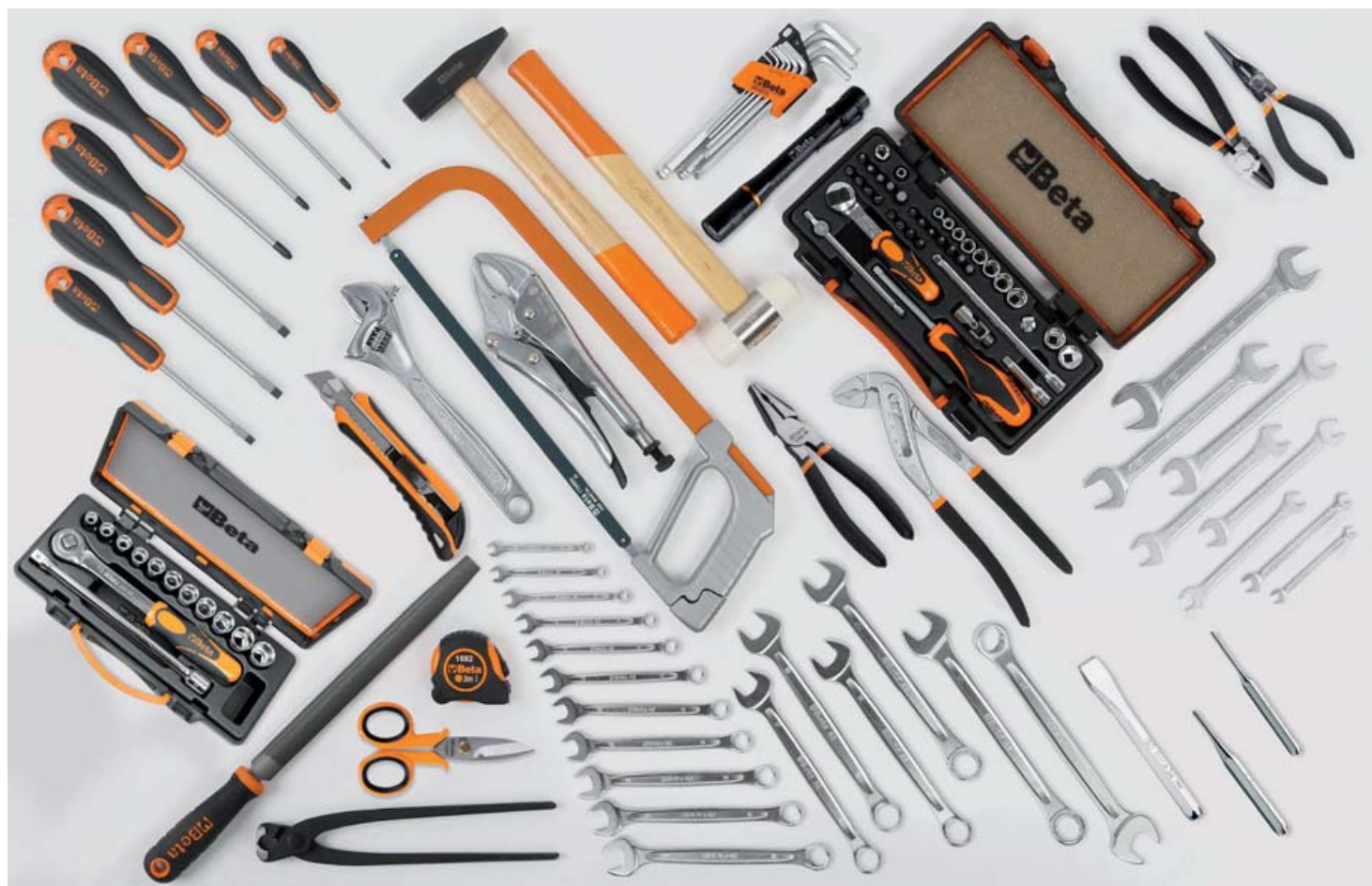

N. pezzi/Descrizione

- 1 cacciaspina Ø 4 mm
- 1 bulino Ø 4 mm
- 1 scalpelli piatti 150 mm
- 17 chiavi combinate 6-7-8-9-10-11-12-13-14-15-16-17-18-19-20-21-22 mm
- 8 chiavi a forchetta 6x7-8x9-10x11-12x13-14x15-16x17-18x19-20x22 mm
- 9 chiavi maschio esagonale piegate con estremità sferica ○
- 1 chiave regolabile a rullino 250 mm
- 39 Serie di bussole e accessori, in cassetta
- 13 Serie di bussole e accessori, in cassetta
- 1 pinze regolabili cerniera chiusa 250 mm
- 1 pinza autobloccante 240 mm
- 1 tronchesi a taglienti diagonali, finitura industriale 160 mm

Beta N.

- 31
- 32
- 34
- 42NEW
- 55/S8
- 96BPC/SC9
- 111
- 900/C11
- 920A/C11
- 1048
- 1052
- 1082G

N. pezzi/Descrizione

- 1 tenaglie per cementisti 220 mm
- 1 forbici per elettricisti lame diritte
- 1 pinze universali a grande effetto, finitura industriale 180 mm
- 1 pinze a becchi mezzotondi lunghissimi, diritti zigrinati manici ricoperti con 2 strati di PVC antiscivolo, finitura industriale 160 mm
- 3 giravite Phillips® PH0x60 - PH1x80 - PH2x100 mm
- 1 martello tipo tedesco 300 g
- 1 mazzuola con battenti in materiale plastico Ø 35 mm
- 1 flessometro 3 m
- 1 lime a taglio mezzodolce
- 1 seghetto 440 mm
- 1 cutter con lama a settori 18 mm
- 1 torcia LED per ispezioni
- 4 giravite lama piatta 3x75 - 4x100 - 5,5x100 - 6,5x150 mm

Beta N.

- 1098
- 1128BMX
- 1150G
- 1166G
- 1202E
- 1370
- 1390
- 1692/3
- 1719BMA8/M
- 1726
- 1771BM
- 1833XS/2
- 1201E



5915VU/5

968,00 059151046

Assortimento consigliato in abbinamento con C12 - C41H - C41S - C42H - C42S

Universali



9,3 kg

N. pezzi/Descrizione

- 1 cacciaspina Ø 4 mm
- 1 bulino Ø 4 mm
- 1 scalpelli piatti 150 mm
- 13 chiavi combinate 1/4 - 5/16 - 3/8 - 7/16 - 1/2 - 9/16 - 5/8 - 11/16 - 3/4 - 13/16 - 7/8 - 15/16 - 1"
- 8 chiavi poligonali curve 1/4"+1"
- 9 chiavi maschio esagonale piegate brunate ○ 3/64"+3/8"
- 1 chiave regolabile a rullino 250 mm
- 11 chiavi a bussola poligonali □ 1/2" ○ 3/8 - 7/16 - 1/2 - 9/16 - 5/8 - 11/16 - 3/4 - 13/16 - 7/8 - 15/16 - 1"
- 1 prolunga - 1/2" 125 mm
- 1 prolunga - 1/2" 255 mm
- 1 snodo 1/2"
- 1 quadro maschio 1/2" con spina scorrevole
- 1 cricchetto reversibile 1/2" ⊗

Beta N.

- 31
- 32
- 34
- 42AS
- 90AS/8
- 96AS/SC9
- 111
- 920AS
- 920/21
- 920/22
- 920/25
- 920/42
- 920/55

N. pezzi/Descrizione

- 1 pinze regolabili cerniera chiusa 250 mm
- 1 pinza autobloccante 240 mm
- 1 tronchesi a grande effetto, a taglianti diagonali, finitura industriale ϵ 160 mm
- 1 forbici per elettricisti lame diritte
- 1 pinze universali a grande effetto, finitura industriale \equiv 180 mm
- 1 pinze a becchi mezzotondi lunghissimi, diritti zigrinati, impugnatura bimatereale, finitura industriale \bullet 160 mm
- 4 giravite lama piatta \bullet 3x75 - 4x100 - 5,5x150 - 6,5x150 mm
- 3 giravite Phillips \oplus PH0x60 - PH1x80 - PH2x100 mm
- 1 martello tipo tedesco 300 g
- 1 flessometro 5 m
- 1 seghetto
- 1 oliatore in plastica 150 cc
- 1 cutter con lama a settori

Beta N.

- 1048
- 1052
- 1084GBM
- 1128BMX
- 1150GBM
- 1166GBM
- 1201E
- 1202E
- 1370
- 1692
- 1726
- 1755
- 1771



5915VU/AS 836,00 059151032

Assortimento consigliato in abbinamento con C10 - C20 - C20L

592VU/M

assortimento di 108 utensili in vassoio morbido in EVA

Universali



MC10



MC20

N. pezzi/Descrizione	Beta N.	TR	N. pezzi/Descrizione	Beta N.	TR
16 chiavi combinate 6-7-8-9-10-11-12-13 14-15-16-17-18-19-21-22 mm	42NEW	MC10	1 ugnetti 4 mm	36	MC20
9 chiavi maschio esagonale piegate Ø 1,5-2-2,5-3-4-5-6-8-10 mm	96/SC9	MC10	13 chiavi a bussola esagonali 1/4" Ø 4-4,5-5-5,5-6-7-8-9-10-11- 12-13-14 mm	900	MC20
1 tronchesi a grande effetto taglienti diagonali 160 mm	1084BM	MC10	1 prolunga - 1/4" 150 mm	900/21	MC20
1 pinze universali a grande effetto, finitura industriale 180 mm	1150G	MC10	1 snodo 1/4"	900/25	MC20
1 pinze a becchi mezzotondi lunghissimi, diritti zigrinati manici ricoperti con 2 strati di PVC antiscivolo, finitura industriale 160 mm	1166G	MC10	1 quadro maschio 1/4"	900BG/30C	MC20
3 giravite lama piatta 3,5x100-5,5x150-6,5x150 mm	1201E	MC10	1 quadro scorrevole 1/4"	900/42	MC20
3 giravite Phillips® PH0x3x60-PH1x4,5x80-PH2x6x100 mm	1202E	MC10	1 cricchetto reversibile 1/4" ®	900/55	MC20
31 inserti colorati con portainseriti magnetico in astuccio tascabile ● ○ ⊕ ⊕ ⊕ ⊕	860MIX/A31	MC20	16 chiavi a bussola esagonali 1/2" Ø 10-11-12-13-14-15-16-17- 18-19-21-22-24-27-30-32 mm	920A	MC20
1 pinze regolabili cerniera chiusa 250 mm	1048	MC20	1 snodo 1/2"	920/25	MC20
1 martello tipo tedesco 300 mm	1370	MC20	1 prolunga angolare - 1/2" 125 mm	920AN/125	MC20
1 bulino 4 mm	32	MC20	1 quadro scorrevole 1/4"	900/42	MC20
			1 cricchetto reversibile 1/4" ®	900/55	MC20
			1 bussola portainseriti	895/1	MC20



592VU/M

833,00 059271021

Assortimento consigliato in abbinamento con C22S - C23S - C23SC - C27S

Universali

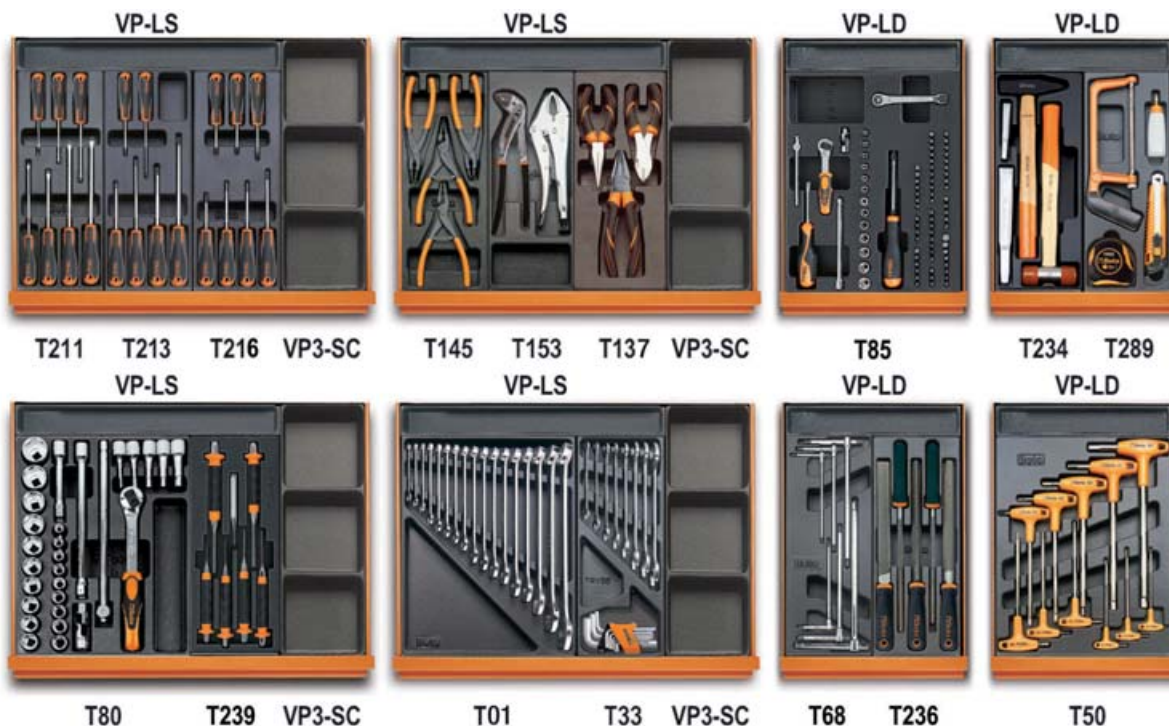

23,5 kg

N. pezzi/Descrizione

Beta N. TR N. pezzi/Descrizione

Beta N. TR

- 7 giravite lama piatta ● 2,5x50 - 3x75 - 3,5x100 - 4x125 - 5,5x100 - 5,5x150 - 6,5x150 mm
- 6 giravite Phillips® ● PH0x60-PH1x80-PH1x120-PH2x100-PH2x150-PH3x150 mm
- 7 chiavi maschio con impugnatura per viti con impronta Torx® ● T6-T7-T8-T9-T10-T15-T20
- 1 pinza becchi dritti per anelli elastici, per fori ○ 180 mm
- 1 pinza becchi piegati per anelli elastici, per fori ○ 170 mm
- 1 pinza becchi dritti per anelli elastici, per alberi ● 175 mm
- 1 pinza becchi piegati per anelli elastici, per alberi ● 175 mm
- 1 pinze regolabili cerniera chiusa 240 mm
- 1 pinza autobloccante 240 mm
- 1 tronchese a grande effetto taglienti diagonali ✂ 160 mm
- 1 pinza universale = 180 mm
- 1 pinza a becchi mezzotondi dritti ● 160 mm
- 1 chiave portainseri a cricchetto reversibile 1/4x5/16
- 13 chiavi a bussola esagonali 1/4" ○ 4-4,5-5-5,5-6-7-8-9-10-11-12-13-14 mm
- 1 cricchetto reversibile 1/4" ⊕ 125 mm
- 1 quadro scorrevole 1/4" 115 mm
- 1 quadro con impugnatura 1/4" 176 mm
- 1 snodo 1/4" 41 mm
- 1 prolunga - 1/4" 150 mm
- 1 portainseri a sgancio rapido con impugnatura 230 mm
- 5 inserti per avvitatori per viti con impronta Spanner ● 4-6-8-10-12 mm
- 8 inserti per avvitatori per viti con impronta Torq-Set® ● 0-1-2-3-4-5-6-8 mm
- 6 inserti per avvitatori per viti con impronta Tri-Wing® ● 1-2-3-4-5-6 mm
- 8 inserti per avvitatori per viti con impronta Tamper Resistant Torx® ● T9-T10-T15-T20-T25-T27-T30-T40
- 11 inserti per avvitatori per viti con impronta Torx® ● T6-T7-T8-T9-T10-T15-T20-T25-T27-T30-T40
- 3 inserti per avvitatori per viti con impronta a croce Pozidriv® - Supadriv® ● PZ1 - PZ2 - PZ3

- 1201E T211
- 1202E T213
- 1207E/TX T216
- 1032 T145
- 1034 T145
- 1036 T145
- 1038 T145
- 1048 T153
- 1052 T153
- 1084BM T137
- 1150BM T137
- 1166BM T137
- 194 T85
- 900 T85
- 900/55 T85
- 900/42 T85
- 900BG/30 T85
- 900/25 T85
- 900/21 T85
- 851SR T85
- 861SP T85
- 861TQS T85
- 861TRW T85
- 861RTX T85
- 861TX T85
- 861PZ T85

- 4 inserti per avvitatori per viti con impronta a croce Phillips® ● PH0 - PH1 - PH2 - PH3
- 8 inserti maschio esagonale per avvitatori ○ 2 - 2,5 - 3 - 4 - 5 - 6 - 8 - 10 mm
- 7 inserti per avvitatori per viti a testa con intaglio ● 0,5x3 - 0,6x4,5 - 0,8x5,5 - 1x5,5 - 1,2x6,5 - 1,2x8 - 1,6x8 mm
- 2 scalpelli piatti nervati 100 - 200 mm
- 1 martello tipo tedesco 300 g
- 1 mazzuola con battenti in materiale plastico Ø 35 mm
- 1 flessometro 5 m
- 1 miniseghetto
- 1 oliatore in plastica
- 1 cutter con lama a settori
- 19 chiavi a bussola esagonali 1/2" ○ 10 - 11 - 12+19 - 20 - 21 - 22 - 23 - 24 - 26 - 27 - 30 - 32 mm
- 5 chiavi a bussola maschio esagonale 1/2" ○ 5 - 6 - 8 - 10 - 12 mm
- 1 prolunga - 1/2" 125 mm
- 1 prolunga - 1/2" 255 mm
- 1 snodo 1/2"
- 1 quadro maschio 1/2" con spina scorrevole
- 1 cricchetto reversibile 1/2" ⊕
- 1 bulino Ø 4 mm
- 6 cacciaspina con impugnatura 2-3-4-5-6-8 mm
- 17 chiavi combinate 6-7-8-10-11-12-13-14-16-17-18-19-21-22-24-27-30 mm
- 8 chiavi a forchetta 6x7 - 8x9 - 10x11 - 12x13 - 14x15 - 16x17 - 18x19 - 20x22 mm
- 9 chiavi maschio esagonale piegate ○
- 6 chiavi a T maschio esagonale ○ 2,5 - 3 - 4 - 5 - 6 - 8 mm
- 5 lime a taglio mezzodolce 200 mm
- 11 chiavi maschio esagonale con impugnatura ○ 2 - 2,5 - 3 - 3,5 - 4 - 4,5 - 5 - 6 mm
- 4 termoformati vuoti
- 4 termoformati vuoti
- 4 termoformati vuoti

- 861PH T85
- 861PE T85
- 861LP T85
- 35 T234
- 1370 T234
- 1390 T234
- 1692 T289
- 1725CR T289
- 1755 T289
- 1771 T289
- 920A T80
- 920ME T80
- 920/21 T80
- 920/22 T80
- 920/25 T80
- 920/42 T80
- 920/55 T80
- 32 T239
- 31BM T239
- 42NEW T01
- 55 T33
- 96/SC9 T33
- 951 T68
- 1719BMA8/S5 T236
- 96T T50
- VP-3SC VP-3SC
- VP-LS VP-LS
- VP-LD VP-LD



5938U/2T 2.010,00 059381062

Assortimento consigliato in abbinamento con C38

5957U-P

assortimento di 133 utensili - accessori di fissaggio inclusi

Universali



N. pezzi/Descrizione

6	cacciaspina 2 ÷ 8 mm	
6	2 punzoni, 1 bulino, 3 scalpelli con supporto	
17	serie di chiavi combinate 6÷22 - 24 - 27 - 30 - 32 mm	
12	chiavi a forchetta 6x7 ÷ 30x32 mm	
8	chiavi maschio esagonale con impugnatura 2 ÷ 10 mm	
8	chiavi maschio piegate	
	per viti con impronta Torx® ⌘ T9 ÷ T40	
1	chiave regolabile a rullino 250 mm	
13	chiavi a bussola esagonali 1/2" con guida ⌀ 10 ÷ 22 mm	
8	chiavi a bussola esagonali 1/2" con guida ⌀ 23 ÷ 32 mm	
7	chiavi a bussola a giravite	
	per viti con impronta a croce Phillips® ⬤	
	⊕ 1,2x65 - 1,2x8 - 1,6x9 - 2x12mm - PH1-PH2-PH3	
1	pinze becchi dritti per anelli elastici, per fori ⌀ 180 mm	1032
1	pinze becchi piegati per anelli elastici, per fori ⌀ 170 mm	1034
1	pinze becchi dritti per anelli elastici, per alberi ⌀ 175 mm	1036
1	pinze becchi piegati per anelli elastici, per alberi ⌀ 175 mm	1038
1	pinze regolabili cerniera chiusa 250 mm	1048
1	pinza autobloccante 240 mm	1052
1	cesoia a lame larghe diritte 250 mm	1112
1	forbici per elettricisti lame diritte	1128BMX
8	giravite 2,5x50 - 3x75 - 4x100 - 5,5x125	1263/D8
	6,5x150 - PH0 - PH1 - PH2	
2	martello tipo tedesco 300 - 600 g	1370
1	mazzuola con battenti in materiale plastico 35	1390

Beta N.

N. pezzi/Descrizione

1	flessometro 5 m	1692/5
1	flessibile magnetico	1712E/2
1	raschietto a due taglienti 200 mm	1717A
1	raschietto a tre taglienti 200 mm	1717B
5	lime a taglio mezzodolce 200 mm	1719BMA8/S5
1	oliatore in metallo a pressione 200 cc	1751
1	cutter con lama a settori	1771BM
1	prolunga - 1/2" 125 mm	920/21
1	prolunga - 1/2" 250 mm	920/22
1	snodo 1/2"	920/25
1	quadro maschio 1/2" con spina scorrevole	920/42
1	cricchetto reversibile 1/2" ⌘	920/55
1	leva con estremità a punta e piatta curva	963
1	tronchesi a taglienti diagonali ⚡ 160 mm	1082BM
1	tronchesi a grande effetto taglienti diagonali ⚡ 160 mm	1084BM
1	tronchesi doppia leva taglio frontale ⚡ 180 mm	1092V
1	pinza universale = 180 mm	1150BM
1	pinza a becchi mezzotondi dritti ⬤ 160 mm	1166BM
1	pinza a becchi mezzotondi piegati ⬤ 160 mm	1168BM
2	giravite lama piatta ⬤ 8x200 - 10x200 mm	1260
1	giravite per viti con impronta a croce Phillips® ⊕ PH3 8x150mm	1262
1	calibro a corsoio	1650
1	seghetto 420 mm	1725

Beta N.

1692/5
1712E/2
1717A
1717B
1719BMA8/S5
1751
1771BM
920/21
920/22
920/25
920/42
920/55
963
1082BM
1084BM
1092V
1150BM
1166BM
1168BM
1260
1262
1650
1725



5957U-P 2.075,00 059571004

Assortimento consigliato in abbinamento con C57SA - C57SB - C57SP - C55PS - C55

5958U

assortimento di 85 utensili - accessori di fissaggio inclusi

Universali**11,3 kg****N. pezzi/Descrizione**

- 17 chiavi combinate 6÷22 mm
- 12 chiavi maschio esagonale piegate \varnothing 2÷10 mm
- 13 chiavi a bussola esagonali 1/2" con guida \varnothing 10÷22 mm
- 8 chiavi a bussola esagonali 1/2" con guida \varnothing 23÷32 mm
- 1 prolunga - 1/2" 125 mm
- 1 prolunga - 1/2" 255 mm
- 1 snodo 1/2"
- 1 quadro maschio 1/2" con spina scorrevole
- 1 cricchetto reversibile 1/2" \otimes
- 1 pinze becchi dritti per anelli elastici, per fori \varnothing 180 mm
- 1 pinze becchi dritti per anelli elastici, per alberi \bullet 175 mm
- 1 pinze regolabili cerniera chiusa 250 mm
- 1 pinza autobloccante 240 mm
- 1 tronchesi a grande effetto taglienti diagonali ∇ 160 mm
- 1 forbici per elettricisti lame dritte
- 1 pinza universale \equiv 180 mm

Beta N.

- 42NEW
- 96N/SC12
- 920A/SB13
- 920A/SB8
- 920/21
- 920/22
- 920/25
- 920/42
- 920/55
- 1032
- 1036
- 1048
- 1052
- 1084BM
- 1128BMX
- 1150BM

N. pezzi/Descrizione

- 1 pinza a becchi mezzotondi dritti \bullet 160 mm
- 7 giravite lama piatta \bullet 3x75 - 3,5x100 - 4x125
5,5x150 - 6,5x150 - 8x200 - 10x200 mm
- 4 giravite Phillips® \oplus PH0x60 - PH1x80
PH2x100 - PH3x150 mm
- 1 martello tipo tedesco 300 g
- 1 mazzuola con battenti in materiale plastico \varnothing 35 mm
- 1 flessometro 5 m
- 5 serie di 5 lime 200 mm
- 1 seghetto
- 1 oliatore in plastica a pressione 150 cc
- 1 cutter con lama a settori

Beta N.

- 1166BM
- 1260
- 1262/S4
- 1370
- 1390
- 1692
- 1719BMA...S5
- 1725
- 1754
- 1771



5958U 1.054,00 059581008

Assortimento consigliato in abbinamento con C58P - C45 - C55

Riparazione biciclette



N. pezzi/Descrizione

- 5 chiavi combinate 8-9-10-13-14 mm
- 9 serie di chiavi maschio esagonale piegate con estremità sferica ○ 1,5-2-2,5-3-4-5-6-8-10 mm
- 8 chiavi maschio esagonale con impugnatura 2-2,5-3-4-5-6-8-10 mm
- 8 chiavi maschio con impugnatura per viti con impronta Torx® ⚙ T8-T10-T15-T20-T25-T27-T30-T40
- 1 chiavi regolabili a rullino con scala graduata 200 mm
- 1 tagliatubi per rame e leghe leggere
- 1 chiavi dinamometriche a scatto con cricchetto reversibile 2+10 Nm
- 13 chiavi a bussola a mano bocca esagonale ○ 4-4,5-5-5,5-6-7-8-9-10-11-12-13-14 mm
- 1 prolunga - 1/4"
- 1 snodo 1/4"
- 1 cricchetto reversibile 1/4" ⚙
- 1 tronchesi a taglianti diagonali 160 mm
- 1 forbici per elettricisti lame dritte 145 mm
- 1 pinze universali a grande effetto, finitura industriale 180 mm
- 1 pinze a becchi mezzotondi lunghissimi, diritti zigrinati manici ricoperti con 2 strati di PVC antiscivolo, finitura industriale 180 mm
- 7 serie giravite 3x75-4x125-5,5x150-6,5x150-PH0x60-PH1x80-PH2x100 mm

Beta N.

- 42NEW
- 96BP/SC9
- 96T/S8
- 97TTX/S8
- 111G
- 334
- 605E
- 900/SB13
- 900/21
- 900/25
- 900/55
- 1082
- 1128BM
- 1150G
- 1166G
- 1203E/D

N. pezzi/Descrizione

- 1 martello tipo tedesco 300 g
- 1 mazzuola con battenti in materiale plastico Ø 35 mm
- 1 calibro a corsoio 150 mm
- 1 flessometro 3 m
- 1 lima 200 mm
- 1 lima 200 mm
- 1 seghetto 300 mm
- 1 cutter con lama a settori
- 1 indicatore usura catena 120 mm
- 1 pinza per falsamaglia 170 mm
- 7 chiavi coniche semplici 13-14-15-16-17-18-19 mm
- 1 chiave per pedali 15 mm
- 1 tiraraggi nero 3,2mm □
- 1 tiraraggi verde 3,3 mm □
- 1 tiraraggi rosso 3,5 mm □ 3
- 1 tiraraggi professionale □ 3,2 - 4,0 mm
- 1 chiave frusta smonta-pignoni 289 mm
- 1 levagomme 200 mm
- 3 kit di 3 levagomme, in plastica 113 mm
- 1 leva per arretrare pastiglie freni a disco 222 mm
- 1 chiave per raddrizzare dischi freno 234 mm

Beta N.

- 1370
- 1390
- 1650
- 1692/3
- 1719BMA...P
- 1719BMA...M
- 1719BMA...R
- 1725
- 1771
- 3935
- 3937
- 3952/S7
- 3953
- 3961 3,2
- 3961 3,3
- 3961 3,5
- 3961U
- 3967
- 3969
- 3969K3
- 3991
- 3992



5980U/BIKE 1.250,00 059801040

Assortimento consigliato in abbinamento con C16 - CP17 - CP17L - C20L

Autoriparazione



M125



M25



M105



M166



M231



M62



M77

N. pezzi/Descrizione

Beta N. TR

N. pezzi/Descrizione

Beta N. TR

13	chiavi a bussola a mano lunghe bocca esagonale ◯ 8-9-10-11-12-13-14-15-16-17-19-21-22 mm	910AL	M125
16	chiavi a bussola a mano lunghe bocca esagonale ◯ 10-12-13-14-15-16-17-18-19-21-22-23-24-27-30-32 mm	920AL	M125
7	chiavi a bussola 1/2" per viti con teste a profilo Torx® ◯ E12-E14-E16-E18-E20-E22-E24	920FTX	M125
10	chiavi a bussola maschio esagonale 1/2" ◯ 5-6-6L-7-8-8L-10-10L-12-12L mm	920PE	M125
13	chiavi a bussola maschio per viti con impronta Torx® 1/2" ◯ T20-T25-T27-T30-T30L-T40-T40L-T45-T50-T50L-T55-T60-T60L	920TX	M125
8	chiavi a bussola maschio a profilo XZN® ◯ 5-6-6-6L-8-8L-10-10L-12L mm	920XZN	M125
18	chiavi combinate 6-7-8-9-10-11-12-13-14-15-16-17-18-19-21-22-24-27 mm	42NEW	M25
7	chiavi poligonali curve 6x7-8x9-10x11-12x13-14x15-16x17-18x19 mm	90	M25
1	adattatore a sgancio rapido 1/4" per chiavi a cricchetto 10 mm	123Q1/4	M25
1	adattatore a sgancio rapido 3/8" per chiavi a cricchetto 13 mm	123Q3/8	M25
1	adattatore a sgancio rapido 1/2" per chiavi a cricchetto 19 mm	123Q1/2	M25
12	chiavi combinate a cricchetto reversibile 8-9-10-11-12-13-14-15-16-17-18-19 mm	142	M25
9	chiavi maschio esagonale piegate con estremità sferica ◯ 1,5-2-2,5-3-4-5-6-8-10 mm	96BPC/SC9	M105
1	bussola portainseri ◯ 1/4-□ 1/4	895/1	M105
1	bussola portainseri ◯ 1/4-□ 3/8	895/3	M105
1	bussola portainseri ◯ 5/16-□ 1/2	895/6	M105
13	chiavi a bussola esagonali 1/4" ◯ 4-4,5-5-5,5-6-7-8-9-10-11-12-13-14 mm	900	M105
9	chiavi a bussola a mano lunghe bocca esagonale ◯ 5-6-7-8-9-10-11-12-13 mm	900L	M105
4	chiavi a bussola a giravite per viti con intaglio ◯ 0,8x4-1x5-5,1,2x6,51,2x8 mm	900LP	M105
5	chiavi a bussola maschio esagonale 1/4" ◯ 3-4-5-6-7 mm	900ME	M105
4	chiavi a bussola a giravite per viti con impronta a croce Phillips® ◯ PH1-PH2-PH3-PH4	900PH	M105
7	chiavi a bussola a giravite maschio per viti con impronta Torx® ◯ T10-T15-T20-T25-T27-T30-T40	900TX	M105
1	raccordo con attacco quadro □ 1/4-■ 3/8	900/16	M105
3	prolunga - 1/4" 50-100-150 mm	900/...	M105
1	snodo 1/4"	900/25	M105
1	quadro scorrevole 1/4"	900/42	M105
1	cricchetto reversibile 1/4" ⊗	900/55	M105
1	quadro con impugnatura 1/4"	900BG/30	M105
17	chiavi a bussola esagonali 3/8" ◯ 6-7-8-9-10-11-12-13-14-15-16-17-18-19-20-21-22 mm	910A	M105
1	raccordo con attacco quadro □ 3/8-■ 1/4	910/15	M105
1	raccordo quadro maschio 1/2" e femmina 3/8" □ 3/8-■ 1/2	910/16	M105
1	prolunga - 3/8" 125 mm	910/21	M105
1	prolunga - 3/8" 250 mm	910/22	M105
1	snodo 3/8"	910/25	M105
1	quadro maschio 3/8" con spina scorrevole	910/42	M105
1	cricchetto reversibile 3/8" ⊗	910/55	M105
21	chiavi a bussola esagonali 1/2" ◯ 8-10-11-12-13-4-15-16-17-18-19-20-21-22-23-24-26-27-28-30-32 mm	920A	M105
2	prolunga angolare - 1/2" 125-250 mm	920AN	M105
1	raccordo con attacco quadro □ 1/2-■ 3/8	920/15	M105
1	snodo 1/2"	920/25	M105
1	quadro maschio 1/2" con spina scorrevole	920/42	M105
1	cricchetto reversibile 1/2" ⊗	920/55	M105
3	chiavi a bussola per candele 3/8" ◯ 16-17,8-20,8 mm	956E	M105
31	inserti colorati con portainseri magnetico in astuccio tascabile ◯ ◯ ◯ ◯ ◯	860MIX/A31	M166

1	pinze regolabili cerniera chiusa 250 mm	1048	M166
1	tronchesi a taglienti diagonali ◯ 160 mm	1082BM	M166
1	pinza universale = 180 mm	1150BM	M166
1	pinza becchi piatti diritti = 160 mm	1162BM	M166
5	giravite lama piatta ◯ 3x75-4x100-5,5x100-6,5x150-8x150 mm	1290	M166
1	giravite nano lama piatta ◯ 6,5x30 mm	1290N	M166
3	giravite Phillips® ◯ PH1-PH2-PH3	1292	M166
1	giravite nano Phillips® ◯ PH2	1292N	M166
4	chiavi maschio con impugnatura per viti con impronta Torx® ◯ T20-T25-T27-T30	1297TX	M166
6	cacciaspina 2-3-4-5-6-8 mm	31	M231
1	bulino 4 mm	32	M231
3	scalpelli piatti 125-150-75 mm	34	M231
1	ugnetti 125 mm	36	M231
2	martello tipo tedesco 500-1000 g	1370	M231
1	magnete telescopico con testa flessibile	1712TF	M231
1	mazzuola con battenti in materiale plastico Ø 35 mm	1390	M231
1	flessometro 5 m	1692	M125
1	pinze becchi diritti per anelli elastici, per fori ◯ 180 mm	1032	M62
1	pinze becchi piegati per anelli elastici, per fori ◯ 170 mm	1034	M62
1	pinze becchi diritti per anelli elastici, per alberi ◯ 175 mm	1036	M62
1	pinze becchi piegati per anelli elastici, per alberi ◯ 175 mm	1038	M62
1	pinza a becchi mezzotondi lunghi lisci ◯ 140 mm	1177BM	M62
1	tronchese a taglienti diagonali normali ◯ 125 mm	1188BM	M62
4	microgiravite per viti senza testa con intaglio ◯ 2,0-2,5-3,0-3,5 mm	1257LP	M62
2	microgiravite per viti con impronta a croce Phillips® ◯ 0-00	1257PH	M62
9	chiavi maschio con impugnatura per viti con impronta Torx® ◯ T10-T15-T20-T25-T27-T30-T40-T45-T50	97TTX	M62
1	pinza autobloccante 240 mm	1052	M77
1	pinza autobloccante becchi lunghi 180 mm	1058	M77
1	pinze in plastica per occlusione tubi	1481PL/A	M77
1	pinza in plastica per occlusione tubi e manicotti	1481PL/B	M77
1	pinza in plastica per occlusione tubi e manicotti	1481PL/C	M77
1	calibro a corsoio	1650	M77
1	spessimetro	1708/20	M77
1	raschietto per guarnizioni	1716P	M77
7	chiavi a bussola poligonale snodate doppie 6x7-8x9-10x11-12x13-14x15-16x17-18x19 mm	80	M77
1	quadro maschio 1/2" snodato con impugnatura	920/36A	M77
1	leva piastra curva con impugnatura 450 mm	965	M77
1	specchietto telescopico 670 mm	1715	M231
1	lime a taglio mezzodolce 200 mm	1719BMA8/M	M231
1	lime a taglio mezzodolce 200 mm	1719BMA8/P	M231
1	lime a taglio mezzodolce 200 mm	1719BMA8/Q	M231
1	lime a taglio mezzodolce 200 mm	1719BMA8/R	M231
1	lime a taglio mezzodolce 200 mm	1719BMA8/T	M231
1	spazzola fili d'acciaio	1737NX	M231

€ 4.370,00 059881087

5988H/7M

Assortimento consigliato in abbinamento con C24S da 8 cassetti - C24SA da 8 cassetti - C24SA-XL da 8 cassetti - C37 da 8 cassetti - C39 da 8 cassetti - C28 - C59B

Autoriparazione



M105



M125



M25



M166

N. pezzi/Descrizione

- 13 chiavi a bussola esagonali 1/4" ○ 4-4,5-5-5,5-6-7-8-9-10-11-12-13-14 mm
- 9 chiavi a bussola a mano lunghe bocca esagonale ○ 5-6-7-8-9-10-11-12-13 mm
- 9 chiavi maschio esagonale piegate con estremità sferica ○ 1,5-2-2,5-3-4-5-6-8-10 mm
- 1 bussola portainseriti
- 1 bussola portainseriti
- 1 bussola portainseriti
- 5 chiavi a bussola maschio esagonale 1/4" ○ 3-4-5-6-7 mm
- 4 chiavi a bussola a giravite per viti con intaglio ● 0,8x4-1x5,5-1,2x6,5-2x8 mm
- 4 chiavi a bussola a giravite per viti con impronta a croce Phillips® ● PH1-PH2-PH3-PH4
- 7 chiavi a bussola a giravite maschio per viti con impronta Torx® ○ T10-T15-T20-T25-T27-T30-T40
- 1 raccordo con attacco quadro □ 1/4 - ■ 3/8
- 3 prolunga - 1/4" 50-100-150 mm
- 1 snodo 1/4"
- 1 quadro con impugnatura 1/4"
- 1 quadro scorrevole 1/4"
- 1 cricchetto reversibile 1/4" ⊗
- 17 chiavi a bussola esagonali 3/8" ○ 6-7-8-9-10-11-12-13-14-15-16-17-18-19-20-21-22 mm
- 1 raccordo con attacco quadro □ 3/8 - ■ 1/4
- 1 raccordo quadro maschio 1/2" e femmina 3/8" □ 3/8 - ■ 1/2
- 1 prolunga - 3/8" 125 mm
- 1 prolunga - 3/8" 250 mm
- 1 snodo 3/8"
- 1 quadro maschio 3/8" con spina scorrevole
- 1 cricchetto reversibile 3/8" ⊗
- 17 chiavi a bussola esagonali 1/2" ○ 8-10-11-12-13-14-15-16-17-18-19-20-21-22-23-24-26-27-28-30-32 mm
- 1 raccordo con attacco quadro □ 1/2 - ■ 3/8
- 1 snodo 3/8"
- 2 prolunga angolare - 1/2" 125 - 250 mm
- 1 quadro maschio 1/2" con spina scorrevole
- 1 cricchetto reversibile 1/2" ⊗

Beta N.

TR

- 900
- 900L
- 96BPC/SC9
- 895/1
- 895/3
- 895/6
- 900ME
- 900LP
- 900PH
- 900TX
- 900/16
- 900/...
- 900/25
- 900BG/30
- 900/42
- 900/55
- 910A
- 910/15
- 910/16
- 910/21
- 910/22
- 910/25
- 910/42
- 910/55
- 920A
- 920/15
- 910/25
- 920AN
- 920/42
- 920/55

N. pezzi/Descrizione

- 3 chiavi a bussola per candele 3/8" ○ 16-17,8-20,8 mm
- 13 chiavi a bussola a mano lunghe bocca esagonale ○ 8-9-10-11-12-13-14-15-16-17-19-21-22 mm
- 10 chiavi a bussola maschio esagonale 1/2" ○ 5-6-6L-7-8-8L-10-10L-12-12L mm
- 7 chiavi a bussola 1/2" per viti con teste a profilo Torx® ● E12-E14-E16-E18-E20-E22-E24
- 13 chiavi a bussola maschio per viti con impronta Torx® 1/2" ○ T20-T25-T27-T30-T30L-T40-T40L-T45-T50-T50L-T55-T60-T60L
- 8 chiavi a bussola maschio a profilo XZN® ○ 5-6-6L-8-8L-10-10L-12L mm
- 16 chiavi a bussola a mano lunghe bocca esagonale ○ 10-12-13-14-15-16-17-18-19-21-22-23-24-27-30-32 mm
- 1 flessometro 5 m
- 18 chiavi combinate 6-7-8-9-10-11-12-13-14-15-16-17-18-19-21-22-24-27 mm
- 7 chiavi poligonali curve 6x7-8x9-10x11-12x13-14x15-16x17-18x19 mm
- 1 adattatore a sgancio rapido 1/4" per chiavi a cricchetto 10 mm
- 1 adattatore a sgancio rapido 3/8" per chiavi a cricchetto 13 mm
- 1 adattatore a sgancio rapido 1/2" per chiavi a cricchetto 19 mm
- 12 chiavi combinate a cricchetto reversibile 8-9-10-11-12-13-14-15-16-17-18-19 mm
- 31 inserti colorati con portainseriti magnetico in astuccio tascabile ● ○ ⊗ ⊕ ⊙ ⊚
- 1 pinze regolabili cerniera chiusa 250 mm
- 1 tronchesi a taglianti diagonali 160 mm
- 1 pinza universale 180 mm
- 1 pinza becchi piatti dritti 160 mm
- 5 giravite lama piatta ● 3x75-4x100-5,5x100-6,5x150-8x150 mm
- 1 giravite nano lama piatta ● 6,5x30 mm
- 3 giravite Phillips® ● 4,5x80-6x100-8x150 mm
- 1 giravite nano Phillips® ● 6x30 mm
- 4 chiavi maschio con impugnatura per viti con impronta Torx® ○ T20-T25-T27-T30

Beta N.

TR

- 956E
- 910AL
- 920PE
- 920FTX
- 920TX
- 920XZN
- 920AL
- 1692/5
- 42NEW
- 90
- 123Q1/4
- 123Q3/8
- 123Q1/2
- 142
- 860MIX/A31
- 1048
- 1082BM
- 1150BM
- 1162BM
- 1290
- 1290N
- 1292
- 1292N
- 1297TX



5988L/4M 3.110,00 059881088

Assortimento consigliato in abbinamento con C24S - C24SA - C24SA-XL - C24SL - C24SL/CAB - C37 - C39 - C39T - C39SM - C39MD - RSC55 - C59

Universali



M01



M30



M213



M230



M129



M100

N. pezzi/Descrizione

22	chiavi combinate 6-7-8-9-10-11-12-13-14-15-16-17-18-19-20-21-22-24-27-30-32-36 mm	42NEW	M01
11	chiavi a forchetta 6x7-8x9-10x11-12x13-14x15-16x17-18x19-20x22-21x23-24x27-30x32 mm	55	M30
11	chiavi poligonali curve 6x7-8x9-10x11-12x13-14x15-16x17-18x19-20x22-21x23-24x27-30x32 mm	90	M30
9	chiavi maschio esagonale piegate con estremità sferica \varnothing 1,5-2-2,5-3-4-5-6-8-10 mm	96BPC/SC9	M30
6	giravite lama piatta \bullet 2,5x50-3x75-4x100-5,5x125-6,5x150-8x200 mm	1201E	M213
1	giravite per viti a testa con intaglio \bullet 4x30 mm	1201EN	M213
4	giravite Phillips® \bullet PH0x60-PH1x80-PH2x100-PH3x150 mm	1202E	M213
1	giravite Phillips® \bullet PH1x30 mm	1202EN	M213
12	chiavi maschio con impugnatura per viti con impronta Torx® \bullet T6-T7-T8-T9-T10-T11-T15-T20-T25-T27-T30-T40-T45	1207E/TX	M213
1	giravite cercafase \bullet	1253	M213
3	punzoni \varnothing 2-3-4 mm	30	M230
6	cacciaspina \varnothing 2-3-4-5-6-8 mm	31	M230
1	bulino \varnothing 4 mm	32	M230
1	scalpelli piatti 150 mm	34	M230
2	scalpelli piatti nervati 200-250 mm	35	M230
1	ugnetti 125 mm	36	M230
1	martello tipo tedesco 500 g	1370	M230
1	mazzuola con battenti in materiale plastico \varnothing 35 mm	1390	M230
1	flessometro 3 m	1692	M230
1	magnete telescopico con testa flessibile	1712TF	M230
1	lima 200 mm	1719BMA...Q	M230
1	lima 200 mm	1719BMA...T	M230
1	lima 200 mm	1719BMA...P	M230
1	lima 200 mm	1719BMA...M	M230
1	lima 200 mm	1719BMA...R	M230
1	spazzola fili d'acciaio	1737NX	M230
1	cutter con lama a settori 18 mm	1771	M230
1	pinze becchi dritti per anelli elastici, per fori \varnothing 180 mm	1032	M129
1	pinze becchi piegati per anelli elastici, per fori \varnothing 170 mm	1034	M129
1	pinze becchi dritti per anelli elastici, per alberi \bullet 175 mm	1036	M129
1	pinze becchi piegati per anelli elastici, per alberi \bullet 175 mm	1038	M129
1	pinze regolabili cerniera chiusa 250 mm	1048	M129
1	pinza autobloccante 240 mm	1052	M129

Beta N.

TR

N. pezzi/Descrizione

1	tronchese a taglienti diagonali \leq 160 mm	1082BM	M129
1	tenaglie per cementisti 220 mm	1098	M129
1	cesoia a lame larghe diritte 250 mm	1112	M129
1	forbici per elettricisti lame dritte	1128BM	M129
1	pinza universale \equiv 180 mm	1150BM	M129
1	pinza a becchi mezzotondi dritti \bullet 160 mm	1166BM	M129
1	pinza a becchi mezzotondi piegati \bullet 160 mm	1168BM	M129
1	bussola portainseri	895/1	M100
1	bussola portainseri	895/3	M100
1	bussola portainseri	895/6	M100
13	chiavi a bussola esagonali 1/4" \varnothing 4-4,5-5-5,5-6-7-8-9-10-11-12-13-14 mm	900	M100
9	chiavi a bussola a mano lunghe bocca esagonale \varnothing 5-6-7-8-9-10-11-12-13 mm	900L	M100
5	chiavi a bussola maschio esagonale 1/4" \varnothing 3-4-5-6-7 mm	900ME	M100
4	chiavi a bussola a giravite per viti con intaglio \bullet 0,8x4-1x5,5-1,2x6,5-1,2x8 mm	900LP	M100
4	chiavi a bussola a giravite per viti con impronta a croce Phillips® \bullet PH1-PH2-PH3-PH4	900PH	M100
7	chiavi a bussola a giravite maschio per viti con impronta Torx® \bullet T10-T15-T20-T25-T27-T30-T40	900TX	M100
1	prolunga - 1/4" 50 mm	900/20	M100
1	prolunga - 1/4" 100 mm	900/20L	M100
1	prolunga - 1/4" 150 mm	900/21	M100
1	snodo 1/4"	900/25	M100
1	quadro con impugnatura 1/4"	900B/30	M100
1	quadro scorrevole 1/4"	900/42	M100
1	cricchetto reversibile 1/4" \bullet	900/55	M100
21	chiavi a bussola esagonali 1/2" \varnothing 8-10-11-12-13-14-15-16-17-18-19-20-21-22-23-24-26-27-28-30-32 mm	920A	M100
1	raccordo con attacco quadro 125 mm	920/15	M100
1	snodo 1/2" 250 mm	920/25	M100
1	prolunga angolare - 1/2"	920AN/125	M100
1	prolunga angolare - 1/2"	920AN/250	M100
1	quadro maschio 1/2" con spina scorrevole	920/42	M100
1	cricchetto reversibile 1/2" \bullet	920/55	M100
8	chiavi a bussola 1/2" per viti con teste a profilo Torx® \bullet 10-12-14-16-18-20-22-24 mm	920FTX	M100
11	chiavi a bussola a mano lunghe bocca esagonale \varnothing 10-12-13-14-15-16-17-18-19-21-22 mm	920AL	M100

Beta N.

TR



5988U6/M 2.590,00 059881430

Assortimento consigliato in abbinamento con C24S da 8 cassette - C24S/A da 8 cassette - C24SA-XL da 8-9 cassette
C28 - C37 da 8 cassette - C39 da 8 cassette - C39SM - C39MD - C55 - C59B

Elettrotecnica



MB65



MB64



MB63

N. pezzi/Descrizione

- 1 pinza autobloccante 240 mm
- 1 martello tipo tedesco 500 g
- 1 mazzuola con battenti in materiale plastico Ø 35 mm
- 1 lima 200 mm
- 1 lima 200 mm
- 1 lima 200 mm
- 1 lima 200 mm
- 1 lima 200 mm
- 1 scalpelli piatti nervati 200 mm
- 1 pinze becchi dritti per anelli elastici, per fori ○ 180 mm
- 1 pinze becchi piegati per anelli elastici, per fori ○ 170 mm
- 1 pinze becchi dritti per anelli elastici, per alberi ● 175 mm
- 1 pinze becchi piegati per anelli elastici, per alberi ● 175 mm
- 1 tronchesi a grande effetto taglienti diagonali † 160 mm
- 1 pinza universale = 180 mm
- 1 pinza a becchi mezzotondi dritti ● 160 mm
- 9 chiavi maschio esagonale piegate con estremità sferica ○
- 1 giravite prensile lama piatta ●
- 1 giravite prensile Phillips® ⊕

Beta N.	TR
1052	MB65
1370	MB65
1390	MB65
1719BMA...Q	MB65
1719BMA...P	MB65
1719BMA...T	MB65
1719BMA...M	MB65
1719BMA...R	MB65
35	MB65
1032	MB65
1034	MB65
1036	MB65
1038	MB65
1084BM	MB65
1150BM	MB65
1166BM	MB65
96BPC/SC9	MB63
1250	MB63
1251	MB63

N. pezzi/Descrizione

- 1 giravite cercafase ●
- 6 chiavi a bussola esagonale con impegnatura ○ 5,5-6-7-8-10-13 mm
- 4 giravite Phillips® 1000V ⊕ PH0x60-PH1x80-PH2x100-PH3x150 mm
- 6 giravite lama parallela 1000V ● 2,5x75-3x100-4x100-5,5x125-6x150-8x175 mm
- 31 inserti colorati con portainseri magnetico in astuccio tascabile
- 1 portainseri magnetico isolato ®
- 8 chiavi a forchetta 6x7-8x9-10x11-12x13-14x15-16x17-18x19-20x22 mm
- 1 pinze regolabili a cerniera chiusa 250 mm
- 1 tronchesi a taglienti diagonali 1000V † 140 mm
- 1 forbici per elettricisti lame diritte con svasatore
- 1 tagliacavi 230 mm
- 1 pinze spellafili ‡ 160 mm
- 1 pinza universale 1000V = 180 mm
- 1 pinze a becchi mezzotondi lunghissimi 1000V ● 160 mm
- 1 pinze a becchi mezzotondi lunghissimi piegati ● 160 mm
- 1 chiave regolabile a rullino 1000V 250 mm
- 1 cutter 1000V
- 1 pinzetta a molla a punte curve arrotondate 1000V
- 1 pinza per capicorda preisolati

Beta N.	TR
1253	MB63
943MQ	MB63
1272MQ	MB63
1274MQ	MB63
860MIX/A31	MB63
850MQ	MB63
55	MB64
1048MQ	MB64
1082MQ	MB64
1128BSX	MB64
1132MQ	MB64
1142MQ	MB64
1150MQ	MB64
1166MQ	MB64
1168MQ	MB64
110MQ	MB64
1777MQ	MB64
993MQ	MB64
1602	MB64

5980ET/A

assortimento di 70 utensili

Elettrotecnica



7,9 kg

N. pezzi/Descrizione

1	bulino Ø 4 mm	32
1	scalpelli piatti nervati 150 mm	35
8	chiavi a forchetta 6x7 - 8x9 - 10x11 - 12x13 - 14x15 - 16x17 - 18x19 - 20x22 mm	55/B8
8	chiavi maschio esagonale, tipo lungo Ø 1,5÷12 mm	96LC/SC8
1	chiave regolabile a rullino 200 mm	111
1	portainseri magnetico isolato	850MQ
10	inserti con portainseri magnetico	860MIX/A10
1	pinze regolabili a cerniera chiusa 250 mm	1048MQ
1	tronchesi a taglienti diagonali 160 mm	1082BM
1	forbici per elettricisti lame diritte con svasatore	1128BSX
1	tagliacavo 170 mm	1132BM
1	pinza universale 180 mm	1150BM
1	pinza a becchi mezzotondi dritti 160 mm	1166BM
1	pinza a becchi mezzotondi piegati 160 mm	1168BM
1	giravite prensile lama piatta 4x125 mm	1250
1	giravite prensile Phillips® PH1x150 mm	1251

Beta N. N. pezzi/Descrizione

1	giravite cercafase	1253
5	giravite lama piatta 2,5x75 - 3,5x100 - 5,5x125 - 6,5x150 mm	1201E
1	giravite per viti a testa con intaglio 4x30 mm	1201EN
4	giravite Phillips® PH0x60 - PH1x120 - PH2x150 - PH3x150 mm	1202E
1	giravite Phillips® PH2x30 mm	1202EN
4	giravite Phillips® 1000V PH0x60 - PH1x80 - PH2x100 - PH3x150 mm	1272MQ
5	giravite lama parallela 1000V 5,5x125 - 3x100 - 4x100 - 6,5x150 - 8x175 mm	1274MQ
1	scalpello piatto con tagliente laterale	1343
1	martello tipo tedesco 300 g	1370
1	mazzuola con battenti in materiale plastico Ø 35 mm	1390
1	pinza per capicorda preisolati	1602
1	nastro isolante in PVC 25 m	BMESB1925NE
1	flessometro 5 m	1692
1	lima 200 mm	1719BMA...M
1	lima 200 mm	1719BMA...R
1	seghetto	1725
1	coltello a serramanico	1777BM



5980ET/A 765,00 059801083

Assortimento consigliato in abbinamento con C12 - 2032TV - 2028/VV

5980ET/B

assortimento di 64 utensili e 200 collari

Elettrotecnica



8,7 kg

N. pezzi/Descrizione

- 3 cacciaspina Ø 2 - 3 - 4 mm
- 1 bulino Ø 4 mm
- 1 scalpelli piatti 150 mm
- 8 chiavi a forchetta 6x7 - 8x9 - 10x11 - 12x13 - 14x15 - 16x17 - 18x19 - 20x22 mm
- 9 chiavi maschio esagonale piegate con estremità sferica
○ 1,5 - 2 - 2,5 - 3 - 4 - 5 - 6 - 8 - 10 mm
- 1 sbavatore a raschietto 150 mm
- 6 chiavi a bussola esagonale con impugnatura 1000V
○ 5,5 - 6 - 7 - 8 - 10 - 13 mm
- 1 pinze regolabili a cerniera chiusa 250 mm
- 1 tronchesi a taglienti diagonali 1000V ⚡ 160 mm
- 1 forbici per elettricisti lame diritte con svasatore
- 1 tagliacavi 230 mm
- 1 pinze spellafili ⚡ 160 mm
- 1 pinza universale 1000V = 180 mm
- 1 pinze a becchi mezzotondi lunghissimi 1000V ● 160 mm
- 1 giravite cercafase ●
- 3 giravite Phillips® 1000V ⊕ PH0x60 - PH1x80 - PH2x100 mm
- 4 giravite lama parallela 1000V ● 3x100 - 4x100 - 5,5x125 - 6,5x150 mm

Beta N.

- 31
- 32
- 34
- 55/B8
- 96BPC/SC9
- 345SB
- 943MQ/S6
- 1048MQ
- 1082MQ
- 1128BSX
- 1132MQ
- 1142MQ
- 1150MQ
- 1166MQ
- 1253
- 1272MQ
- 1274MQ

N. pezzi/Descrizione

- 1 martello tipo tedesco 300 g
- 1 mazzuola con battenti in materiale plastico Ø 35 mm
- 1 pinza per capicorda preisolati
- 1 riga flessibile graduata 250 mm
- 1 punta per tracciare 250 mm
- 1 flessometro 5 m
- 1 livella in alluminio 200 mm
- 1 scalpello per elettricisti 10x200 mm
- 1 tracciolinea
- 1 specchietto flessibile 600 mm
- 1 lime a taglio mezzodolce 200 mm
- 1 lime a taglio mezzodolce 200 mm
- 1 tenditore per molle
- 1 seghetto
- 1 pennello
- 1 pinza per collari in Nylon
- 1 oliatore in plastica 80 cc
- 100 fascette in nylon 3,6x200 mm
- 100 fascette in nylon 4,8x300 mm
- 1 cutter con lama a settori
- 1 saldatore 30 W
- 1 torcia LED per ispezioni

Beta N.

- 1370
- 1390
- 1602
- 1682
- 1688
- 1692
- 1696
- 1701NE3
- 1705
- 1715FL/A
- 1719BMA8/M
- 1719BMA8/R
- 1723
- 1726BM
- 1738
- 1743
- 1755
- 1748N
- 1748N
- 1771BM
- 1814M
- 1833XS/2



5980ET/B 1.047,00 059801084

Assortimento consigliato in abbinamento con C12 - 2029/VV - 2033P/VV - 2036TV

5980MQ

assortimento di 46 utensili

Elettrotecnica



7 kg

N. pezzi/Descrizione

- 7 chiavi a forchetta 1000V 10 - 12 - 13 - 14 - 17 - 19 - 22 mm
- 1 chiave regolabile a rullino 1000V 250 mm
- 6 chiavi a bussola esagonale con impegnatura
○ 5,5 - 6 - 7 - 8 - 10 - 13 mm
- 4 chiavi a T maschio esagonale ○ 4 - 5 - 6 - 8 mm
- 1 pinzetta a molla a punte curve arrotondate 1000V
- 1 pinze regolabili a cerniera chiusa 250 mm
- 1 tronchesi a taglienti diagonali 1000V 160 mm
- 1 forbici per elettricisti
- 1 pinze spellafili 160 mm
- 1 pinza universale 1000V 180 mm
- 1 pinze a becchi piatti lunghissimi piegati 160 mm

Beta N.

- 52MQ
- 110MQ
- 943MQ
- 951MQ
- 993MQ
- 1048MQ
- 1082MQ
- 1128MQ
- 1142MQ
- 1150MQ
- 1164MQ

N. pezzi/Descrizione

- 1 pinze a becchi mezzotondi lunghissimi 1000V 160 mm
- 1 giravite cercafase
- 4 giravite Phillips® 1000V
● PH0x60 - PH1x80 - PH2x100 - PH3x150 mm
- 5 giravite lama parallela 1000V
● 3x100 - 4x100 - 5,5x125 - 6,5x150 - 8x175 mm
- 1 martello tipo tedesco 300 g
- 1 mazzuola con battenti in materiale plastico Ø 35 mm
- 1 flessometro 5 m
- 1 200 mm
- 1 miniseghetto 1000V
- 2 cutter 1000V
- 1 saldatore 30 W
- 1 torcia LED ad alta luminosità, fino a 500 Lumen
- 1 tester combinato di tensione e di continuità

Beta N.

- 1166MQ
- 1253
- 1272MQ
- 1274MQ
- 1370
- 1390
- 1692
- 1701NE/3
- 1725MQ
- 1777MQ
- 1814M
- 1833S
- 1847P



5980MQ 1.420,00 059801257

Assortimento consigliato in abbinamento con 2029/VV

5988 VHB-MQ

assortimento di 66 utensili in vassoio morbido in EVA

Elettrotecnica



M49



M108



M161

N. pezzi/Descrizione

- 12 chiavi a forchetta 1000V 7-8-10-11-12
13-14-15-16-17-19-22 mm
- 12 chiavi poligonali semplici 7-8-10-11-12-13
14-15-16-17-19-22 mm
- 4 chiavi a bussola maschio esagonale \odot 4-5-6-8 mm
- 11 chiavi a bussola poligonali
 \odot 7-8-10-11-12-13-14-15-16-17-19 mm
- 6 chiavi a bussola maschio per viti con impronta Torx® \odot T15-
T20-T25-T27-T30-T40
- 2 chiavi a bussola maschio a profilo XZN® \odot 8-10 mm
- 1 prolunga quadro maschio e femmina 3/8" 125 mm
- 1 prolunga quadro maschio e femmina 3/8" 250 mm
- 1 quadro maschio 3/8", a T

Beta N.

TR

- 52MQ **M49**
- 89MQ **M49**
- 910MQ/PE **M108**
- 910MQ/B **M108**
- 910MQ/TX **M108**
- 910MQ/XZN **M108**
- 910MQ/21 **M108**
- 910MQ/22 **M108**
- 910MQ/T **M108**

N. pezzi/Descrizione

- 1 cricchetto reversibile con attacco quadro maschio 3/8"
- 1 forbici per elettricisti
- 1 pinze regolabili a cerniera chiusa 250 mm
- 1 tronchese a taglienti diagonali 1000V \nless 160 mm
- 1 pinza universale 1000V \equiv 180 mm
- 1 pinze a becchi piatti lunghissimi dritti \equiv 160 mm
- 1 pinze a becchi piatti lunghissimi piegati \equiv 160 mm
- 4 giravite Phillips® 1000V
 \odot PH0x60 - PH1x80 - PH2x100 - PH3x150 mm
- 4 giravite lama parallela 1000V
 \bullet 2,5x75 - 3x100 - 4x100 - 5,5x125 mm
- 1 coltello spellacavi isolato

Beta N.

TR

- 910MQ/55 **M108**
- 1128MQ **M161**
- 1048MQ **M161**
- 1082MQ **M161**
- 1150MQ **M161**
- 1162MQ **M161**
- 1164MQ **M161**
- 1272MQ **M161**
- 1274MQ **M161**
- 1777MQ/U **M161**



5988 VHB-MQ 2.350,00 059880300

Assortimento consigliato in abbinamento con C23ST - C24S - C24SA - C24SA-XL - C24SL - C24SL/CAB
C28 - C37 - C39 - C39SM - C39MD - C39T - RSC55 - C59

5980EL/A

assortimento di 57 utensili

Elettronica



2,6 kg

N. pezzi/Descrizione

- 13 chiavi a forchetta piccole 4÷14 mm
- 9 chiavi maschio esagonale piegate \varnothing 1,5÷10 mm
- 1 pinzetta punte fini curve 130 mm
- 1 pinzetta punte fini diritte 150 mm
- 1 pinzetta becchi dritti incrociati 155 mm
- 1 forbici per elettricisti lame diritte
- 1 pinza spellafili \updownarrow 160 mm
- 1 pinza a becchi mezzotondi dritti \bullet 160 mm
- 1 pinza a becchi piatti lunghi —
- 1 pinza a becchi mezzotondi lunghi piegati \bullet
- 1 pinza universale per elettronica \bullet
- 1 tronchese a taglienti diagonali rasi ζ
- 1 tronchese a taglienti diagonali normali ζ
- 1 giravite prensile lama piatta \bullet 4x125 mm

Beta N.

- 73/B13
- 96N/SC9
- 991
- 992
- 998
- 1128BMX
- 1142BM
- 1166BM
- 1172BM
- 1178BM/P
- 1178BM
- 1185BM
- 1188BM
- 1250

N. pezzi/Descrizione

- 1 giravite prensile Phillips® \oplus PH0x125 mm
- 8 microgiraviti
- 1 martello tipo tedesco 200 g
- 1 flessometro 5 m
- 1 specchietto telescopico
- 3 lime ad ago
- 1 tenditore per molle
- 1 pennello
- 1 oliatore a stilo
- 1 cutter con lama a settori
- 1 pinzetta autobloccante
- 1 saldatore 25 W
- 1 pompetta succhiastagno
- 1 torcia LED per ispezioni

Beta N.

- 1251
- 1257LPH/S8
- 1370
- 1692
- 1715
- 1720/S3
- 1723
- 1738
- 1756
- 1771
- 1002
- 1814M
- 1830T
- 1833XS/2



5980EL/A 753,00 059801081

Assortimento consigliato in abbinamento con 2028/IV - 2032TV - 2033P/IV

5980EL/B

assortimento di 98 utensili

Elettronica



4,8 kg

N. pezzi/Descrizione

- 13 chiavi a forchetta piccole 4+14 mm
- 9 chiavi maschio esagonale piegate \varnothing 1,5+10 mm
- 8 chiavi maschio con impronta Torx® \odot T9 - T10 - T15 - T20 - T25 - T27 - T30 - T40
- 1 chiave regolabile a rullino 150 mm
- 18 assortimento 13 bussole e 5 accessori 1/4"
- 1 pinzetta a molla a punte fini diritte 130 mm
- 1 pinzetta punte fini curve 130 mm
- 1 pinzetta a molla a punte corte finissime 120 mm
- 1 forbici per elettricisti lame diritte
- 1 pinza spellafili frontale autoregolabile 170 mm
- 1 pinza universale \equiv 180 mm
- 1 pinza a becchi piatti lunghi \equiv 140 mm
- 1 pinza a becchi mezzotondi lunghi lisci \bullet 140 mm
- 1 pinza a becchi mezzotondi lunghi piegati \bullet 140 mm
- 1 tronchese a taglienti diagonali rasi becchi arrotondati ζ 120 mm
- 1 tronchese a taglienti diagonali rasi becchi assotigliati ζ 120 mm
- 1 tronchese a taglienti frontali obliqui rasi ζ
- 8 microgiraviti
- 1 giravite cercafase \bullet
- 1 giravite nano lama piatta \bullet 6,5x30 mm

Beta N.

- 73/B13
- 96/SC9
- 97TX/BG8
- 111
- 900/C13-5
- 990
- 991
- 999A
- 1128BMX
- 1149F
- 1150BM
- 1172BM
- 1177BM
- 1178BM/P
- 1184BM
- 1186BM
- 1191BM
- 1257LPH/S8
- 1253
- 1290N

N. pezzi/Descrizione

- 3 giravite Phillips® \oplus PH0x60 - PH1x80 - PH2x100 mm
- 2 giravite nano Phillips® \oplus PH1x30 - PH2x30 mm
- 5 giravite lama parallela \bullet 2,5x60 - 3x75 - 4x100 - 5x125 - 6,5x150 mm
- 1 martello tipo tedesco 200 g
- 1 riga flessibile graduata 150 mm
- 1 punta per tracciare 220 mm
- 1 flessometro 5 m
- 1 specchietto telescopico 670 mm
- 1 lime ad ago \bullet
- 1 lime ad ago \blacktriangle
- 1 lime ad ago \blacksquare
- 1 tenditore per molle
- 1 pennello
- 1 oliatore a stilo
- 1 cutter con lama a settori
- 1 coltello a serramanico
- 1 pinzetta autobloccante
- 1 saldatore 25W
- 1 pompetta succhiastagno
- 1 torcia LED per ispezioni

Beta N.

- 1292
- 1292N
- 1294
- 1370
- 1682
- 1688
- 1692
- 1715
- 1720R
- 1720T
- 1720P
- 1723
- 1738
- 1756
- 1771BM
- 1777BM
- 1002
- 1814M
- 1830T
- 1833XS/2

5980EL/B 1.060,00 059801082

Assortimento consigliato in abbinamento con 2029/VV - 2033P/VV - 2036TV

5980ID

assortimento di 35 utensili

Idraulica



11,6 kg

N. pezzi/Descrizione

- 1 scalpelli piatti 150 mm
- 1 scalpelli piatti nervati 200 mm
- 12 chiavi a forchetta 6x7 - 8x9 - 10x11 - 12x13 - 14x15 - 16x17
18x19 - 20x22 - 21x23 - 24x27 - 25x28 - 30x32 mm
- 1 chiave regolabile a rullino 250 mm
- 1 tagliatubi per rame e leghe leggere Ø 3÷30 mm
- 1 giratubi svedese 320 mm
- 1 pinze regolabili cerniera chiusa 250 mm
- 1 pinza autobloccante 240 mm
- 1 cesoia a lame larghe diritte 300 mm
- 1 forbici per elettricisti lame diritte

Beta N.

- 34
- 35
- 55/S12X
- 111
- 334
- 374
- 1048
- 1052
- 1112
- 1128BMX

N. pezzi/Descrizione

- 1 pinze universali a grande effetto, finitura industriale = 180 mm
- 4 giravite lama piatta 3x75 - 4x100 - 5,5x150 - 8x150 mm
- 2 giravite Phillips® PH1x80 - PH2x100 mm
- 1 martello tipo tedesco 300 g
- 1 metro pieghevole in fibra 2 m
- 1 flessometro 5 m
- 1 livella in alluminio 200 mm
- 1 lima 200 mm
- 1 seghetto
- 1 spazzola fili d'acciaio

Beta N.

- 1150GBM
- 1201E
- 1202E
- 1370
- 1690F
- 1692
- 1696
- 1719BMA...M
- 1725
- 1737NX



5980ID 489,00 059801085

Assortimento consigliato in abbinamento con 2009N/BV

5902MT

assortimento di 106 utensili per macchine agricole, edili e movimento terra

Autoriparazione



28,6 kg

N. pezzi/Descrizione

- 2 punzoni Ø 3 - 4 mm
- 2 cacciapina Ø 6 - 8 mm
- 1 bulino Ø 4 mm
- 2 scalpelli piatti nervati 150 - 200 mm
- 18 chiavi combinate 6÷14 - 17 - 19 - 22 - 24 - 27 - 30 - 32 - 36 - 41 mm
- 10 chiavi poligonali curve 6x7 - 8x9 - 10x11 - 12x13 - 14x15 - 16x17 - 18x19 - 20x22 - 24x27 - 30x32 mm
- 10 chiavi maschio esagonale piegate Ø 1,5÷12 mm
- 17 chiavi a bussola esagonali 1/2"
 - 10÷22 - 24 - 27 - 30 - 32 mm
- 1 prolunga - 1/2" 125 mm
- 1 prolunga - 1/2" 255 mm
- 1 snodo 1/2"
- 1 quadro maschio 1/2" con spina scorrevole
- 1 cricchetto con quadro scorrevole 1/2" Ⓞ
- 11 chiavi a bussola esagonali 3/4" ○ 22 - 24 - 27 - 30 - 32 - 36 - 41 - 46 - 50 - 55 - 60 mm
 - 1 prolunga - 3/4" 200 mm
- 1 quadro maschio snodato 3/4" con impugnatura
- 1 quadro maschio 3/4" con spina scorrevole
- 1 cricchetto reversibile 3/4" Ⓞ
- 1 leva con estremità a punta e a becco

Beta N.

- 30
- 31
- 32
- 35
- 42NEW
- 90
- 96N/B10
- 920A
- 920/21
- 920/22
- 920/25
- 920/42
- 920/50
- 928A
- 928/21
- 928/36A
- 928/42
- 928/55
- 964

N. pezzi/Descrizione

- 1 pinze regolabili cerniera chiusa 250 mm
- 1 pinza autobloccante ganasce sagomate
- 1 tronchesi a grande effetto, a taglienti diagonali, finitura industriale 160 mm
- 1 forbici per elettricisti lame dritte
- 1 pinze universali a grande effetto, finitura industriale = 180 mm
- 1 pinze a becchi mezzotondi lunghissimi, diritti zigrinati, impugnatura bimatereale, finitura industriale ● 160 mm
- 4 giravite lama piatta con esagono di manovra ● 6,5x150 - 8x175 - 10x200 - 12x250 mm
- 3 giravite Phillips® con esagono di manovra ⊕ PH2x150 - PH3x175 - PH4x200 mm
- 1 martello testa tonda penna sferica 900 g
- 1 mazzuola con battenti in materiale plastico Ø 35 mm
- 1 spessimetro
- 1 raschietto a tre taglienti 200 mm
- 5 serie di 5 lime 200 mm
- 1 seghetto

Beta N.

- 1048
- 1055
- 1084GBM
- 1128BMX
- 1150GBM
- 1166GBM
- 1260E
- 1262E
- 1377
- 1390
- 1708/20
- 1717B
- 1719BMA...S5
- 1725



5902MT 1.850,00 059021053

Assortimento consigliato in abbinamento con C22S - C23S - C23SC - C39T

5902MT/AS

assortimento di 99 utensili per macchine movimento terra (CATERPILLAR)

Autoriparazione



27,3 kg

N. pezzi/Descrizione

Beta N.

N. pezzi/Descrizione

Beta N.

- 2 punzoni Ø 3 - 4 mm
- 2 cacciaspina Ø 6 - 8 mm
- 1 bulino Ø 4 mm
- 2 scalpelli piatti nervati 150 - 200 mm
- 20 chiavi combinate 1/4+1.1/2"
- 6 chiavi poligonali curve 1/4x5/16 - 3/8x7/16 - 1/2x9/16 5/8x3/4 - 11/16x13/16 - 7/8x15/16"
- 11 chiavi maschio esagonale piegate O 3/64+3/8"
- 10 chiavi a bussola poligonali □ 1/2" O 7/16 - 1/2 - 9/16 5/8 - 11/16 - 3/4 - 13/16 - 7/8 - 15/16 - 1"
- 1 prolunga - 1/2" 125 mm
- 1 prolunga - 1/2" 255 mm
- 1 snodo 1/2"
- 1 quadro maschio 1/2" con spina scorrevole
- 1 cricchetto con quadro scorrevole 1/2" Ⓢ
- 12 chiavi a bussola esagonali O □ 3/4", 7/8 - 15/16 - 1 - 1.1/16 - 1.1/8 - 1.1/4 - 1.5/16 1.1/2 - 1.5/8 - 1.11/16 - 1.7/8 - 2"
- 1 prolunga - 3/4" 200 mm
- 1 quadro maschio snodato 3/4" con impugnatura
- 1 quadro maschio 3/4" con spina scorrevole
- 1 cricchetto reversibile 3/4" Ⓢ
- 1 leva con estremità a punta e a becco

- 30
- 31
- 32
- 35
- 42AS
- 90AS
- 96AS/B11
- 920AS
- 920/21
- 920/22
- 920/25
- 920/42
- 920/50
- 928AS
- 928/21
- 928/36A
- 928/42
- 928/55
- 964

- 1 pinze regolabili cerniera chiusa 250 mm 1048
- 1 pinza autobloccante ganasce sagomate 1055
- 1 tronchesi a grande effetto, a taglienti diagonali, finitura industriale 160 mm 1084GBM
- 1 forbici per elettricisti lame dritte 1128BMX
- 1 pinze universali a grande effetto, finitura industriale = 180 mm 1150GBM
- 1 pinze a becchi mezzotondi lunghissimi, diritti zigginati, impugnatura bimatereale, finitura industriale ● 160 mm 1166GBM
- 4 giravite lama piatta con esagono di manovra ● 6,5x150 - 8x175 - 10x200 - 12x250 mm 1260E
- 3 giravite Phillips® con esagono di manovra ⚙ PH2x150 - PH3x175 - PH4x200 mm 1262E
- 1 martello testa tonda penna sferica 900 g 1377
- 1 mazzuola con battenti in materiale plastico Ø 35 mm 1390
- 1 spessimetro 150 - 200 mm 1708/20
- 1 raschietto a tre taglienti 200 mm 1717B
- 5 serie di 5 lime 200 mm 1719BMA...S5
- 1 seghetto 1725



5902MT/AS 1.915,00 059021054

Assortimento consigliato in abbinamento con C22S - C23S - C23SC - C39T

5904VG/2M

assortimento di 170 utensili in vassoio morbido in EVA

Autoriparazione



M05 M06 VP/M3



M50 M55 M86



M208 M85 M234



M83 M136 M145

N. pezzi/Descrizione

- 16 chiavi combinate 6÷21 mm
- 5 chiavi combinate 22 - 24 - 27 - 30 - 32 mm
- 8 chiavi maschio esagonale con impugnatura
○ 2-2,5-3-4-5-6-7-8 mm
- 5 chiavi maschio con impugnatura per viti con impronta Torx®
⊕ T10-T15-T20-T25-T30
- 7 inserti maschio esagonale ○ 4-5-6-7-8-10-12 mm
- 7 inserti maschio esagonale ○ 4-5-6-7-8-10-12 mm
- 5 inserti a profilo XZN® ○ 5-6-8-10-12 mm
- 5 inserti a profilo XZN® ○ 5-6-8-10-12 mm
- 7 inserti per viti con impronta Torx®
⊕ T20-T25-T30-T40-T45-T50-T55
- 6 inserti per viti con impronta Torx®
⊕ T25-T30-T40-T45-T50-T55
- 7 inserti per viti con impronta
Tamper Resistant Torx® ⊕ T20-T25-T30-T40-T45-T50-T55
- 1 bussole portainseriti per 867
- 1 bussole portainseriti per 867
- 5 giravite lama piatta ● 3x75 - 3,5x100 - 4x125 - 5,5x150 -
6,5x150 mm
- 3 giravite per viti con impronta a croce Phillips®
⊕ PH0x60 - PH1x80 - PH2x100 mm
- 1 giravite nano lama piatta ● 4x30 mm
- 1 giravite nano Phillips® ⊕ PH1x30 mm
- 5 inserti colorati per avvitatori per viti a testa con intaglio
● 0,5x3 - 0,6x4,5 - 0,8x5,5 - 1x5,5 - 1,2x6,5 mm
- 8 inserti colorati maschio esagonale per avvitatori
○ 2 - 2,5 - 3 - 4 - 5 - 6 - 8 - 10 mm
- 5 inserti colorati per avvitatori per viti con impronta a croce
Phillips® ⊕ PH0 - PH1 - PH2 - PH3 - PH4

Beta N. TR

- 42NEW M05
- 42NEW M06
- 96T M50
- 97TTX M55
- 867PE M86
- 867PE/L M86
- 867XZN M86
- 867XZN/L M86
- 867TX M86
- 867TX/L M86
- 867RTX M86
- 867/1 M86
- 867/2 M86
- 1260 M208
- 1262 M208
- 1260N M208
- 1262N M208
- 860LP M85
- 860PE M85
- 860PH M85

N. pezzi/Descrizione

- 4 inserti colorati per avvitatori per viti con impronta a croce
Pozidriv® - Supadriv® ⊕ PZ1 - PZ2 - PZ3 - PZ4
- 11 inserti colorati per avvitatori per viti con impronta Torx® ⊕ T6-
T7-T8-T9-T10-T15-T20-T25-T27-T30-T40
- 8 inserti colorati per avvitatori per viti con impronta Tamper
Resistant Torx® ⊕ T9-T10-T15-T20-T25-T27-T30-T40
- 1 portainseriti a sgancio rapido con impugnatura 230 mm
- 1 cricchetto reversibile portainseriti 100 mm
- 2 scalpelli piatti nervati 100 - 200 mm
- 1 martello tipo tedesco 300 g
- 1 mazzuola con battenti in materiale plastico Ø 35 mm
- 1 prolunga angolare - 1/2" 125 mm
- 1 prolunga angolare - 1/2" 250 mm
- 1 snodo 1/2"
- 1 quadro maschio 1/2" con spina scorrevole
- 1 cricchetto reversibile 1/2" ⊕
- 19 chiavi a bussola esagonali 1/2"
○ 10÷24 - 26 - 27 - 30 - 32 mm
- 1 pinza universale = 180 mm
- 1 pinza a becchi mezzotondi dritti ● 160 mm
- 1 pinze becchi dritti per anelli elastici, per fori ○ 180 mm
- 1 pinze becchi piegati per anelli elastici, per fori ○ 170 mm
- 1 pinze becchi dritti per anelli elastici, per alberi ● 175 mm
- 1 pinze becchi piegati per anelli elastici, per alberi ● 175 mm
- 1 prolunga portainseriti magnetica 80 mm
- 1 raccordi per avvitatori ■ 1/4 - □ 1/4

Beta N. TR

- 860PZ M85
- 860TX M85
- 860RTX M85
- 851SR M85
- 860/55 M85
- 35 M234
- 1370 M234
- 1390 M234
- 920AN/125 M83
- 920AN/250 M83
- 920/25 M83
- 920/42 M83
- 920/55 M83
- 920A M83
- 1150BM M136
- 1166BM M136
- 1084BM M136
- 1032 M145
- 1034 M145
- 1036 M145
- 1038 M145
- 882P
- 892/0



5904VG/2M 1.455,00 059041198

Assortimento consigliato in abbinamento con C23ST - C24S - C24SA - C24SA-XL - C24SL - C24SL/CAB - C37
C39 - C39T - C39SM - C39MD - C55 - C59 - C28

5904VG/2T

assortimento di 99 utensili in termoformato rigido in ABS

Autoriparazione



T05 T06 T80



T153 T138 T145 T234



T208 T33 T52 T55

14,5 kg

N. pezzi/Descrizione	Beta N.	TR	N. pezzi/Descrizione	Beta N.	TR
16 chiavi combinate 6÷21 mm	42NEW	T05	1 pinze becchi piegati per anelli elastici, per fori \odot 170 mm	1034	T145
5 chiavi combinate 22 - 24 - 27 - 30 - 32 mm	42NEW	T06	1 pinze becchi piegati per anelli elastici, per alberi \bullet 175 mm	1038	T145
19 chiavi a bussola esagonali 1/2"	920A	T80	2 scalpelli piatti nervati 100 - 200 mm	35	T234
\odot 10÷24 - 26 - 27 - 30 - 32 mm			1 martello tipo tedesco 300 g	1370	T234
5 chiavi a bussola maschio esagonale 1/2"	920ME	T80	1 mazzuola con battenti in materiale plastico \varnothing 35 mm	1390	T234
\odot 5 - 6 - 8 - 10 - 12 mm			4 giravite lama piatta \bullet 3x75 - 4x100 - 5,5x150 - 6,5x150 mm	1260	T208
1 prolunga - 1/2" 125 mm	920/21	T80	3 giravite per viti con impronta a croce Phillips®	1262	T208
1 prolunga - 1/2" 255 mm	920/22	T80	\oplus PH0x60 - PH1x80 - PH2x100 mm		
1 snodo 1/2"	920/25	T80	8 chiavi a forchetta 6x7 - 8x9 - 10x11 - 12x13 - 14x15 - 16x17 - 18x19 - 20x22 mm	55	T33
1 quadro maschio 1/2" con spina scorrevole	920/42	T80	9 chiavi maschio esagonale piegate	96/SC9	T33
1 cricchetto reversibile 1/2" \oplus	920/55	T80	\odot 1,5 - 2 - 2,5 - 3 - 4 - 5 - 6 - 8 - 10 mm		
1 pinze regolabili cerniera chiusa 250 mm	1048	T153	6 chiavi maschio esagonale con impugnatura	96T	T52
1 pinza autobloccante 240 mm	1052	T153	\odot 2 - 2,5 - 3 - 4 - 5 - 6 mm		
1 tronchesi a grande effetto taglienti diagonali ∇ 160 mm	1084	T138	6 chiavi maschio con impugnatura per viti con impronta Torx® \oplus	97TTX	T55
1 pinza a becchi mezzotondi diritti \bullet 160 mm	1166	T138	T10 - T15 - T20 - T25 - T27 - T30		
1 pinza universale \equiv 180 mm	1150	T138			
1 pinze becchi dritti per anelli elastici, per fori \odot 180 mm	1032	T145			
1 pinze becchi dritti per anelli elastici, per alberi \bullet 175 mm	1036	T145			



5904VG/2T 1.245,00 059041191

Assortimento consigliato in abbinamento con C23ST - C24S - C24SA - C24SA-XL - C24SL - C24SL/CAB - C28 C37 - C39 - C39SM - C39MD - C39T - C55 - C59

5904VG/3

assortimento di 132 utensili

Autoriparazione



20,7 kg

N. pezzi/Descrizione

6	cacciaspina Ø2=8 mm
1	bulino Ø5 mm
1	scalpelli piatti nervati 200 mm
17	chiavi combinate 6÷22 mm
8	chiavi a forchetta 6x7 - 8x9 - 10x11 - 12x13 - 14x15 - 16x17 - 18x19 - 20x22 mm
9	chiavi maschio esagonale piegate Ø 1,5 - 2 - 2,5 - 3 - 4 - 5 - 6 - 8 - 10 mm
11	chiavi maschio esagonale con impugnatura Ø 2÷10 mm
13	chiavi maschio piegate per viti con impronta Torx® T6÷T50
1	chiave regolabile a rullino 300 mm
13	chiavi a bussola esagonali 1/2" con guida Ø 10÷22 mm
1	prolunga - 1/2" 125 mm
1	prolunga - 1/2" 255 mm
1	snodo 1/2"
1	quadro maschio 1/2" con spina scorrevole
1	cricchetto con quadro scorrevole 1/2" Ø
6	chiavi a T con bussola snodata Ø 8 - 10 - 12 - 13 - 17 - 19 mm
1	leva piatta curva con impugnatura 450 mm
2	pinze becchi dritti per anelli elastici, per fori Ø 180 - 225 mm
2	pinze becchi piegati per anelli elastici, per fori Ø 170 - 210 mm
2	pinze becchi dritti per anelli elastici, per alberi Ø 175 - 225 mm
2	pinze becchi piegati per anelli elastici, per alberi Ø 175 - 220 mm
1	pinze regolabili cerniera chiusa 250 mm
1	pinza autobloccante 240 mm
1	tronchesi a grande effetto, a taglienti diagonali, finitura industriale 200 mm
1	tronchesi doppia leva taglio frontale 200 mm

Beta N.

31/B6
32
35
42NEW
55
96N/SC9
96T/SP11
97TX/B13
111
920A/SB13
920/21
920/22
920/25
920/42
920/50
952
965
1032
1034
1036
1038
1048
1057A
1084GBM
1092V

N. pezzi/Descrizione

1	cesoia a lame larghe diritte 250 mm
1	forbici per elettricisti lame diritte
1	pinze universali a grande effetto, finitura industriale 180 mm
4	giravite lama piatta Ø 3x75 - 4x100 - 5,5x125 - 6,5x150 mm
1	giravite nano lama piatta Ø 6,5x30 mm
2	giravite lama piatta con esagono di manovra Ø 8x175 - 10x200 mm
3	giravite per viti con impronta a croce Phillips® PH0x100 - PH1x120 - PH2x100 mm
1	giraviti nano Phillips® PH2x30 mm
1	giravite Phillips® con esagono di manovra PH3x175mm
1	giravite lungo Phillips® PH2x400 mm
1	giravite lungo lama parallela Ø 6,5x400 mm
1	martello tipo tedesco 500 g
1	mazzuola con battenti in materiale plastico Ø 45 mm
1	chiave regolabile a nastro per filtri olio
1	spessimetro
5	serie di 5 lime 200 mm
1	seghetto
1	oliatore in metallo a pressione 200 cc

Beta N.

1112
1128BMX
1150GBM
1260
1260N
1260E
1262
1262N
1262E
1262L
1264L
1370
1390
1491
1708/20
1719BMA...S5
1726BM
1751



5904VG/3 1.895,00 059041062

Assortimento consigliato in abbinamento con C24S - C24SA - C24SA-XL - C24SL - C24SL/CAB - C37 - C39 da 7 - 8 cassette - C55 - C59

5904VG/3T

assortimento di 102 utensili in termoformato rigido in ABS

Autoriparazione



T199 T202 T83



T145 T153 T137 T234



T52 T33 T05 T06



T63 VP5

N. pezzi/Descrizione

Beta N. TR

N. pezzi/Descrizione

Beta N. TR

21	chiavi combinate 6-7-8-9-10-11-12-13-14-15-16-17-18-19-20-21-22-24-27-30-32 mm	42NEW	T05-T06
8	chiavi a forchetta 6x7-8x9-10x11-12x13-14x15-16x17-18x19-20x22 mm	55	T33
9	chiavi maschio esagonale piegate \varnothing 1,5+10 mm	96/SC9	T33
6	chiavi maschio esagonale con impugnatura \varnothing 2-2,5-3-4-5-6 mm	96T	T52
8	chiavi a T con bussola snodata \varnothing 7-8-10-12-13-14-17-19 mm	952	T63
19	chiavi a bussola esagonali 1/2" \varnothing 10-11-12-13-14-15-16-17-18-19-20-21-22-23-24-26-27-30-32 mm	920A	T83
1	prolunga - 1/2" 125 mm	920/21	T83
1	prolunga - 1/2" 255 mm	920/22	T83
1	snodo 1/2"	920/25	T83
1	quadro maschio 1/2" con spina scorrevole 305 mm	920/42	T83
1	cricchetto reversibile 1/2" \otimes	920/55	T83
1	tronchesi a grande effetto taglienti diagonali ∇ 160 mm	1084BM	T137
1	pinza universale \equiv 180 mm	1150BM	T137
1	pinza a becchi mezzotondi dritti \bullet 160 mm	1166BM	T137
1	pinze becchi dritti per anelli elastici, per fori \varnothing 180 mm	1032	T145

1	pinze becchi piegati per anelli elastici, per fori \varnothing 170 mm	1034	T145
1	pinze becchi dritti per anelli elastici, per alberi \bullet 175 mm	1036	T145
1	pinze becchi piegati per anelli elastici, per alberi \bullet 175 mm	1038	T145
1	pinza autobloccante 240 mm	1052	T153
1	pinze regolabili cerniera chiusa 250 mm	1048	T153
7	giravite lama piatta \bullet 2,5x50 - 3x75 - 3,5x100 - 4x125 - 5,5x100 - 5,5x150 - 6,5x150 mm	1260	T199
6	giravite per viti con impronta a croce Phillips® \oplus PH0x60 - PH0x100 - PH1x80 - PH1x120 - PH2x100 - PH2x150 mm	1262	T202
2	scalpelli piatti nervati 100-200 mm	35	T234
1	martello tipo tedesco 300 g	1370	T234
1	mazzuola con battenti in materiale plastico \varnothing 35 mm	1390	T234
1	termoformato vuoto	VP5	



5904VG/3T 1.440,00 059041510

Assortimento consigliato in abbinamento con C23ST - C24S - C24SA - C24SA-XL - C24SL - C24SL/CAB - C28 - C37 - C39 - C39MD - C39SM - C39T - C55 - C59

5904VG/5T

assortimento di 153 utensili in termoformato rigido in ABS

Autoriparazione



T80 T05 T06



T63 VP6



T145 T170 T176 T52



T33 T171 T172 T173



T234 T137 T112 T153

25 kg

N. pezzi/Descrizione

5	chiavi a bussola maschio esagonale 1/2" ⌀ 5 - 6 - 8 - 10 - 12 mm	920ME	T80
1	prolunga - 1/2" 125 mm	920/21	T80
1	prolunga - 1/2" 255 mm	920/22	T80
1	snodo 1/2"	920/25	T80
1	quadro maschio 1/2" con spina scorrevole	920/42	T80
1	cricchetto reversibile 1/2" ⌀	920/55	T80
19	chiavi a bussola esagonali 1/2" ⌀ 10+24 - 26 - 27 - 30 - 32 mm	920A	T80
16	chiavi combinate 6+21 mm	42NEW	T05
5	chiavi combinate 22 - 24 - 27 - 30 - 32 mm	42NEW	T06
8	chiavi a T con bussola snodata ⌀ 7 - 8 - 10 - 12 - 13 - 14 - 17 - 19 mm termoformato vuoto	952	T63
1	pinze becchi dritti per anelli elastici, per fori ⌀ 180 mm	VP6	VP6
1	pinze becchi piegati per anelli elastici, per fori ⌀ 170 mm	1032	T145
1	pinze becchi dritti per anelli elastici, per alberi ⌀ 175 mm	1034	T145
1	pinze becchi piegati per anelli elastici, per alberi ⌀ 175 mm	1036	T145
1	pinze becchi piegati per anelli elastici, per alberi ⌀ 175 mm	1038	T145
7	giravite lama piatta ⌀ 2,5x50 - 3x75 - 3,5x100 - 4x125 - 5,5x100 - 5,5x150 - 6,5x150 mm	1290	T170
5	chiavi maschio con impugnatura per viti con impronta Torx® ⌀ T25 - T27 - T30 - T40 - T45	1297TX	T176
6	chiavi maschio esagonale con impugnatura ⌀ 2 - 2,5 - 3 - 4 - 5 - 6 mm	96T	T52
8	chiavi a forchetta 6x7 - 8x9 - 10x11 - 12x13 - 14x15 - 16x17 - 18x19 - 20x22 mm	55	T33
9	chiavi maschio esagonale piegate ⌀ 1,5 - 2 - 2,5 - 3 - 4 - 5 - 6 - 8 - 10 mm	96N/SC9	T33
3	giravite lama piatta ⌀ 8x150 - 8x200 - 10x200 mm	1290	T171

Beta N. TR

N. pezzi/Descrizione

2	giravite nano lama piatta ⌀ 4x30 - 6,5x30 mm	1290N	T171
6	giravite Phillips® ⌀ PH0x60 - PH0x100 - PH1x80 - PH1x120 - PH2x100 - PH2x150 mm	1292	T172
2	giravite Phillips® ⌀ PH3x150 - PH4x200 mm	1292	T173
2	giravite nano Phillips® ⌀ PH1x30 - PH2x30 mm	1292N	T173
2	scalpelli piatti nervati 100 - 200 mm	35	T234
1	martello tipo tedesco 300 g	1370	T234
1	mazzuola con battenti in materiale plastico Ø 35 mm	1390	T234
1	pinza universale = 180 mm	1150BM	T137
1	pinza a becchi mezzotondi dritti ⌀ 160 mm	1166BM	T137
1	tronchesi a grande effetto taglienti diagonali ⚡ 160 mm	1084BM	T137
6	inserti per avvitatori per viti con impronta Torx® ⌀ T6+T15	861TX	T112
8	inserti per avvitatori per viti con impronta Torx® ⌀ T20+T55	866TX	T112
1	bussola portainseri	895/1	T112
1	bussola portainseri	895/6	T112
6	chiavi a bussola 1/4" per viti con teste a profilo Torx® ⌀ E4+E10	900FTX	T112
7	chiavi a bussola 1/2" per viti con teste a profilo Torx® ⌀ E12+E24	920FTX	T112
3	chiavi a bussola maschio per viti con impronta Torx® 1/2" ⌀ T55L - T60 - T70L	920TX	T112
1	pinze regolabili cerniera chiusa 250 mm	1048	T153
1	pinza autobloccante 240 mm	1052	T153
1	termoformato vuoto	VP6	

Beta N. TR

5904VG/5T 1.980,00 059041196

Assortimento consigliato in abbinamento con C23ST - C24S da 7-8 cassette - C24SA da 7-8 cassette - C24SA-XL da 7-8 cassette - C24SL - C24SL/CAB C28 - C37 da 7-8 cassette - C39 da 7-8 cassette - C39MD - C39SM - C55 - C59

5905VG/1

assortimento di 94 utensili per carrozzieri

Autoriparazione



20 kg

N. pezzi/Descrizione

1	punzoni Ø 4 mm
6	cacciaspina Ø 2 - 3 - 4 - 5 - 6 - 8 mm
1	bulino Ø 4 mm
1	scalpelli piatti 150 mm
1	ugnetti 150 mm
17	chiavi combinate 6÷22 mm
10	chiavi maschio esagonale piegate Ø 1,5÷12 mm
1	chiave regolabile a rullino 300 mm
12	chiavi a bussola con impugnatura, tipo lungo Ø 4÷14 mm
1	leva piatta curva con impugnatura 450 mm
1	pinze regolabili cerniera chiusa 250 mm
1	pinza autobloccante 240 mm
1	pinza autobloccante ganasce alluminio 280 mm
1	tronchesi a grande effetto, a taglienti diagonali, finitura industriale 160 mm
1	tenaglia per cementisti 250 mm
1	cesoia a doppia leva dritta
1	forbici per elettricisti lame dritte
1	pinze universali a grande effetto, finitura industriale 180 mm
1	giravite Dzus®
4	giravite lama piatta 3x75 - 4x100 - 5,5x150 - 6,5x150 mm
1	giravite nano lama piatta 4x30 mm
2	giravite lama piatta con esagono di manovra 10x175 - 12x200 mm

Beta N.

30
31/B6
32
34
36
42NEW
96/B10
111N
943BX
965
1048
1052
1060AL
1084GBM
1098PL
1122
1128BMX
1150GBM
1201E/DZ
1260
1260N
1260E

N. pezzi/Descrizione

3	giravite per viti con impronta a croce Phillips®
	➤ PH0x60 - PH1x80 - PH2x100 mm
1	giravite nano Phillips® ➤ PH1x30 mm
1	giravite Phillips® con esagono di manovra ➤ PH3x175 mm
7	chiave maschio per viti con impronta Torx®
	➤ T6 - T8 - T10 - T15 - T20 - T25 - T30
1	tasso a virgola 1350 g
1	tasso curvo
1	tasso a tacco bombato
1	tasso a rotaia
1	tasso a tampone
1	leva a cazzuola
1	leva a cucchiaio pesante
1	leva a gomito e piana
1	lima e portalima
1	scalpello extrapiatto con paramano
1	martello con testa tonda e penna
1	martelli con teste piane tonda e quadra manico in legno Ø 32 mm
1	martello tipo tedesco 300 g
1	mazzuola con battenti in materiale plastico Ø 35 mm
1	flessometro 5 m

Beta N.

1262
1262N
1262E
1267TX
1303
1305
1306
1310
1313
1326
1327
1330
1338A
1342PM
1345
1357Z/32
1370
1390
1692



5905VG/1 1.740,00 059051058

Assortimento consigliato in abbinamento con C25

Autoriparazione



19,5 kg

N. pezzi/Descrizione

- 6 2 punzoni, 1 bulino, 3 scalpelli con supporto
- 13 chiavi combinate 6+14 - 17 - 19 - 22 - 24 mm
- 13 chiavi a forchetta 6x7 - 8x9 - 10x11 - 12x13 - 14x15 - 16x17 - 18x19 - 20x22 - 21x23 - 24x26 - 25x28 - 27x29 - 30x32 mm
- 3 chiavi poligonali doppie starter 11x13 - 14x17 - 19x22 mm
- 10 chiavi maschio esagonale piegate \odot 1,5+12 mm
- 6 chiavi maschio con impugnatura per viti con impronta Torx® \odot T10 - T15 - T20 - T25 - T30 - T40
- 2 chiavi a bussola Macchina 1/2" \odot 17 - 19 mm
- 20 chiavi a bussola esagonali 1/2" \odot 10+24 - 26 - 27 - 28 - 30 - 32 mm
- 1 prolunga - 1/2" 125 mm
- 1 prolunga - 1/2" 255 mm
- 1 snodo 1/2"
- 1 quadro maschio 1/2" con spina scorrevole
- 1 cricchetto reversibile 1/2" \odot
- 8 chiavi a T con bussola snodata \odot 7 - 8 - 10 - 11 - 13 - 14 - 17 - 19 mm
- 1 chiavi a T con bussola snodata per candele
- 1 chiave a croce \odot 17x19x22x \blacksquare 1/2"
- 1 pinze becchi dritti per anelli elastici, per fori \odot 180 mm
- 1 pinze becchi piegati per anelli elastici, per fori \odot 170 mm
- 1 pinze becchi dritti per anelli elastici, per alberi \bullet 175 mm
- 1 pinze becchi piegati per anelli elastici, per alberi \bullet 175 mm

Beta N.

- 38/B6
- 42NEW
- 55
- 83
- 96N/B10
- 97TTX
- 720
- 920A
- 920/21
- 920/22
- 920/25
- 920/42
- 920/55
- 952
- 959
- 979
- 1032
- 1034
- 1036
- 1038

N. pezzi/Descrizione

- 1 pinze regolabili cerniera chiusa 250 mm 1048
- 1 pinza autobloccante 240 mm 1052
- 1 tronchesi a grande effetto, a taglienti diagonali, finitura industriale ∇ 160 mm 1084GBM
- 1 cesoia a doppia leva dritta 250 mm 1122
- 1 forbici per elettricisti lame dritte 1128BMX
- 1 pinze universali a grande effetto, finitura industriale \equiv 180 mm 1150GBM
- 1 pinze a becchi mezzotondi lunghissimi, dritti zigrinati, impugnatura bimatereale, finitura industriale \bullet 160 mm 1166GBM
- 8 giravite lama piatta \bullet 2,5x50 - 3x75 - 3,5x100 - 4x125 - 5,5x125 - 6,5x150 - 8x200 - 10x200 mm 1260
- 2 giravite lama piatta con esagono di manovra \bullet 10x200 - 12x250 mm 1260E
- 1 giravite nano lama piatta \bullet 6,5x30 mm 1260N
- 4 giravite per viti con impronta a croce Phillips® \oplus PH0x60 - PH1x80 - PH2x100 - PH3x150 mm 1262
- 1 martello tipo tedesco 400 g 1370
- 1 mazzuola con battenti in materiale plastico \varnothing 35 mm 1390
- 1 chiave regolabile a nastro per filtri olio 1491
- 1 provatensione 3+48 V 1498



5905VG/2 1.635,00 059051044

Assortimento consigliato in abbinamento con C25

Autoriparazione



N. pezzi/Descrizione

N. pezzi/Descrizione	Beta N.	TR
16 chiavi combinate 6+21 mm	42NEW	T05
5 chiavi combinate 22 - 24 - 27 - 30 - 32 mm	42NEW	T06
5 cacciaspina Ø 2 - 3 - 4 - 5 - 6 mm	31	T31
1 bulino Ø 4 mm	32	T31
12 chiavi a forchetta 6x7 - 8x9 - 10x11 - 12x13 - 14x15 - 16x17 - 18x19 - 20x22 - 21x23 - 24x26 - 27x29 - 30x32 mm	55	T31
9 chiavi maschio esagonale piegate Ø 1,5 - 2 - 2,5 - 3 - 4 - 5 - 6 - 8 - 10 mm	96N/SC9	T31
5 chiavi a bussola maschio esagonale 1/2" Ø 5 - 6 - 8 - 10 - 12 mm	920ME	T80
1 prolunga - 1/2" 125 mm	920/21	T80
1 prolunga - 1/2" 255 mm	920/22	T80
1 snodo 1/2"	920/25	T80
1 quadro maschio 1/2" con spina scorrevole	920/42	T80
1 cricchetto reversibile 1/2" @	920/55	T80
19 chiavi a bussola esagonali 1/2" Ø 10+24 - 26 - 27 - 30 - 32 mm	920A	T80
1 pinze becchi dritti per anelli elastici, per fori Ø 180 mm	1032	T145
1 pinze becchi piegati per anelli elastici, per fori Ø 170 mm	1034	T145
1 pinze becchi dritti per anelli elastici, per alberi ● 175 mm	1036	T145
1 pinze becchi piegati per anelli elastici, per alberi ● 175 mm	1038	T145
1 pinze becchi dritti per anelli elastici, per fori Ø 140 mm	1032	T146
1 pinze becchi dritti per anelli elastici, per fori Ø 225 mm	1032	T146
1 pinze becchi dritti per anelli elastici, per alberi ● 140 mm	1036	T146
1 pinze becchi dritti per anelli elastici, per alberi ● 225 mm	1036	T146
9 giravite lama piatta ● 3x75 - 3x100 - 4x100 - 4x150 - 5,5x100 - 5,5x150 - 6,5x150 - 8x150 - 10x200 mm	1260	T167
2 giravite nano lama piatta ● 4x30 - 6,5x30 mm	1260N	T167
7 giravite per viti con impronta a croce Phillips* ● PH0x60 - PH0x100 - PH1x80 - PH1x120 - PH2x100 - PH2x150 - PH3x150 mm	1262	T168
2 giraviti nano Phillips* ● PH1x30 - PH2x30 mm	1262N	T168
8 chiavi a T con bussola snodata Ø 7 - 8 - 10 - 12 - 13 - 14 - 17 - 19 mm	952	T63
2 giravite lungo Phillips* ● PH1x400 - PH2x400 mm	1262L	T209
3 giravite lungo lama parallela ● 3x300 - 4x400 - 5x400 mm	1264L	T209
6 chiavi maschio con impugnatura per viti con impronta Torx* ● T10-T15-T20-T25-T27-T30	97TTX	T55
13 chiavi a bussola Macchina 1/2" Ø 10-11-12-13-14-16-17-18-19-21-22-23-24 mm	720	T110
1 prolunga Macchina con attacchi quadri maschio e femmina 1/2" 125 mm	720/21	T110
5 chiavi a bussola maschio esagonale 1/2" Ø 5L - 6L - 7L - 8L - 10L	920PE	T113

N. pezzi/Descrizione

N. pezzi/Descrizione	Beta N.	TR
4 chiavi a bussola maschio per viti con impronta Torx* 1/2" Ø T40L - T45L - T55L - T70L	920TX	T113
3 chiavi a bussola maschio a profilo XZN* Ø M6L - M8L - M12L	920XZN	T113
5 lime a taglio mezzodolce 200 mm	1719BMA8/S5	T236
1 chiave regolabile a nastro per filtri olio 110 mm	1491	T264
1 chiave a bussola quadrata per tappi olio motore ■ 10 mm	1494	T264
7 chiavi a bussola maschio esagonale per tappi olio motore Ø 8-9-10-11-12-14-17 mm	1494E	T264
4 chiavi a bussola maschio quadrato per tappi olio motore Ø 8-9,5-12-13 mm	1494Q	T264
1 chiave a bussola maschio triangolare per tappi olio motore Δ	1494T	T264
1 chiave a bussola maschio con profilo XZN* per tappi olio motore Ø	1494XZN	T264
1 chiavi per tappi olio motore	1496/C	T264
2 scalpelli piatti nervati 100 - 200 mm	35	T234
1 martello tipo tedesco 300 g	1370	T234
1 mazzuola con battenti in materiale plastico Ø 35 mm	1390	T234
1 pinze regolabili cerniera chiusa 250 mm	1048	T153
1 pinza autobloccante 240 mm	1052	T153
1 pinza universale ■ 180 mm	1150	T138
1 pinza a becchi mezzotondi dritti ● 160 mm	1166	T138
1 tronchesi a grande effetto taglienti diagonali ✂ 160 mm	1084	T138
11 chiavi a bussola esagonali 3/4" Ø 22-24-27-30-32-34-36-38-41-46-50 mm	928A	T105
1 prolunga - 3/4" 200 mm	928/21	T106
1 prolunga - 3/4" 380 mm	928/22	T106
1 quadro maschio 3/4" con spina scorrevole 450 mm	928/42	T106
1 cricchetto reversibile 3/4" @	928/55	T106
1 termoformato vuoto	VP6	VP6
4 chiavi maschio esagonale piegate Ø 13-14-17-19 mm	96N	
1 chiave regolabile a rullino 300 mm	111	
1 leva piatta curva con impugnatura	965	
1 cesoia a lame larghe diritte 250 mm	1112	
1 forbici per elettricisti lame diritte	1128BMX	
1 martello tipo tedesco 1000 g	1370	
1 spessimetro	1708/20	
1 magnete telescopico punta flessibile	1712	
1 specchio telescopico	1715	
1 rascchetto a tre taglienti 200 mm	1717B	
1 seghetto 440 mm	1726	
1 spazzola fili d'acciaio	1737NX	
1 oliatore in metallo a pressione 200 cl	1751	
1 cutter con lama a settori	1771	



5908VG/2T 3.310,00 059081017

Assortimento consigliato in abbinamento con C28

Autoriparazione



N. pezzi/Descrizione

N. pezzi/Descrizione	Beta N.	TR
16 chiavi combinate 6÷21 mm	42NEW	T05
5 chiavi combinate 22 - 24 - 27 - 30 - 32 mm	42NEW	T06
6 chiavi a bussola poligonale snodate doppie 8x9 - 10x11 - 12x13 - 14x15 - 16x17 - 18x19 mm	80	T79
1 chiave regolabile a nastro per filtri olio 110 mm	1491	T264
1 chiave a bussola quadrata per tappi olio motore 10 mm	1494	T264
7 chiavi a bussola maschio esagonale per tappi olio motore 8-9-10-11-12-14-17 mm	1494E	T264
4 chiavi a bussola maschio quadrato per tappi olio motore 8-9,5-12-13 mm	1494Q	T264
1 chiave a bussola maschio triangolare per tappi olio motore Δ	1494T	T264
1 chiave a bussola maschio con profilo XZN® per tappi olio motore ○	1494XZN	T264
1 chiavi per tappi olio motore	1496/C	T264
5 chiavi a bussola maschio esagonale 1/2" ○ 5 - 6 - 8 - 10 - 12 mm	920ME	T80
1 prolunga - 1/2" 125 mm	920/21	T80
1 prolunga - 1/2" 255 mm	920/22	T80
1 snodo 1/2"	920/25	T80
1 quadro maschio 1/2" con spina scorrevole	920/42	T80
1 cricchetto reversibile 1/2" ◎	920/55	T80
19 chiavi a bussola esagonali 1/2" ○ 10÷24 - 26 - 27 - 30 - 32 mm	920A	T80
1 pinze becchi dritti per anelli elastici, per fori ○ 180 mm	1032	T145
1 pinze becchi piegati per anelli elastici, per fori ○ 170 mm	1034	T145
1 pinze becchi dritti per anelli elastici, per alberi ● 175 mm	1036	T145
1 pinze becchi piegati per anelli elastici, per alberi ● 175 mm	1038	T145
1 pinze becchi dritti per anelli elastici, per fori ○ 140 mm	1032	T146
1 pinze becchi piegati per anelli elastici, per fori ○ 225 mm	1034	T146
1 pinze becchi dritti per anelli elastici, per alberi ● 140 mm	1036	T146
1 pinze becchi piegati per anelli elastici, per alberi ● 225 mm	1038	T146
6 chiavi maschio con impugnatura per viti con impronta Torx® ○ T10-T15-T20-T25-T27-T30	97TTX	T55
12 chiavi combinate a cricchetto snodate 8 - 9 - 10 - 11 - 12 - 13 - 14 - 15 - 16 - 17 - 18 - 19 mm	142SN	T46
1 pinza universale 180 mm	1150BM	T137

Beta N.

TR

N. pezzi/Descrizione

N. pezzi/Descrizione	Beta N.	TR
1 pinza a becchi mezzotondi dritti ● 160 mm	1166BM	T137
1 tronchesi a grande effetto taglienti diagonali ≤ 160 mm	1084BM	T137
1 pinza regolabile a pulsante 240 mm	1047	T151
1 pinza autobloccante 240 mm	1057A	T151
8 chiavi a T con bussola snodata ○ 7 - 8 - 10 - 12 - 13 - 14 - 17 - 19 mm	952	T63
9 giravite lama piatta ● 3x75 - 3,5x100 - 4x100 - 4x150 - 5,5x100 - 5,5x150 - 6,5x150 - 8x150 - 10x200 mm	1260	T167
2 giravite nano lama piatta ● 4x30 - 6,5x30 mm	1260N	T167
6 cacciapinna	31/B6	
7 giravite per viti con impronta a croce Phillips® ● PH0x60 - PH0x100 - PH1x80 - PH1x120 - PH2x100 - PH2x150 - PH3x150 mm	1262	T168
2 giraviti nano Phillips® ● PH1x30 - PH2x30 mm	1262N	T168
1 chiave regolabile a rullino 250 mm	111	T59
1 quadro maschio a T snodato 1/2"	920/40	T59
6 chiavi a T maschio esagonale ○ 2,5-3-4-5-6-8 mm	951	T59
4 chiavi a T con maschio esagonale snodato ○ 4-5-6-8 mm	953	T59
2 martello tipo tedesco 300-500 g	1370	T59
2 giravite lungo Phillips® ● PH1x400 - PH2x400 mm	1262L	T209
3 giravite lungo lama parallela ● 3x300 - 4x400 - 5x400 mm	1264L	T209
9 chiavi maschio esagonale piegate con estremità sferica ○	96BPC/SC9	
1 chiavi dinamometriche a scatto ◎ 8 ÷ 60 Nm	666N/5	
1 chiavi dinamometriche a scatto ◎ 60 ÷ 330 Nm	666N/30	
12 chiavi a bussola Macchina	720/C12	
1 raccordo quadro maschio 1/2" e femmina 3/8"	910/16	
1 assortimento di 12 chiavi a bussola e 5 accessori 3/4"	928A/C12	
3 leva con testa snodata piatta curva	966/C3	
1 mazzuola antirimbalo Ø 50 mm	1392	
1 avvitatore reversibile in materiale composito 12V	1927P	

Beta N.

TR

5935VG/1MB

assortimento di 98 utensili per cassettera C35, in vassoio morbido in EVA

Autoriparazione



MB12



MB39



MB46

N. pezzi/Descrizione

Beta N. TR

N. pezzi/Descrizione

Beta N. TR

- 21 chiavi combinate 6-7-8-9-10-11-12-13-14-15-16-17-18-19-20-21-22-24-27-30-32 mm
- 8 chiavi a forchetta 6x7-8x9-10x11-12x13-14x15-16x17-18x19-20x22 mm
- 1 pinze regolabili cerniera chiusa 250 mm
- 4 giravite lama piatta ● 3x75-4x100-5x125-6,5x150 mm
- 3 giravite per viti con impronta a croce Phillips®
● PH0x60-PH1x80--PH2x100 mm
- 6 chiave maschio per viti con impronta Torx®
● T8-T10-T15-T20-T25-T30
- 9 chiavi maschio esagonale piegate con estremità sferica ○
- 6 chiavi maschio esagonale con impugnatura ○ 2-2,5-3-4-5-6
- 1 pinza autobloccante 240 mm
- 19 chiavi a bussola esagonali 1/2" ○ 10-11-12-13-14-15-16-17-18-19-20-21-22-23-24-26-27-30-32 mm
- 1 prolunga - 1/2" 125 mm
- 1 prolunga - 1/2" 250 mm

- 42NEW **MB12**
- 55 **MB12**
- 1048 **MB12**
- 1260 **MB46**
- 1262 **MB46**
- 1267TX **MB46**
- 96BPC/SC9 **MB46**
- 96T **MB46**
- 1052 **MB46**
- 920A **MB39**
- 920/21 **MB39**
- 920/22 **MB39**

- 1 snodo 1/2"
- 1 quadro maschio 1/2" con spina scorrevole
- 1 cricchetto reversibile 1/2" ⊕
- 5 chiavi a bussola maschio esagonale 1/2" ○ 5-6-8-10-12 mm
- 1 pinze becchi dritti per anelli elastici, per fori ○ 180 mm
- 1 pinze becchi piegati per anelli elastici, per fori ○ 170 mm
- 1 pinze becchi dritti per anelli elastici, per alberi ● 175 mm
- 1 pinze becchi piegati per anelli elastici, per alberi ● 175 mm
- 1 scalpelli piatti nervati 200 mm
- 1 tronchesi a grande effetto taglienti diagonali < 160 mm
- 1 pinza universale = 180 mm
- 1 pinza a becchi mezzotondi dritti ● 160 mm
- 1 martello tipo tedesco 500 g
- 1 mazzuola con battenti in materiale plastico 35 mm

- 920/25 **MB39**
- 920/42 **MB39**
- 920/55 **MB39**
- 920PE **MB39**
- 1032 **MB39**
- 1034 **MB39**
- 1036 **MB39**
- 1038 **MB39**
- 35 **MB39**
- 1084BM **MB39**
- 1150BM **MB39**
- 1166BM **MB39**
- 1370 **MB39**
- 1390 **MB39**



5935VG/1MB 1.315,00 059351321

Assortimento consigliato in abbinamento con C35

Motoriparazione

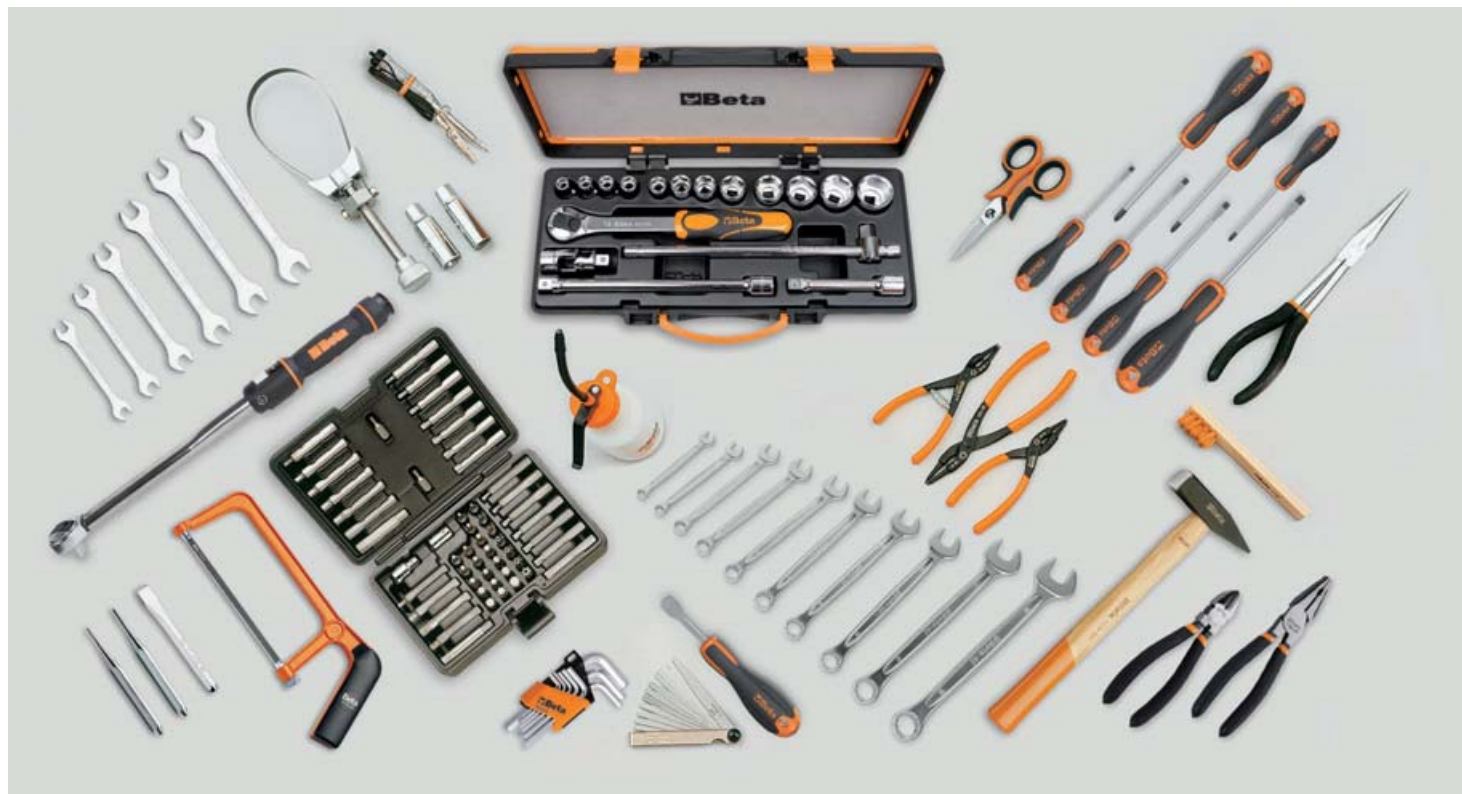

N. pezzi/Descrizione

1	punzoni Ø 2 mm	30
1	bulino Ø 4 mm	32
1	scalpelli piatti 125 mm	34
10	chiavi combinate 6 - 7 - 8 - 10 - 11 - 12 - 13 - 14 - 17 - 19 mm	42NEW
6	chiavi a forchetta 6x7 - 8x9 - 10x11 - 12x13 - 14x15 - 16x17 mm	55
9	chiavi maschio esagonale piegate Ø 1,5 - 2 - 2,5 - 3 - 4 - 5 - 6 - 8 - 10 mm	96/SC9
1	chiavi dinamometriche a scatto @ 3/8", 8+60 Nm	666N/5
54	assortimento di 52 inserti con attacco esagonale 10 mm e 2 accessori	867/C52
17	assortimento di 12 chiavi a bussola e 5 accessori	920A/C12X
1	raccordo quadro maschio 1/2" e femmina 3/8"	910/16
2	chiavi a bussola per candele Ø 14 - 16 mm	956C
1	pinza a becchi mezzotondi lunghissimi Ø 283 mm	1009L/A
2	pinze becchi dritti per anelli elastici, per fori Ø 140 - 180 mm	1032

Beta N.

N. pezzi/Descrizione

1	pinze becchi dritti per anelli elastici, per alberi Ø 140x1,3 mm	1036
1	tronchesi a taglienti diagonali, finitura industriale 160 mm	1082G
1	forbici per elettricisti lame dritte	1128BM
1	pinze universali a grande effetto, finitura industriale 180 mm	1150G
1	giravite Dzus®	1201E/DZ
4	giravite lama piatta Ø 3x75 - 4x100 - 5,5x100 - 6,5x150 mm	1201E
3	giravite Phillips® PH0x60 - PH1x80 - PH2x100 mm	1202E
1	giravite provacircuito	1254
1	martello tipo tedesco 300 g	1370
1	chiave regolabile a nastro per filtri olio	1491
1	spessimetro	1708/13
1	miniseghetto	1725CR
1	spazzola fili d'ottone	1737
1	oliatore in plastica a pressione 250 cc	1754

Beta N.

1036
1082G
1128BM
1150G
1201E/DZ
1201E
1202E
1254
1370
1491
1708/13
1725CR
1737
1754



5940SBK 1.036,00 059401082

Assortimento consigliato in abbinamento con C41H - C41S - C42H - C42S

5941VU/M

assortimento di 64 utensili per trolley C41H, in vassoio morbido in EVA

Universali



N. pezzi/Descrizione	Beta N.	TR	N. pezzi/Descrizione	Beta N.	TR
16 chiavi combinate 6-7-8-9-10-11-12-13-14-15-16-17-18-19-21-22 mm	42NEW	MC12	1 tronchesi a taglienti diagonali, finitura industriale ∇ 160 mm	1082GBM	
9 chiavi maschio esagonale piegate \odot	96/SC9	MC12	1 forbici per elettricisti lame diritte 145 mm	1128BMX	
1 flessometro 5 m	1692/5	MC12	1 pinze universali a grande effetto, finitura industriale \equiv 180 mm	1150GBM	
19 chiavi a bussola esagonali 1/2" \odot 10-11-12-13-14-15-16-17-18-19-20-21-22-23-24-26-27-30-32 mm	920A	MC21	1 pinze a becchi mezzotondi lunghissimi, diritti zigrinati, impugnatura bimatereale, finitura industriale \bullet 160 mm	1166GBM	
1 snodo 1/2"	920/25	MC21	3 giravite lama piatta \bullet 3,5x100-5,5x125-6,5x150 mm	1260	
1 quadro maschio 1/2" con spina scorrevole	920/42	MC21	3 giravite per viti con impronta a croce Phillips®	1262	
1 cricchetto reversibile 1/2" \oplus	920/55	MC21	\oplus PH0-PH1-PH2		
2 prolunga angolare - 1/2" 125-250 mm	920AN	MC21	1 martello tipo tedesco 300 g	1370	
1 chiave regolabile a rullino 250 mm	111		1 cutter con lama a settori 18 mm	1771	
1 pinze regolabili cerniera chiusa 250 mm	1048				



5941VU/M 721,00 059411002

Assortimento consigliato in abbinamento con C41H

Universali



MM11



MM61



MM105



MM140



MM210

N. pezzi/Descrizione

- 21 chiavi combinate 6-7-8-9-10-11-12-13-14-15-16
17-18-19-20-21-22-24-27-30-32 mm
- 8 chiavi maschio esagonale con impugnatura \varnothing 2-2,5-3-4-5-6-7-8 mm
- 5 chiavi maschio con impugnatura per viti con impronta Torx®
 \varnothing T10-T15-T20-T25-T30
- 1 martello tipo tedesco 300 g
- 1 mazzuola con battenti in materiale plastico \varnothing 35
- 2 scalpelli piatti nervati 100-200 mm
- 5 lime a taglio mezzodolce 200 mm
- 9 chiavi maschio esagonale piegate con estremità sferica \varnothing 1,5-2-2,5-3-4-5-6-8-10 mm
- 1 bussola portainseri \square 1/4 - \square 1/4
- 1 bussola portainseri \square 1/4 - \square 3/8
- 1 bussola portainseri \square 5/16 - \square 1/2
- 13 chiavi a bussola esagonali 1/4" \varnothing 4-4,5-5-5,5-6-7-8-9-10-11-12-13-14 mm
- 9 chiavi a bussola a mano lunghe bocca esagonale \varnothing 5-6-7-8-9-10-11-12-13 mm
- 5 chiavi a bussola maschio esagonale 1/4" \varnothing 3-4-5-6-7 mm
- 4 chiavi a bussola a giravite per viti con intaglio \bullet 0,8x4-1x5,5x1,2x6,5-1,2x8 mm
- 4 chiavi a bussola a giravite per viti con impronta a croce Phillips®
 \bullet PH1-PH2-PH3-PH4
- 7 chiavi a bussola a giravite maschio per viti con impronta Torx®
 \varnothing T10-T15-T20-T25-T27-T30-T40
- 1 raccordo con attacco quadro \square 1/4 - \blacksquare 3/8
- 1 prolunga - 1/4" 50 mm
- 1 prolunga - 1/4" 100 mm
- 1 prolunga - 1/4" 150 mm
- 1 snodo 1/4"
- 1 quadro con impugnatura 1/4" 176 mm
- 1 quadro scorrevole 1/4" 115 mm
- 1 cricchetto reversibile 1/4" \varnothing 125 mm
- 17 chiavi a bussola esagonali 3/8" \varnothing 6-7-8-9-10-11-12-13-14-15-16-17-18-19-20-21-22 mm
- 1 raccordo con attacco quadro \square 3/8 - \blacksquare 1/4
- 1 raccordo quadro maschio 1/2" e femmina 3/8" \square 3/8 - \blacksquare 1/2
- 1 prolunga - 3/8" 125 mm
- 1 prolunga - 3/8" 250

Beta N.

TR

- 42NEW MM11
- 96T MM61
- 97TTX MM140
- 1370 MM61
- 1390 MM61
- 35 MM61
- 1719BMA8/S5 MM61
- 96BPC/SC9 MM10
- 895/1 MM105
- 895/3 MM105
- 895/6 MM105
- 900 MM105
- 900L MM105
- 900ME MM105
- 900LP MM105
- 900PH MM105
- 900TX MM105
- 900/16 MM105
- 900/20 MM105
- 900/20L MM105
- 900/21 MM105
- 900/25 MM105
- 900BG/30 MM105
- 900/42 MM105
- 900/55 MM105
- 910A MM105
- 910/15 MM105
- 910/16 MM105
- 910/21 MM105
- 910/22 MM105

N. pezzi/Descrizione

- 1 snodo 3/8"
- 1 quadro maschio 3/8" con spina scorrevole 210 mm
- 1 cricchetto reversibile 3/8" \varnothing 200 mm
- 21 chiavi a bussola esagonali 1/2" \varnothing 8-10-11-12-13-14-15-16-17-18-19-20-21-22-23-24-26-27-28-30-32 mm
- 1 raccordo con attacco quadro \square 1/2 - \blacksquare 3/8
- 1 snodo 1/2"
- 1 prolunga angolare - 1/2" 125 mm
- 1 prolunga angolare - 1/2" 250 mm
- 1 quadro maschio 1/2" con spina scorrevole 305 mm
- 1 cricchetto reversibile 1/2" \varnothing 275 mm
- 1 chiavi a bussola per candele 3/8" \varnothing 16 mm (5/8")-17,8 (11/16")-20,8 (13/16")
- 1 tronchesi a grande effetto taglienti diagonali ζ 160 mm
- 1 pinza universale \equiv 180 mm
- 1 pinza a becchi mezzotondi dritti \bullet 160 mm
- 1 pinze becchi dritti per anelli elastici, per fori \varnothing 19+60 mm
- 1 pinze becchi piegati per anelli elastici, per fori \varnothing 19+60 mm
- 1 pinze becchi dritti per anelli elastici, per alberi \bullet 19+60 mm
- 1 pinze becchi piegati per anelli elastici, per alberi \bullet 19+60 mm
- 1 pinze regolabili cerniera chiusa 250 mm
- 1 pinza autobloccante 240 mm
- 38 microgiravite con 36 inserti intercambiabili da 4 mm e prolunga magnetica
- 6 giravite lama piatta \bullet 0,4x2,5x50-0,5x3x75-0,8x4x100-1,0x5,5x125-1,2x6,5x150-1,2x8x200 mm
- 1 giravite per viti a testa con intaglio \bullet 0,8x4x30 mm
- 4 giravite Phillips® \bullet PH0x60-PH1x80PH2x100PH3x150 mm
- 1 giravite Phillips® \bullet PH1x30 mm
- 12 chiavi maschio con impugnatura per viti con impronta Torx® \varnothing T06-T07-T08-T09-T10-T15-T20-T25-T27-T30-T40-T45
- 1 giravite cercafase \bullet 0,5x3,5x100 mm

Beta N.

TR

- 910/25 MM105
- 910/42 MM105
- 910/55 MM105
- 920A MM105
- 920/15 MM105
- 920/25 MM105
- 920AN MM105
- 920AN MM105
- 920/42 MM105
- 920/55 MM105
- 956E MM105
- 1084BM MM140
- 1150BM MM140
- 1166BM MM140
- 1032 MM140
- 1034 MM140
- 1036 MM140
- 1038 MM140
- 1048 MM140
- 1052 MM140
- 1256/C36-2 MM140
- 1201E MM210
- 1201EN MM210
- 1202E MM210
- 1202EN MM210
- 1207E/TX MM210
- 1253 MM210



5945VUM 2.235,00 059451001

Assortimento consigliato in abbinamento con C45

Autoriparazione



N. pezzi/Descrizione

5	cacciaspina Ø 2-3-4-5-6 mm
1	bulino Ø 4 mm
1	scalpelli piatti 125 mm
18	chiavi combinate 6+22 - 24 mm
8	chiavi a forchetta 6x7 - 8x9 - 10x11 - 12x13 - 14x15 - 16x17 - 18x19 - 20x22 mm
3	chiavi poligonali curve 12x13 - 14x15 - 17x19 mm
13	chiavi maschio esagonale piegate ○ 2+10 - 12 mm
4	chiavi a bussola Macchina 1/2" ○ 17 - 19 - 21 - 22 mm
20	chiavi a bussola esagonali 1/2" ○ 10-11-12-13-14-15-16-17-18-19-20-21-22-23-24-26-27-28-30-32 mm
1	prolunga - 1/2"
1	prolunga - 1/2"
1	snodo 1/2"
1	quadro maschio 1/2" con spina scorrevole
1	cricchetto reversibile 1/2" ⊕
3	chiavi a bussola con impugnatura, tipo lungo ○ 8 - 10 - 13 mm
10	chiavi a T con bussola snodata ○ 6 - 7 - 8 - 10 - 11 - 12 - 13 - 14 - 17 - 19 mm
3	chiavi a bussola per candele ○ 16 - 17,8 - 20,8 mm
1	leva con estremità a punta e a becco
1	pinze becchi dritti per anelli elastici, per fori ○
1	pinze becchi piegati per anelli elastici, per fori ○
1	pinze becchi dritti per anelli elastici, per alberi ●
1	pinze becchi piegati per anelli elastici, per alberi ●
1	pinze regolabili cerniera chiusa 250 mm
1	pinza autobloccante 240 mm

Beta N.

31
32
34
42NEW
55
90
96
720
920A
920/21
920/22
920/25
920/42
920/55
943BX
952
956C
964
1032
1034
1036
1038
1048
1052

N. pezzi/Descrizione

1	pinza autobloccante becchi lunghi 175 mm
1	tronchesi a taglienti diagonali 160 mm
1	forbici per elettricisti lame dritte
1	pinza universale = 180 mm
1	pinza a becchi mezzotondi dritti ● 160 mm
1	giravite provacircuito ● 6+24V
1	giravite lama piatta ● 8 x 200 mm
1	giravite nano lama piatta ● 6,5x30 mm
1	giravite per viti con impronta a croce Phillips® ⊕ 8 x 150 mm
1	giraviti nano Phillips® ⊕ PH2x30 mm
5	chiave maschio per viti con impronta Torx® ⊕ T8 - T10 - T15 - T20 - T25
8	giravite
1	martello tipo tedesco 300 g
1	mazzuola antirimbazzo Ø 35 mm
1	pinza molle freni 210 mm
1	pinza per capicorda non isolati
1	flessometro 5 m
1	spessimetro
1	flessibile magnetico 1,8 kg
6	lime ad ago 160 mm
1	oliatore in plastica a pressione 150 cc

Beta N.

1058
1082BM
1128BMX
1150BM
1166BM
1254
1260
1260N
1262
1262N
1267TX
1263/D8
1370
1392
1470
1603
1692
1708/20
1712E/2
1720/B6
1754



5954VG

1.895,00 059541054

Assortimento consigliato in abbinamento con C54S-C55C

Autoriparazione

 36,6 kg

N. pezzi/Descrizione

6	cacciaspina Ø 2 - 3 - 4 - 5 - 6 - 8 mm
6	2 punzoni, 1 bulino, 3 scalpelli con supporto
17	chiavi combinate 6-7-8-10-11-12-13-14-15 16-17-19-21-22-24-27-30 mm
12	chiavi a forchetta 6x7 ÷ 30x32 mm
8	chiavi maschio esagonale con impugnatura 2 ÷ 10 mm
1	chiavi maschio esagonale piegate Ø 2,5 ÷ 12 mm
8	chiavi maschio piegate per viti con impronta Torx® ⌘ T9 ÷ T40
5	○ M5 ÷ M12
1	chiave regolabile a rullino 250 mm
1	chiavi dinamometriche a scatto ⌘ 1/2", 40÷200 Nm
13	chiavi a bussola esagonali 1/2" con guida ○ 10÷22 mm
8	chiavi a bussola esagonali 1/2" con guida ○ 23÷32 mm
4	chiavi a bussola a giravite lama piatta 1/2" ● 1,2x6,5 - 1,2x8 - 1,6x9 - 2x12 mm
3	chiavi a bussola a giravite lama Phillips® 1/2" ⌘ PH2 - 3 - 4
1	prolunga - 1/2" 125 mm
1	prolunga - 1/2" 255 mm
1	snodo 1/2"
1	quadro maschio 1/2" con spina scorrevole
1	cricchetto reversibile 1/2" ⌘
2	chiavi a bussola Macchina 1/2" ○ 17 - 19 mm
10	chiavi a T con bussola snodata ○ 7 - 8 - 10 - 11 - 12 - 13 - 14 - 15 - 17 - 19 mm
3	chiavi a T con bussola snodata per candele 14 - 16 - 20,8 mm
1	leva con estremità a punta e piatta curva
1	chiave a croce ○ ■ 1/2" - 17 - 19 - 22 mm
2	pinze becchi diritti per anelli elastici, per fori ○ 140 - 180 mm
2	pinze becchi piegati per anelli elastici, per fori ○ 130 - 170 mm
2	pinze becchi diritti per anelli elastici, per alberi ● 140x1,3 - 175 mm

Beta N.

31/SP6
38/SP6
42NEW
55/S12X
96T/S8
96N/G7
97TX/SC8
98XZN/B5
111
666N/20
920A/SB13
920A/SB8
920LP
920PH
920/21
920/22
920/25
920/42
920/55
720
952
959
963
979
1032
1034
1036

N. pezzi/Descrizione

2	pinze becchi piegati per anelli elastici, per alberi ● 135x1,3 - 175 mm	1038
1	pinze regolabili cerniera chiusa 250 mm	1048
1	pinza autobloccante 240 mm	1052
1	tronchesi a taglienti diagonali ⚡ 160 mm	1082BM
1	tronchesi a grande effetto taglienti diagonali ⚡ 160 mm	1084BM
1	tronchesi doppia leva taglio frontale ⚡ 180 mm	1092V
1	cesoia a lame larghe diritte 250 mm	1112
1	forbici per elettricisti lame diritte	1128BMX
1	pinza universale = 180 mm	1150BM
1	pinza a becchi mezzotondi diritti ● 160 mm	1166BM
1	pinza a becchi mezzotondi piegati ● 200 mm	1168BM
2	giravite lama piatta ● 8x200 - 10x200 mm	1260
1	giravite per viti con impronta a croce Phillips® ⌘ PH3x150 mm	1262
8	giravite	1263/D8
2	martello tipo tedesco 300 - 600 g	1370
1	mazzuola con battenti in materiale plastico Ø 35 mm	1390
11	estrattori a rulli per viti prigioniere M5÷M16 mm	1433/C11
1	chiave regolabile a nastro per filtri olio	1491
1	provatensione	1498
1	flessometro 5 m	1692
1	spessimetro	1708/20
1	flessibile magnetico 1,8 kg	1712E/2
1	raschietto a due taglienti 200 mm	1717A
1	raschietto a tre taglienti 200 mm	1717B
5	lime a taglio mezzodolce 200 mm	1719BMA8/S5
1	seghetto	1725
1	oliatore in metallo a pressione 200 cc	1751
1	cutter con lama a settori	1771
1	calibro a corsoio	1650













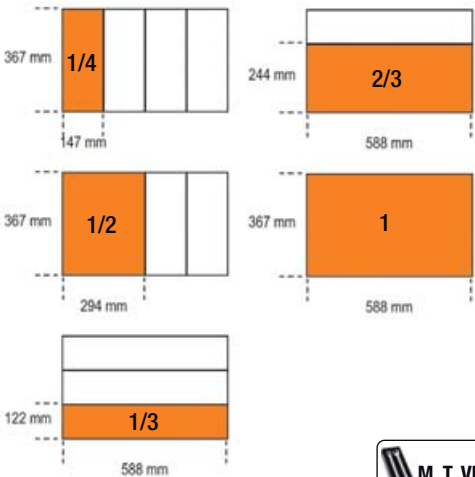

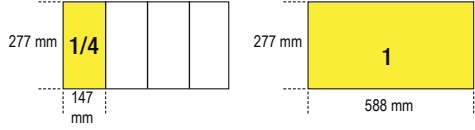

5957VG 3.300,00 059571007

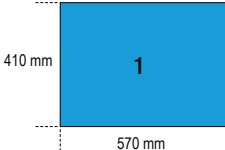
Assortimento consigliato in abbinamento con C57SA - C57SB - C57SP

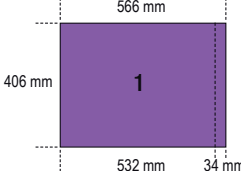
MODULI MORBIDI

Assortimenti di utensili in moduli morbidi per cassettiere e carrelli.

		
C23ST C24S C24SA C24SA-XL C24SL C28 C30S C37 C39 C39T C39MD C39SM C57S C59 RSC55	 	440÷448 453÷463
C22S C23S C23SC C27S	 	449 463
C41S C41H	 	449
C04TSS C38 C38T	 	453 463
C45	 	452
C35	 	449÷451



M01

22



42NEW 6-7-8-9-10-11-12-13-14-15-16-17-18-19-20-21-22-24-27-30-32-36 mm

4,5 kg



M01	€ 371,00	1	024500001
MV10	€ 48,00	1	024510010

M02

26



42NEW 6-7-8-9-10-11-12-13-14-15-16-17-18-19-20-21-22-23-24-25-26-27-28-29-30-32 mm

6,3 kg



M02	€ 420,00	1	024500002
MV02	€ 48,00	1	024510002

M05

16



42NEW 6-7-8-9-10-11-12-13-14-15-16-17-18-19-20-21 mm

1,5 kg



M05	€ 182,50	1	024500005
MV15	€ 25,00	1	024510015

M06

5



42NEW 22-24-27-30-32 mm

2,1 kg



M06	€ 130,00	1	024500006
MV16	€ 34,00	1	024510016

M13

11



42SLIM 8-10-11-12-13-14-15-16-17-18-19 mm

1,2 kg



M13	€ 131,00	1	024500013
MV13	€ 25,00	1	024510013

M25

40



42NEW 6-7-8-9-10-11-12-13-14-15-16-17-18-19-21-22-24-27 mm
90 6x7-8x9-10x11-12x13-14x15-16x17-18x19 mm

123Q1/4

123Q3/8

123Q1/2

142

8-9-10-11-12-13-14-15-16-17-18-19 mm

5,1 kg



M25	€ 588,00	1	024500025
MV25	€ 48,00	1	024510873

M30

31



55 6x7-8x9-10x11-12x13-14x15-16x17-18x19-20x22-21x23-24x27-30x32 mm
90 6x7-8x9-10x11-12x13-14x15-16x17-18x19-20x22-21x23-24x27-30x32 mm
96BPC/SC9 1,5-2-2,5-3-4-5-6-8-10 mm

4,2 kg



M30	€ 338,00	1	024500030
MV30	€ 48,00	1	024510030



M31

27



42AS 1/4-9/32-5/16-3/8-7/16-1/2-9/16-19/32-5/8-11/16-3/4-13/16-7/8-15/16-1-1-1/16-1-1/8-1-1/4

96BP/AS-SC9 1/16-3/32-1/8-5/32-3/16-7/32-1/4-5/16-3/8

4,5 kg



M31	€ 355,00	1	024500031
MV31	€ 48,00	1	024510031

M33

17



55 6x7-8x9-10x11-12x13-14x15-16x17-18x19-20x22 mm
96/SC9 1,5+10 mm

1,1 kg



M33	€ 82,00	1	024500033
MV33	€ 25,00	1	024510033

M38

4



55 21x23-24x26-27x29-30x32 mm

1,7 kg



M38	€ 68,50	1	024500038
MV38	€ 34,00	1	024510038

M39

36



- 31 2-3-4-5-6-8 mm
- 32 4 mm
- 55 6x7-8x9-10x11-12x13-14x15-16x17-18x19-20x22-21x23-24x26-25x28-27x29-30x32 mm
- 96/SC12 2-2,5-3-3,5-4-4,5-5-5,6-7-8-9-10 mm
- 96 12-14-17-19 mm

5,7 kg



M39	281,00	1	024500039
MV39	48,00	1	024510039

M40

7



- 90 6x7-8x9-10x11-12x13-14x15-16x17-18x19 mm

810 g



M40	91,50	1	024500040
MV40	25,00	1	024510040

M44

12



- 141 8-9-10-11-12-13-14-15-16-17-18-19 mm

1,3 kg



M44	233,50	1	024500044
MV44	25,00	1	024510044

M45

12



- 142 8-9-10-11-12-13-14-15-16-17-18-19 mm

1,3 kg



M45	265,00	1	024500045
MV45	25,00	1	024510045

M46

12



- 142SN 8-9-10-11-12-13-14-15-16-17-18-19 mm

1,4 kg



M46	315,00	1	024500046
MV46	25,00	1	024510046

M49

24



- 52MQ 7-8-10-11-12-13-14-15-16-17-19-22 mm
- 89MQ 7-8-10-11-12-13-14-15-16-17-19-22 mm

3,3 kg



M49	914,00	1	024500049
MV49	48,00	1	024510049

M50

8



- 96T 2-2,5-3-4-5-6-7-8 mm

1,1 kg



M50	109,00	1	024500050
MV50	34,00	1	024510051

M52

5



- 96T 2,5-3-4-5-6 mm

330 g



M52	63,00	1	024500052
MV52	25,00	1	024510052

M53

5



- 96TBP 2,5-3-4-5-6 mm

350 g



M53	67,00	1	024500053
MV52	25,00	1	024510052

M55

5



- 97TTX T10-T15-T20-T25-T30

330 g



M55	70,00	1	024500055
MV55	25,00	1	024510055



M60

23



- 96T 2-2,5-3-4-5-6-7-8-10 mm
- 97BTX/SC8 T9-T10-T15-T20-T25-T27-T30-T40
- 944BX 5-6-7-8-10-13 mm

1,9 Kg

M60	€ 318,00	1	024500060
MV60	€ 48,00	1	024510060

M62

21



- 97TTX T10-T15-T20-T25-T27-T30-T40-T45-T50
- 1032 180 mm
- 1034 170 mm
- 1036 175 mm
- 1038 175 mm
- 1177BM 140 mm
- 1188BM 125 mm
- 1257LP 2-2,5-3-3,5 mm
- 1257PH 0-0

2,3 kg

M62	€ 370,00	1	024500875
MV62	€ 48,00	1	024510875

M63

8



- 952 7-8-10-12-13-14-17-19 mm

3,4 kg

M63	€ 290,00	1	024500063
MV63	€ 48,00	1	024510063

M65

16

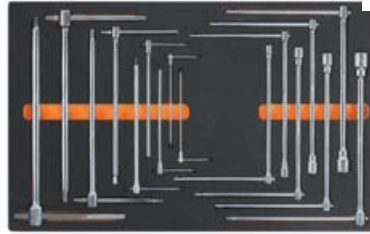

- 950 8-10-12-13-14-17-19 mm
- 951 2,5-3-4-5-6-8-10-12-14 mm

3,6 Kg

M65	€ 437,00	1	024500065
MV65	€ 48,00	1	024510065

M69

9



- 951 2,5-3-4-5-6-8-10-12-14 mm

1,8 kg

M69	€ 250,00	1	024500069
MV69	€ 34,00	1	024510069

M75

16



- 933 7-8-9-10-11-12-13-14-15-16-17-18-19-21-22-24 mm

5,5 kg

M75	€ 369,00	1	024500075
MV75	€ 48,00	1	024510075

M78

17



- 80 6x7-8x9-10x11-12x13-14x15-16x17-18x19 mm
- 920/36A
- 965 450 mm
- 1052 240 mm
- 1058 175 mm
- 1481PL/A
- 1481PL/B
- 1481PL/C
- 1650 150 mm
- 1708/20
- 1716P

4,4 kg

M78	€ 559,00	1	024500878
MV77	€ 48,00	1	024510876

M79

6



- 80 8x9-10x11-12x13-14x15-16x17-18x19 mm

1,3 kg

M79	€ 246,50	1	024500079
MV79	€ 25,00	1	024510079

M82

29



- 920A 10-11-12-13-14-15-16-17-18-19-20-21-22-23-24-26-27-30-32 mm
- 920ME 5-6-8-10-12 mm
- 920AN/125 125 mm
- 920AN/250 250 mm
- 920/25
- 920/42 305 mm
- 920/55

4,1 kg

M82	€ 369,00	1	024500082
MV82	€ 34,00	1	024510082



M83



- 920A 10-11-12-13-14
15-16-17-18-19
20-21-22-23-24
26-27-30-32 mm
- 920AN/125 125 mm
- 920AN/250 250 mm
- 920/25 255 mm
- 920/42 305 mm
- ⊕ 920/55

3,7 kg

12"

M83	297,00 €	1	024500083
MV83	34,00 €	1	024510083

M85



- 851SR 230 mm
- 860LP 0,5x3 - 0,6x4,5
- 0,8x5,5 - 1x5,5 -
1,2x6,5 mm
- 860PE 2 - 2,5 - 3 - 4 - 5 - 6 - 8
- 10 mm
- ⊕ 860PH PH0 - PH1 - PH2 -
PH3 - PH4
- ⊕ 860PZ PZ1 - PZ2 - PZ3 - PZ4
- ⊕ 860TX T6-T7-T8-T9-T10-T15-
T20-T25-T27-T30-T40
- ⊕ 860RTX T9-T10-T15-T20-T25-
T27-T30-T40
- 860/55 100 mm
- 882P 80 mm
- 892 ■ 1/4 - □ 1/4

450 g

1/4"

M85	162,50 €	1	024500085
MV85	25,00 €	1	024510085

M86



- 867PE 4-5-6-7-8-10-12 mm
- 867PE/L 4-5-6-7-8-10-12 mm
- 867XZN 5-6-8-10-12 mm
- 867XZN/L 5-6-8-10-12 mm
- ⊕ 867TX T20-T25-T30-T40-
T45-T50-T55
- ⊕ 867TX/L T25-T30-T40-T45-
T50-T55
- ⊕ 867RTX T20-T25-T30-T40-
T45-T50-T55
- 867/1
- 867/2

1,4 kg

10mm

M86	117,50 €	1	024500086
MV86	25,00 €	1	024510086

M91



- 900 4-4,5-5-5,5-6-7-8-9-
10-11-12-13-14 mm
- 900ME 2,5-3-4-5-6-8 mm
- 900/20 50 mm
- 900/21 150 mm
- 900/25 □ 1/4 - ■ 1/4
- 900BG/30
- 900/42
- ⊕ 900/55

560 g

1/4"

M91	198,50 €	1	024500091
MV90	25,00 €	1	024510090

M92



- 910A 6-7-8-9-10-11-12-13-
14-15-16-17-18-19-20-
21-22 mm
- 910/21 125 mm
- 910/22 250 mm
- 910/25
- 910/42
- ⊕ 910/55

1,5 kg

3/8"

M92	223,50 €	1	024500092
MV92	25,00 €	1	024510092

M94



- 900AS/L 3/16-7/32-1/4-9/32-
5/16-11/32-3/8-7/16-
1/2-9/16
- 900AS 3/16-7/32-5/32-1/4-
9/32-5/16-11/32-3/8-
7/16-1/2-9/16
- 900AN 50-100mm
- 900/25
- ⊕ 900/55
- 900/42

930 g

1/4"

M94	230,00 €	1	024500094
MV94	25,00 €	1	024510094

M96



- 920A/AS 3/8-7/16-1/2-9/16-
19/32-5/8-11/16-3/4-
25/32-13/16-7/8-
15/16-1-1.1/16-1.1/8-
1.3/16-1.1/4
- 920/25
- 920AN 125-250mm
- 920/42
- ⊕ 920/55

3,8 kg

12"

M96	305,00 €	1	024500096
MV96	34,00 €	1	024510096

M100



- 895/1
- 895/3
- 895/6
- 900 4-4,5-5-5,5-6-7-8-9-10-11-12-13-14 mm
- 900L 5-6-7-8-9-10-11-12-13 mm
- 900ME 3-4-5-6-7 mm
- 900LP 0,8x4-1x5,5-1,2x6,5-1,2x8 mm
- ⊕ 900PH PH1-PH2-PH3-PH4
- ⊕ 900TX T10-T15-T20-T25-T27-T30-T40
- 900/20 50 mm
- 900/20L 100 mm
- 900/21 150 mm
- 900/25
- 900BG/30
- 900/42
- ⊕ 900/55
- 920A 8-10-11-12-13-14-15-16-17-18-19-20
21-22-23-24-26-27-28-30-32 mm
- 920/15
- 920/25
- 920AN/125 125 mm
- 920AN/250 250 mm
- 920/42
- ⊕ 920/55
- 920FTX 10-12-14-16-18-20-22-24 mm
- 920AL 10-12-13-14-15-16-17-18-19-21-22

6,7 Kg

1/4" 1/2"

M100	1.015,00 €	1	024500100
MV100	48,00 €	1	024510100



M105

116



- 900 4-4,5-5-5,5-6-7-8-9-10-11-12-13-14 mm
- 900L 5-6-7-8-9-10-11-12-13 mm
- 96BPC/SC9 1,5-2-2,5-3-4-5-6-8-10 mm
 - 895/1
 - 895/3
 - 895/6
- 900ME 3-4-5-6-7 mm
- 900LP 0,8x4-1x5,5-1,2x6,5-2x8 mm
- 900PH PH1-PH2-PH3-PH4
- 900TX T10-T15-T20-T25-T27-T30-T40
 - 900/16 □ 1/4 - ■ 3/8
 - 900/... 50-100-150 mm
 - 900/25
 - 900BG/30
 - 900/42
- ⊕ 900/55
- 910A 6-7-8-9-10-11-12-13-14-15-16-17-18-19-20-21-22 mm
 - 910/15 □ 3/8 - ■ 1/4
 - 910/16 □ 3/8 - ■ 1/2
 - 910/21 125 mm
 - 910/22 250 mm
 - 910/25
 - 910/42
- ⊕ 910/55
- 920A 8-10-11-12-13-14-15-16-17-18-19-20-21-22-23-24-26-27-28-30-32 mm
 - 920/15 □ 1/2 - ■ 3/8
 - 920/25
 - 920AN 125 - 250 mm
 - 920/42
- ⊕ 920/55
- 956E 16-17,8-20,8 mm

7,7 kg

14" 38" 12"

M105	1.097,00 €	1	024500871
MV105	48,00 €	1	024510871



M108

27



- 910MQ/PE 4-5-6-8 mm
- 910MQ/B 7-8-10-11-12-13-14-15-16-17-19 mm
- 910MQ/TX T15-T20-T25-T27-T30-T40
- 910MQ/XZN 8-10 mm
 - 910MQ/21 125 mm
 - 910MQ/22 250 mm
 - 910MQ/T
 - 910MQ/55

2,7 kg

M108	1.015,00 €	1	024500108
MV108	48,00 €	1	024510108

M110

36



- ⊕ 850MQ
- 860TX/A10
- 920MQ/A 8-9-10-11-12-13-14-15-16-17-18-19-20 mm
- 920MQ/PE 5-6-8-10-12 mm
 - 920MQ/21 125 mm
 - 920MQ/22 250 mm
 - 920MQ/55A
- 943MQ 6-7-8-10 mm

3,1 kg

M110	1.022,00 €	1	024500110
MV110	48,00 €	1	024510110

M112

32



- 861TX ● 1/4-T6+T15
- 866TX ● 5/16-T20+T55
- 895/1 ○ 1/4x□1/4
- 895/6 ○ 5/16x□1/2
- 900FTX □ 1/4-E4+E10
- 920FTX □ 1/2-E12+E24
- 920TX □ 1/2-T55L-T60-T70L

1,3 kg

14" 12"

M112	257,00 €	1	024500112
MV112	25,00 €	1	024510112

M115

54



- ⊕ 666N 40+200 Nm
- 920A 13-14-15-16-17-18-19-20-21-22-24-26-27-30-32 mm
- 920FTX 12-14-16-18-20-22-24 mm
- 920PE 6-7-8-8L-10-10L-12-12L-14-14L
- 920TX T20-T25-T27-T30-T40-T45-T50-T55-T60-T20L-T25L-T27L-T30L-T40L-T45L-T50L
 - 920/21 125 mm
 - 920/22 255 mm
 - 920/25
 - 920/42 305 mm
- ⊕ 920/55

7,8 Kg

12"

M115	962,00 €	1	024500115
MV115	48,00 €	1	024510115

M120

75



- 920A 10-11-12-13-14-15-16-17-18-19-20-21-22-24-26-27-30-32 mm
 - 920AN/125 125 mm
 - 920AN/250 250 mm
 - 920/25
 - 920/42
- 920AL 10-12-13-14-15-16-17-18-19-22-24-27-30-32 mm
- 920FTX 10-12-14-16-18-20-22-24 mm
- ⊕ 920/55
- 920PE 5-5L-6-6L-7-7L-8-8L-10-10L-12-12L-14-14L
- 920TX T20-T25-T27-T30-T40-T45-T50-T55-T60-T20L-T25L-T27L-T30L-T40L-T45L-T50L

6,9 Kg

12"

M120	1.088,00 €	1	024500120
MV120	48,00 €	1	024510120

M121

46



- 920BP 5L-6L-8L-10L-5XL-6XL-8XL mm
- 920TX T20-T25-T27-T30-T40L-T45L-T50L-T55L-T60L-T70L
- 920XZN 4-5-6-6L-8-8L-10-10L-12-12L-14-14L-16-18 mm
- 920ES 7-9-10-11-12L-14L-16L-7XL-9XL-10XL-11XL-12XL-14XL-16XL mm

920/36A

12"

6,3 Kg

M121	1.023,00 €	1	024500121
MV121	48,00	1	024510121

M125

68



- 910AL 8-9-10-11-12-13-14-15-16-17-19-21-22 mm
- 920PE 5-6-6L-7-8-8L-10-10L-12-12L mm
- 920FTX E12-E14-E16-E18-E20-E22-E24
- 920TX T20-T25-T27-T30-T30L-T40-T40L-T45-T50-T50L-T55-T60-T60L
- 920XZN 5-6-6L-8-8L-10-10L-12L mm
- 920AL 10-12-13-14-15-16-17-18-19-21-22-23-24-27-30-32 mm

1692/5

38" 12"

7,9 kg

M125	1.066,00 €	1	024500872
MV125	48,00	1	024510872

M126

26



- 928A 19-21-22-24-26-27-28-30-32-34-35-36-38-41-46 mm
- 928ME 14-17-19-22 mm
- 928/15 □ 3/4 - ■ 1/2
- 928/16 □ 3/4 - ■ 1
- 928/21 200 mm
- 928/22 380 mm
- 928/25
- 928/42 450 mm
- 928/55

34"

12,4 kg

M126	814,00 €	1	024500126
MV126	48,00	1	024510126

M127

23



- 728 19-21-22-24-27-30-32-33-34-35-36-38-40-41-46
- 728FTX 20-22-24 mm
- 728/15 □ 3/4 - ■ 1/2
- 728/16 □ 3/4 - ■ 1
- 728/21 175 mm
- 728/22 250 mm
- 728/25

34"

12,5 kg

M127	768,00 €	1	024500127
MV127	48,00	1	024510127

M128

50



- 720 10-11-12-13-14-15-16-17-18-19-21-22-24-27-30-32 mm
- 720L 10-11-12-13-14-15-16-17-18-19-21-22-24-27-30-32 mm
- 720TX T30-T40-T45-T50-T55
- 720ME 5-6-8-10-12-14-17-19 mm
- 720LC 17-19-21 mm
- 720/21 125 mm
- 720/25

12"

8,9 kg

M128	789,00 €	1	024500128
MV128	48,00	1	024510128

M129

13



- 1032 180 mm
- 1034 170 mm
- 1036 175 mm
- 1038 175 mm
- 1048 250 mm
- 1052 240 mm
- 1082BM 160 mm
- 1098 220 mm
- 1112 250 mm
- 1128BM
- 1150BM 180 mm
- 1166BM 160 mm
- 1168BM 160 mm

3,4 Kg

M129	353,00 €	1	024500129
MV130	48,00	1	024510130

M133

3



- 1082G 160 mm
- 1150G 180 mm
- 1166G 160 mm

650 g

M133	67,50 €	1	024500133
MV133	25,00	1	024510133

M134

3



- 1082GBM 160 mm
- 1150GBM 180 mm
- 1166GBM 160 mm

750 g

M134	85,50 €	1	024500134
MV134	25,00	1	024510134

M135

3



- 1082MQ 160 mm
- 1150MQ 180 mm
- 1166MQ 160 mm

750 g

M135	144,00 €	1	024500135
MV135	25,00	1	024510135

M136

3



- 1084BM 160 mm
- 1150BM 180 mm
- 1166BM 160 mm

750 g

M136	97,50 €	1	024500136
MV131	25,00	1	024510131

M137

3



- 1084 160 mm
- 1150 180 mm
- 1166 160 mm

650 g



M137	80,00	1	024500137
MV132	25,00	1	024510132

M145

4



- 1032 180 mm
- 1034 170 mm
- 1036 175 mm
- 1038 175 mm

640 g



M145	109,50	1	024500145
MV145	25,00	1	024510145

M153

2



- 1048 250 mm
- 1052 240 mm

1 kg



M153	67,00	1	024500153
MV153	25,00	1	024510153

M161

15



- 1128MQ
- 1048MQ 250 mm
- 1082MQ 160 mm
- 1150MQ 180 mm
- 1162MQ 160 mm
- 1164MQ 160 mm
- 1272MQ PH0x60 - PH1x80 - PH2x100 - PH3x150 mm
- 1274MQ 2,5x75 - 3x100 - 4x100 - 5,5x125 mm
- 1777MQ/U

3,0 kg



M161	420,00	1	024500161
MV161	48,00	1	024510161

M162

8



- 1241 5,5x100-6,5x125-8x150-10x200 mm
- 1242 PH1x100-PH2x100-PH3x150-PH4x200 mm

1,4 kg



M162	120,50	1	024500162
MV162	34,00	1	024510162

M166

49



- 860MIX/A31
- 1048 250 mm
- 1082BM 160 mm
- 1150BM 180 mm
- 1162BM 160 mm
- 1290 3x75-4x100-5,5x100-6,5x150-8x150 mm
- 1290N 6,5x30 mm
- 1292 4,5x80-6x100-8x150 mm
- 1292N 6x30 mm
- 1297TX T20-T25-T27-T30

2,9 kg



M166	360,00	1	024500879
MV165	48,00	1	024510874

M170

7



- 1290 2,5x50
- 3x75
- 3,5x100
- 4x125
- 5,5x100
- 5,5x150
- 6,5x150 mm

500 g



M170	62,00	1	024500170
MV170	25,00	1	024510170

M172

6



- 1292 PH0x60
- PH0x100
- PH1x80
- PH1x120
- PH2x100
- PH2x150 mm

450 g



M172	56,50	1	024500172
MV172	25,00	1	024510172

M174

6



- 1297TX T8-T10-T15-T20-T25-T30

450 g



M174	82,50	1	024500174
MV174	25,00	1	024510174

M180

7



- 1290 3x75
- 4x100
- 5,5x150
- 6,5x150 mm
- 1292 PH0x60
- PH1x80
- PH2x100 mm

500 g



M180	64,50	1	024500180
MV180	25,00	1	024510180



M195

25



- 1260 2,5x50-3x75-4x100-5,5x125-6,5x150-8x200 mm
- 1260N 4x30 mm
- ⊕ 1262 PH0x60-PH1x80-PH2x100-PH3x150 mm
- ⊕ 1262N PH1X30 mm
- ⊖ 1267TX T6-T7-T8-T9-T10-T15-T20-T25-T27-T30-T40-T45
- 1253 3,5x100 mm

2,3 kg



M195	€ 252,00	1	024500195
MV195	€ 48,00	1	024510195

M199

7



- 1260 2,5x50-3x75-3,5x100-4x125-5,5x100-5,5x150-6,5x150 mm

500 g



M199	€ 50,50	1	024500199
MV199	€ 25,00	1	024510199

M202

6



- ⊕ 1262 PH0x60-PH0x100-PH1x80-PH1x120-PH2x100-PH2x150 mm

450 g



M202	€ 46,50	1	024500202
MV202	€ 25,00	1	024510202

M204

6



- ⊖ 1267TX T8-T10-T15-T20-T25-T30

450 g



M204	€ 64,50	1	024500204
MV204	€ 25,00	1	024510204

M208

10



- 1260 3x75-3,5x100-4x125-5,5x150-6,5x150 mm
- ⊕ 1262 PH0x60-PH1x80-PH2x100 mm
- 1260N 4x30 mm
- ⊕ 1262N PH1x30 mm

750 g



M208	€ 74,00	1	024500208
MV208	€ 34,00	1	024510208

M209

10



- 1260N 4x30 mm
- 1264 2,5x60 - 3x100 - 4x125 - 5x150 - 6,5x150 mm
- ⊕ 1262 PH0x60 - PH1x80 - PH2x100 mm
- ⊕ 1262N PH1x30 mm

820 g



M209	€ 73,50	1	024500209
MV208	€ 34,00	1	024510208

M213

25



- 1201E 2,5x50-3x75-4x100-5,5x125-6,5x150-8x200 mm
- 1201EN 4x30 mm
- ⊕ 1202E PH0x60-PH1x80-PH2x100-PH3x150 mm
- ⊕ 1202EN PH1X30 mm
- ⊖ 1207E/TX T6-T7-T8-T9-T10-T15-T20-T25-T27-T30-T40-T45
- 1253 3,5x100 mm

1,8 Kg



M213	€ 180,50	1	024500213
MV210	€ 48,00	1	024510210

M214

7



- 1201E 2,5x50-3x75-3,5x100-4x125-5,5x100-5,5x150-6,5x150 mm

500 g



M214	€ 37,00	1	024500214
MV211	€ 25,00	1	024510211

M216

6



- ⊕ 1202E PH0x60-PH1x80-PH1x120-PH2x100-PH2x150-PH3x150 mm

450 g



M216	€ 40,00	1	024500216
MV212	€ 25,00	1	024510212

Beta

Beta

M217



1207E/TX T6-T7-T8-T9-T10-T15-T20

500 g



M217	€ 51,50	1	024500217
MV215	€ 25,00	1	024510215

M218



1201E 3x75
4x100
5,5x150
6,5x150 mm
1202E PH0x60
PH1x80
PH2x100 mm

500 g



M218	€ 39,00	1	024500218
MV220	€ 25,00	1	024510220

M219



1202E 3x60 - 4,5x80 - 6x100 mm
1204E 3x75 - 4x100 - 5x150 - 6,5x150 mm

590 g



M219	€ 39,00	1	024500219
MV220	€ 25,00	1	024510220

M223



1272MQ PH0x60 mm
1272MQ/F PH1x80 - PH2x100 mm
1274MQ/F 3,5x100 - 4,5x100 - 5,5x125 - 6,5x150 mm

620 g



M223	€ 88,50	1	024500223
MV226	€ 25,00	1	024510226

M224



1272MQ PH0x60
PH1x80
PH2x100 mm
1274MQ/F 3,5x100
4,5x100
5,5x125
6,5x150 mm

630 g



M224	€ 86,00	1	024500224
MV226	€ 25,00	1	024510226

M226



1274MQ 3x100
4x100
5,5x125
6,5x150 mm
1272MQ PH0x60
PH1x80
PH2x100 mm

500 g



M226	€ 83,00	1	024500226
MV226	€ 25,00	1	024510226

M227



944BX 6-7-8-10-13 mm

420 g



M227	€ 107,00	1	024500227
MV227	€ 25,00	1	024510227

M230



30 Ø 2-3-4 mm
31 Ø 2-3-4-5-6-8 mm
32 Ø 4 mm
34 150 mm
35 200-250 mm
36 125 mm
1370 500 g
1390 Ø 35 mm
1692 3 m
1712TF
1719BMA/Q 200 mm
1719BMA/T 200 mm
1719BMA/P 200 mm
1719BMA/M 200 mm
1719BMA/R 200 mm
1737NX
1771 18 mm

3,2 Kg



M230	€ 333,00	1	024500230
MV230	€ 48,00	1	024510230

M231



31 2-3-4-5-6-8 mm
32 4 mm
34 125-150-175 mm
36 125 mm
1370 500-1000 g
1390 Ø 35 mm
1712TF 590 mm
1715 670 mm
1719BMA8/Q 200 mm
1719BMA8/T 200 mm
1719BMA8/P 200 mm
1719BMA8/M 200 mm
1719BMA8/R 200 mm
1737NX

4,7 kg



M231	€ 326,00	1	024500877
MV231	€ 48,00	1	024510877



M234

4



35 100-200 mm
1370 300 g
1390 Ø 35 mm

1,3 kg



M234 € 83,00 1 024500234
MV232 € 25,00 1 024510232

M236

5



■ 1719BMA/Q 200 mm
▲ 1719BMA/T 200 mm
■ 1719BMA/P 200 mm
▶ 1719BMA/M 200 mm
● 1719BMA/R 200 mm

870 g



M236 € 82,50 1 024500236
MV236 € 25,00 1 024510236

M237

4



35 100-200 mm
1370T 300 mm
1390N Ø 35 mm

1,3 kg



M237 € 90,50 1 024500237
MV232 € 25,00 1 024510232

M240

7



31BM Ø 2-3-4-5-6-8 mm
32 Ø 4 mm

850 g



M240 € 112,50 1 024500240
MV240 € 25,00 1 024510240

M264

16



1491 Ø 65+110 mm
■ 1494 ■ 10 mm
○ 1494E ○ 8-9-10-11-12-14-17 mm
○ 1494Q ○ 8-9,5-12-13 mm
△ 1494T △ 9,5
○ 1494XZN ○ 16
1496C ■ 8x ■ 10 mm

2,1 kg



M264 € 192,50 1 024500264
MV264 € 25,00 1 024510264

M284

9



1128BMX
1130BMX
1719BMA...Q 200 mm
1719BMA...P 200 mm
1719BMA...M 200 mm
1719BMA...R 200 mm
1726BM 400 mm
1728BM (5)
1771BM 170 mm
1778V18 185 mm

2,4 Kg



M284 € 196,50 1 024500284
MV284 € 48,00 1 024510284

M285

4



1112 250 mm
1128BM
1726 440 mm
1728BM (5)
1753 200 cc

1,5 kg



M285 € 102,50 1 024500285
MV285 € 48,00 1 024510285

M289

4



1692 5 m
1725CR
1755 30 cc
1771

500 g



M289 € 41,50 1 024500289
MV289 € 25,00 1 024510289

M292

4



111 250 mm
1128BMX
1692/5 5 m
1771 170 mm

500 g



M292 € 77,50 1 024500292
MV292 € 25,00 1 024510292

M295

4



1650
1682 L=300 mm
1707
1708/20

450 g



M295 € 96,50 1 024500295
MV295 € 25,00 1 024510295

M305

14



1927B
○ 720 12-13-14-15-16-17
18-19-21-22
24-27 mm
720/21

4,2 kg

12"



M305 € 339,00 1 024500305
MV305 € 34,00 1 024510305

M310

14



1927CD
 ○ 720 12-13-14-15-16-17
 18-19-21-22
 24-27 mm
 720/21

4,0 kg

12"



M310	554,00 €	1	024500310
MV310	34,00 €	1	024510310

MC10

34



42NEW	6-7-8-9-10-11-12 13-14-15-16-17 18-19-21-22 mm
96/SC9	1,5-2-2,5-3-4-5-6-8-10 mm
1084BM	160 mm
1150G	180 mm
1166G	160 mm
1201E	3,5x100-5,5x150-6,5x150 mm
1202E	PH0x60-PH1x80-PH2x100 mm

3,5 kg



MC10	321,00 €	1	027500011
MCV10	34,00 €	1	027510010

MC12

26



42NEW	6-7-8-9-10-11-12-13-14-15-16-17-18-19- 21-22 mm
96/SC9	1,5-2-2,5-3-4-5-6-8-10 mm
1692/5	5 m

2,2 kg



MC12	217,50 €	1	041500012
MCV11	34,00 €	1	041510011



MC20

74



860MIX/A31	
895/1	
1048	250 mm
1370	300 g
32	Ø 4 mm
36	Ø 4 mm
900	4-4,5-5-5,5-6-7-8-9-10-11-12-13-14 mm
900/21	150 mm
900/25	
900BG/30C	
900/42	
900/55	
920A	10-11-12-13-14-15-16-17-18-19-21-22- 24-27-30-32 mm
920/25	
920AN/125	125 mm
920/42	
920/55	

6 kg

12"



MC20	512,00 €	1	027500020
MCV20	34,00 €	1	027510020

MC21

24



920A	10-11-12-13-14-15-16-17-18-19-20-21- 22-23-24-26-27-30-32 mm
920/25	
920/42	
920/55	
920AN	125-250 mm

4,3 kg



MC21	297,00 €	1	041500021
MCV21	34,00 €	1	041510021

MB12

30



42NEW	6-7-8-9-10-11-12-13-14-15-16-17-18-19- 20-21-22-24-27-30-32 mm
55	6x7-8x9-10x11 12x13-14x15 16x17-18x19 20x22 mm
1048	250 mm

5,4 kg



MB12	409,00 €	1	024504212
MBV11	130,00 €	1	024524211

MB37

52



○ 920A	10-11-12-13-14-15-16-17-18-19-20-21- 22-23-24-26-27-30-32 mm
920/21	125 mm
920/22	150 mm
920/25	
920/42	
⊗ 920/55	
111	250 mm
1052	240 mm
⚡ 1084BM	160 mm
≡ 1150BM	180 mm
● 1166BM	160 mm
○ 1032	180 mm
○ 1034	170 mm
● 1036	175 mm
● 1038	175 mm
○ 900	4-4,5-5-5,5-6-7-8-9-10-11-12-13-14 mm
900/20	50 mm
900/21	150 mm
900/25	
900BG/30	
⊗ 900/55	
900/42	

7,0 kg



MB37	717,00 €	1	024504237
MBV34	130,00 €	1	024524234



MB38

80



- 96T 2-2,5-3-4-5-6-7-8 mm
- 851SR 230 mm
- 860LP 0,5x3 - 0,6x4,5 - 0,8x5,5 - 1x5,5 - 1,2x6,5 mm
- 860PE 2 - 2,5 - 3 - 4 - 5 - 6 - 8 - 10 mm
- ⊕ 860PH PH0 - PH1 - PH2 - PH3 - PH4
- ⊕ 860PZ PZ1 - PZ2 - PZ3 - PZ4
- ⊕ 860RTX T9-T10-T15-T20-T25-T27-T30-T40
- ⊕ 860TX T6-T7-T8-T9-T10-T15-T20-T25-T27-T30-T40
- 860/55 100 mm
- 882P
- 892/0
- 920A 10-11-12-13-14-15-16-17-18-19-20-21-22-23-24-26-27-30-32 mm
- 920/21 125 mm
- 920/22 255 mm
- 920/25
- 920/42
- ⊕ 920/55
- ⌘ 1084BM 160 mm
- ≡ 1150BM 180 mm
- 1166BM 160 mm

5,9 kg



MB38 660,00 € 1 024504238
MBV35 130,00 € 1 024524235

MB39

39



- 920A 10-11-12-13-14-15-16-17-18-19-20-21-22-23-24-26-27-30-32 mm
- 920/21 125 mm
- 920/22 255 mm
- 920/25
- 920/42
- ⊕ 920/55
- 920PE 5-6-8-10-12 mm
- 1032 180 mm
- 1034 170 mm
- 1036 175 mm
- 1038 175 mm
- 35 200 mm
- ⌘ 1084BM 160 mm
- ≡ 1150BM 180 mm
- 1166BM 160 mm
- 1370 500 g
- 1390 35 mm

7,2 kg



MB39 642,00 € 1 024504239
MBV36 130,00 € 1 024524236

MB44

34



- 1260 2,5x50-3x75-3,5x100-4x100-5,5x125-6,5x150-8x200 mm
- 1260N 4x30-6,5x30 mm
- ⊕ 1262 PH0x60-PH0x100-PH1x80-PH1x120-PH2x100-PH2x150-PH3x150 mm
- ⊕ 1262N PH1x30-PH2x30 mm
- 1253
- 96BPC/SC9
- 951 2,5-3-4-5-6-8 mm

2,8 kg



MB44 322,00 € 1 024504244
MBV44 130,00 € 1 024524244

MB45

29



- 1260 2,5x50-3x75-3,5x100-4x100-5,5x100-5x125-6,5x150 mm
- ⊕ 1262 PH0x60-PH0x100-PH1x80-PH1x120-PH2x100-PH2x150 mm
- ⊕ 1267TX T8-T10-T15-T20-T25-T30
- 1052 240 mm
- 96BPC/SC9

2,8 kg



MB45 239,50 € 1 024504245
MBV45 130,00 € 1 024524245

MB46

29



- 1260 3x75-4x100-5,5x125-6,5x150 mm
- ⊕ 1262 PH0x60-PH1x80-PH2x100 mm
- ⊕ 1267TX T8-T10-T15-T20-T25-T30
- 96BPC/SC9
- 96T 2-2,5-3-4-5-6
- 1052 240 mm

2,8 kg



MB46 266,00 € 1 024504246
MBV46 130,00 € 1 024524246

MB47

48



- 1260 3x75-4x100-5,5x125-6,5x150 mm
- ⊕ 1262 PH0x60-PH1x80-PH2x100 mm
- 1260N 4x30 mm
- ⊕ 1262N PH1x30 mm
- 96T 2,5-3-4-5-6-8 mm
- 96BPC/SC9
- 920A 10-11-12-13-14-15-16-17-18-19-20-21-22-23-24-26-27-30-32 mm
- 920/21 125 mm
- 920/22 250 mm
- 920/25
- 920/42
- ⊕ 920/55

5,6 kg

12"



MB47 529,00 € 1 024504247
MBV47 130,00 € 1 024524247

MB56

15



- 1719BMA/Q 200 mm
- ▲ 1719BMA/T 200 mm
- 1719BMA/P 200 mm
- ▶ 1719BMA/M 200 mm
- 1719BMA/R 200 mm
- 1032 180 mm
- 1034 170 mm
- 1036 175 mm
- 1038 175 mm
- 1370T 300 g
- 1390N Ø 35 mm
- 35 200 mm
- 1692 5 mt
- 1725CR 260 mm
- 1771 18 mm

3,7 kg



MB56 302,00 € 1 024504256
MBV56 130,00 € 1 024524256



MB59

15



1719BMA...Q	200 mm
1719BMA...T	200 mm
1719BMA...P	200 mm
1719BMA...M	200 mm
1719BMA...R	200 mm
31	Ø 4-6 mm
32	Ø 4 mm
35	125-200 mm
1370	300 g
1390	Ø 35 mm
1692	5 mt
1725	420 mm
1833XS/2	

3,4 kg

	€		
MB59	252,00	1	024504259
MBV57	130,00	1	024524257

MB58

17



31	Ø 2-3-4-5-6 mm
32	Ø 4 mm
35	200 mm
1112	250 mm
1128BMX	
1370	500 g
1390	Ø 45 mm
1719BMA...Q	200 mm
1719BMA...T	200 mm
1719BMA...P	200 mm
1719BMA...M	200 mm
1719BMA...R	200 mm
1726	440 mm

4,5 kg

	€		
MB58	302,00	1	024504258
MBV55	130,00	1	024524255

MB65

16



1719BMA...Q	200 mm
1719BMA...P	200 mm
1719BMA...T	200 mm
1719BMA...M	200 mm
1719BMA...R	200 mm
35	200 mm
1032	180 mm
1034	170 mm
1036	175 mm
1038	175 mm
1052	240 mm
1084BM	160 mm
1150BM	180 mm
1166BM	160 mm
1370	500 g
1390	Ø 35 mm

4,8 kg

	€		
MB65	388,00	1	024504265
MBV61	130,00	1	024524261



MB63

60

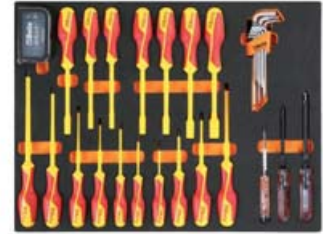

96BPC/SC9	
1250	4x125 mm
1251	PH1x150 mm
1253	
943MQ	5,5-6-7-8-10-13 mm
1272MQ	PH0x60-PH1x80-PH2x100-PH3x150 mm
1274MQ	2,5x75-3x100-4x100-5,5x125-6,5x150-8x175 mm
860LP	0,5x3 - 0,6x4 - 0,8x5,5 1,0x5,5 - 1,2x6,5 mm
860PE	2 - 2,5 - 3 - 4 - 5 - 6 8 - 10 mm
860PH	PH0 - PH1 - PH2 - PH3 - PH4
860PZ	PZ1 - PZ2 - PZ3 - PZ4
860RTX	T9 - T10 - T15 - T20 T25 - T27 - T30 - T40
882MSR/50	○ 1/4 ● 1/4
850MQ	

3,2 kg

	€		
MB63	402,00	1	024504263
MBV63	130,00	1	024524263

MB64

20



55	6x7-8x9-10x11 12x13-14x15 16x17-18x19 20x22 mm
1048MQ	250 mm
1082MQ	140 mm
1128BSX	
1132MQ	230 mm
1142MQ	160 mm
1150MQ	180 mm
1166MQ	160 mm
1168MQ	160 mm
110MQ	250 mm
1777MQ	
993MQ	
1602	

4,1 kg

	€		
MB64	674,00	1	024504264
MBV62	130,00	1	024524262

MM11

30



42NEW 6-7-8-9-10-11-12-13-14-15-16-17-18-19-20-21-22-24-27-30-32 mm
 96BPC/SC9 1,5-2-2,5-3-4-5-6-8-10 mm

4,5 kg



MM11	€ 344,00	1	024580011
MMV10	€ 48,00	1	024590010

MM61

17



96T 2-2,5-3-4-5-6-7-8 mm
 1390 Ø 35
 1370 300 g
 35 100-200 mm
 1719BMA8/S5 200 mm

2,9 kg



MM61	€ 263,00	1	024580061
MMV61	€ 48,00	1	024590061



MM105

107



895/1 □1/4 □1/4
 895/3 □1/4 □3/8
 895/6 □5/16 □1/2
 900 4-4,5-5-5,5-6-7-8-9-10-11-12-13-14 mm
 900L 5-6-7-8-9-10-11-12-13 mm
 900ME 3-4-5-6-7 mm
 900LP 0,8x4-1x5,5-1,2x6,5-1,2x8
 900PH PH1-PH2-PH3-PH4
 900TX T10-T15-T20-T25-T27-T30-T40
 900/16 50-100-150 mm
 900/25 176 mm
 900BG/30 115 mm
 900/42 125 mm
 900/55 125 mm
 910A 6-7-8-9-10-11-12-13-14-15-16-17-18-19-20-21-22 mm
 910/15 □3/8 ■1/4
 910/16 □3/8 ■1/2
 910/21 125 mm
 910/22 250 mm
 910/25 210 mm
 910/42 200 mm
 910/55 8-10-11-12-13-14-15-16-17-18-19-20-21-22-23-24-26-27-28-30-32 mm
 920A □1/2 ■3/8
 920/15 125-250 mm
 920/25 305 mm
 920/42 275 mm
 920/55 16 mm (5/8")-17,8 (11/16")-20,8 (13/16")

7,2 kg

14" 38" 12"

MM105	€ 1.060,00	1	024580105
MMV105	€ 48,00	1	024590105

MM140

52



97TTX T10-T15-T20-T25-T30
 1084BM 160 mm
 1150BM 180 mm
 1166BM 160 mm
 1032 180 mm
 1034 170 mm
 1036 175 mm
 1038 175 mm
 1048 250 mm
 1052 240 mm
 1256/C36-2

2,2 kg



MM140	€ 388,00	1	024580141
MMV140	€ 48,00	1	024590140

MM210

25



1201E 2,5x50-3x75-4x100-5,5x125-6,5x150-8x200 mm
 1201EN 4x30 mm
 1202E PH0x60-PH1x80-PH2x100-PH3x150 mm
 1202EN PH1X30 mm
 1207E/TX T6-T7-T8-T9-T10-T15-T20-T25-T27-T30-T40-T45
 1253

2,1 kg



MM210	€ 180,50	1	024580211
MMV210	€ 48,00	1	024590210



VPM0
termoformato morbido
con vaschetta portaminuterie



VPM0 € 19,50 1 088870350

VPM3
termoformato morbido
con 4 vaschette portaminuterie

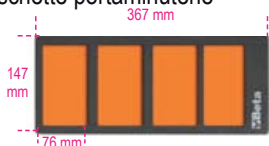

VPM3 € 19,50 1 088870353

VPM7
termoformato morbido con 3 vaschette
portaminuterie

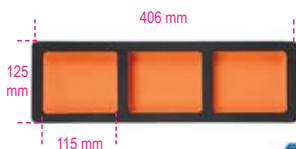

VPM7 € 21,00 1 088870356

VPM8
termoformato morbido con vaschetta
portaminuterie



VPM8 € 16,00 1 088870357

VPM9
termoformato morbido con vaschetta
portaminuterie



VPM9 € 15,50 1 088870358

VPM7-C

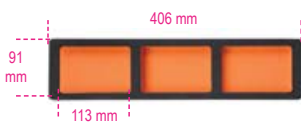

VPM7-C € 24,00 1 088870360

Termoformati rigidi serie T



Assortimenti di utensili in termoformato
per tutti i modelli di cassettiere e per i carrelli.

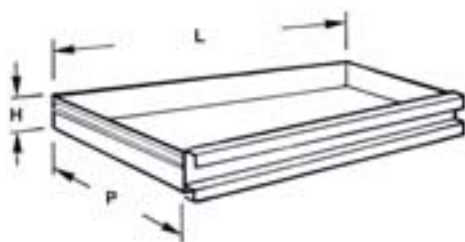

H mm 70
LxP mm 588x367

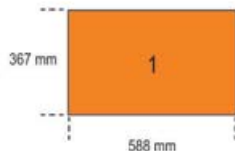
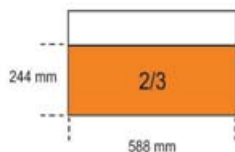
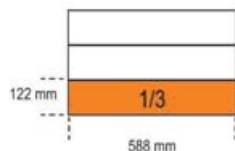
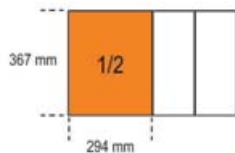
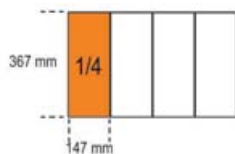

T01

17



42NEW 6-7-8-10-11-12-13
14-16-17-18-19-21
22-24-27-30 mm

2,7 kg



T01 € 227,00 1 024240001
TV10 € 24,50 1 024000400

T05

16



42NEW 6-7-8-9-10-11-12
13-14-15-16-17
18-19-20-21 mm

1,5 kg



T05 € 172,50 1 024240005
TV15 € 18,50 1 024000445

T06

5



42NEW 22-24-27-30-32 mm

2,1 kg



T06 € 123,50 1 024240006
TV16 € 18,50 1 024000446

T13

11



42SLIM 8-10-11-12
13-14-15-16-17
18-19 mm

1,5 kg



T13 € 124,50 1 024240013
TV13 € 18,50 1 024249913

T18

16



42MP 6-7-8-9-10-11-12
13-14-15-16-17
18-19-20-21 mm

1,5 kg



T18	€ 241,00	1	024240018
TV15	€ 18,50	1	024000445

T19

5



42MP 22-24-27-30-32 mm

2,1 kg



T19	€ 161,00	1	024240019
TV16	€ 18,50	1	024000446

T22

15



42AS 5/16-3/8-7/16-1/2
9/16-5/8-11/16-3/4
3/32-1/8-5/32-3/16
1/4-5/16-3/8

1 kg



T22	€ 131,00	1	024240022
TV20	€ 18,50	1	024000488

T23

16



42INOX 8-10-11-12-13-14-15-
17-19 mm
96BPINOX 2,5-3-4-5-6-8-10 mm



1 kg



T23	€ 216,50	1	024240023
TV23	€ 18,50	1	024249906

T31

27



31 Ø 2-3-4-5-6 mm
32 Ø 4 mm
55 6x7-8x9-10x11
12x13-14x15
16x17-18x19
20x22-21x23
24x26-27x29
30x32 mm
96N/SC9 1,5+10 mm

3 kg



T31	€ 182,50	1	024240031
TV30	€ 24,50	1	024000401

T33

17



55 6x7-8x9-10x11
12x13-14x15
16x17-18x19
20x22 mm
96/SC9 1,5+10 mm

1 kg



T33	€ 77,50	1	024240033
TV20	€ 18,50	1	024000488

T34

17



55MP 6x7-8x9-10x11
12x13-14x15
16x17-18x19
20x22 mm
96/SC9 1,5+10 mm

1 kg



T34	€ 100,00	1	024240034
TV20	€ 18,50	1	024000488

T40

7



90 6x7-8x9-10x11
12x13-14x15
16x17-18x19 mm

810 g



T40	€ 86,50	1	024240040
TV40	€ 18,50	1	024000456

T41

5



90 20x22-21x23
24x26-25x28
27x29 mm

1,5 kg



T41	€ 128,50	1	024240041
TV41	€ 18,50	1	024000457

T45

12



142 8-9-10-11-12
13-14-15-16
17-18-19 mm

1,3 kg



T45	€ 259,00	1	024240045
TV45	€ 18,50	1	024000498

T46

12



142SN 8-9-10-11-12
13-14-15-16
17-18-19 mm

1,5 kg



T46	€ 308,00	1	024240046
TV46	€ 18,50	1	024000499

T48

12



96BPC/SC9 1,5+10 mm
142C 8-9-10-11-12
13-14-15-16
17-18-19 mm

1,4 kg



T48	€ 222,00	1	024240048
TV47	€ 18,50	1	024000763

T50

11



○ 96T 2-2,5-3-3,5-4-4,5
5-6-7-8-10 mm

1,3 kg



T50	€ 145,00	1	024240050
TV50	€ 24,50	1	024000764

T52

6



○ 96T 2-2,5-3-4-5-6 mm

350 g



T52	€ 70,50	1	024240052
TV52	€ 18,50	1	024000765

T53

5



○ 96TBP 2,5-3-4-5-6 mm

300 g



T53	€ 63,00	1	024240053
TV52	€ 18,50	1	024000765

T55

6



○ 97TTX T10-T15-T20
T25-T27-T30

330 g



T55	€ 81,50	1	024240055
TV55	€ 18,50	1	024000766

T56

14



○ 96BP 2-3-4-5-6-8-10 mm
○ 97TX T20-T25-T30-T40-
T45-T50-T55

300 g



T56	€ 98,50	1	024240056
TV56	€ 18,50	1	024249901

T57

5



○ 96TINOX 2,5-3-4-5-6 mm



350 g



T57	€ 66,00	1	024240057
TV57	€ 18,50	1	024249907

T59

14



111 250 mm
920/40 ■ 1/2
○ 951 2,5-3-4-5-6-8 mm
○ 953 4-5-6-8 mm
1370 300 - 500 g

4,7 kg



T59	€ 365,00	1	024240059
TV60	€ 37,00	1	024000420

T63

8



○ 952 7-8-10-12-13-14-17-19 mm

3,8 kg



T63	€ 281,00	1	024240063
TV63	€ 31,00	1	024000471

T64

8



○ 952FTX E10-E12-E14
○ 953TX T25-T27-T30-T40-T45

3,8 kg



T64	€ 340,00	1	024240064
TV63	€ 31,00	1	024000471

T65

8



○ 953 3-3,5-4-5-6-7-8-10 mm

2,8 kg



T65	€ 268,00	1	024240065
TV63	€ 31,00	1	024000471

T68

6



○ 951 2,5-3-4-5-6-8 mm

590 g



T68	€ 119,00	1	024240068
TV68	€ 18,50	1	024000470

T73

8



○ 930 6x7-8x9-10x11-12x13-
14x15-16x17-18x19-
20x22 mm

940/1

940/2

1,3 kg



T73	€ 176,50	1	024240073
TV73	€ 18,50	1	024000418

T75

16



○ 933 7-8-9-10-11-12-13
14-15-16-17-18-19
21-22-24 mm

4,2 kg



T75	€ 359,00	1	024240075
TV75	€ 37,00	1	024000422

T76

16



○ 932 7-8-9-10-11-12-13
14-15-16-17-18-19
21-22-24 mm

4,2 kg



T76	€ 359,00	1	024240076
TV75	€ 37,00	1	024000422

T77

10



○ 933 6-7-8-10-11-12-13
14-17-19 mm

1,4 kg



T77	€ 180,50	1	024240077
TV77	€ 18,50	1	024000474

T79

6



80 8x9-10x11-12x13
14x15-16x17
18x19 mm

1,3 kg



T79	€ 240,00	1	024240079
TV79	€ 18,50	1	024000490

T80

29



○ 920A 10-11-12-13-14
15-16-17-18-19
20-21-22-23-24
26-27-30-32 mm
○ 920ME
920/21 125 mm
920/22 255 mm
920/25 305 mm
920/42 305 mm
⊕ 920/55

4,1 kg

12"



T80	€ 349,00	1	024240080
TV80	€ 24,50	1	024000403

T81

29



○ 920B 10-11-12-13-14
15-16-17-18-19
20-21-22-23-24
26-27-30-32 mm
○ 920ME
920/21 125 mm
920/22 255 mm
920/25 305 mm
920/42 305 mm
⊕ 920/55

4,1 kg

12"



T81	€ 349,00	1	024240081
TV80	€ 24,50	1	024000403

T82

29



○ 920A 10-11-12-13-14
15-16-17-18-19
20-21-22-23-24
26-27-30-32 mm
○ 920ME
920AN/125 125 mm
920AN/250 250 mm
920/25 305 mm
920/42 305 mm
⊕ 920/55

4,1 kg

12"



T82	€ 360,00	1	024240082
TV80	€ 24,50	1	024000403

T83

24



○ 920A 10-11-12-13-14
15-16-17-18-19
20-21-22-23-24
26-27-30-32 mm
920/21 125 mm
920/22 255 mm
920/25 305 mm
920/42 305 mm
⊕ 920/55

3,6 kg

12"



T83	€ 274,00	1	024240083
TV83	€ 24,50	1	024000402

T85

81



● 861LP 0,5x3 - 0,6x4,5 - 0,8x5,5 - 1x5,5 - 1,2x6,5 - 1,2x8 - 1,6x8 mm
○ 861PE 2 - 2,5 - 3 - 4 - 5 - 6 - 8 - 10 mm
⊕ 861PH PH0 - PH1 - PH2 - PH3
⊕ 861PZ PZ1 - PZ2 - PZ3
⊕ 861TX T6-T7-T8-T9-T10-T15-T20-T25-T27-T30-T40
⊕ 861RTX T9-T10-T15-T20-T25-T27-T30-T40
● 861TRW 1-2-3-4-5-6 mm
⊕ 861TQS 0-1-2-3-4-5-6-8 mm
⊕ 861SP 4-6-8-10-12 mm
851SR 230 mm
○ 900 4-4,5-5-5,5-6-7-8-9
10-11-12-13-14 mm
900/21 150 mm
900/25 41 mm
900BG/30 176 mm
900/42 115 mm
⊕ 900/55 125 mm
194 1/4x5/16

1,0 kg

14"



T85	€ 286,00	1	024240085
TV85	€ 24,50	1	024000747

T91

25



○ 900 4-4,5-5-5,5-6
7-8-9-10-11
12-13-14 mm
○ 900ME 2,5-3-4-5-6-8 mm
900/20 50 mm
900/21 150 mm
900/25 150 mm
900BG/30 115 mm
900/42 115 mm
⊕ 900/55

560 g

14"



T91	€ 190,00	1	024240091
TV90	€ 18,50	1	024000447

T92

22



○ 910A 6-7-8-9-10-11-12-13
14-15-16-17-18-19
20-21-22 mm
910/21 125 mm
910/22 250 mm
910/25 210 mm
910/42 210 mm
⊕ 910/55

1,5 kg

38"



T92	€ 215,50	1	024240092
TV92	€ 18,50	1	024000458

T99



- 920INOX-A 10-12-13-14-15-16-17
18-19-21-22-24-27
30-32mm
- 920/55INOX



2,7 kg

12"

T99	€ 942,00	1	024240099
TV99	€ 18,50	1	024249908

T100



- 920A 10-12-13-14-15
16-17-18-19-21
22-24 mm
- 920/21 125 mm
- 920/25 305 mm
- 920/42 305 mm
- 920/55

2,1 kg

12"

T100	€ 195,50	1	024240100
TV100	€ 18,50	1	024000495

T101



- 920B 10-12-13-14-15
16-17-18-19-21
22-24 mm
- 920/21 125 mm
- 920/25 305 mm
- 920/42 305 mm
- 920/55

2,1 kg

12"

T101	€ 195,50	1	024240101
TV100	€ 18,50	1	024000495

T102



- 920AS 3/8-7/16-1/2
9/16-5/8-11/16
3/4-13/16-7/8
15/16-1-1.1/16
- 920/21 125 mm
- 920/25 305 mm
- 920/42 305 mm
- 920/55

2,1 kg

12"

T102	€ 213,50	1	024240102
TV100	€ 18,50	1	024000495

T103



- 900L 6-7-8-9-10-11-12 mm
- 920AL 13-14-16-17-18-19
21-22-24-27 mm

1,1 kg

14" 12"

T103	€ 251,00	1	024240103
TV103	€ 18,50	1	024000748

T105



- 928A 22-24-27-30-32-34
36-38-41-46-50 mm

4,9 kg

3/4"

T105	€ 255,00	1	024240105
TV105	€ 18,50	1	024000484

T106



- 928/21 200 mm
- 928/22 380 mm
- 928/42 450 mm
- 928/55

4,5 kg

3/4"

T106	€ 266,00	1	024240106
TV106	€ 18,50	1	024000485

T110



- 720 10-11-12-13-14
16-17-18-19-21
22-23-24 mm
- 720/21 125 mm

1,8 kg

12"

T110	€ 164,50	1	024240110
TV110	€ 18,50	1	024000477

T112



- 861TX ● 1/4-T6+T15
- 866TX ● 5/16-T20+T55
- 895/1 ○ 1/4x□1/4
- 895/6 ○ 5/16x□1/2
- 900FTX □ 1/4-E4+E10
- 920FTX □ 1/2-E12+E24
- 920TX □ 1/2-T55L-T60-T70L

1,3 kg

14" 12"

T112	€ 250,00	1	024240112
TV112	€ 18,50	1	024000480

T113



- 920PE 5L-6L-7L-8L-10L
- 920TX T40L-T45L
T55L-T70L
- 920XZN M6L-M8L-M12L

1,5 kg

12"

T113	€ 224,00	1	024240113
TV113	€ 18,50	1	024000489

T121



- 666N/20 40 - 200 Nm

1,4 kg

12"

T121	€ 235,50	1	024240121
TV121	€ 18,50	1	024000767

T137



- 1084BM 160 mm
- 1150BM 180 mm
- 1166BM 160 mm

750 g

T137	€ 92,00	1	024240137
TV130	€ 18,50	1	024000451

T135



- ◄ 1082MQ 160 mm
- ≡ 1150MQ 180 mm
- 1166MQ 160 mm

⚡ 1000 V

📦 750 g



T135	€ 137,00	1	024240135
TV135	€ 18,50	1	024000762

T136



- 1048MQ 250 mm
- 1777MQ/U

📦 700 g



T136	€ 98,50	1	024240136
TV136	€ 18,50	1	024000438

T138



- ◄ 1084 160 mm
- ≡ 1150 180 mm
- 1166 160 mm

📦 650 g



T138	€ 75,50	1	024240138
TV130	€ 18,50	1	024000451

T140



- 1032 140x0,9 - 180 mm
- 1034 170 mm
- 1036 140x1,3 - 175 mm
- 1038 175 mm
- ◄ 1084 160 mm
- 1128BM

📦 1,1 kg



T140	€ 188,50	1	024240140
TV140	€ 24,50	1	024000405

T144



- 1048 250 mm
- 1052 240 mm
- 1112 250 mm
- ≡ 1150 180 mm

📦 1,8 kg



T144	€ 115,00	1	024240144
TV143	€ 24,50	1	024000409

T145



- 1032 180 mm
- 1034 170 mm
- 1036 175 mm
- 1038 175 mm

📦 640 g



T145	€ 103,50	1	024240145
TV145	€ 18,50	1	024000448

T146



- 1032 140x0,9 mm
- 1032 225 mm
- 1036 140x1,3 mm
- 1036 225 mm

📦 700 g



T146	€ 107,00	1	024240146
TV146	€ 18,50	1	024000449

T151



- 1047 240 mm
- 1057A 240 mm

📦 1,3 kg



T151	€ 97,00	1	024240151
TV150	€ 18,50	1	024000462

T153



- 1048 250 mm
- 1052 240 mm

📦 1,1 kg



T153	€ 63,50	1	024240153
TV150	€ 18,50	1	024000462

T156



- ◄ 1082 160 mm
- ≡ 1150 180 mm
- 1048 250 mm

📦 1 kg



T156	€ 82,00	1	024240156
TV148	€ 18,50	1	024000500

T157



- ◄ 1082BM 160 mm
- ≡ 1150BM 180 mm
- 1048BM 250 mm

📦 1,1 kg



T157	€ 105,00	1	024240157
TV148	€ 18,50	1	024000500

T160



Betamax

- 1290 3x75
- 3x100
- 4x100
- 4x150
- 5,5x100
- 5,5x150
- 6,5x150
- 8x150
- 10x200 mm
- 1290N 4x30
- 6,5x30 mm

📦 1,3 kg



T160	€ 109,50	1	024240160
TV160	€ 24,50	1	024000706

T161

Betamax



- 1292 PH0x60
PH0x100
PH1x80
PH1x120
PH2x100
PH2x150
PH3x150 mm
- 1292N PH1x30
PH2x30 mm

1 kg



T161	€ 85,00	1	024240161
TV161	€ 24,50	1	024000707

T164



- 952 8-10-13-17-19 mm
- 959 16 mm (5/8") - 20,8 mm (13/16")
- 1260 3x75-4x100-5,5x100
6,5x150-10x200 mm
- 1262 PH0x60-PH1x80
PH2x100-PH3x150 mm

5 kg



T164	€ 382,00	1	024240164
TV61	€ 37,00	1	024000721

T167



- 1260 3x75
3x100
4x100
4x150
5,5x100
5,5x150
6,5x150
8x150
10x200 mm
- 1260N 4x30
6,5x30 mm

1,3 kg



T167	€ 89,50	1	024240167
TV160	€ 24,50	1	024000706

T168



- 1262 PH0x60
PH0x100
PH1x80
PH1x120
PH2x100
PH2x150
PH3x150 mm
- 1262N PH1x30
PH2x30 mm

1 kg



T168	€ 71,00	1	024240168
TV161	€ 24,50	1	024000707

T170

Betamax



- 1290 2,5x50
3x75
3,5x100
4x125
5,5x100
5,5x150
6,5x150 mm

450 g



T170	€ 58,50	1	024240170
TV170	€ 18,50	1	024000741

T171

Betamax



- 1290 8x150
8x200
10x200 mm
- 1290N 4x30
6,5x30 mm

750 g



T171	€ 65,00	1	024240171
TV171	€ 18,50	1	024000742

T172

Betamax



- 1292 PH0x60
PH0x100
PH1x80
PH1x120
PH2x100
PH2x150 mm

450 g



T172	€ 53,50	1	024240172
TV172	€ 18,50	1	024000743

T173

Betamax



- 1292 PH3x150
PH4x200 mm
- 1292N PH1x30
PH2x30 mm

560 g



T173	€ 52,50	1	024240173
TV173	€ 18,50	1	024000744

T175

Betamax



- 1297TX T6-T7-T8-T9
T10-T15-T20

410 g



T175	€ 84,50	1	024240175
TV175	€ 18,50	1	024000760

T176

Betamax



- 1297TX T25-T27-T30
T40-T45

640 g



T176	€ 77,00	1	024240176
TV176	€ 18,50	1	024000761

T177

Betamax



- 1298RTX T9-T10-T15
T20-T25-T27
T30-T40

680 g



T177	€ 117,50	1	024240177
TV177	€ 18,50	1	024000759

Beta
Quality Tools

T180

Betamax



- 1290 3x75
4x100
5,5x150
6,5x150 mm
- ⊕ 1292 PH0x60
PH1x80
PH2x100 mm

480 g



T180	€ 61,00	1	024240180
TV180	€ 18,50	1	024000701

T183

Betamax



- ⊕ 1292L PH1x400-PH2x400 mm
- 1294L 3x300-4x400-5x400 mm

580 g



T183	€ 84,00	1	024240183
TV183	€ 18,50	1	024000497

T198



- 1260 3x75
4x100
5,5x150
6,5x150 mm
- ⊕ 1269PZ PZ0 - PZ1 - PZ2

490 g



T198	€ 53,50	1	024240198
TV180	€ 18,50	1	024000701

T199



- 1260 2,5x50
3x75
3,5x100
4x125
5,5x100
5,5x150
6,5x150 mm

490 g



T199	€ 48,00	1	024240199
TV170	€ 18,50	1	024000741

T201



- 1260 8x200
10x150
10x200 mm
- 1260N 4x30
6,5x30 mm

680 g



T201	€ 52,50	1	024240201
TV171	€ 18,50	1	024000742

T202



- ⊕ 1262 PH0x60
PH0x100
PH1x80
PH1x120
PH2x100
PH2x150 mm

490 g



T202	€ 44,00	1	024240202
TV172	€ 18,50	1	024000743

T204



- ⊕ 1262 PH3x150
PH4x200 mm
- ⊕ 1262N PH1x30
PH2x30 mm

610 g



T204	€ 43,50	1	024240204
TV173	€ 18,50	1	024000744

T205



- ⊕ 1267TX T6-T7-T8-T9
T10-T15-T20

460 g



T205	€ 63,00	1	024240205
TV175	€ 18,50	1	024000760

T206



- ⊕ 1267TX T25-T27-T30
T40-T45

710 g



T206	€ 64,50	1	024240206
TV176	€ 18,50	1	024000761

T207



- ⊕ 1268RTX T9-T10-T15
T20-T25-T27-T30

760 g



T207	€ 77,00	1	024240207
TV207	€ 18,50	1	024000758

T208



- 1260 3x75
4x100
5,5x150
6,5x150 mm
- ⊕ 1262 PH0x60
PH1x80
PH2x100 mm

530 g



T208	€ 50,50	1	024240208
TV180	€ 18,50	1	024000701

T209



- ⊕ 1262L PH1x400-PH2x400 mm
- 1264L 3x300-4x400-5x400 mm

580 g



T209	€ 63,00	1	024240209
TV183	€ 18,50	1	024000497

T211



- 1201E 2,5x50
3x75
3,5x100
4x125
5,5x100
5,5x150
6,5x150 mm

490 g



T211	€ 35,00	1	024240211
TV170	€ 18,50	1	024000741

T213



- 1202E PH0x60
PH1x80
PH1x120
PH2x100
PH2x150
PH3x150 mm

490 g



T213	€ 38,00	1	024240213
TV212	€ 18,50	1	024000440

T216



- 1207E/TX T6-T7-T8-T9
T10-T15-T20

410 g



T216	€ 48,50	1	024240216
TV175	€ 18,50	1	024000760

T221



- 1201E 3x75
4x100
5,5x150
6,5x150 mm
- 1202E PH0x60
PH1x80
PH2x100 mm

530 g



T221	€ 37,00	1	024240221
TV180	€ 18,50	1	024000701

T226

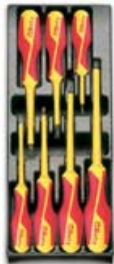

- 1274MQ 3x100
4x100
5,5x125
6,5x150 mm
- 1272MQ PH0x60
PH1x80
PH2x100 mm

⚡ 1000 V

460 g



T226	€ 78,50	1	024240226
TV180	€ 18,50	1	024000701

T227



- 944BX 5-6-7-8-10-13 mm

490 g



T227	€ 115,00	1	024240227
TV227	€ 18,50	1	024000705

T228



- 1290INOX 3x75 - 4x100 -
5,5x150 - 6,5x150 mm
- 1292INOX PH0x60 - PH1x80 -
PH2x100 mm



480 g



T228	€ 70,00	1	024240228
TV180	€ 18,50	1	024000701

T231



- 1370 400 g
- 1390 Ø 35 mm
- ▲ 1719BMA/T 200 mm
- 1719BMA/P 200 mm
- 1719BMA/M 200 mm

1,7 kg



T231	€ 96,00	1	024240231
TV230	€ 24,50	1	024000411

T233



- 35 100-200 mm
- 1370F 32 mm
- 1390 Ø 35 mm

1,3 kg



T233	€ 88,50	1	024240233
TV232	€ 18,50	1	024000452

T234



- 35 100-200 mm
- 1370 300 g
- 1390 Ø 35 mm

1,3 kg



T234	€ 78,50	1	024240234
TV232	€ 18,50	1	024000452

T236



- 1719BMA/Q 200 mm
- ▲ 1719BMA/T 200 mm
- 1719BMA/P 200 mm
- 1719BMA/M 200 mm
- 1719BMA/R 200 mm

870 g



T236	€ 78,00	1	024240236
TV235	€ 18,50	1	024000453

T239



- 31BM Ø 2-3-4-5-6-8 mm
- 32 Ø 4 mm

850 g



T239	€ 105,00	1	024240239
TV239	€ 18,50	1	024000439

T241

3



1500N/1
1500N/3
1516/1

4,2 kg

T241	€ 242,00	1	024240241
TV241	€ 24,50	1	024000414

T250

Automotive

8



34 150 mm
83/S3 11x13-14x17
19x22 mm
1458 175 mm
1491
1603
1708/13 0,05÷1 mm

1430 g

T250	€ 215,00	1	024240250
TV250	€ 24,50	1	024000408

T256

Automotive

8



○ 956E 16 mm (5/8) - 20,8 mm (13/16)
○ 956L 16 mm (5/8) - 20,8 mm (13/16)
959 16 mm (5/8) - 20,8 mm (13/16)
= 1164 200 mm
1708/20 0,05÷1 mm

3,2 kg

T256	€ 337,00	1	024240256
TV255	€ 31,00	1	024000467

Beta

Quality Tools

T259

40



○ 96BP 2,5-3-4-5
6-8-10 mm
○ 96N 12 mm
● 860MIX/A31
○
⊕
⊕
⊕
895/1

950 g

T259	€ 123,00	1	024240259
TV263	€ 18,50	1	024000492

T264

16



1491 Ø 65÷110 mm
■ 1494 ■ 10 mm
○ 1494E ○ 8-9-10-11-12-14-17 mm
○ 1494Q ○ 8-9,5-12-13 mm
△ 1494T △ 9,5
○ 1494XZN ○ 16
1496C ■ 8x ■ 10 mm

2,1 kg

T264	€ 183,50	1	024240264
TV264	€ 18,50	1	024000466

T270

60



430 M3 - 4 - 5 - 6 - 7 - 8 - 9
10 - 12 - 14 - 16 - 18 - 20
433 M6x0,75 - M8x1 - M10x1,25
M12x1,5 - M14x1,5
M16x1,5 - M18x1,5
440 M3 - 4 - 5 - 6 - 7 - 8 - 9
440A M10 - 12 - 14 - 16 - 18 - 20
441 M6x0,75 - M8x1,0
441A M10x1,25 - M12x1,5
M14x1,5 - M16x1,5
M18x1,5

4,3 kg

T270	€ 425,00	1	024240270
TV270	€ 24,50	1	024000481

T273

7



435/1,5 M3÷M12
435/3 M5÷M21
436/1 □ 2,0÷5,0 mm
(M3÷M8)
436/2 □ 4,6÷8 mm
(M5÷M12)
444/1 Ø 25,4 mm
444/2 Ø 38,1 mm
1707 W 62÷4x1"

2,1 kg

T273	€ 196,00	1	024240273
TV272	€ 24,50	1	024000482

T281

1



1741B 250 mm
1741RV2,9K 2,9x6 mm (100)
1741RV3,2K 3,2x8 mm (100)
1741RV3,8K 3,8x10 mm (100)
1741RV4K 4x12 mm (100)

1,4 kg

T281	€ 61,50	1	024240281
TV280	€ 18,50	1	024000478

T285

5



1112 250 mm
1128BM -
1726 400 mm
1728BM (5)
1753 200 cc

1,5 kg

T285	€ 98,00	1	024240285
TV285	€ 31,00	1	024000487

Beta

Beta

T284

10



1128BMX	
1130BMX	
1719BMA...Q	200 mm
1719BMA...T	200 mm
1719BMA...P	200 mm
1719BMA...M	200 mm
1719BMA...R	200 mm
1726BM	400 mm
1728BM	
1771BM	170 mm
1778V18	185 mm

3,3 kg



T284	€ 207,50	1	024240284
TV286	€ 37,00	1	024249904

T289

4



1692	5 m
1725CR	-
1755	30 cc
1771	-

500 g



T289	€ 39,00	1	024240289
TV290	€ 18,50	1	024000455

T291

3



1479RB/1	
1479RB/2	
1479RB/3	

600 g



T291	€ 83,00	1	024240291
TV291	€ 18,50	1	024000472

T297

3



1651DGT	
1682	
1691BM	

490 g



T297	€ 139,00	1	024240297
TV296	€ 18,50	1	024000749

VP1 - VP2

termoformati portaminuterie in materiale plastico per tutti i modelli di cassettiere: C22S, C23S, C23SC

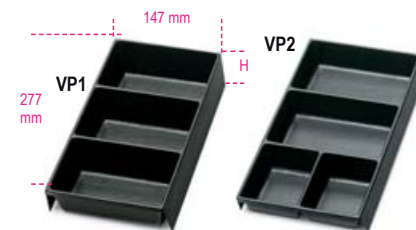

VP1	H mm 50	€ 10,70	1	088880351
VP2	H mm 35	€ 10,70	1	088880352

VP3 - VP4

termoformati portaminuterie in materiale plastico per tutti i modelli di cassettiere e per i carrelli

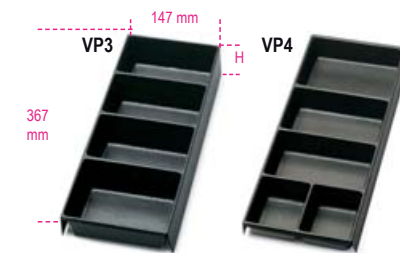

VP3	H mm 50	€ 11,20	1	088880353
VP4	H mm 35	€ 11,20	1	088880354

VP5

termoformato



VP5		€ 12,50	1	088880355
-----	--	---------	---	-----------

VP6

termoformato

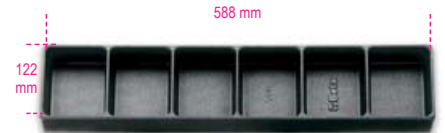

VP6		€ 12,80	1	088880359
-----	--	---------	---	-----------

VP-3SC

termoformati portaminuterie in materiale plastico per cassettiere C38 +C04TSS-7

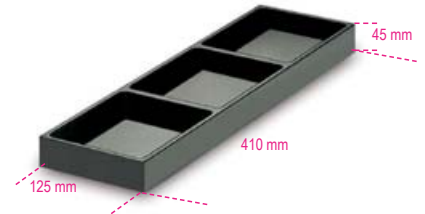

VP-3SC	H mm 45	€ 13,50	1	088880356
--------	---------	---------	---	-----------

VP-LS

termoformati portaminuterie in materiale plastico per cassettiere C38 +C04TSS-7



VP-LS	H mm 45	€ 9,20	1	088880357
-------	---------	--------	---	-----------

VP-LD

termoformati portaminuterie in materiale plastico per cassettiere C38



VP-LD	H mm 45	€ 8,80	1	088880358
-------	---------	--------	---	-----------

8889P1

separatori paralleli per C22S e C27S

cassetto 588x257 mm



8889P1/5	h mm 50	€ 35,50	1	088890005
8889P1/7	h mm 70	€ 36,50	1	088890007

8889C1

separatori incrociati per C22S e C27S

cassetto 588x257 mm



	h	€		
8889C1/5	50 mm	46,00	1	088890015
8889C1/7	70 mm	47,00	1	088890017

8889P2

separatori paralleli per cassetto standard 588x367 mm



	h	€		
8889P2/7	70 mm	43,00	1	088890107

8889C2

separatori incrociati per cassetto standard 588x367 mm



	h	€		
8889C2	70 mm	53,50	1	088890117

8889P3

separatori paralleli per C24SA-XL

cassetto 882x367 mm



	h	€		
8889P3	70 mm	68,00	1	088890207

8889C3

separatori incrociati per C24SA-XL

per cassetto 882x367 mm



	h	€		
8889C3	70 mm	83,00	1	088890217

8889P4

separatori paralleli per trolley C41

cassetto 418x205 mm



	h	€		
8889P4	70 mm	28,50	1	088890307

8889I4

separatori incrociati per trolley C41

cassetto 418x205 mm



	h	€		
8889I4	70 mm	34,00	1	088890317

8889PS

separatori paralleli per C38 +C04TSS-7

cassetto lato sinistro 570x410 mm



	h	€		
8889PS/7	70 mm	50,50	1	088890407

8889CS

separatori incrociati per C38 +C04TSS-7

cassetto lato sinistro 570x410 mm



	h	€		
8889CS/7	70 mm	61,50	1	088890417

8889PD

separatori paralleli per C38 +C04TSS-7

cassetto lato destro 313x410 mm



	h	€		
8889PD/7	70 mm	27,00	1	088890427

8889CD

separatori incrociati per C38 +C04TSS-7

cassetto lato destro 313x410 mm



	h	€		
8889CD/7	70 mm	37,00	1	088890437

8889C6

separatori incrociati per C35

cassetto 600x447 mm



	h	€		
8889C6/7,5	75 mm	26,50	1	088890475
8889C6/10	100 mm	26,00	1	088890480
8889C6/15	150 mm	32,50	1	088890485
8889C6/20	200 mm	50,00	1	088890490

SB

guide portabussole



	L	mm	€		
SB1	210		2,70	10	088880201
SB2	280		3,00	10	088880202
SB3	360		3,20	10	088880203

MB

molle per guide SB



		€		
MB0	1/4	0,80	50	088880210
MB1	3/8	0,80	50	088880211
MB2	1/2	0,80	50	088880212

KIT/GPS

Kit ganci GPS 40mm con viti VE1

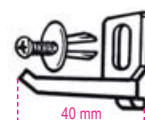

	€		
KIT/GPS	1,55	50	088880119

VE1

Viti ad espansione



	€		
VE1	0,55	20	088880120

GM

Ganci a molla con vite

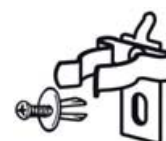

Ø	mm	€		
6,5		4,70	5	088880250
9,5		4,90	5	088880251
13		4,90	5	088880252
16		5,00	5	088880253
19		5,20	5	088880254
25		4,90	5	088880255

S55/8

Supporti chiavi a forchetta

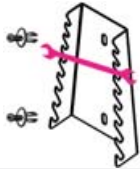

S55/8 € 17,00 1 088880420
55/S8
55AS/8
55MP/S8

S55/12

Supporti chiavi a forchetta

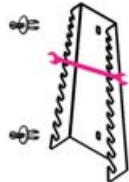

S55/12 € 21,00 1 088880421
55/S12
55/S12X
55AS/12
55MP/S12

ST2P

Tasca portapinzze

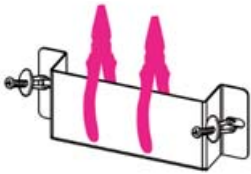

ST2P € 18,50 1 088880422

TSPP

Tasche portautensili

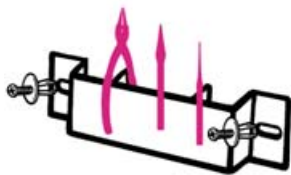

TSPP € 4,20 1 088880402

S952/10

Supporti chiavi a T

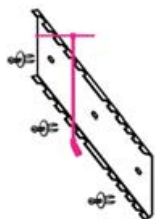

S952/10 € 22,50 1 088880423

S1719BM

Supporti per lime



S1719BM € 12,80 1 088880404
1719BMA: Q-T-P-M-R
1719BMD: Q-T-P-M-R

SGN

Supporti per giravite nano



SGN € 6,50 1 088880405
1290N-1292N-1299N/PZ
1260N-1262N-1269N/PZ
1201N-1202N-1209N/PZ

CB/2

Termoformato vuoto per bussole e accessori da 1/2"

solo per C54S

12"

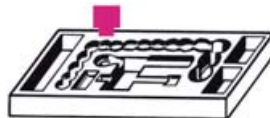

CB/2 € 19,50 1 088880411
920A/920B
10=24+26-27
28-30-32 mm
920/21-920/22-920/25-
920/42-920/55

S42/17

Supporti chiavi combinate

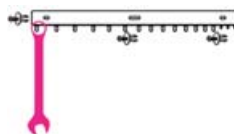

S42/17 € 22,00 1 088880428
42/S17
42MP/S17
42/S17X
42AS/17
142/S17

S951/6

Supporti chiavi a T maschio

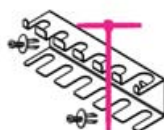

S951/6 € 14,50 1 088880429
951/S6
951AS/S6X
951TX/S6

SPG11 - S1203/8

Supporti giravite

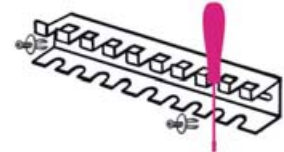

SPG11 € 15,00 1 088880910
n.8 Ø = 7 mm
n.2 Ø = 10 mm
n.1 Ø = 12 mm

S1203/8 € 16,00 1 088880430

1203/S8
1263/D8
1293/S8

S96T/8

Supporti chiavi esagonali



S96T/8 € 16,00 1 088880431

96T/SPV

Supporti per 96T e 97TTX

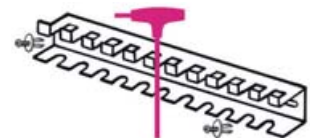

96T/SPV € 14,50 1 000960958
96T/S11
97TTX/S11

 **Beta**
Quality Tools

 **Beta**



Beta CHEMICALS

Stringere un bullone non è sempre sufficiente per ottenere un serraggio sicuro. Occorre pulirlo, lubrificarlo, sigillarlo.

La famiglia si compone di sigillanti anaerobici, adesivi cianocrilati e aerosol per la manutenzione, la pulizia e la lubrificazione dei componenti meccanici.

Prodotti anaerobici

I prodotti anaerobici garantiscono il completo riempimento delle piccole irregolarità superficiali del metallo in modo da garantire la distribuzione delle sollecitazioni meccaniche su tutta la superficie di collegamento. Si consolidano in totale assenza di ossigeno e sigillano completamente il giunto o la filettatura rispetto ad acqua, gas, olii, carburanti e fluidi industriali. Sono disponibili in tre classi di resistenza: alta (H), media (M) e bassa (L) e in differenti confezionamenti per soddisfare le differenti esigenze.

Colla istantanea

Adesivo a base di cianocrilato etilico, per giunzioni strutturali di vari materiali.

Aerosol

Ampia gamma di prodotti in bombolette spray concepiti per sbloccare, ingrassare, lubrificare, pulire, zincare e igienizzare.

Le bombolette sono in acciaio, completamente riciclabili.

Liquidi

Nascono per rimuovere incrostazioni e ruggine da pezzi meccanici e oggetti metallici. Ideali per l'impiego con le vasche di lavaggio a ultrasuoni 1895.

ATTENZIONE

Paesi in cui è possibile distribuire i prodotti della linea Beta Chemicals: Austria, Belgio, Francia, Italia, Paesi Bassi, Polonia, Portogallo, Regno Unito, Repubblica d'Irlanda, Spagna, Svizzera, Ungheria.



9803H

frenafiletti - forte resistenza

Ideale per bloccaggio permanente di parti che non devono essere smontate.

Per l'applicazione su superfici metalliche passivate come ottone, alluminio e acciaio inox.

Non consente lo smontaggio con utensili manuali.



Temperatura di impiego (°C)	-50/+150
Gioco diametrale (mm)	0,25
Velocità di reazione	10/15
blocco alla mano (minuti)	
Indurimento funzionale (ore)	3-6
Viscosità (mPa.s) 25°C	800/1200
Coppia di svitamento	35-45 Nm
INIZIALE (ISO-10964)	
Coppia di svitamento	30-40 Nm
RESIDUA (ISO-10964)	

ml	flacone	€	12	098030002
20	flacone	9,50	12	098030002
50	flacone	14,50	4	098030005
250	flacone	37,00	4	098030025

9802M

frenafiletti - media resistenza

Ideale per frenare e bloccare parti soggette a manutenzione e smontaggi periodici.

Permette lo smontaggio con l'uso di utensili manuali.



Temperatura di impiego (°C)	-50/+150
Gioco diametrale (mm)	0,15
Velocità di reazione	10/15
blocco alla mano (minuti)	
Indurimento funzionale (ore)	3-6
Viscosità (mPa.s) 25°C	500/800
Coppia di svitamento	22-30 Nm
INIZIALE (ISO-10964)	
Coppia di svitamento	20-25 Nm
RESIDUA (ISO-10964)	

ml	flacone	€	12	098020002
20	flacone	9,50	12	098020002
50	flacone	14,50	4	098020005
250	flacone	37,00	4	098020025



9801L

frenafiletti - bassa resistenza

Ideale per frenare particolari in leghe leggere che potrebbero danneggiarsi in fase di smontaggio o per viti di regolazione.

Permette uno smontaggio facile delle parti assemblate.



Temperatura di impiego (°C)	-50/+150
Gioco diametrale (mm)	0,10
Velocità di reazione	10/15
blocco alla mano (minuti)	
Indurimento funzionale (ore)	3-6
Viscosità (mPa.s) 25°C	500/800
Coppia di svitamento	6-10 Nm
INIZIALE (ISO-10964)	
Coppia di svitamento	4-8 Nm
RESIDUA (ISO-10964)	

ml	flacone	€	12	098010002
20	flacone	9,50	12	098010002
50	flacone	14,50	4	098010005
250	flacone	37,00	4	098010025

9813H

sigillaraccordi - forte resistenza

Ideale per sigillatura permanente di raccordi filettati che non devono essere smontati.

Per l'applicazione su superfici metalliche passivate come ottone, alluminio e acciaio inox.

Non consente lo smontaggio con utensili manuali.



Temperatura (°C)	-50/+200
Gioco diametrale (mm)	0,15
Velocità di reazione	10/15
blocco alla mano (minuti)	
Indurimento funzionale (ore)	3-6
Viscosità (mPa.s) 25°C	40.000/80.000
Coppia di svitamento	35-45 Nm
INIZIALE (ISO-10964)	
Coppia di svitamento	25-35 Nm
RESIDUA (ISO-10964)	

ml	flacone	€	12	098130002
20	flacone	8,50	12	098130002
50	soffietto	15,00	6	098130305
50	tubo	14,00	4	098130505
100	tubo	24,50	4	098130510
250	tubo	34,50	4	098130525

9812M

sigillaraccordi - media resistenza

Ideale per sigillare raccordi filettati soggetti a manutenzione periodica.

Permette lo smontaggio con l'uso di utensili manuali.



Temperatura (°C)	-50/+150
Gioco diametrale (mm)	0,35
Velocità di reazione	12/18
blocco alla mano (minuti)	
Indurimento funzionale (ore)	3-6
Viscosità (mPa.s) 25°C	20.000/40.000
Coppia di svitamento	27-35 Nm
INIZIALE (ISO-10964)	
Coppia di svitamento	20-30 Nm
RESIDUA (ISO-10964)	

ml	flacone	€	12	098120002
20	flacone	8,50	12	098120002
50	soffietto	15,00	6	098120305
50	tubo	14,00	4	098120505
100	tubo	24,50	4	098120510
250	tubo	34,50	4	098120525

9811L

sigillaraccordi - bassa resistenza

Ideale per sigillare raccordi piccoli o a passo fine.

Permette uno smontaggio facile delle parti assemblate.



Temperatura (°C)	-50/+150
Gioco diametrale (mm)	0,20
Velocità di reazione	10/15
blocco alla mano (minuti)	
Indurimento funzionale (ore)	3-6
Viscosità (mPa.s) 25°C	10.000/20.000
Coppia di svitamento	6-10 Nm
INIZIALE (ISO-10964)	
Coppia di svitamento	4-8 Nm
RESIDUA (ISO-10964)	

ml	flacone	€	12	098110002
20	flacone	8,50	12	098110002
50	soffietto	15,00	6	098110305
50	tubo	14,00	4	098110505
100	tubo	24,50	4	098110510
250	tubo	34,50	4	098110525



9823H

guarnizione liquida- alta resistenza

Ideale per sigillare superfici in modo permanente.
Ideale anche per ricostruire sedi cuscinetto o parti usurate.
Non consente lo smontaggio con utensili manuali.



Temperatura (°C)	-50/+150
Gioco diametrale (mm)	0,35
Velocità di reazione	10/16
blocco alla mano (minuti)	
Indurimento funzionale (ore)	3-6
Viscosità (mPa.s) 25°C	100.000/200.000
Coppia di svitamento	35-45 Nm
INIZIALE (ISO-10964)	
Coppia di svitamento	20-30 Nm
RESIDUA (ISO-10964)	

ml	flacone	€		
20	flacone	8,50	12	098230002
50	soffietto	15,00	6	098230305
50	tubo	14,00	4	098230505
100	tubo	24,50	4	098230510
250	tubo	34,50	4	098230525

9822M

guarnizione liquida- media resistenza

Ideale per sigillare superfici di parti soggette a manutenzione periodica.
Permette lo smontaggio con l'uso di utensili manuali.



Temperatura (°C)	-50/+150
Gioco diametrale (mm)	0,35
Velocità di reazione	10/15
blocco alla mano (minuti)	
Indurimento funzionale (ore)	3-6
Viscosità (mPa.s) 25°C	40.000/70.000
Coppia di svitamento	25-35 Nm
INIZIALE (ISO-10964)	
Coppia di svitamento	20-30 Nm
RESIDUA (ISO-10964)	

ml	flacone	€		
20	flacone	8,50	12	098220002
50	soffietto	15,00	6	098220305
50	tubo	14,00	4	098220505
100	tubo	24,50	4	098220510
250	tubo	34,50	4	098220525

Beta

Quality Tools

9821L

guarnizione liquida- bassa resistenza

Ideale per sigillare superfici di parti soggette a frequente manutenzione.

Tollerata la leggera contaminazione di olii.
Protegge le filettature da corrosione e grippaggi da corrosione.
Permette uno smontaggio facile delle parti assemblate.



Temperatura (°C)	-50/+150
Gioco diametrale (mm)	0,35
Velocità di reazione	20/30
blocco alla mano (minuti)	
Indurimento funzionale (ore)	3-6
Viscosità (mPa.s) 25°C	60.000/90.000
Coppia di svitamento	7-11 Nm
INIZIALE (ISO-10964)	
Coppia di svitamento	4-9 Nm
RESIDUA (ISO-10964)	

ml	flacone	€		
20	flacone	8,50	12	098210002
50	soffietto	15,00	6	098210305
50	tubo	14,00	4	098210505
100	tubo	24,50	4	098210510
250	tubo	34,50	4	098210525

9833H

bloccante - alta resistenza

Ideale per fissaggio di parti che non devono essere smontate.
Adatto fissare dispositivi già installati dove risulta difficoltoso lo smontaggio.
Non consente lo smontaggio con utensili manuali.



Temperatura (°C)	-50/+180
Gioco diametrale (mm)	0,15
Velocità di reazione	10/15
blocco alla mano (minuti)	
Indurimento funzionale (ore)	3-6
Viscosità (mPa.s) 25°C	400/700
Coppia di svitamento	35-45 Nm
INIZIALE (ISO-10964)	
Coppia di svitamento	30-40 Nm
RESIDUA (ISO-10964)	

ml	flacone	€		
20	flacone	9,00	12	098330002
50	flacone	14,00	4	098330005
250	flacone	36,00	4	098330025

9832M

bloccante - media resistenza

Ideale per fissaggio di parti soggette a manutenzione periodica.
Permette lo smontaggio con l'uso di utensili manuali.



Temperatura (°C)	-50/+180
Gioco diametrale (mm)	0,25
Velocità di reazione	12/20
blocco alla mano (minuti)	
Indurimento funzionale (ore)	3-6
Viscosità (mPa.s) 25°C	2000/4000
Coppia di svitamento	25-35 Nm
INIZIALE (ISO-10964)	
Coppia di svitamento	18-28 Nm
RESIDUA (ISO-10964)	

ml	flacone	€		
20	flacone	9,00	12	098320002
50	flacone	14,00	4	098320005
250	flacone	36,00	4	098320025

9831L

bloccante- bassa resistenza

Ideale per fissaggio di parti soggette a manutenzione frequente e di piccole dimensioni.
Permette uno smontaggio facile delle parti assemblate.



Temperatura (°C)	-50/+150
Gioco diametrale (mm)	0,10
Velocità di reazione	10/15
blocco alla mano (minuti)	
Indurimento funzionale (ore)	3-6
Viscosità (mPa.s) 25°C	500/800
Coppia di svitamento	6-10 Nm
INIZIALE (ISO-10964)	
Coppia di svitamento	4-8 Nm
RESIDUA (ISO-10964)	

ml	flacone	€		
20	flacone	9,00	12	098310002
50	flacone	14,00	4	098310005
250	flacone	36,00	4	098310025



9851

colla istantanea
per giunzioni strutturali
istantanee

A base di cianoacrilato etilico.

Consente l'adesione di una vasta gamma di materiali come metallo, plastiche, cuoio, legno ed altri svariati tipi di substrato anche in combinazione tra loro.
Velocità di presa Alta.



Temperatura (°C) -55/+82
Viscosità (mPa.s) 25°C 80-120

g	flacone	€	12	098510002
20	flacone	9,00	12	098510002
50	flacone	17,50	10	098510005
500	flacone	144,00	1	098510050

9710 - LUBRIBETA universal

sbloccante lubrificante multiuso 7 funzioni

1. Sbloccante;
 2. Lubrificante;
 3. Detergente;
 4. Protettivo antiruggine;
 5. Disossidante per contatti elettrici;
 6. Idrorepellente;
 7. Anticongelante.
- Non contiene silicone.



ml	€	12	097100040
400	7,60	12	097100040
400		12	0971101040

9712 - Ultra Sblock

sbloccante, super-penetrante

Sbloccante, disossidante e idrorepellente
Ideale per sciogliere la ruggine da dadi, bulloni, viti e ingranaggi.



ml	€	12	097120040
400	5,50	12	097120040
400		12	097121040

9720 - Multi Grease

grasso lubrificante spray multiuso

Particolarmente indicato per la lubrificazione di catene, ingranaggi e parti metalliche in movimento.
Resiste agli attriti e agli agenti atmosferici.
Altamente adesivo. Non cola.



ml	€	12	097200040
400	6,30	12	097200040
400		12	097201040

9722 - Lithium Grease

grasso bianco spray al litio

A base di grassi saponificati di litio, titanio e ossidi di zinco.
Ideale per ingranaggi, cuscinetti e giunti. Specifico per applicazioni marine.
Fortemente resistente ad acqua, salsedine, agenti atmosferici e alte temperature.
Non cola.



ml	€	12	097220040
400	7,10	12	097220040
400		12	097221040

9724 - PTFE Grease

grasso spray a base di P.T.F.E.

Particolarmente indicato per lubrificazione di catene industriali e movimenti meccanici a forti pressione e rotazioni non elevate.
Adatto per applicazioni su plastica e gomma.
Totalmente incolore. Idrorepellente e resistente all'ossidazione.



ml	€	12	097240040
400	8,10	12	097240040
400		12	097241040

9726 - Copper Grease

grasso spray al rame micronizzato

Per lubrificazione di giunti, bulloni, ingranaggi, alberi motore e altre parti metalliche soggette ad elevate temperature (fino a 1.000° C).
Protettivo, anti-usura. Previene l'ossidazione. Non cola.



ml	€	12	097260040
400	9,50	12	097260040
400		12	097261040

9729 - Silic Spray

silicone spray

Adatto per la lubrificazione dei parti in plastica, gomma e metalli.
Protegge dalla corrosione. Distaccante. Antistatico.
Idrorepellente.
Lucidante per legno, plastica e gomma. Non contiene solventi.



ml	€	12	097290040
400	5,50	12	097290040
400		12	097291040

9738 - Cutting Oil

olio da taglio

Ad alto potere lubrificante e protettivo.
Indicato per fresatura, alesatura, filettatura, foratura e lavorazioni per macchine manuali e automatiche.
Elevata resistenza all'ossidazione.
Lavabile con acqua. Non contiene solventi.



ml	€	12	097380040
400	6,00	12	097380040
400		12	097381040

9740 - Brake Cleaner

pulitore per freni

Ideale per la pulizia di dischi e pastiglie freno, motori. Elimina grasso e catrame, senza lasciare residui. Ad evaporazione rapida. Non intacca gomma e plastica.



ml	€		
500	5,40	12	097400050
500		12	097401050

9741 - Multi Cleaner

detergente, sgrassante multiuso

Detergente e sgrassante per sciogliere grasso, olio, catrame, silicone e colla.

Adatto per pulizia di superfici in metallo, plastica rigida, ceramica, acciaio e alluminio.

Non lascia residui oleosi.



ml	€		
400	5,90	12	097410040
400		12	097411040

9742 - Contact Cleaner

pulitore per contatti elettrici ed elettronici

Elimina unto e sporco, senza lasciare residui oleosi.

Ad evaporazione rapida. Non intacca plastica e gomma.



ml	€		
400	5,90	12	097420040
400		12	097421040

9743 - SURFACE CLEANER

detergente schiumogeno

Detergente schiumogeno per tutti i tipi di superfici, utensili e tessuti.

A base di sali quaternari di ammonio, crea una schiuma attiva che pulisce e rimuove sporco e unto.

Rimuove i cattivi odori. Non serve risciacquo. Non è un disinfettante.



ml	€		
500	11,40	12	097430050
500		12	097431050

9744 - ULTRA CLEANER

detergente a base alcool

Detergente secco per utensili, superfici dure, tessuti e ambienti. A base alcool (>70%), pulisce e rimuove sporco e unto. Rimuove i cattivi odori. Non lascia residui. Evaporazione rapida. Non è un disinfettante



ml	€		
400	12,50	12	097440040
400		12	097441040

9745 - Carb Cleaner

pulitore per carburatori e corpi farfallati

Specifico per la pulizia interna ed esterna di carburatori, condotti di aspirazione e corpi farfallati.

Elimina totalmente i residui carboniosi, depositi e impurità. Non lascia residui oleosi.



ml	€		
400	7,90	12	097450040
400		12	097451040

9752 - Zinc 98%

zinco chiaro

Con elevato potere coprente, è ideale per zincare parti in ferro.

Fortemente adesivo, crea un film elastico di colore molto chiaro, simile alla zincatura a caldo.

Particolarmente resistente a ossidazione, abrasione e agenti atmosferici.

Può essere sovra-verniciato. Non cola.



ml	€		
400	6,90	12	097520040
400		12	097521040

9881U

detergente industriale alcalino per vasca ultrasuoni.

Detergente industriale alcalino, concentrato, a base acqua. Per pulizia ad ultrasuoni e altri processi di purificazione. Consente una pulizia accurata ed efficace di parti di ricambio e pezzi metallici in genere (iniettori, carburatori, valvole, ecc.). Rimuove oli, grassi, lubrificanti, residui di colla, resine, cere. Adatto anche per la pulizia di parti in alluminio.



Lt	€		
1	29,00	1	098810010

9882R

liquido distaccante selettivo di ruggine.

Liquido distaccante selettivo di ruggine a base acqua per ferro, acciaio, acciaio inox, ghisa e cromature.

Rimuove lo strato ossidato, senza danneggiare il substrato metallico.

Diluzione: da puro a max 1:1.

Temperatura minima di utilizzo: 15°C.

Tempi utilizzo: 30' - 24/48h (per ruggine consistente).

Biodegradabile e 100% idrosolubile.



Lt	€		
1	35,00	1	098820010

Una gamma completa di abrasivi rigidi e flessibili, composta da più di 500 referenze prodotte interamente in Italia. Nata e sviluppata per soddisfare ogni esigenza industriale e professionale di taglio o asportazione di materiale. Con il progetto Beta Abrasives, Beta Utensili afferma la sua volontà di offrire una gamma di prodotti completa e un servizio tecnico assoluto ai professionisti del mercato, garantito dalle competenze produttive apportate da AbraBeta.

DISCHI RIGIDI da taglio e da sbavo



I dischi rigidi rappresentano la categoria più importante di questa nuova famiglia di prodotti, per questo motivo Beta Utensili ha posto la massima attenzione nella scelta dei materiali utilizzati e delle tipologie adottate.

I dischi da taglio e sbavo sono gli strumenti più rapidi e polivalenti per la lavorazione di un'ampia varietà di materiali, mediante l'utilizzo degli utensili più indicati, siano essi smerigliatrici angolari o macchine stazionarie.

FORME dei dischi



T42

disco da taglio con centro depresso

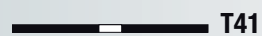

T41

disco da taglio con centro piano



T27

disco da sbavo con centro depresso



La qualità senza compromessi: destinati ad utilizzatori estremamente esigenti.



Alta qualità per grandi prestazioni, con un prezzo competitivo, per il miglior rapporto qualità/prezzo.

CERTIFICAZIONI



PITTOGRAMMI presenti sui dischi



Usare occhiali protettivi



Usare guanti protettivi



Usare cuffie antirumore



Usare abbigliamento protettivo



Usare maschera antipolvere



Consultare il manuale d'istruzioni



Disco solo per taglio – non adatto per sbavare



Non usare il disco se danneggiato



Esente da ferro, zolfo e cloro ($\leq 0,1\%$)

Validità del prodotto

La validità dei dischi è di 3 anni a partire dalla data di produzione. La dicitura "V01" incisa sulla rondella metallica al centro del disco indica il trimestre di scadenza. Esempio: la dicitura "V07/2022" indica che il disco è stato prodotto nel 3° trimestre 2019 e può essere utilizzata fino alla fine del 3° trimestre 2022.



	Trimestre
V01	Gen-Mar
V04	Apr-Giu
V07	Lug-Set
V10	Ott-Dic



MOLE CON GAMBO

Mole abrasive con gambo per utilizzo con smerigliatrici assiali. Realizzate in varie forme per adattarsi alle differenti lavorazioni e con tre tipologie di abrasivo.



RUOTE CON GAMBO

Le ruote lamellari con gambo sono prodotte con lamelle flessibili per ottenere finiture precise ed omogenee su forme e superfici irregolari.



DISCHI LAMELLARI

I dischi lamellari sono composti da lamelle di tela abrasiva incollate ad un supporto; sono un'ottima scelta per operazioni di sgrossatura e di finitura. In generale, rispetto ai dischi da sbavo, garantiscono un'asportazione più veloce, finitura più omogenea, minori vibrazioni, meno rumore e temperature di lavoro inferiori. Sono disponibili con tele di vari materiali abrasivi con differenti granulometrie e due tipi diversi di supporto.

Esecuzioni



Profilo piano

Si utilizza con un angolo massimo di 15° rispetto al piano di lavoro e permette la lavorazione di superfici piane e spigoli.



Profilo conico

Semplifica le operazioni su superfici accidentate e si utilizza con un angolo tra i 15° e i 25° rispetto al piano di lavoro. Assicura una maggiore superficie di contatto tra il disco e la superficie di lavorazione. Le lamelle possono essere utilizzate fino al loro completo esaurimento.



La qualità senza compromessi: destinati ad utilizzatori estremamente esigenti.



Alta qualità per grandi prestazioni, con un prezzo competitivo, per il miglior rapporto qualità/prezzo.



RUOTE CON FORO

Le ruote lamellari su flangia sono prodotti idonei per la lavorazione di bordi, contorni e superfici irregolari grazie all'elevata flessibilità delle lamelle.



RUOTE PER SATINATRICI

Le ruote (o rulli) per satinatrici Beta rappresentano la soluzione migliore per la finitura di qualsiasi materiale.

Gradi di grana/finitura

C	Grossolana (Coarse)
M	Media (Medium)
F	Fine (Fine)
VF	Molto fine (Very Fine)
UF	Ultra fine



DISCHI RADIALI E DISCHI FIBRATI

Dischi speciali in tessuto non tessuto (TNT) con elevate capacità di lucidatura che permettono lavorazioni veloci e precise.



ROTOLI ANTISPRECO

Un'ampia offerta di rotoli antispreco di tela e carta abrasiva e di tessuto non tessuto, di ottima qualità per gli utilizzi più vari.

Per qualsiasi ulteriore informazione si prega di fare riferimento al catalogo dedicato disponibile sul sito Beta:
www.beta-tools.com

11001

dischi abrasivi da taglio per acciaio
esecuzione a centro depresso

A30S EN 12413



A30S

	Ø mm	S mm	F mm	max. rpm	€		
11001	115	3,2	22,23	13300	1,22	10	110010118
11001	125	3,2	22,23	12200	1,35	10	110010128
11001	230	3,2	22,23	6600	2,69	10	110010233

11001H

dischi abrasivi da taglio per acciaio
esecuzione a centro depresso

come 11001 versione rigida - HARD

A30T EN 12413



A30T

	Ø mm	S mm	F mm	max. rpm	€		
11001H	230	3,2	22,23	6600	2,69	10	110010733

11003

dischi abrasivi da taglio per acciaio
esecuzione a centro piano

A30T EN 12413



A30T

	Ø mm	S mm	F mm	max. rpm	€		
11003	115	2,5	22,23	13300	1,17	10	110030117
11003	125	2,5	22,23	12200	1,22	10	110030127
11003	180	2,5	22,23	8500	1,93	10	110030182
11003	230	2,5	22,23	6600	2,64	10	110030232

11011

dischi abrasivi da sbavo per acciaio
esecuzione a centro depresso

A24N EN 12413



A24N

	Ø mm	S mm	F mm	max. rpm	€		
11011	115	6,5	22,23	13300	1,60	10	110110115
11011	125	6,5	22,23	12200	1,73	10	110110125
11011	180	6,5	22,23	8500	3,25	10	110110180
11011	230	6,5	22,23	6600	4,35	10	110110230

11011H

dischi abrasivi da sbavo per acciaio
esecuzione a centro depresso

come 11011 versione rigida - HARD

A24R EN 12413



A24R

	Ø mm	S mm	F mm	max. rpm	€		
11011H	115	6,5	22,23	13300	1,60	10	110110615
11011H	125	6,5	22,23	12200	1,73	10	110110625
11011H	180	6,5	22,23	8500	3,25	10	110110680
11011H	230	6,5	22,23	6600	4,35	10	110110730

11018

dischi abrasivi per troncatura acciaio
esecuzione a centro piano

velocità max. 60 m/s

A46N EN 12413

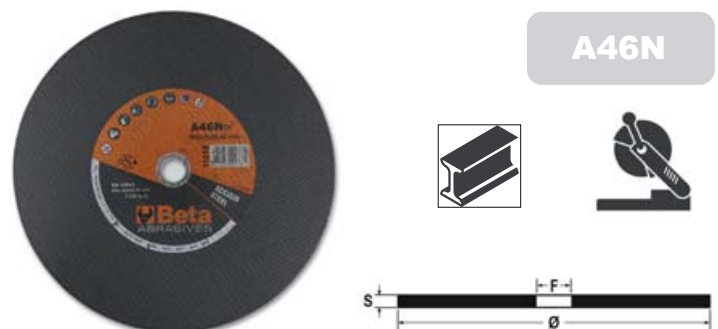

A46N

	Ø mm	S mm	F mm	max. rpm	€		
11018	300	2,5	25,40	4010	4,25	10	110180030
11018	350	3,0	25,40	3440	7,15	10	110180035
11018	400	3,2	25,40	3010	8,40	10	110180040

11019

dischi abrasivi per troncare **acciaio**
esecuzione a **centro piano**

velocità max. 80 m/s

A24N EN 12413



A24N



	Ø	S	F	max.	€	📦	🖨️
	mm	mm	mm	rpm			
11019	300	3,8	25,40	5100	4,70	10	110190030
11019	350	4,2	25,40	4400	7,40	10	110190035
11019	400	4,5	25,40	3800	9,60	10	110190040

11021

dischi abrasivi da taglio per **acciaio e inox**
esecuzione a **centro depresso**

A30Q EN 12413



A30Q

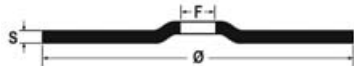

	Ø	S	F	max.	€	📦	🖨️
	mm	mm	mm	rpm			
11021	115	3,2	22,23	13300	1,25	10	110210118
11021	125	3,2	22,23	12200	1,37	10	110210128
11021	180	3,2	22,23	8500	2,13	10	110210183
11021	230	3,2	22,23	6600	2,77	10	110210233

11023

dischi abrasivi da sbavo per **acciaio e inox**
esecuzione a **centro depresso**

A24Q EN 12413



A24Q



	Ø	S	F	max.	€	📦	🖨️
	mm	mm	mm	rpm			
11023	115	6,5	22,23	13300	1,65	10	110230115
11023	125	6,5	22,23	12200	1,78	10	110230125
11023	230	6,5	22,23	6600	4,50	10	110230230

11024

dischi abrasivi da taglio per **acciaio e inox**
esecuzione di **spessore sottile** e a **centro depresso**

TOP LINE

A46U EN 12413



TOP
LINE

A46U

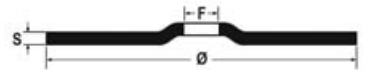

	Ø	S	F	max.	€	📦	🖨️
	mm	mm	mm	rpm			
11024	230	2,0	22,23	6600	2,74	10	110240230

11031÷11038

dischi abrasivi da taglio per **acciaio e inox**
esecuzione di **spessore sottile** e a **centro piano**

TOP LINE

A46U EN 12413



TOP
LINE

A46U



	Ø	S	F	max.	€	📦	🖨️
	mm	mm	mm	rpm			
11031	65	1,0	6,00	24000	0,94	25	110310006
11031	65	1,0	10,00	24000	0,94	25	110310010
11031	65	1,6	10,00	24000	0,94	25	110310020

	Ø	S	F	max.	€	📦	🖨️
	mm	mm	mm	rpm			
11032	76	1,0	6,00	20200	0,94	25	110320006
11032	76	1,0	10,00	20200	0,94	25	110320010
11032	76	1,6	10,00	20200	0,94	25	110320020

	Ø	S	F	max.	€	📦	🖨️
	mm	mm	mm	rpm			
11034	115	1,0	22,23	13300	1,39	25	110340022
11034	115	1,2	22,23	13300	1,39	25	110340042
11034	115	1,6	22,23	13300	1,39	25	110340062

	Ø	S	F	max.	€	📦	🖨️
	mm	mm	mm	rpm			
11035	125	1,0	22,23	12200	1,50	25	110350022
11035	125	1,2	22,23	12200	1,50	25	110350042
11035	125	1,6	22,23	12200	1,50	25	110350062

	Ø	S	F	max.	€	📦	🖨️
	mm	mm	mm	rpm			
11037	180	2,0	22,23	8500	2,40	10	110370022

	Ø	S	F	max.	€	📦	🖨️
	mm	mm	mm	rpm			
11038	230	2,0	22,23	6600	2,75	10	110380022

11040

dischi abrasivi da taglio per acciaio e inox
esecuzione di spessore sottile e a centro depresso

PREMIUM LINE

A36Q EN 12413



A36Q



	Ø	S	F	max.	€		
11040	mm	mm	mm	rpm			
	230	2,0	22,23	6600	2,75	10	110400230

11045-11046

dischi abrasivi da taglio per acciaio e inox
esecuzione di spessore sottile e a centro piano

PREMIUM LINE

A46Q EN 12413



A46Q

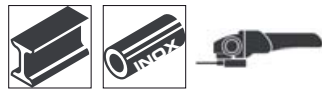

	Ø	S	F	max.	€		
11045	mm	mm	mm	rpm			
	115	1,0	22,23	13300	1,27	25	110450010
	115	1,2	22,23	13300	1,27	25	110450012
	115	1,6	22,23	13300	1,27	25	110450016

	Ø	S	F	max.	€		
11046	mm	mm	mm	rpm			
	125	1,0	22,23	12200	1,35	25	110460010
	125	1,2	22,23	12200	1,35	25	110460012
	125	1,6	22,23	12200	1,35	25	110460016

11048-11049

dischi abrasivi da taglio per acciaio e inox
esecuzione di spessore sottile e a centro piano

PREMIUM LINE

A36Q EN 12413



A36Q

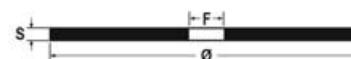

	Ø	S	F	max.	€		
11048	mm	mm	mm	rpm			
	180	2,0	22,23	8500	2,19	10	110480019

	Ø	S	F	max.	€		
11049	mm	mm	mm	rpm			
	230	2,0	22,23	6600	2,54	10	110490019

11050

dischi abrasivi da sbavo per acciaio e ghisa
esecuzione allo zirconio e a centro depresso

ZA24R - EN 12413



ZA24R



	Ø	S	F	max.	€		
11050	mm	mm	mm	rpm			
	115	6,5	22,23	13300	2,54	10	110500115
	125	6,5	22,23	12200	2,85	10	110500125
	180	7,0	22,23	8500	5,60	10	110500180
	230	7,0	22,23	6600	8,90	10	110500230

11069

dischi abrasivi da taglio per pietra e marmo
esecuzione a centro depresso

C30S EN 12413



C30S



	Ø	S	F	max.	€		
11069	mm	mm	mm	rpm			
	115	3,2	22,23	13300	1,35	10	110690115
	125	3,2	22,23	12200	1,47	10	110690125
	230	3,2	22,23	6600	2,97	10	110690230



11100

mole abrasive con gambo
granuli abrasivi di corindone rosa
forma cilindrica

gambo Ø 3 x 37 mm

EN 12413

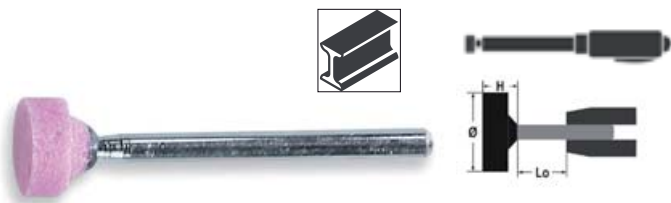

	Ø mm	h mm	max. rpm Lo=13 mm		€		
11100	4	8	130.000	AR60P5V	0,74	25	111000004
11100	6	10	93.100	AR60P5V	0,74	25	111000006
11100	8	12	64.500	AR60P5V	0,74	25	111000008
11100	10	10	60.100	AR60P5V	0,74	25	111000011
11100	10	12	52.700	AR60P5V	0,74	25	111000012
11100	12	15	37.300	AR60P5V	0,81	25	111000013

11101

mole abrasive con gambo
granuli abrasivi di corindone rosa
forma cilindrica

gambo Ø 6 x 40 mm

EN 12413

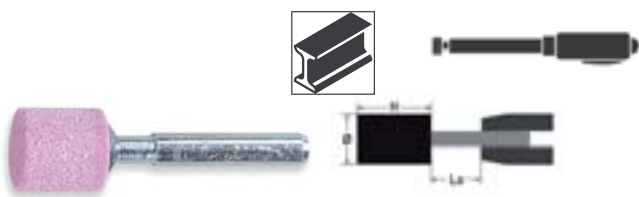

	Ø mm	h mm	max. rpm Lo=13 mm		€		
11101	4	8	130.000	AR60P5V	0,86	25	111010004
11101	5	10	130.000	AR60P5V	0,86	25	111010005
11101	6	10	130.000	AR60P5V	0,86	25	111010006
11101	8	10	119.300	AR60P5V	0,86	25	111010008
11101	10	10	95.400	AR60P5V	0,86	25	111010010
11101	10	15	95.400	AR60P5V	0,86	25	111010011
11101	10	20	86.600	AR60P5V	0,94	25	111010012
11101	10	25	72.700	AR60P5V	1,04	25	111010013
11101	10	32	58.700	AR60P5V	1,09	25	111010014
11101	12	10	79.500	AR60P5V	0,79	25	111010015
11101	12	15	79.500	AR60P5V	0,81	25	111010016
11101	12	20	79.500	AR60P5V	0,89	25	111010017
11101	15	3	63.600	AR60P5V	0,79	25	111010018
11101	15	15	63.600	AR60P5V	0,86	25	111010019
11101	16	20	59.600	AR46P5V	0,97	25	111010020
11101	16	25	56.900	AR46P5V	1,04	25	111010021
11101	16	32	45.100	AR46P5V	1,17	25	111010022
11101	20	4	47.700	AR60P5V	0,79	25	111010023
11101	20	15	47.700	AR46P5V	0,86	25	111010024
11101	20	20	47.700	AR46P5V	1,04	25	111010025
11101	20	25	46.100	AR46P5V	1,09	25	111010026
11101	20	30	38.900	AR46P5V	1,19	25	111010027
11101	20	40	29.000	AR46P5V	1,50	25	111010028
11101	25	10	38.100	AR60P5V	0,86	25	111010030
11101	25	25	37.200	AR36/46P5V	1,19	25	111010031
11101	25	40	23.300	AR36/46P5V	1,75	10	111010032
11101	30	10	31.800	AR60P5V	0,97	25	111010034
11101	30	30	26.200	AR36/46P5V	1,42	25	111010035
11101	30	40	19.500	AR36/46P5V	1,91	10	111010036
11101	32	20	29.800	AR36P5V	1,35	25	111010037
11101	32	32	23.100	AR36P5V	1,83	10	111010038
11101	40	10	23.800	AR36/46P5V	1,42	25	111010041
11101	40	20	23.800	AR36P5V	1,91	10	111010042
11101	40	25	23.400	AR36P5V	2,01	10	111010043
11101	40	30	19.700	AR36P5V	2,19	10	111010044
11101	40	40	14.700	AR36P5V	2,67	10	111010045
11101	50	15	19.000	AR36P5V	2,13	10	111010051
11101	50	25	18.800	AR36P5V	2,54	10	111010052
11101	60	10	15.900	AR36P5V	2,36	10	111010060

11102

mole abrasive con gambo
granuli abrasivi di corindone rosa
forma cilindrica

gambo Ø 6 x 80 mm

EN 12413



	Ø mm	h mm	max. rpm Lo=13 mm		€		
11102	8	20	100.500	AR60P5V	1,12	25	111020008
11102	10	15	95.400	AR60P5V	1,07	25	111020010
11102	10	30	62.200	AR60P5V	1,30	25	111020020
11102	12	15	79.500	AR60P5V	1,09	25	111020022
11102	15	15	63.600	AR60P5V	1,17	25	111020035
11102	15	30	51.000	AR46P5V	1,45	25	111020040
11102	20	30	38.900	AR46P5V	1,47	25	111020060

11105

mole abrasive con gambo
granuli abrasivi di corindone rosa
forma cilindro triangolare

gambo Ø 6 x 40 mm

EN 12413

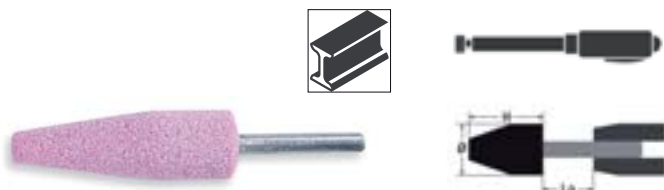

	Ø mm	h mm	max. rpm Lo=13 mm		€		
11105	20	65	16.200	AR36/46P5V	2,77	25	111050020

11106

mole abrasive con gambo
granuli abrasivi di corindone rosa
forma trapezoidale

gambo Ø 3 x 37 mm

EN 12413

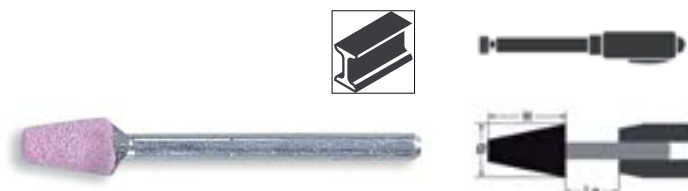

	Ø mm	h mm	max. rpm Lo=13 mm		€		
11106	6	10	93.100	AR60P5V	0,97	25	111060006

11107

mole abrasive con gambo
granuli abrasivi di corindone rosa
forma trapezoidale

gambo Ø 6 x 40 mm

EN 12413



	Ø mm	h mm	max. rpm Lo=13 mm		€		
11107	12	20	79.500	AR60P5V	1,09	25	111070012
11107	15	25	60.400	AR46P5V	1,30	25	111070015
11107	20	30	38.900	AR46P5V	1,50	25	111070020
11107	25	40	23.300	AR36/46P5V	2,19	10	111070025

11110

mole abrasive con gambo
granuli abrasivi di corindone rosa
forma conica arrotondata

gambo Ø 3 x 37 mm

EN 12413

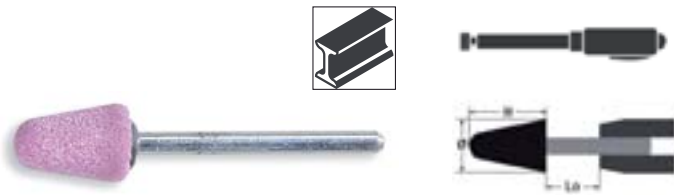

	Ø mm	h mm	max. rpm Lo=13 mm		€		
11110	10	15	44.300	AR60P5V	0,97	25	111100010

11111

mole abrasive con gambo
granuli abrasivi di corindone rosa
forma conica arrotondata

gambo Ø 6 x 40 mm

EN 12413

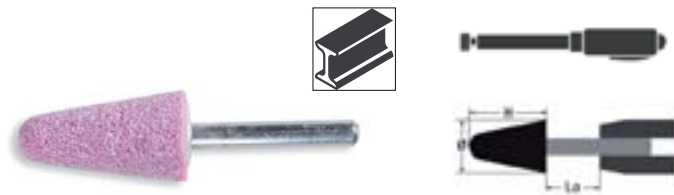

	Ø mm	h mm	max. rpm Lo=13 mm		€		
11111	10	20	86.600	AR60P5V	1,12	25	111110010
11111	15	30	51.000	AR46P5V	1,47	25	111110015
11111	16	45	31.400	AR46P5V	2,01	25	111110016
11111	20	28	41.500	AR46P5V	1,50	25	111110020
11111	20	40	29.000	AR46P5V	1,91	25	111110021
11111	30	50	15.100	AR36/46P5V	2,80	10	111110030

11115

mole abrasive con gambo
granuli abrasivi di corindone rosa
forma ad ogiva

gambo Ø 3 x 37 mm

EN 12413

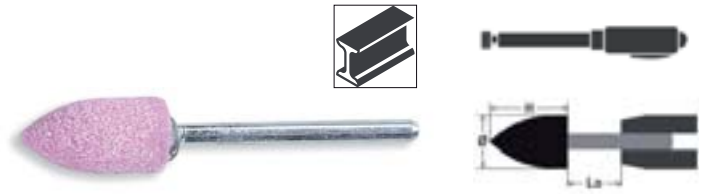

	Ø mm	h mm	max. rpm Lo=13 mm		€		
11115	10	20	34.700	AR60P5V	1,04	25	111150010

11116

mole abrasive con gambo
granuli abrasivi di corindone rosa
forma ad ogiva

gambo Ø 6 x 40 mm

EN 12413

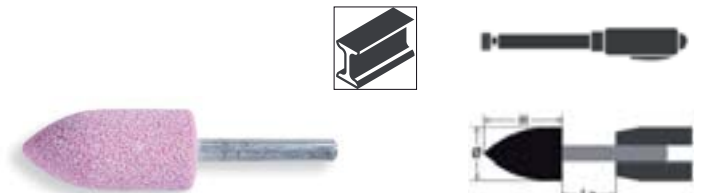

	Ø mm	h mm	max. rpm Lo=13 mm		€		
11116	10	20	86.600	AR60P5V	1,12	25	111160010
11116	18	30	43.000	AR46P5V	1,50	25	111160018
11116	20	50	22.500	AR36/46P5V	2,36	25	111160020
11116	22	70	13.400	AR36/46P5V	3,60	10	111160022

11120

mole abrasive con gambo
granuli abrasivi di corindone rosa
forma cilindro piramidale

gambo Ø 3 x 37 mm

EN 12413

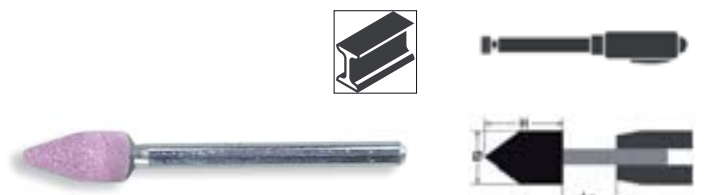

	Ø mm	h mm	max. rpm Lo=13 mm		€		
11120	6	13	77.800	AR60P5V	0,97	25	111200006

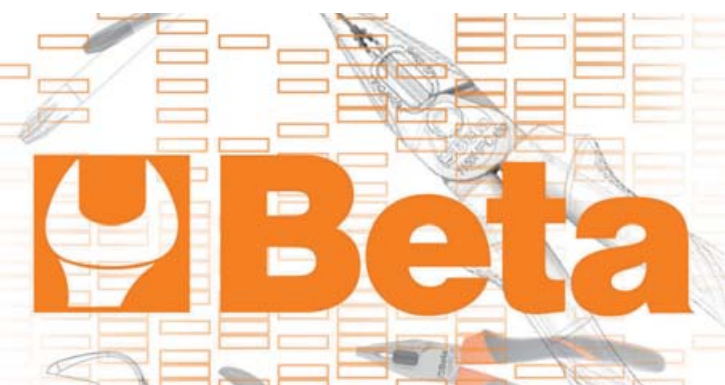

11121

mole abrasive con gambo
granuli abrasivi di corindone rosa
forma cilindro piramidale

gambo Ø 6 x 40 mm

EN 12413

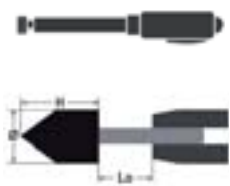

	Ø mm	h mm	max. rpm Lo=13 mm		€		
11121	6	25	100.700	AR60P5V	1,50	25	111210007
11121	12	20	79.500	AR60P5V	1,09	25	111210012
11121	20	25	46.100	AR46P5V	1,37	25	111210020
11121	25	25	37.200	AR36/46P5V	1,50	25	111210025
11121	30	30	26.200	AR36/46P5V	1,78	25	111210030

11125

mole abrasive con gambo
granuli abrasivi di corindone rosa
forma cilindro arrotondato

gambo Ø 6 x 40 mm

EN 12413

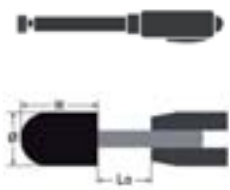

	Ø mm	h mm	max. rpm Lo=13 mm		€		
11125	6	20	117.700	AR60P5V	1,22	25	111250006
11125	25	25	37.200	AR36/46P5V	1,50	25	111250025
11125	30	50	15.100	AR36/46P5V	2,80	10	111250030
11125	40	40	14.700	AR36P5V	3,40	10	111250040

11130

mole abrasive con gambo
granuli abrasivi di corindone rosa
forma sferica

gambo Ø 3 x 37 mm

EN 12413

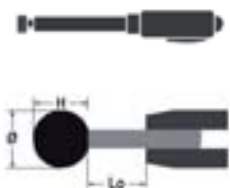

	Ø mm	h mm	max. rpm Lo=13 mm		€		
11130	6	6	124.900	AR60P5V	0,97	25	111300006
11130	8	8	84.800	AR60P5V	0,97	25	111300008
11130	10	10	60.100	AR60P5V	0,97	25	111300010

11131

mole abrasive con gambo
granuli abrasivi di corindone rosa
forma sferica

gambo Ø 6 x 40 mm

EN 12413

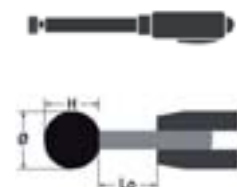

	Ø mm	h mm	max. rpm Lo=13 mm		€		
11131	10	10	95.400	AR60P5V	1,04	25	111310010
11131	15	15	63.600	AR60P5V	1,09	25	111310015
11131	20	20	47.700	AR46P5V	1,30	25	111310020
11131	25	25	37.200	AR36/46P5V	1,50	25	111310025
11131	30	30	26.200	AR36/46P5V	1,78	25	111310030

11132

mole abrasive con gambo
granuli abrasivi di corindone rosa
forma sferica

gambo Ø 6 x 80 mm

EN 12413



	Ø mm	h mm	max. rpm Lo=13 mm		€		
11132	10	10	95.400	AR60P5V	1,22	25	111320010
11132	15	15	63.600	AR60P5V	1,37	25	111320015
11132	20	20	47.700	AR46P5V	1,60	25	111320020

11135

mole abrasive con gambo
granuli abrasivi di corindone rosa
forma a disco

gambo Ø 6 x 40 mm

EN 12413



	Ø mm	h mm	max. rpm Lo=13 mm		€		
11135	30	6	31.800	AR60P5V	1,19	25	111350030
11135	40	10	23.800	AR36/46P5V	1,83	25	111350040

11140

mole abrasive con gambo
granuli abrasivi di corindone grigio/rosa
forma cilindrica

gambo Ø 6 x 40 mm

EN 12413



	Ø mm	h mm	max. rpm Lo=13 mm		€		
11140	20	30	38.900	A/AR24R5V	1,19	25	111400020
11140	25	25	37.200	A/AR24R5V	1,19	25	111400025
11140	30	30	26.200	A/AR24R5V	1,42	25	111400030
11140	50	10	19.000	A/AR24R5V	1,91	10	111400050

11141

mole abrasive con gambo
granuli abrasivi di corindone grigio/rosa
forma cilindrica

gambo Ø 8 x 40 mm

EN 12413



	Ø mm	h mm	max. rpm Lo=13 mm		€		
11141	20	40	46.800	A/AR24R5V	1,70	25	111410020
11141	30	40	31.800	A/AR24R5V	2,06	10	111410030
11141	40	40	23.800	A/AR24R5V	2,87	10	111410040

11145

mole abrasive con gambo
granuli abrasivi di corindone grigio/rosa
forma ad ogiva

gambo Ø 6 x 40 mm

EN 12413



	Ø mm	h mm	max. rpm Lo=13 mm		€		
11145	20	30	38.900	A/AR24R5V	1,50	25	111450020
11145	25	50	18.100	A/AR24R5V	2,67	10	111450025

11200A-11200B

dischi lamellari con tela abrasiva allo zirconio
supporto in plastica e lamella singola

Esecuzione piana

PREMIUM LINE

EN 13743



	Ø mm	P	F mm		€		
11200A	115	40	22,23		2,16	10	112000004
11200A	115	60	22,23		2,16	10	112000006
11200A	115	80	22,23		2,16	10	112000008
11200A	115	120	22,23		2,16	10	112000012

	Ø mm	P	F mm		€		
11200B	125	40	22,23		2,74	10	112000104
11200B	125	60	22,23		2,74	10	112000106
11200B	125	80	22,23		2,74	10	112000108

11202A-11202C

dischi lamellari con tela abrasiva allo zirconio
supporto in plastica e lamella doppia

Esecuzione piana

PREMIUM LINE

EN 13743



	Ø mm	P	F mm		€		
11202A	115	40	22,23		2,16	10	112020004
11202A	115	60	22,23		2,16	10	112020006
11202A	115	80	22,23		2,16	10	112020008
11202A	115	120	22,23		2,16	10	112020012

	Ø mm	P	F mm		€		
11202B	125	40	22,23		2,74	10	112020104
11202B	125	60	22,23		2,74	10	112020106
11202B	125	80	22,23		2,74	10	112020108

	Ø mm	P	F mm		€		
11202C	180	40	22,23		5,90	10	112020204
11202C	180	60	22,23		5,90	10	112020206

11204A÷11204C

dischi lamellari con tela abrasiva allo zirconio
supporto in fibra di vetro e lamella singola

Esecuzione piana
PREMIUM LINE
EN 13743



	Ø mm	P mm	F mm	€	📦	🖨️
11204A	115	40	22,23	2,16	10	112040004
11204A	115	60	22,23	2,16	10	112040006
11204A	115	80	22,23	2,16	10	112040008
11204A	115	120	22,23	2,16	10	112040012

	Ø mm	P mm	F mm	€	📦	🖨️
11204B	125	40	22,23	2,55	10	112040104
11204B	125	60	22,23	2,55	10	112040106
11204B	125	80	22,23	2,55	10	112040108

	Ø mm	P mm	F mm	€	📦	🖨️
11204C	180	40	22,23	5,60	10	112040204
11204C	180	60	22,23	5,60	10	112040206

11208A-11208B

dischi lamellari con tela abrasiva allo zirconio
supporto in fibra di vetro e lamella doppia

Esecuzione piana
PREMIUM LINE
EN 13743



	Ø mm	P mm	F mm	€	📦	🖨️
11208A	115	40	22,23	2,16	10	112080004
11208A	115	60	22,23	2,16	10	112080006

	Ø mm	P mm	F mm	€	📦	🖨️
11208B	125	40	22,23	2,55	10	112080104
11208B	125	60	22,23	2,55	10	112080106

11210A÷11210C

dischi lamellari con tela abrasiva allo zirconio
supporto in fibra di vetro e lamella singola

Esecuzione conica
PREMIUM LINE
EN 13743

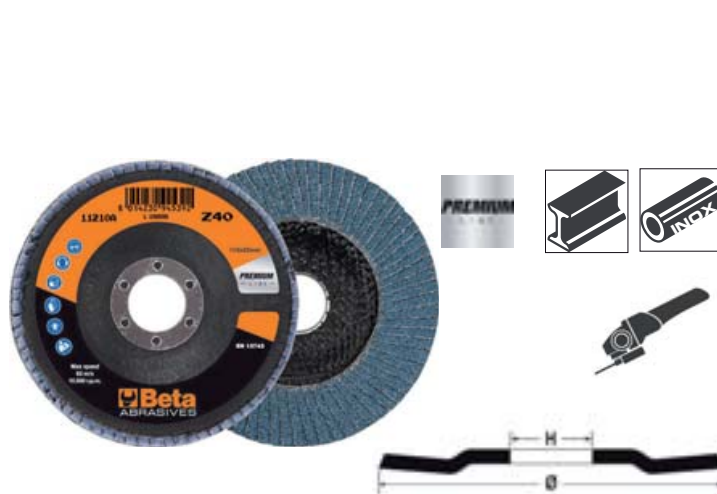

	Ø mm	P mm	F mm	€	📦	🖨️
11210A	115	40	22,23	2,16	10	112100004
11210A	115	60	22,23	2,16	10	112100006
11210A	115	80	22,23	2,16	10	112100008
11210A	115	120	22,23	2,16	10	112100012

	Ø mm	P mm	F mm	€	📦	🖨️
11210B	125	40	22,23	2,55	10	112100104
11210B	125	60	22,23	2,55	10	112100106
11210B	125	80	22,23	2,55	10	112100108

	Ø mm	P mm	F mm	€	📦	🖨️
11210C	180	40	22,23	5,60	10	112100204
11210C	180	60	22,23	5,60	10	112100206

11212A-11212B

dischi lamellari con tela abrasiva allo zirconio
supporto in plastica e lamella singola

Esecuzione piana
TOP LINE
EN 13743



	Ø mm	P mm	F mm	€	📦	🖨️
11212A	115	40	22,23	2,65	10	112120004
11212A	115	60	22,23	2,65	10	112120006
11212A	115	80	22,23	2,65	10	112120008
11212A	115	120	22,23	2,65	10	112120012

	Ø mm	P mm	F mm	€	📦	🖨️
11212B	125	40	22,23	3,45	10	112120104
11212B	125	60	22,23	3,45	10	112120106
11212B	125	80	22,23	3,45	10	112120108

11214A÷11214C

dischi lamellari con tela abrasiva allo zirconio
supporto in plastica e lamella doppia

Esecuzione piana
TOP LINE
EN 13743

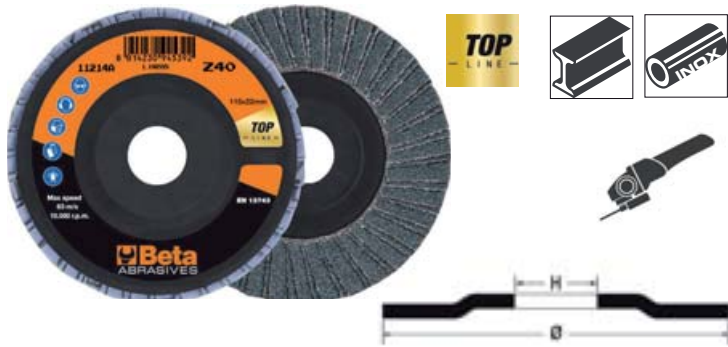

	Ø mm	P	F mm	€		
11214A	115	40	22,23	2,65	10	112140004
11214A	115	60	22,23	2,65	10	112140006
11214A	115	80	22,23	2,65	10	112140008
11214A	115	120	22,23	2,65	10	112140012

	Ø mm	P	F mm	€		
11214B	125	40	22,23	3,45	10	112140104
11214B	125	60	22,23	3,45	10	112140106
11214B	125	80	22,23	3,45	10	112140108

	Ø mm	P	F mm	€		
11214C	180	40	22,23	6,20	10	112140204
11214C	180	60	22,23	6,20	10	112140206

11216A÷11216C

dischi lamellari con tela abrasiva allo zirconio
supporto in fibra di vetro e lamella singola

Esecuzione piana
TOP LINE
EN 13743



	Ø mm	P	F mm	€		
11216A	115	40	22,23	2,65	10	112160004
11216A	115	60	22,23	2,65	10	112160006
11216A	115	80	22,23	2,65	10	112160008
11216A	115	120	22,23	2,65	10	112160012

	Ø mm	P	F mm	€		
11216B	125	40	22,23	3,15	10	112160104
11216B	125	60	22,23	3,15	10	112160106
11216B	125	80	22,23	3,15	10	112160108

	Ø mm	P	F mm	€		
11216C	180	40	22,23	5,85	10	112160204
11216C	180	60	22,23	5,85	10	112160206

11218A-11218B

dischi lamellari con tela abrasiva allo zirconio
supporto in fibra di vetro e lamella doppia

Esecuzione piana
TOP LINE
EN 13743



	Ø mm	P	F mm	€		
11218A	115	40	22,23	2,65	10	112180004
11218A	115	60	22,23	2,65	10	112180006

	Ø mm	P	F mm	€		
11218B	125	40	22,23	3,15	10	112180104
11218B	125	60	22,23	3,15	10	112180106

11220A÷11220C

dischi lamellari con tela abrasiva allo zirconio
supporto in fibra di vetro e lamella singola

Esecuzione conica
TOP LINE
EN 13743



	Ø mm	P	F mm	€		
11220A	115	40	22,23	2,65	10	112200004
11220A	115	60	22,23	2,65	10	112200006
11220A	115	80	22,23	2,65	10	112200008
11220A	115	120	22,23	2,65	10	112200012

	Ø mm	P	F mm	€		
11220B	125	40	22,23	3,15	10	112200104
11220B	125	60	22,23	3,15	10	112200106
11220B	125	80	22,23	3,15	10	112200108

	Ø mm	P	F mm	€		
11220C	180	40	22,23	5,85	10	112200204
11220C	180	60	22,23	5,85	10	112200206

11222B

dischi lamellari con tela abrasiva allo zirconio
supporto in fibra di vetro e lamella doppia

Esecuzione conica
TOP LINE
EN 13743



	Ø mm	P mm	F mm	€	10	112220104
11222B	125	40	22,23	3,15	10	112220104
11222B	125	60	22,23	3,15	10	112220106
11222B	125	80	22,23	3,15	10	112220108

11230A-11230B

dischi lamellari con tela abrasiva al corindone
supporto in plastica e lamella singola

Esecuzione piana
PREMIUM LINE
EN 13743



	Ø mm	P mm	F mm	€	10	112300004
11230A	115	40	22,23	2,16	10	112300004
11230A	115	60	22,23	2,16	10	112300006
11230A	115	80	22,23	2,16	10	112300008
11230A	115	120	22,23	2,16	10	112300012

	Ø mm	P mm	F mm	€	10	112300104
11230B	125	40	22,23	2,74	10	112300104
11230B	125	60	22,23	2,74	10	112300106

Beta

11232A

dischi lamellari con tela abrasiva al corindone
supporto in plastica e lamella doppia

Esecuzione piana
PREMIUM LINE
EN 13743



	Ø mm	P mm	F mm	€	10	112320004
11232A	115	40	22,23	2,16	10	112320004
11232A	115	60	22,23	2,16	10	112320006
11232A	115	80	22,23	2,16	10	112320008
11232A	115	120	22,23	2,16	10	112320012

11234A-11234B

dischi lamellari con tela abrasiva al corindone
supporto in fibra di vetro e lamella singola

Esecuzione piana
TOP LINE
EN 13743



	Ø mm	P mm	F mm	€	10	112340004
11234A	115	40	22,23	2,44	10	112340004
11234A	115	60	22,23	2,44	10	112340006
11234A	115	80	22,23	2,44	10	112340008
11234A	115	120	22,23	2,44	10	112340012

	Ø mm	P mm	F mm	€	10	112340104
11234B	125	40	22,23	2,89	10	112340104
11234B	125	60	22,23	2,89	10	112340106

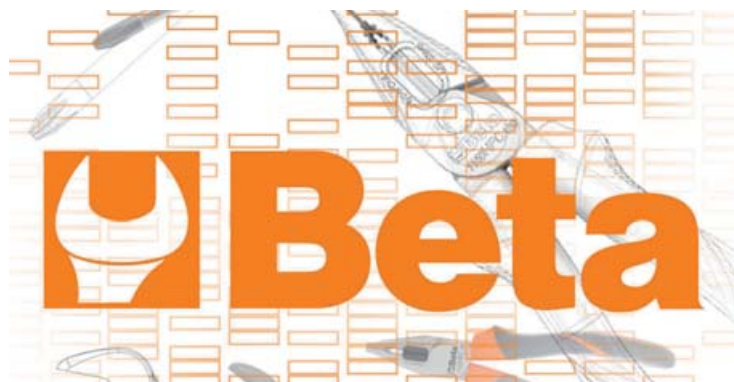

11240A-11240B

dischi lamellari con tela abrasiva allo zirconio ceramicato
supporto in plastica e lamella singola

Esecuzione piana
TOP LINE
EN 13743



	Ø mm	P	F mm	€		
11240A	115	40	22,23	3,50	10	112400004
11240A	115	60	22,23	3,50	10	112400006
	Ø mm	P	F mm	€		
11240B	125	40	22,23	4,15	10	112400104
11240B	125	60	22,23	4,15	10	112400106

11242A-11242B

dischi lamellari con tela abrasiva allo zirconio ceramicato
supporto in fibra di vetro e lamella singola

Esecuzione piana
TOP LINE
EN 13743



	Ø mm	P	F mm	€		
11242A	115	40	22,23	3,55	10	112420004
11242A	115	60	22,23	3,55	10	112420006
	Ø mm	P	F mm	€		
11242B	125	40	22,23	4,20	10	112420104
11242B	125	60	22,23	4,20	10	112420106

11246A

dischi lamellari con tela abrasiva ceramicata
supporto in plastica e lamella singola

Esecuzione piana
TOP LINE
EN 13743

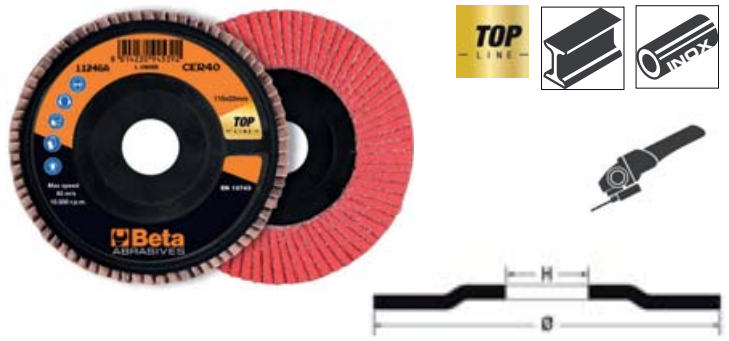

	Ø mm	P	F mm	€		
11246A	115	40	22,23	4,20	10	112460004
11246A	115	60	22,23	4,20	10	112460006

11248A-11248B

dischi lamellari con tela abrasiva ceramicata
supporto in fibra di vetro e lamella singola

Esecuzione piana
TOP LINE
EN 13743



	Ø mm	P	F mm	€		
11248A	115	40	22,23	4,25	10	112480004
11248A	115	60	22,23	4,25	10	112480006
	Ø mm	P	F mm	€		
11248B	125	40	22,23	5,45	10	112480104
11248B	125	60	22,23	5,45	10	112480106

11259

dischi lamellari con lamelle in feltro
supporto in fibra di vetro e lamella singola

Esecuzione piana
TOP LINE



	Ø mm	F mm	€		
11259	115	22,23	7,40	10	112590115
11259	125	22,23	8,50	10	112590125

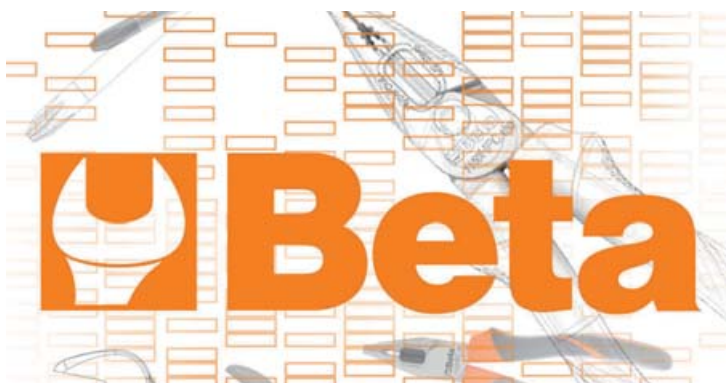

11260÷11268

ruote a lamelle con gambo
lamelle in tela abrasiva al corindone

gambo Ø 3 mm

EN 13743



	Ø mm	h mm	S mm	P	€		
11260	10	10	3	60	3,45	10	112600010
11260	15	15	3	60	2,84	10	112600015

	Ø mm	h mm	S mm	P	€		
11263	30	10	6	60	2,06	10	112630006
11263	30	15	6	60	2,06	10	112630016
11263	30	15	6	80	2,06	10	112630018
11263	30	20	6	40	2,16	10	112630024
11263	30	20	6	60	2,21	10	112630026
11263	30	20	6	80	2,21	10	112630028
11263	30	20	6	120	2,21	10	112630032

	Ø mm	h mm	S mm	P	€		
11264	40	15	6	60	2,30	10	112640006
11264	40	15	6	80	2,30	10	112640008
11264	40	15	6	120	2,30	10	112640012
11264	40	20	6	40	2,35	10	112640014
11264	40	20	6	60	2,35	10	112640016
11264	40	30	6	40	2,55	10	112640024
11264	40	30	6	60	2,55	10	112640026

	Ø mm	h mm	S mm	P	€		
11265	50	20	6	60	2,70	10	112650006
11265	50	20	6	80	2,70	10	112650008
11265	50	30	6	40	3,05	10	112650014
11265	50	30	6	60	3,05	10	112650016
11265	50	30	6	80	3,05	10	112650018
11265	50	30	6	120	3,20	10	112650022

	Ø mm	h mm	S mm	P	€		
11266	60	20	6	40	3,15	10	112660004
11266	60	20	6	60	3,15	10	112660006
11266	60	30	6	40	3,65	10	112660014
11266	60	30	6	60	3,65	10	112660016
11266	60	30	6	80	3,65	10	112660018
11266	60	30	6	120	3,80	10	112660022
11266	60	40	6	60	4,10	10	112660026
11266	60	40	6	80	4,10	10	112660028

	Ø mm	h mm	S mm	P	€		
11268	80	30	6	60	4,80	10	112680006
11268	80	30	6	80	4,80	10	112680008

Beta

11271A÷11271C

ruote in tessuto non tessuto abrasivo con gambo
tessuto in fibre sintetiche al corindone

gambo Ø 6 mm



	Ø mm	h mm	S mm	P	€		
11271A	40	20	6	C	4,80	10	112710001
11271A	40	20	6	M	4,80	10	112710002
11271A	40	20	6	F	4,80	10	112710003
11271A	40	20	6	VF	4,80	10	112710004

	Ø mm	h mm	S mm	P	€		
11271B	60	30	6	C	5,30	10	112710011
11271B	60	30	6	M	5,30	10	112710012
11271B	60	30	6	F	5,30	10	112710013
11271B	60	30	6	VF	5,30	10	112710014

	Ø mm	h mm	S mm	P	€		
11271C	80	50	6	C	5,80	10	112710021
11271C	80	50	6	M	5,80	10	112710022
11271C	80	50	6	F	5,80	10	112710023
11271C	80	50	6	VF	5,80	10	112710024

11276A÷11276C

ruote miste lamelle/tessuto non tessuto con gambo
lamelle in tela abrasiva alternata a tessuto in fibre sintetiche al corindone

gambo Ø 6 mm



	Ø mm	h mm	S mm	P	€		
11276A	40	20	6	M/60	5,30	10	112760006
11276A	40	20	6	M/80	5,30	10	112760008
11276A	40	20	6	M/120	5,30	10	112760012

	Ø mm	h mm	S mm	P	€		
11276B	60	30	6	M/60	6,30	10	112760016
11276B	60	30	6	M/80	6,30	10	112760018
11276B	60	30	6	M/120	6,30	10	112760022

	Ø mm	h mm	S mm	P	€		
11276C	80	50	6	M/60	7,70	10	112760036
11276C	80	50	6	M/80	7,70	10	112760038
11276C	80	50	6	M/120	7,70	10	112760042

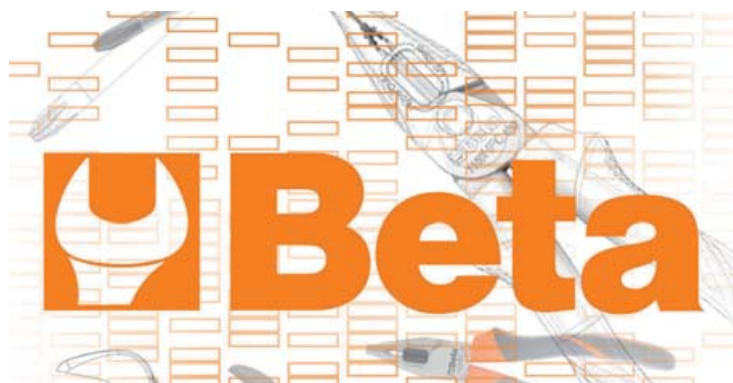

11300A÷11300G

ruote lamellari con tela al corindone con foro

EN 13743



	Ø mm	H mm	P	F mm	€		
11300A	165	30	40	54	19,10	3	113000004
11300A	165	30	60	54	19,60	3	113000006
11300A	165	30	80	54	20,00	3	113000008
11300A	165	30	120	54	21,10	3	113000012
11300A	165	30	180	54	24,00	3	113000018
11300A	165	30	220	54	25,50	3	113000022

	Ø mm	H mm	P	F mm	€		
11300B	165	50	40	54	26,00	2	113000104
11300B	165	50	60	54	27,50	2	113000106
11300B	165	50	80	54	28,50	2	113000108
11300B	165	50	120	54	30,00	2	113000112
11300B	165	50	180	54	35,00	2	113000118
11300B	165	50	220	54	37,00	2	113000122

	Ø mm	H mm	P	F mm	€		
11300C	200	30	40	54	22,10	3	113000204
11300C	200	30	60	54	24,00	3	113000206
11300C	200	30	80	54	25,50	3	113000208
11300C	200	30	120	54	26,50	3	113000212
11300C	200	30	180	54	30,00	3	113000218

	Ø mm	H mm	P	F mm	€		
11300D	200	50	40	54	31,50	2	113000304
11300D	200	50	60	54	34,00	2	113000306
11300D	200	50	80	54	36,00	2	113000308
11300D	200	50	120	54	38,00	2	113000312
11300D	200	50	180	54	44,00	2	113000318
11300D	200	50	220	54	46,00	2	113000322

	Ø mm	H mm	P	F mm	€		
11300E	250	30	40	100	40,00	3	113000404
11300E	250	30	60	100	43,00	3	113000406
11300E	250	30	80	100	44,00	3	113000408
11300E	250	30	120	100	47,00	3	113000412

	Ø mm	H mm	P	F mm	€		
11300F	250	50	40	100	59,50	2	113000504
11300F	250	50	60	100	63,50	2	113000506
11300F	250	50	80	100	65,00	2	113000508
11300F	250	50	120	100	68,00	2	113000512
11300F	250	50	180	100	75,00	2	113000518
11300F	250	50	220	100	86,00	2	113000522

	Ø mm	H mm	P	F mm	€		
11300G	300	50	40	100	83,00	2	113000604
11300G	300	50	60	100	86,00	2	113000606
11300G	300	50	80	100	89,00	2	113000608

11320

ruote in tessuto non tessuto abrasivo con foro
tessuto in fibre sintetiche al corindone

Ø 200 x 50 mm

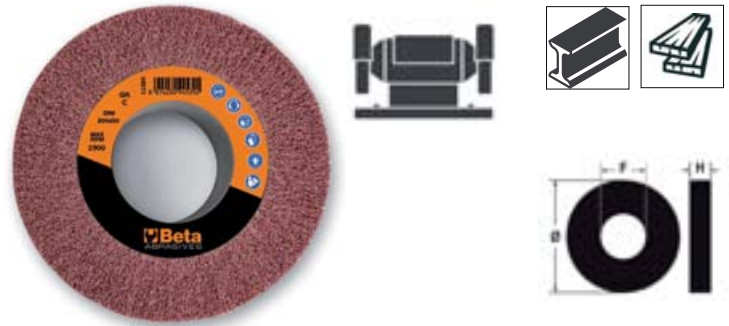

	Ø mm	H mm	P	F mm	€		
11320	200	50	C	76,2	24,00	2	113200006
11320	200	50	M	76,2	24,00	2	113200008
11320	200	50	F	76,2	24,00	2	113200012
11320	200	50	VF	76,2	24,00	2	113200024

11411

ruote lamellari con tela al corindone per satinatrici

Ø 100 x 100 mm

EN 13743

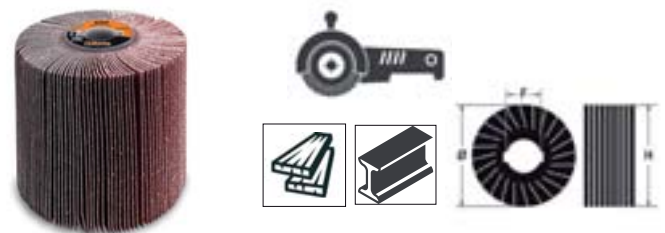

	Ø mm	H mm	P	F mm	€		
11411	100	100	40	19,1	21,10	2	114110004
11411	100	100	60	19,1	22,10	2	114110006
11411	100	100	80	19,1	22,50	2	114110008
11411	100	100	120	19,1	23,00	2	114110012
11411	100	100	240	19,1	23,50	2	114110024

11415B

ruote in tessuto non tessuto
fibre sintetiche al corindone per satinatrici

Ø 100 x 100 mm

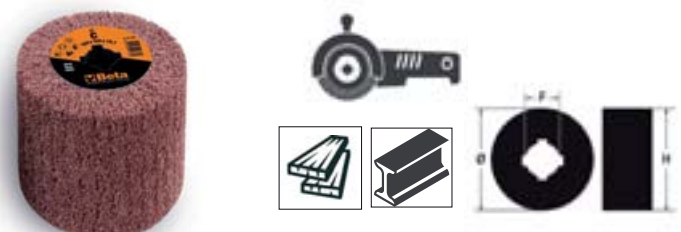

	Ø mm	H mm	P	F mm	€		
11415B	100	100	C	19,1	16,70	2	114150106
11415B	100	100	M	19,1	16,70	2	114150108
11415B	100	100	F	19,1	16,70	2	114150112
11415B	100	100	VF	19,1	16,70	2	114150124

11420B

ruote miste lamelle/tessuto non tessuto per satinatrici
tela abrasiva alternata a fibre sintetiche al corindone

Ø 100 x 100 mm

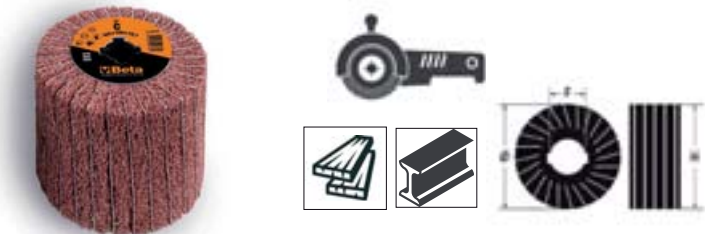

	Ø mm	H mm	P	F mm	€		
11420B	100	100	C/60	19,1	19,60	2	114200106
11420B	100	100	M/80	19,1	19,60	2	114200108
11420B	100	100	F/120	19,1	19,60	2	114200112
11420B	100	100	VF/240	19,1	19,60	2	114200124

11431

dischi radiali in tessuto non tessuto
fibre sintetiche al corindone

Ø 115 mm



	Ø mm	P	F mm	€		
11431	115	C	22,23	11,30	4	114310006
11431	115	M	22,23	11,30	4	114310008
11431	115	F	22,23	11,30	4	114310012
11431	115	VF	22,23	11,30	4	114310024

11435

dischi radiali miste lamelle/tessuto non tessuto
tela abrasiva alternata a fibre sintetiche al corindone

Ø 115 mm



	Ø mm	P	F mm	€		
11435	115	M/80	22,23	14,20	4	114350008
11435	115	M/120	22,23	14,20	4	114350012
11435	115	F/150	22,23	14,20	4	114350015
11435	115	F/180	22,23	14,20	4	114350018

11440A÷11440C

dischi fibrati con tela allo zirconio



	Ø mm	P	F mm	€		
11440A	115	24	22	0,83	25	114400024
11440A	115	36	22	0,83	25	114400036
11440A	115	60	22	0,74	25	114400060
11440A	115	120	22	0,74	25	114400120

	Ø mm	P	F mm	€		
11440B	125	24	22	0,93	25	114400224
11440B	125	36	22	0,93	25	114400236
11440B	125	60	22	0,88	25	114400260
11440B	125	120	22	0,88	25	114400320

	Ø mm	P	F mm	€		
11440C	180	24	22	1,47	25	114400424
11440C	180	36	22	1,47	25	114400436
11440C	180	60	22	1,42	25	114400460
11440C	180	120	22	1,42	25	114400520

11450A÷11450C

dischi fibrati con tela al corindone



	Ø mm	P	F mm	€		
11450A	115	24	22	0,64	25	114500024
11450A	115	36	22	0,64	25	114500036
11450A	115	60	22	0,59	25	114500060
11450A	115	120	22	0,59	25	114500120

	Ø mm	P	F mm	€		
11450B	125	24	22	0,74	25	114500224
11450B	125	36	22	0,74	25	114500236
11450B	125	60	22	0,69	25	114500260
11450B	125	120	22	0,69	25	114500320

	Ø mm	P	F mm	€		
11450C	180	24	22	1,18	25	114500424
11450C	180	36	22	1,18	25	114500436
11450C	180	60	22	1,13	25	114500460
11450C	180	120	22	1,13	25	114500520

11488PF

plattrelli di fissaggio per dischi fibrati
con ghiera M14



	∅ mm	€		
11488P	115	5,40	1	114880115
11488P	125	6,00	1	114880125
11488P	180	9,20	1	114880180

11491-11493-11495

rotoli antispreco in tela abrasiva al corindone



	H mm	L m	P	€		
11491	38	50	40	36,00	1	114910004
11491	38	50	60	35,00	1	114910006
11491	38	50	80	34,00	1	114910008
11491	38	50	100	34,00	1	114910010
11491	38	50	120	34,00	1	114910012
11491	38	50	150	34,00	1	114910015
11491	38	50	180	34,00	1	114910018
11491	38	50	220	34,00	1	114910022
11491	38	50	240	34,00	1	114910024
11491	38	50	320	34,00	1	114910032
11491	38	50	400	34,00	1	114910040

	H mm	L m	P	€		
11493	50	50	40	55,00	1	114930004
11493	50	50	60	53,00	1	114930006
11493	50	50	80	51,00	1	114930008
11493	50	50	100	49,00	1	114930010
11493	50	50	120	49,00	1	114930012
11493	50	50	150	49,00	1	114930015
11493	50	50	180	49,00	1	114930018
11493	50	50	220	49,00	1	114930022
11493	50	50	240	49,00	1	114930024
11493	50	50	320	49,00	1	114930032
11493	50	50	400	49,00	1	114930040

	H mm	L m	P	€		
11495	120	25	40	69,00	1	114950004
11495	120	25	60	67,00	1	114950006
11495	120	25	80	65,00	1	114950008
11495	120	25	100	63,50	1	114950010
11495	120	25	120	63,50	1	114950012
11495	120	25	180	63,50	1	114950018
11495	120	25	240	63,50	1	114950024
11495	120	25	400	63,50	1	114950040

11498

rotolo antispreco in tessuto non tessuto
fibre sintetiche al corindone

h 100 mm x 10 m



	H mm	L m	P	€		
11498	100	10	M	29,00	1	114980008
11498	100	10	F	22,50	1	114980012
11498	100	10	VF	22,50	1	114980015
* 11498	100	10	UF	25,50	1	114980018

*Carburo di silicio



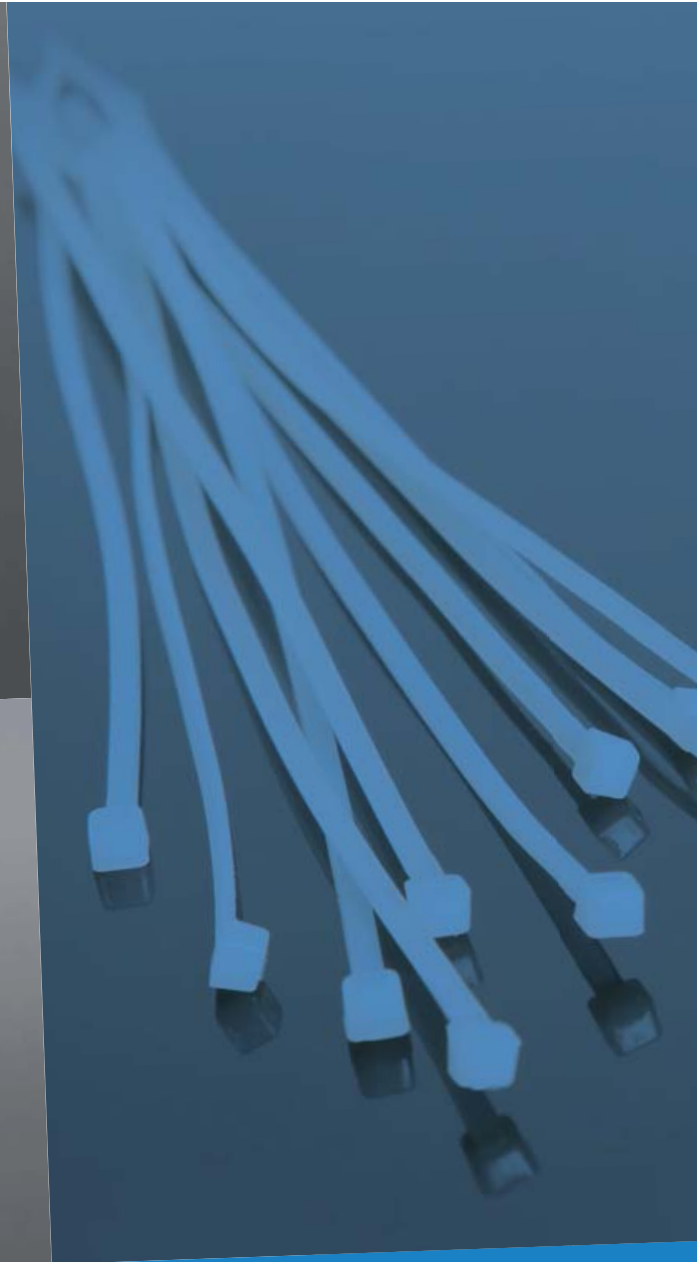
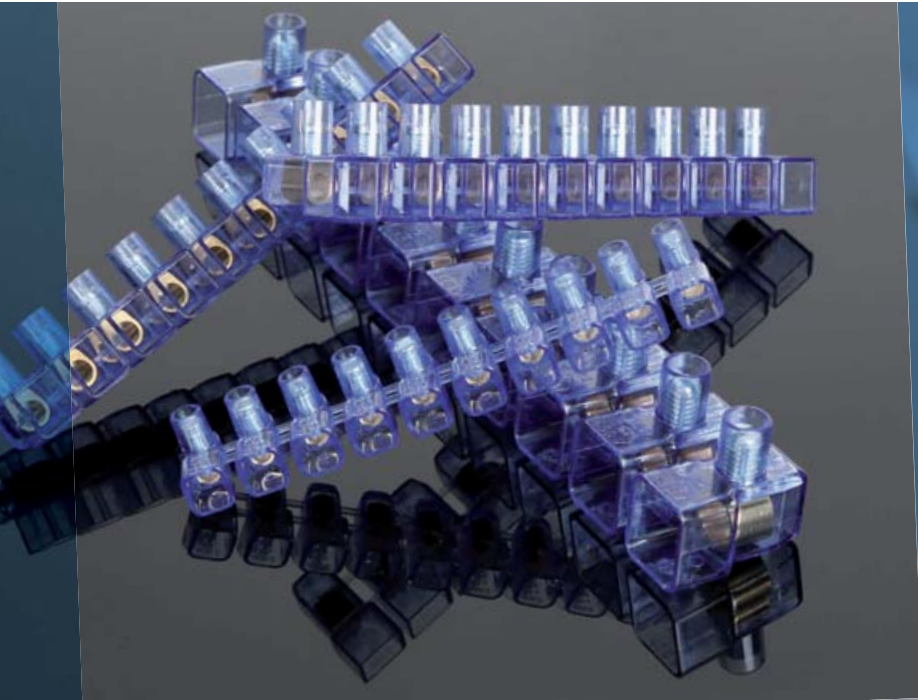

PRODOTTI A MARCHIO BM: FASCETTE, MORSETTIERE, NASTRI ISOLANTI

BM Group progetta, produce e distribuisce elementi di connessione e prodotti per l'installazione elettrica, dal 1958. Qualità, sicurezza e affidabilità sono da sempre i valori i BM, quei valori che, insieme alla passione per l'eccellenza, hanno portato l'azienda a diventare, passo dopo passo, il punto di riferimento nel mercato del materiale elettrico. Dal 2018 BM Group è parte di Beta Utensili. Un'accurata selezione di prodotti a marchio BM è presentata in questa sezione, ad integrazione della gamma Beta.

QUALITÀ CERTIFICATA





1610-B

terminali preisolati ad occhiello

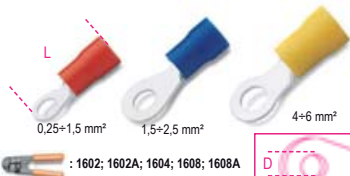

D mm	mm ²	L mm	€	100	BM
4	0,25-1,5	20,6	8,50	100	BM00119
5	0,25-1,5	21,8	9,00	100	BM00125
5	1,5-2,5	22,4	10,00	100	BM00225
6	1,5-2,5	26	12,00	100	BM00231
8	1,5-2,5	29,8	13,50	100	BM00237
6	4-6	29,1	18,50	50	BM00331
8	4-6	34,5	22,50	50	BM00337

- indicare nell'ordine il numero di terminali e non di confezioni
- i prezzi indicati sono relativi a 100 pezzi

1614-P

terminali preisolati a puntale

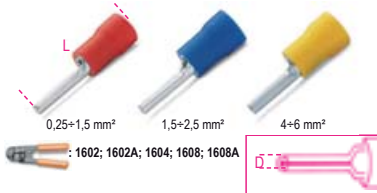

D mm	mm ²	L mm	€	100	BM
1,8	0,25-1,5	20	10,00	100	BM00151
1,8	1,5-2,5	20	11,00	100	BM00251
2,6	4-6	28	20,00	50	BM00350

- indicare nell'ordine il numero di terminali e non di confezioni
- i prezzi indicati sono relativi a 100 pezzi

1616-SM

terminali preisolati a spina maschio

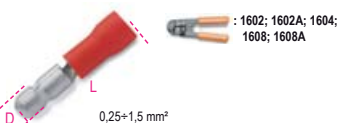

D mm	mm ²	L mm	€	100	BM
4	0,25-1,5	21	10,00	100	BM00130

- indicare nell'ordine il numero di terminali e non di confezioni
- i prezzi indicati sono relativi a 100 pezzi

1618-SF

terminali preisolati a spina femmina

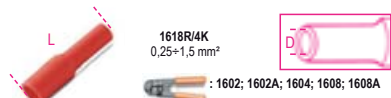

D mm	mm ²	L mm	€	100	BM
4	0,25-1,5	23,5	12,00	100	BM00140

- indicare nell'ordine il numero di terminali e non di confezioni
- i prezzi indicati sono relativi a 100 pezzi

1620-M

terminali preisolati rapidi maschio

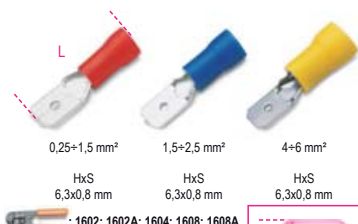

HxS mm	mm ²	L mm	€	100	BM
6,3x0,8	0,25-1,5	21	11,50	100	BM00180
6,3x0,8	1,5-2,5	21	11,50	100	BM00280
6,3x0,8	4-6	24,5	13,50	50	BM00380

- indicare nell'ordine il numero di terminali e non di confezioni
- i prezzi indicati sono relativi a 100 pezzi

1622-F

terminali preisolati rapidi femmina

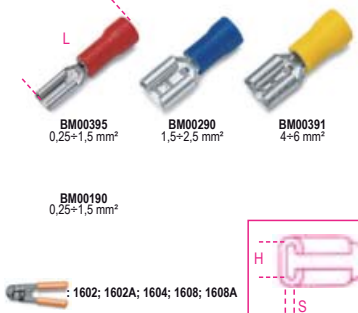

HxS mm	mm ²	L mm	€	100	BM
6,3x0,8	0,25-1,5	20,7	12,50	100	BM00190
2,8x0,5	0,25-1,5	18,5	10,50	100	BM00395
6,3x0,8	1,5-2,5	20,7	13,00	100	BM00290
6,3x0,8	4-6	24,5	14,50	50	BM00391

- indicare nell'ordine il numero di terminali e non di confezioni
- i prezzi indicati sono relativi a 100 pezzi

1624-FI

terminali rapidi femmina isolati

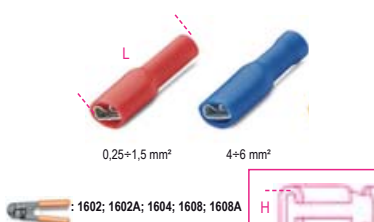

HxS mm	mm ²	L mm	€	100	BM
6,3x0,8	0,25-1,5	22	13,50	100	BM00191
6,3x0,8	1,5-2,5	22	14,00	50	BM00291
6,3x0,8	4-6	25	16,50	50	BM00392

- indicare nell'ordine il numero di terminali e non di confezioni
- i prezzi indicati sono relativi a 100 pezzi

1628-C

connettori di linea preisolati



D mm	mm ²	L mm	€	100	BM
1,8	0,25-1,5	25	10,00	100	BM00160
2,5	1,5-2,5	26,5	12,00	100	BM00260
3,7	4-6	27	16,50	50	BM00360

- indicare nell'ordine il numero di terminali e non di confezioni
- i prezzi indicati sono relativi a 100 pezzi

1630-CR

connettori rapidi



mm ²	L mm	€	500	BM
0,25-1	20	12,50	500	BM00110
1,25-2,5	20	12,50	500	BM00210

- indicare nell'ordine il numero di terminali e non di confezioni
- i prezzi indicati sono relativi a 100 pezzi

1632-TS

terminali a tubetto singoli



mm ²	L mm	€	500	BM
0,5	14	2,40	500	BM00601
0,75	14	2,40	500	BM00602
1	14	2,40	500	BM00603
1,5	14	2,40	500	BM00604
2,5	14	3,00	250	BM00506
4	17	4,50	200	BM00508
6	20	5,50	100	BM00610

- indicare nell'ordine il numero di terminali e non di confezioni
- i prezzi indicati sono relativi a 100 pezzi

1634-TD

terminali a tubetto doppi



mm ²	L mm	€	200	BM
2x0,5	15	4,20	200	BM00651
2x0,75	15	4,20	200	BM00652
2x1	15	4,20	200	BM00654
2x1,5	16	4,00	200	BM00656
2x2,5	18,5	5,00	100	BM00558
2x4	23	11,00	100	BM00560
2x6	26	17,00	50	BM00661

- indicare nell'ordine il numero di terminali e non di confezioni
- i prezzi indicati sono relativi a 100 pezzi



1635-S

morsetti di coda per connessioni volanti, barrette da 10 poli

Corpo isolante: policarbonato trasparente UL94 V0

Corpo conduttivo: ottone

Vite imperdibile: acciaio zincato

Autoestinguenza: EN60695-2-10 a 850°C, EN 60335-1:2002

+A2:2006, EN60695-2-11

Temperatura d'esercizio: max 85°C

Grado di protezione: IP20

Norme di riferimento: EN60998-1: EN60998-2-1:2004



mm ²	L mm	L1 mm	S mm	mm ²	N	€		
1.5	15	7.5	14.5	1.5	2	0,85	10	BM991
				0.75	2+4			
				1	2+3			
2.5	17.5	9	18.2	2.5	2	0,95	10	BM992
				1.5	2+3			
				1	2+4			
4	21	10.3	20	4	2	1,00	10	BM9924
				2	2+3			
				1.5	2+4			
6	22.5	11.8	23	6	2	1,35	10	BM993
				4	2+3			
				2.5	2+4			
10	26	14.7	26	10	2	2,95	10	BM994
				6	2+3			
				4	2+4			
16	31.8	18.8	32.2	16	2	5,65	10	BM995
				10	2+3			
				6	2+4			

i prezzi si riferiscono alla singola barretta

1635-S



mm ²	L mm	L1 mm	S mm	mm ²	N	€		
25	36.3	22.5	41.9	25	2	2,45	25	BM9960
				16	2+3			
				10	2+4			
35	43.5	26.1	49.4	35	2	3,05	25	BM9961
				25	2+3			
				16	2+4			



1748-BV2

fascette in nylon, colore naturale

Materiale: Poliammide PA 6.6

Classe di autoestinguenza: UL 94-V2

Temperatura di esercizio: -40°C ÷ +85°C

Temperatura minima d'installazione: -10°C

Resistenza agli agenti chimici: Buona resistenza alle basi, agli olii, ai grassi, ai solventi di cloruro. Limitata resistenza agli acidi. Non resistente ai fenoli

Norme di riferimento: EN 62275:2015-02

Classificazione: tipo 1 (EN); tipo 21 (UL)



A mm	L mm	Ø MAX mm	F MAX N	€		
2.5	80	14	80	0,72	100	BMB0824
2.5	100	20.5	80	0,80	100	BMB1025
2.5	120	27	80	1,25	100	BMB1225
2.5	160	40	80	1,55	100	BMB1625
2.5	200	52.5	80	1,85	100	BMB2025
3.6	140	33	180	1,90	100	BMB1436
3.6	200	52.5	180	2,60	100	BMB2036
3.6	300	106	180	4,00	100	BMB2936
3.6	370	105	180	5,50	100	BMB3736
4.6	120	24	220	2,30	100	BMB1248
4.6	160	36	220	2,90	100	BMB1648
4.8	188	46	220	3,35	100	BMB1948
4.8	200	50	220	3,45	100	BMB2048
4.8	250	65	220	4,65	100	BMB2548
4.8	300	81	220	5,35	100	BMB3048
4.8	370	103.5	220	6,80	100	BMB3748
4.8	390	110	220	8,20	100	BMB3948
4.8	430	122.5	220	9,70	100	BMB4348
4.8	530	160	220	12,30	100	BMB5348
7.6	150	24	550	6,20	100	BMB1576
7.6	200	51	550	8,00	100	BMB2076
7.6	300	83	550	10,50	100	BMB2976
7.6	370	103.5	550	12,50	100	BMB3776
7.6	450	130.5	550	17,20	100	BMB4576
7.6	540	159	550	23,50	100	BMB5476
7.6	750	226	550	29,50	100	BMB7576
8.8	550	163	800	25,00	100	BMB5390
8.8	710	195	800	36,00	100	BMB7190
8.8	780	235.5	800	39,50	100	BMB7890
9.0	430	130.5	800	21,50	100	BMB4390
9.0	810	245	800	43,00	100	BMB8190
9.0	1020	295	800	49,50	100	BMB1090
9.0	1220	375.5	800	70,00	100	BMB1290
9.0	1530	460	800	95,00	100	BMB1590

- indicare nell'ordine il numero di fascette e non di confezioni

- i prezzi indicati sono relativi a 100 pezzi

1748N

fascette in nylon, colore nero

UV resistant

Materiale: Poliammide PA 6.6 + carbon black

Classe di autoestinguenza: UL 94-V2

Temperatura di esercizio: -40°C ÷ +85°C

Temperatura minima d'installazione: -10°C

Resistenza agli agenti chimici: Buona resistenza alle basi, agli olii, ai grassi, ai solventi di cloruro. Limitata resistenza agli acidi. Non resistente ai fenoli

Norme di riferimento: EN 62275:2015-02

Classificazione: tipo 1 (EN)



A mm	L mm	Ø MAX mm	F MAX N	€		
2.5	80	14	80	0,72	100	BMN0824
2.5	100	20.5	80	0,80	100	BMN1025
2.5	120	27	80	1,25	100	BMN1225
2.5	160	40	80	1,55	100	BMN1625
2.5	200	52.5	80	1,85	100	BMN2025
3.6	140	33	180	1,90	100	BMN1436

A mm	L mm	Ø MAX mm	F MAX N	€		
3.6	200	52.5	180	2,60	100	BMN2036
3.6	300	106	180	4,00	100	BMN2936
3.6	370	105	180	5,50	100	BMN3736
4.6	120	24	220	2,30	100	BMN1248
4.6	160	36	220	2,90	100	BMN1648
4.8	188	46	220	3,35	100	BMN1948
4.8	200	50	220	3,45	100	BMN2048
4.8	250	65	220	4,65	100	BMN2548
4.8	300	81	220	5,35	100	BMN3048
4.8	370	103.5	220	6,80	100	BMN3748
4.8	390	110	220	8,20	100	BMN3948
4.8	430	122.5	220	9,70	100	BMN4348
4.8	530	160	220	12,30	100	BMN5348
7.6	150	24	550	6,20	100	BMN1576
7.6	200	51	550	8,00	100	BMN2076
7.6	300	83	550	10,50	100	BMN2976
7.6	370	103.5	550	12,50	100	BMN3776
7.6	450	130.5	550	17,20	100	BMN4576
7.6	540	159	550	23,50	100	BMN5476
7.6	750	226	550	29,50	100	BMN7576
8.8	550	163	800	25,00	100	BMN5390
8.8	710	195	800	36,00	100	BMN7190
8.8	780	235.5	800	39,50	100	BMN7890
9.0	430	130.5	800	21,50	100	BMN4390
9.0	810	245	800	43,00	100	BMN8190
9.0	1020	295	800	49,50	100	BMN1090
9.0	1220	375.5	800	70,00	100	BMN1290
9.0	1530	460	800	95,00	100	BMN1590

- indicare nell'ordine il numero di fascette e non di confezioni

- i prezzi indicati sono relativi a 100 pezzi

1748-UL

fascette in nylon, per carichi pesanti, colore nero

UV and IMPACT resistant

Materiale: Poliammide PA 6.6 + carbon black

Classe di autoestinguenza: UL 94-V2

Temperatura di esercizio: -40°C ÷ +85°C

Temperatura minima d'installazione: -10°C

Resistenza agli agenti chimici: Buona resistenza alle basi, agli olii, ai grassi, ai solventi di cloruro. Limitata resistenza agli acidi. Non resistente ai fenoli

Norme di riferimento: EN 62275:2015-02

Classificazione: tipo 1 (EN); tipo 21 (UL)



A mm	L mm	Ø MAX mm	F MAX N	€		
12.4	230	57	1200	22,00	100	BMN2412
12.4	480	136.5	1200	46,00	100	BMN4912
12.4	730	216.1	1200	58,00	100	BMN7412
12.4	880	263.9	1200	77,50	100	BMN8912
12.4	1000	305	1200	91,00	100	BMN1012

- indicare nell'ordine il numero di fascette e non di confezioni

- i prezzi indicati sono relativi a 100 pezzi

Beta

Beta

1748-N2D

fascette in nylon,
colore nero
UV resistant

Materiale: Poliammide PA 6.6 + carbon black
Classe di autoestinguenza: UL 94-V2
Temperatura di esercizio: -40°C ÷ +85°C
Temperatura minima d'installazione: -10°C
Resistenza agli agenti chimici: Buona resistenza alle basi, agli olii, ai grassi, ai solventi di cloruro. Limitata resistenza agli acidi. Non resistente ai fenoli
Norme di riferimento: EN 62275:2015-02
Classificazione: tipo 1 (EN)

CE



A	L	Ø MAX	F MAX	€		
mm	mm	mm	N			
9.0	180	40	400	14,00	100	BMN1890
9.0	265	62	540	24,30	100	BMN2690
9.0	360	93	540	27,00	100	BMN3690

- indicare nell'ordine il numero di fascette e non di confezioni
- i prezzi indicati sono relativi a 100 pezzi

1748-BV0

fascette in nylon autoestinguenza,
colore bianco

Materiale: Poliammide PA 6.6
Classe di autoestinguenza: UL 94-V0
Temperatura di esercizio: -40°C ÷ +85°C
Temperatura minima d'installazione: -10°C
Resistenza agli agenti chimici: Buona resistenza alle basi, agli olii, ai grassi, ai solventi di cloruro. Limitata resistenza agli acidi. Non resistente ai fenoli
Norme di riferimento: EN 62275:2015-02
Classificazione: tipo 1 (EN)

CE

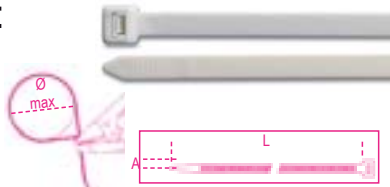

A	L	Ø MAX	F MAX	€		
mm	mm	mm	N			
2.5	100	20.5	80	1,32	100	BMB1025V0
3.6	150	36.0	180	2,95	100	BMB1536V0
3.6	200	52.5	180	4,20	100	BMB2036V0
4.8	200	49.5	230	4,60	100	BMB2048V0
4.8	300	81.0	230	7,00	100	BMB3048V0
4.8	380	106.7	230	10,10	100	BMB3848V0
7.6	380	106.7	540	17,50	100	BMB3876V0

- indicare nell'ordine il numero di fascette e non di confezioni
- i prezzi indicati sono relativi a 100 pezzi



1748-BX

fascette in nylon,
colore blu,
rilevabile da metal detector

Materiale: Poliammide PA 6.6 + polvere metallica
Classe di autoestinguenza: UL 94-V2
Temperatura di esercizio: -40°C ÷ +85°C
Temperatura minima d'installazione: -10°C
Resistenza agli agenti chimici: Buona resistenza alle basi, agli olii, ai grassi, ai solventi di cloruro. Limitata resistenza agli acidi. Non resistente ai fenoli
Norme di riferimento: EN 62275:2015-02
Classificazione: tipo 1 (EN)

CE

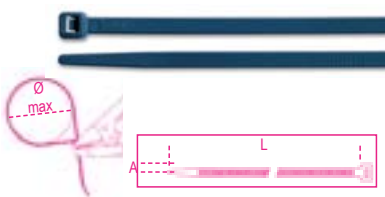

A	L	Ø MAX	F MAX	€		
mm	mm	mm	N			
2.5	100	20.5	80	1,55	100	BMBX1025
3.6	150	36.0	180	3,85	100	BMBX1536
3.6	200	52.5	180	5,05	100	BMBX2036
4.8	200	49.5	230	6,30	100	BMBX2048
4.8	300	81.0	230	9,40	100	BMBX3048
4.8	380	106.7	230	12,80	100	BMBX3848
7.6	380	106.7	540	23,10	100	BMBX3876

- indicare nell'ordine il numero di fascette e non di confezioni
- i prezzi indicati sono relativi a 100 pezzi

1748-BL

fascette in nylon con dente in acciaio,
colore naturale

Materiale: Poliammide PA 6.6 + acciaio
Classe di autoestinguenza: UL 94-V2
Temperatura di esercizio: -40°C ÷ +85°C
Temperatura minima d'installazione: -10°C
Resistenza agli agenti chimici: Buona resistenza alle basi, agli olii, ai grassi, ai solventi di cloruro. Limitata resistenza agli acidi. Non resistente ai fenoli
Norme di riferimento: EN 62275:2015-02
Classificazione: tipo 1 (EN)

CE

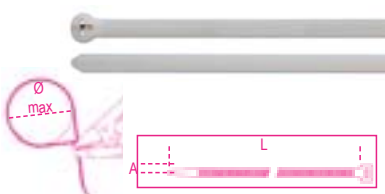

A	L	Ø MAX	F MAX	€		
mm	mm	mm	N			
2.5	100	20.5	180	2,85	100	BMBL1025
3.6	140	33.0	250	6,50	100	BMBL1436
2.5	200	52.5	180	3,75	100	BMBL2025
4.8	200	49.5	360	9,10	100	BMBL2048
4.8	300	81.0	360	12,10	100	BMBL3048
4.8	370	103.5	360	14,30	100	BMBL3748
7.6	370	103.5	780	26,00	100	BMBL3776

- indicare nell'ordine il numero di fascette e non di confezioni
- i prezzi indicati sono relativi a 100 pezzi

1748-NL

fascette in nylon con dente in acciaio,
colore nero,
UV resistant

Materiale: Poliammide PA 6.6 + acciaio + carbon black
Classe di autoestinguenza: UL 94-V2
Temperatura di esercizio: -40°C ÷ +85°C
Temperatura minima d'installazione: -10°C
Resistenza agli agenti chimici: Buona resistenza alle basi, agli olii, ai grassi, ai solventi di cloruro. Limitata resistenza agli acidi. Non resistente ai fenoli
Norme di riferimento: EN 62275:2015-02
Classificazione: tipo 1 (EN)

CE

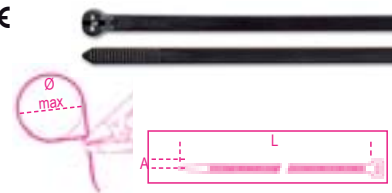

A	L	Ø MAX	F MAX	€		
mm	mm	mm	N			
2.5	100	20.5	180	2,85	100	BMNL1025
3.6	140	33.0	250	6,50	100	BMNL1436
2.5	200	52.5	180	3,75	100	BMNL2025
4.8	200	49.5	360	9,10	100	BMNL2048
4.8	300	81.0	360	12,00	100	BMNL3048
4.8	370	103.5	360	14,20	100	BMNL3748
7.6	370	103.5	780	26,00	100	BMNL3776

- indicare nell'ordine il numero di fascette e non di confezioni
- i prezzi indicati sono relativi a 100 pezzi

1748-BR

fascette in nylon riutilizzabili,
colore naturale

Materiale: Poliammide PA 6.6
Classe di autoestinguenza: UL 94-V2
Temperatura di esercizio: -40°C ÷ +85°C
Temperatura minima d'installazione: -10°C
Resistenza agli agenti chimici: Buona resistenza alle basi, agli olii, ai grassi, ai solventi di cloruro. Limitata resistenza agli acidi. Non resistente ai fenoli
Norme di riferimento: EN 62275:2015-02
Classificazione: tipo 1 (EN); tipo 21 (UL)

CE

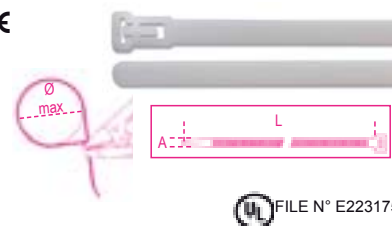

A	L	Ø MAX	F MAX	€		
mm	mm	mm	N			
7.6	150	40	230	7,50	100	BMBR1576
7.6	200	55	230	9,50	100	BMBR2076
7.6	300	82	230	14,00	100	BMBR3076

- indicare nell'ordine il numero di fascette e non di confezioni
- i prezzi indicati sono relativi a 100 pezzi



1748-BH

fascette in nylon con occhio,
colore naturale

Materiale: Poliammide PA 6.6

Classe di autoestinguenza: UL 94-V2

Temperatura di esercizio: -40°C ÷ +85°C

Temperatura minima d'installazione: -10°C

Resistenza agli agenti chimici: Buona resistenza alle basi, agli olii, ai grassi, ai solventi di cloruro. Limitata resistenza agli acidi. Non resistente ai fenoli

Norme di riferimento: EN 62275:2015-02

Classificazione: tipo 1 (EN); tipo 21 (UL)



* FILE N° E223175

A	L	Ø MAX	F MAX	€	100	BMBH1125
mm	mm	mm	N			
2.5	110	19.0	80	2,70	100	BMBH1125
* 4.8	200	49.8	230	6,55	100	BMBH2048
* 7.6	305	78.7	550	10,00	100	BMBH3076

- indicare nell'ordine il numero di fascette e non di confezioni

- i prezzi indicati sono relativi a 100 pezzi

1748-BP

fascette in nylon ad inserzione,
colore naturale

Materiale: Poliammide PA 6.6

Classe di autoestinguenza: UL 94-V2

Temperatura di esercizio: -40°C ÷ +85°C

Temperatura minima d'installazione: -10°C

Resistenza agli agenti chimici: Buona resistenza alle basi, agli olii, ai grassi, ai solventi di cloruro. Limitata resistenza agli acidi. Non resistente ai fenoli

Norme di riferimento: EN 62275:2015-02

Classificazione: tipo 1 (EN); tipo 21 (UL)



* FILE N° E223175

A	L	Ø MAX	F MAX	€	100	BMBP1536
mm	mm	mm	N			
3.6	155	37.9	180	4,00	100	BMBP1536
* 4.8	200	50.8	230	7,20	100	BMBP2048

- indicare nell'ordine il numero di fascette e non di confezioni

- i prezzi indicati sono relativi a 100 pezzi

1748-BT

fascette in nylon con targhetta trasversale
25x8mm,
colore naturale

Materiale: Poliammide PA 6.6

Classe di autoestinguenza: UL 94-V2

Temperatura di esercizio: -40°C ÷ +85°C

Temperatura minima d'installazione: -10°C

Resistenza agli agenti chimici: Buona resistenza alle basi, agli olii, ai grassi, ai solventi di cloruro. Limitata resistenza agli acidi. Non resistente ai fenoli

Norme di riferimento: EN 62275:2015-02

Classificazione: tipo 1 (EN); tipo 21 (UL)



* FILE N° E223175

A	L	Ø MAX	F MAX	€	100	BMBT21025
mm	mm	mm	N			
2.5	100	22.0	80	3,00	100	BMBT21025
2.5	200	53.5	80	4,50	100	BMBT22025

- indicare nell'ordine il numero di fascette e non di confezioni

- i prezzi indicati sono relativi a 100 pezzi

1748-BT2

fascette in nylon con targhetta longitudinale
13x27mm,
colore naturale

Materiale: Poliammide PA 6.6

Classe di autoestinguenza: UL 94-V2

Temperatura di esercizio: -40°C ÷ +85°C

Temperatura minima d'installazione: -10°C

Resistenza agli agenti chimici: Buona resistenza alle basi, agli olii, ai grassi, ai solventi di cloruro. Limitata resistenza agli acidi. Non resistente ai fenoli

Norme di riferimento: EN 62275:2015-02

Classificazione: tipo 1 (EN)



A	L	Ø MAX	F MAX	€	100	BMBT12248
mm	mm	mm	N			
4.8	190	51	230	7,00	100	BMBT12248

- indicare nell'ordine il numero di fascette e non di confezioni

- i prezzi indicati sono relativi a 100 pezzi

1748-BT3

fascette in nylon con targhetta esterna
20x9mm,
colore naturale

Materiale: Poliammide PA 6.6

Classe di autoestinguenza: UL 94-V2

Temperatura di esercizio: -40°C ÷ +85°C

Temperatura minima d'installazione: -10°C

Resistenza agli agenti chimici: Buona resistenza alle basi, agli olii, ai grassi, ai solventi di cloruro. Limitata resistenza agli acidi. Non resistente ai fenoli

Norme di riferimento: EN 62275:2015-02

Classificazione: tipo 1 (EN)

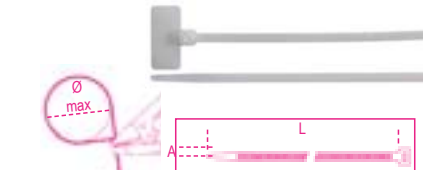

A	L	Ø MAX	F MAX	€	100	BMBT11125
mm	mm	mm	N			
2.5	110	22	80	3,60	100	BMBT11125

- indicare nell'ordine il numero di fascette e non di confezioni

- i prezzi indicati sono relativi a 100 pezzi

1748-BA1

basette di fissaggio

Materiale: Poliammide PA 6.6

Classe di autoestinguenza: UL 94-V2

Temperatura di esercizio: -40°C ÷ +85°C

Temperatura minima d'installazione: -10°C

Resistenza agli agenti chimici: Buona resistenza alle basi, agli olii, ai grassi, ai solventi di cloruro. Limitata resistenza agli acidi. Non resistente ai fenoli



SxDxH	Ø	F	€	100	BMB0905
mm	mm	mm			
15.2x9.4x6.8	3.3	3.6	4,50	100	BMB0905
22x16.2x10.8	5.2	9	10,00	100	BMB0906

- indicare nell'ordine il numero di basette e non di confezioni

- i prezzi indicati sono relativi a 100 pezzi

1748-NA1

basette di fissaggio

Materiale: Poliammide PA 6.6

Classe di autoestinguenza: UL 94-V2

Temperatura di esercizio: -40°C ÷ +85°C

Temperatura minima d'installazione: -10°C

Resistenza agli agenti chimici: Buona resistenza alle basi, agli olii, ai grassi, ai solventi di cloruro. Limitata resistenza agli acidi. Non resistente ai fenoli



SxDxH	Ø	F	€	100	BMN0905
mm	mm	mm			
15.2x9.4x6.8	3.3	3.6	4,50	100	BMN0905
22x16.2x10.8	5.2	9	8,00	100	BMN0906

- indicare nell'ordine il numero di basette e non di confezioni

- i prezzi indicati sono relativi a 100 pezzi

1748-BA2

basette di fissaggio bidirezionali

Materiale: Poliammide PA 6.6

Classe di autoestinguenza: UL 94-V2

Temperatura di esercizio: -40°C ÷ +85°C

Temperatura minima d'installazione: -10°C

Resistenza agli agenti chimici: Buona resistenza alle basi, agli olii, ai grassi, ai solventi di cloruro. Limitata resistenza agli acidi. Non resistente ai fenoli

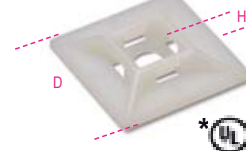

* FILE N° E223175

SxDxH	F	€	100	BMB0901
mm	mm			
19x19x5.4	3.6	6,00	100	BMB0901
* 28x28x7	4.8	11,00	100	BMB0902
* 28x28x5.8	4.8	6,80	100	BMB0903

- indicare nell'ordine il numero di basette e non di confezioni

- i prezzi indicati sono relativi a 100 pezzi

1748-NA2

basette di fissaggio bidirezionali
UV resistant

Materiale: Poliammide PA 6.6

Classe di autoestinguenza: UL 94-V2

Temperatura di esercizio: -40°C ÷ +85°C

Temperatura minima d'installazione: -10°C

Resistenza agli agenti chimici: Buona resistenza alle basi, agli olii, ai grassi, ai solventi di cloruro. Limitata resistenza agli acidi. Non resistente ai fenoli

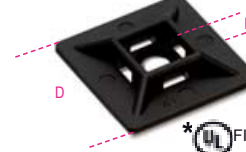

* FILE N° E223175

SxDxH	F	€	100	BMN0901
mm	mm			
19x19x5.4	3.6	5,90	100	BMN0901
* 28x28x7	4.8	11,00	100	BMN0902
* 28x28x5.8	4.8	7,50	100	BMN0903

- indicare nell'ordine il numero di basette e non di confezioni

- i prezzi indicati sono relativi a 100 pezzi

1748-S

fascette autobloccanti in acciaio inossidabile

Materiale: acciaio inox AISI 304
 Dispositivo di fissaggio: a sfera
 Classe di autoestinguenza: non infiammabile
 Plenum rating: AH-1
 Resistenza ai raggi UV: eccellente
 Temperatura di esercizio: -60°C ÷ +300°C
 Temperatura minima d'installazione: -60°C
 Resistenza agli agenti chimici: eccellente
 Norme di riferimento: EN 62275:2015-02
 Classificazione: tipo 2 (EN); tipo 2 (UL)

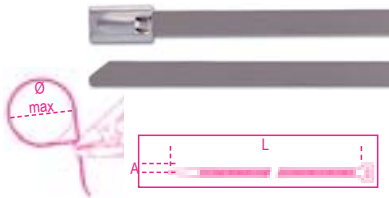

A mm	L mm	ØMAX mm	Trazione N	€		
4.6	125	38	890	29,00	100	BMS1345
4.6	200	61	890	32,00	100	BMS2045
7.9	200	61	1500	54,00	100	BMS2079
4.6	290	90	890	39,00	100	BMS3045
7.9	300	90	1500	63,50	100	BMS3079
4.6	360	112	890	44,00	100	BMS3745
7.9	360	112	1500	66,50	100	BMS3779
7.9	520	163	1500	77,50	100	BMS5079
4.6	520	163	890	50,00	100	BMS5245
4.6	680	214	890	57,50	100	BMS6845
7.9	680	214	1500	88,00	100	BMS6879
4.6	840	265	890	64,50	100	BMS8445
7.9	840	265	1500	104,00	100	BMS8479

- indicare nell'ordine il numero di fascette e non di confezioni
 - i prezzi indicati sono relativi a 100 pezzi

1748-SC

fascette autobloccanti in acciaio inossidabile ,
 rivestimento in poliestere nero

Materiale: acciaio inox AISI 304 + poliestere
 Dispositivo di fissaggio: a sfera
 Classe di autoestinguenza: non infiammabile
 Plenum rating: AH-1
 Resistenza ai raggi UV: eccellente
 Temperatura di esercizio: -60°C ÷ +300°C
 Temperatura minima d'installazione: -60°C
 Resistenza agli agenti chimici: eccellente
 Norme di riferimento: EN 62275:2015-02
 Classificazione: tipo 2 (EN); tipo 2 (UL)

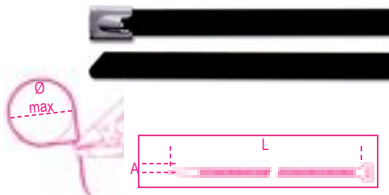

A mm	L mm	ØMAX mm	Trazione N	€		
4.6	125	38	450	24,00	100	BMSC1345
4.6	200	61	450	29,50	100	BMSC2045
7.9	200	61	800	47,50	100	BMSC2079
4.6	290	90	450	36,00	100	BMSC3045
7.9	300	90	800	57,00	100	BMSC3079
4.6	360	112	450	41,50	100	BMSC3745
7.9	360	112	800	65,00	100	BMSC3779
7.9	520	163	800	85,00	100	BMSC5079
4.6	520	163	450	53,50	100	BMSC5245
4.6	680	214	450	68,00	100	BMSC6845
7.9	680	214	800	103,00	100	BMSC6879
4.6	840	265	450	81,00	100	BMSC8445
7.9	840	265	800	122,00	100	BMSC8479

- indicare nell'ordine il numero di fascette e non di confezioni
 - i prezzi indicati sono relativi a 100 pezzi

1748-ST

pinze automatiche per fascette in acciaio inossidabile,
 per fascette da 7,6 a 9mm,
 con controllo automatico della tensione e taglio



BMS-T € 153,00 1 BM1105



1639ESB

nastro isolante in PVC

Temperatura d'esercizio: 0-90°C
 Carico di rottura: 28N/cm equivalente a 18.6 N/mm²
 Allungamento a rottura: 200%
 Adesione all'acciaio: 2.2N/cm
 Adesione al dorso: 2 N/cm
 Rigidità dielettrica: 45kV/mm
 Infiammabilità: ritardante la fiamma
 Norme di riferimento: IEC 60454-2
 Classificazione: CEI EN 60454-3-1-5/F-PVCP/90



S mm	A mm	L m	€		
0.15	15	10	0,50	10	BMESB1510BI
0.15	15	10	0,50	10	BMESB1510BL
0.15	15	10	0,50	10	BMESB1510GI
0.15	15	10	0,50	10	BMESB1510GR
0.15	15	10	0,53	10	BMESB1510GV
0.15	15	10	0,50	10	BMESB1510MA
0.15	15	10	0,50	10	BMESB1510NE
0.15	15	10	0,50	10	BMESB1510RO
0.15	15	10	0,50	10	BMESB1510VE
0.15	15	25	1,23	10	BMESB1525BI
0.15	15	25	1,23	10	BMESB1525BL
0.15	15	25	1,23	10	BMESB1525GI
0.15	15	25	1,23	10	BMESB1525GR
0.15	15	25	1,28	10	BMESB1525GV
0.15	15	25	1,23	10	BMESB1525MA
0.15	15	25	1,23	10	BMESB1525NE
0.15	15	25	1,23	10	BMESB1525RO
0.15	15	25	1,23	10	BMESB1525VE
0.15	19	25	1,49	10	BMESB1925BI
0.15	19	25	1,49	10	BMESB1925BL
0.15	19	25	1,49	10	BMESB1925GI
0.15	19	25	1,49	10	BMESB1925GR
0.15	19	25	1,54	10	BMESB1925GV
0.15	19	25	1,49	10	BMESB1925MA
0.15	19	25	1,49	10	BMESB1925NE
0.15	19	25	1,49	10	BMESB1925RO
0.15	19	25	1,49	10	BMESB1925VE
0.15	25	25	1,95	8	BMESB2525BI
0.15	25	25	1,95	8	BMESB2525BL
0.15	25	25	1,95	8	BMESB2525GI
0.15	25	25	1,95	8	BMESB2525GR
0.15	25	25	2,00	8	BMESB2525GV
0.15	25	25	1,95	8	BMESB2525MA
0.15	25	25	1,95	8	BMESB2525NE
0.15	25	25	1,95	8	BMESB2525RO
0.15	25	25	1,95	8	BMESB2525VE

I prezzi si riferiscono al singolo nastro

1639ESC

nastro isolante in PVC

Temperatura d'esercizio: 0-80°C
 Carico di rottura: 28N/cm equivalente a 18.6 N/mm²
 Allungamento a rottura: 200%
 Adesione all'acciaio: 2.2N/cm
 Adesione al dorso: 2.2 N/cm
 Rigidità dielettrica: 38kV/mm
 Infiammabilità: ritardante la fiamma
 Norme di riferimento: ASTM-D-1000 ; UL510
 Classificazione: CEI EN 60454-3-1-5/F-PVCP/90



S mm	A mm	L m	€		
0.18	19	20	1,80	10	BMESC1920NE

I prezzi si riferiscono al singolo nastro

1639ETA

nastro isolante in PVC per temperature estreme

Temperatura d'esercizio: -18 ÷ +105°C
 Carico di rottura: 35N/cm equivalente a 19.4 N/mm²
 Allungamento a rottura: 300%
 Adesione all'acciaio: 3.1N/cm
 Adesione al dorso: 2.7 N/cm
 Rigidità dielettrica: 55.5kV/mm
 Infiammabilità: ritardante la fiamma
 Norme di riferimento: ASTM-D-1000 ; UL510
 Classificazione: CEI EN 60454-3-1-5/F-PVCP/90



S mm	A mm	L m	€		
0.18	19	20	5,80	1	BMETA1920NE

1639EAB

nastro isolante autoagglomerante a base di EPR

Temperatura d'esercizio: -40 ÷ +90°C
 Carico di rottura: 2.4 N/mm²
 Allungamento a rottura: 750%
 Rigidità dielettrica: 29.5kV/mm
 Infiammabilità: ritardante la fiamma
 Norme di riferimento: ASTM-D-4388; ASTM-D-4325
 Eccellente resistenza a: umidità, corrosione e agenti chimici



S mm	A mm	L m	€		
0.76	19	9	11,90	1	BMEAB1909NE





GAMMA BLISTER

Per la tua vendita
a libero servizio!

- **Efficienza espositiva**
- **Migliore visibilità**
- **Codice a barre**



SUPPORTO BLISTER:

- PVC Antistrappo
- 4 formati
- Sistema di fissaggio di nuova generazione con fascetta elastica

42NEWK



mm	€	🔧	📦
5,5x5,5	7,30	5	000429505
6x6	7,40	5	000429506
7x7	7,45	5	000429507
8x8	7,75	5	000429508
9x9	8,05	5	000429509
10x10	8,30	5	000429510
11x11	8,80	5	000429511
12x12	8,90	5	000429512
13x13	9,05	5	000429513
14x14	10,20	5	000429514
15x15	11,10	5	000429515
16x16	11,50	5	000429516
17x17	12,10	5	000429517
18x18	12,90	5	000429518
19x19	13,20	5	000429519
20x20	14,90	3	000429520
21x21	16,10	3	000429521
22x22	16,50	3	000429522
23x23	17,90	3	000429523
24x24	18,90	3	000429524
25x25	19,80	2	000429525
26x26	21,30	2	000429526
27x27	23,20	2	000429527
28x28	23,90	2	000429528
29x29	25,50	2	000429529
30x30	27,00	2	000429530
32x32	30,00	2	000429532

55K



mm	€	🔧	📦
6x7	4,65	5	000559012
8x9	4,75	5	000559021
10x11	5,00	5	000559030
10x12	6,65	5	000559033
10x13	7,30	5	000559035
12x13	5,60	5	000559042
12x14	7,55	5	000559045
13x17	8,90	5	000559051
14x15	6,95	5	000559054
14x17	9,70	5	000559057
16x17	7,95	5	000559060
17x19	10,60	2	000559063
18x19	9,45	2	000559066
19x22	12,00	2	000559069
20x22	10,60	2	000559075
21x23	11,20	2	000559078
22x24	13,00	2	000559081
24x26	13,30	2	000559087
24x27	14,50	2	000559090
25x28	15,10	2	000559096
27x29	17,10	2	000559099
27x30	19,70	2	000559102
30x32	18,90	2	000559108

90K



mm	€	🔧	📦
6x7	8,70	5	000909006
8x9	9,35	5	000909012
10x11	10,20	5	000909018
12x13	11,10	5	000909027
14x15	12,10	5	000909033
16x17	13,80	5	000909039
18x19	16,00	5	000909045
20x22	18,40	3	000909051
21x23	20,60	2	000909057
24x26	23,20	2	000909063
24x27	25,50	2	000909067

mm	€	🔧	📦
25x28	27,50	2	000909070
27x29	30,00	2	000909073
30x32	34,00	2	000909080

93K



mm	€	🔧	📦
21x22	35,00	3	000939021

94K



mm	€	🔧	📦
8x10	14,90	2	000949008
9x11	15,50	2	000949009
10x11	16,30	2	000949010
11x13	16,80	2	000949011
12x14	17,90	2	000949012
13x15	17,90	2	000949013
14x15	20,80	2	000949014
14x17	21,30	2	000949015
17x19	21,80	2	000949017
19x22	23,40	2	000949019
22x24	28,50	2	000949022
24x27	31,00	2	000949024
30x32	40,50	2	000949030

96/SC9



96/SC9	€	🔧	📦
1,5-2-2,5-3-4-5-6-8-10 mm	17,60	1	000960374

96/ST6K



96/ST6K	€	🔧	📦
2,5-3-4-5-6-8 mm	12,80	3	000969370

96N/ST6K



96N/ST6K	€	🔧	📦
2,5-3-4-5-6-8 mm	9,30	3	000969640

96BPA/SC9



96BPA/SC9	€	🔧	📦
1,5-2-2,5-3-4-5-6-8-10 mm	40,50	1	000961974

96BP-CL/SC9



96BP-CL/SC9	€	🔧	📦
1,5-2-2,5-3-4-5-6-8-10 mm	44,50	1	000961619

96BPC/SC9



96BPC/SC9	€	🔧	📦
1,5-2-2,5-3-4-5-6-8-10 mm	36,50	1	000960354

96C/AS



"	€	🔧	📦
1/16	1,45	20	000961702
3/32	2,00	20	000961706
1/8	2,10	20	000961710
5/32	2,45	20	000961714
3/16	2,80	20	000961716
7/32	3,15	20	000961718
1/4	3,50	20	000961720
5/16	3,95	10	000961724
3/8	4,80	10	000961728

96LBP/SC9



96LBP/SC9	€	🔧	📦
1,5-2-2,5-3-4-5-6-8-10 mm	43,00	1	000961354

96/BGS7



96/BGS7	€ 26,00	1	000960367
1,5-2-2,5-3-4-5-6 mm			

96/BG7



96/BG7	€ 28,00	1	000960368
2,5-3-4-5-6-8-10 mm			

96TK



mm	€		
2	10,20	5	000969934
2,5	10,20	5	000969935
3	10,60	5	000969936
4	11,00	5	000969938
5	11,30	5	000969940
6	12,90	5	000969941
8	16,30	3	000969943
10	18,80	3	000969945

97BTX/SC8



97BTX/SC8	€ 65,50	1	000970164
T9-T10-T15-T20-T25-T27-T30-T40			

97BTXL/SC8



97BTXL/SC8	€ 75,50	1	000970364
T9-T10-T15-T20-T25-T27-T30-T40			

111K



L mm	€		
100	20,70	3	001119010
150	21,50	3	001119015
200	26,00	3	001119020
250	32,00	3	001119025
300	42,50	3	001119030

123/K4



123/K4	€ 28,50	1	001230504
--------	---------	---	-----------

142K



mm	€		
6	15,50	3	001429006
7	15,50	3	001429007
8	16,10	3	001429008
9	17,10	3	001429009
10	17,60	3	001429010
11	18,20	3	001429011
12	18,80	3	001429012
13	20,10	3	001429013
14	20,70	2	001429014
15	21,90	2	001429015
16	23,70	2	001429016
17	24,10	2	001429017
18	26,00	2	001429018
19	26,50	2	001429019
21	35,00	1	001429021
22	36,00	1	001429022
24	42,00	1	001429024

192/S2

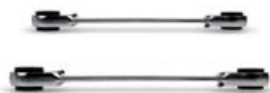

192/S2	€ 55,50	1	001920070
8x10/12x13 mm 16x17/18x19 mm			

195K



mm	€		
8x10	17,90	2	001959010
12x13	20,30	2	001959013
14x15	21,30	2	001959015
16x18	24,70	2	001959018
17x19	26,00	2	001959019

374K



L mm	€		
240	33,00	1	003749024

850MQ



△1000 V



L mm	€		
233	20,00	1	008500910

855P



L1 mm	€		
240	60,50	1	008550010

860/58K



L



L mm	€		
126	64,50	1	008609884

860LP



SxA

L

0,8x



SxA mm	€		
0,5x3	1,58	5	008600005
0,6x4,5	1,58	5	008600010
0,8x5,5	1,58	5	008600015
1x5,5	1,58	5	008600020
1,2x6,5	1,58	5	008600025

860PH



L

PH



PH	€		
0	1,58	5	008600220
1	1,58	5	008600225
2	1,58	5	008600230
3	1,58	5	008600245
4	2,28	5	008600250

860PZ



PZ	€	5	008600320
1	1,58	5	008600320
2	1,58	5	008600325
3	1,58	5	008600330
4	2,28	5	008600335

860PE



mm	€	5	008600101
2	1,68	5	008600101
2,5	1,68	5	008600102
3	1,68	5	008600103
4	1,68	5	008600104
5	1,68	5	008600105
6	1,68	5	008600106
8	2,10	5	008600108
10	2,10	5	008600110

860TX



°	€	5	008600704
T6	2,10	5	008600704
T7	2,10	5	008600705
T8	2,10	5	008600710
T9	2,10	5	008600715
T10	1,68	5	008600720
T15	1,68	5	008600725
T20	1,68	5	008600730
T25	1,68	5	008600735
T27	1,68	5	008600740
T30	1,68	5	008600745
T40	1,68	5	008600750

860RTX



°	€	5	008600550
T9	2,28	5	008600550
T10	2,28	5	008600555
T15	2,28	5	008600560
T20	2,28	5	008600565
T25	2,28	5	008600570
T27	2,28	5	008600575
T30	2,28	5	008600580
T40	2,28	5	008600585

860/C27



860/C27	€	1	008600880
	73,00	1	008600880

860MIX/A10



860MIX/A10	€	1	008600900
	30,50	1	008600900

860TX/A10



860TX/A10	€	1	008600970
	32,50	1	008600970

860MIX/A31



860MIX/A31	€	1	008600902
	71,50	1	008600902

862F/A7



862F/A7	€	1	008620950
	41,50	1	008620950

900K



mm	€	10	009009040
4	3,70	10	009009040
4,5	3,70	10	009009045
5	3,70	10	009009050
5,5	3,70	10	009009055
6	3,70	10	009009060
7	3,70	10	009009070
8	3,70	10	009009080
9	3,70	10	009009090
10	3,70	10	009009100
11	3,70	10	009009110
12	3,70	10	009009120
13	3,75	10	009009130
14	3,80	10	009009140

900/20LK



L mm	€	5	009009819
100	8,30	5	009009819

900/25K



L mm	€	5	009009830
41	15,30	5	009009830

900BG/30K



L mm	€	5	009009834
128	8,05	5	009009834

900/55K



L mm	€	5	009009870
125	41,00	5	009009870

900/55ZK



L mm	€	3	009009882
125	41,00	3	009009882

900/58K



L mm	€	2	009009884
126	62,50	2	009009884

910AK

3/8"



mm	€	5	009109006
6	6,00	5	009109006
7	6,00	5	009109007
8	6,00	5	009109008
9	6,00	5	009109009
10	6,00	5	009109010
11	6,00	5	009109011
12	6,20	5	009109012
13	6,20	5	009109013
14	6,20	5	009109014
15	6,20	5	009109015
16	6,90	5	009109016
17	6,90	5	009109017
18	6,90	5	009109018
19	6,90	5	009109019
20	7,40	5	009109020
21	7,40	5	009109021
22	7,55	5	009109022

910/21K

3/8"



L mm	€	5	009109822
125	10,60	5	009109822

910/25K

3/8"



L mm	€	5	009109830
54,6	19,10	5	009109830

910/55K

3/8"



L mm	€	3	009109882
200	44,50	3	009109882

910/58K

3/8"



L mm	€	1	009109884
222	68,50	1	009109884

920AK

1/2"



mm	€	10	009209010
10	6,05	10	009209010
11	6,05	10	009209011
12	6,05	10	009209012
13	6,30	10	009209013
14	6,30	10	009209014
15	6,30	10	009209015
16	7,00	10	009209016
17	7,00	10	009209017
18	7,00	10	009209018
19	7,00	10	009209019
20	7,65	5	009209020
21	7,65	5	009209021
22	7,65	5	009209022
23	8,90	5	009209023
24	8,90	5	009209024
25	8,90	5	009209025
26	9,25	5	009209026
27	9,25	5	009209027
28	9,25	5	009209028
29	9,70	5	009209029
30	9,70	5	009209030
32	10,10	5	009209032

920/21K

1/2"



L mm	€	5	009209822
125	14,50	5	009209822

920/25K

1/2"



L mm	€	5	009209830
75	22,90	5	009209830

920/55K

1/2"



L mm	€	3	009209882
275	54,00	3	009209882

920/58K

1/2"



L mm	€	1	009209926
281	81,50	1	009209926

935K



mm	€	5	009359105
6x7	7,00	5	009359105
8x9	7,55	5	009359111
10x11	8,40	5	009359115
12x13	9,45	5	009359117
14x15	10,80	5	009359126
16x17	11,80	5	009359128
18x19	14,00	5	009359131
20x22	16,80	3	009359138

937K



mm	€	5	009379006
6x6	7,55	5	009379006
7x7	7,85	5	009379007
8x8	8,15	5	009379008
9x9	8,60	5	009379009
10x10	9,05	5	009379010
11x11	9,45	5	009379011
12x12	10,40	5	009379012
13x13	10,60	5	009379013
14x14	11,60	5	009379014
15x15	12,90	5	009379015
16x16	13,90	5	009379016
17x17	14,40	5	009379017
18x18	14,70	5	009379018
19x19	15,20	5	009379019
20x20	17,30	5	009379020
21x21	18,90	3	009379021
22x22	19,80	3	009379022

943BXX



mm	€	5	009439005
5,5	14,70	5	009439005
6	14,70	5	009439006
7	15,80	5	009439007
8	15,80	5	009439008
10	17,10	3	009439010
13	18,20	3	009439013

951K



mm	€	5	009519521
2	16,30	5	009519521
2,5	16,30	5	009519525
3	16,30	5	009519530
3,5	16,80	5	009519535
4	16,80	5	009519540
4,5	18,40	5	009519545
5	18,40	5	009519550
6	21,10	5	009519560
8	22,90	5	009519580
10	28,50	5	009519610



1032K



L mm	€		
140x0,9	20,90	5	010329013
140x1,3	20,50	5	010329014
180	22,10	5	010329017

1033K



L mm	€		
140x0,9	23,80	5	010339013
140x1,3	23,30	5	010339014
180	24,40	5	010339017

1034K



L mm	€		
130x0,9	23,80	5	010349013
130x1,3	23,30	5	010349014
170	24,40	5	010349017

1036K



L mm	€		
140x0,9	23,20	5	010369013
140x1,3	22,10	5	010369014
175	23,30	5	010369017

1037K



L mm	€		
140x0,9	25,50	5	010379013
140x1,3	24,20	5	010379014
175	25,50	5	010379017

1038K



L mm	€		
135x0,9	25,50	5	010389013
135x1,3	24,20	5	010389014
175	25,50	5	010389017

1044K



L mm	€		
250	29,50	5	010449250

1044FK



L mm	€		
250	23,20	5	010449015

1046K



L mm	€		
240	33,00	5	010469240

1048K



L mm	€		
175	28,50	3	010489010
250	31,00	5	010489250

1048VK



L mm	€		
175	23,70	3	010489110
250	27,50	5	010489025

1052K



L mm	€		
140	22,80	3	010529014
190	25,50	3	010529019
240	27,50	3	010529024

1082K



L mm	€		
140	21,60	5	010829004
160	23,20	5	010829006

1082GK



L mm	€		
140	18,90	5	010829064
160	19,80	5	010829066

1082BMK



L mm	€		
140	27,00	3	010829034
160	30,00	3	010829036

1082GBMK



L mm	€		
140	23,90	3	010829264
160	26,50	3	010829266

1084K



L mm	€		
160	25,50	3	010849006

1084GK

L mm 160 € 22,10 5 010849066

1084BMK

L mm 160 € 31,50 3 010849036

1084GBMK

L mm 160 € 34,50 3 010849266

1088K

L mm 160 € 31,50 2 010889006

1088BMK

L mm 160 € 38,50 2 010889036

1096K

L mm 200 € 19,70 5 010969020

1098K

L mm 190 € 17,00 5 010989190
220 € 19,20 5 010989220

1098PLK

L mm 220 € 21,10 5 010989320

1112K

L mm 200 € 22,20 2 011129020

1122K

L mm 250 € 30,50 2 011229020

1123K

L mm 250 € 30,50 2 011239020

1124K

L mm 250 € 30,50 2 011249020

1128BAX

L mm 150 € 28,50 5 011280088

1128BCX

L mm 155 € 24,00 5 011280080

1128BMX

L mm 147 € 14,80 5 011280051

1128BSX

L mm 148 € 25,50 5 011280061

1128FX

L mm 145 € 27,50 5 011280090

1128FXS



L mm	€	🔧	📦
145	32,50	5	011280095

1129BMK



L mm	€	🔧	📦
145	14,60	5	011299000

1130BMX



L mm	€	🔧	📦
185	16,80	1	011300002

1132K



L mm	€	🔧	📦
170	42,00	2	011329107

1132BMK



L mm	€	🔧	📦
170	52,00	2	011329137

1142BMK



L mm	€	🔧	📦
160	34,50	3	011429036

1149F



L mm	€	🔧	📦
175	14,50	1	011490010

1150K



L mm	€	🔧	📦
160	19,40	5	011509046
180	21,00	5	011509048
200	23,10	5	011509050
220	25,00	2	011509052

1150GK



L mm	€	🔧	📦
160	18,30	5	011509066
180	19,90	5	011509068
200	21,60	5	011509070
220	23,20	2	011509072

1150BMK



L mm	€	🔧	📦
160	23,90	3	011509146
180	26,00	3	011509148
200	29,00	3	011509150
220	31,00	2	011509152

1150GBMK



L mm	€	🔧	📦
160	22,40	3	011509266
180	23,90	3	011509268
200	27,00	3	011509270
220	29,00	2	011509272

1162K



L mm	€	🔧	📦
160	22,70	5	011629006
200	26,00	5	011629010

1162GK



L mm	€	🔧	📦
160	19,40	5	011629066
200	22,40	5	011629070

1162BMK



L mm	€	🔧	📦
160	27,50	3	011629036
200	31,50	3	011629040

1162GBMK



L mm	€	🔧	📦
160	23,90	3	011629266
200	28,00	3	011629270

1164K



L mm	€	🔧	📦
160	24,80	5	011649006
200	27,50	5	011649010

1164BMK



L mm	€	🔧	📦
160	30,00	3	011649036
200	34,50	3	011649040

1166K



L mm	€	🔧	📦
160	22,70	5	011669006
200	26,00	5	011669010

1166GK



L mm	€	🔧	📦
160	19,40	5	011669066
200	22,40	5	011669070

1166BMK



L mm	€	🔧	📦
160	27,50	3	011669036
200	31,50	3	011669040

1166GBMK



L mm	€	🔧	📦
160	23,90	3	011669266
200	28,00	3	011669270

1168K



L mm	€	🔧	📦
160	24,80	5	011689006
200	27,50	5	011689010

1168GK



L mm	€	🔧	📦
160	21,00	5	011689066
200	23,70	5	011689070

1168BMK



L mm	€	🔧	📦
160	30,00	3	011689036
200	34,50	3	011689040

1168GBMK



L mm	€	🔧	📦
160	26,50	3	011689266
200	30,50	3	011689270

1201E/K



SxAxL mm	€	🔧	📦
0,4x2,5x50	3,65	5	012019203
0,4x2,5x75	3,75	5	012019206
0,5x3x75	3,80	5	012019209
0,5x3x100	4,10	5	012019212
0,6x3,5x75	4,10	5	012019218
0,6x3,5x100	4,20	5	012019221
0,8x4x100	4,25	5	012019230
0,8x4x125	4,45	5	012019233
0,8x4x150	4,90	5	012019236
1,0x5,5x100	5,25	5	012019239
1,0x5,5x125	5,55	5	012019240
1,0x5,5x150	5,65	5	012019242
1,2x6,5x100	6,30	5	012019248
1,2x6,5x125	6,45	5	012019250
1,2x6,5x150	6,55	5	012019251
1,2x8x150	8,50	3	012019257
1,2x8x200	9,15	3	012019260
1,6x10x200	10,40	3	012019266

1201EN/K



SxAxL mm	€	🔧	📦
0,8x4x30	5,10	3	012019303
1,2x6,5x30	5,45	3	012019306

1202E/K



PHxDxL mm	€	🔧	📦
0x3x60	3,75	5	012029203
0x3x100	4,20	5	012029206
1x4,5x80	4,85	5	012029209
1x4,5x120	5,40	5	012029212
2x6x100	6,45	5	012029218
2x6x150	6,95	5	012029221
3x8x150	8,90	3	012029224
4x9,5x200	11,40	3	012029227

1202EN/K



PHxDxL mm	€	🔧	📦
1x4,5x30	5,10	3	012029303
2x6x30	5,45	3	012029306

1204E/K



SxDxL mm	€	🔧	📦
0,4x2,5x60	3,70	5	012049103
0,6x3x75	3,80	5	012049106
0,5x3x100	3,90	5	012049109
0,8x4x100	4,35	5	012049112
0,8x4x125	4,60	5	012049115
1,0x5x125	5,30	5	012049118
1,0x5x150	5,85	5	012049121
1,2x6,5x150	6,30	5	012049124

1207E TX/K



	€	🔧	📦
T5	5,55	5	012079105
T6	5,95	5	012079106
T7	6,10	5	012079107
T8	6,20	5	012079108
T9	6,45	5	012079109
T10	7,20	5	012079110
T15	7,30	5	012079115
T20	7,40	5	012079120
T25	7,65	5	012079125
T27	8,05	5	012079127
T30	8,15	5	012079130
T40	9,70	2	012079140
T45	10,50	2	012079145

1208E RTX/K



	€	🔧	📦
T9	6,45	5	012089109
T10	7,20	5	012089110
T15	7,65	5	012089115
T20	7,75	5	012089120
T25	7,95	5	012089125
T27	8,60	5	012089127
T30	9,05	5	012089130
T40	10,60	2	012089140

1209E PZ/K



PZ	€	🔧	📦
0	4,35	5	012099200
1	5,65	5	012099203
2	7,20	5	012099206
3	10,80	3	012099209
4	11,90	3	012099212

1209EN-PZ/K



	€		
1	5,10	3	012099303
2	5,45	3	012099306

1253



SxAxL mm	€		
0,5x3,5x100	8,00	5	012530001

1254



SxAxL mm	€		
0,5x3x44	8,80	5	012540001

1260K



SxAxL	€		
0,4x2,5x50	4,95	5	012609003
0,4x2,5x75	5,05	5	012609006
0,5x3x75	5,20	5	012609009
0,5x3x100	5,35	5	012609012
0,6x3,5x75	5,55	5	012609018
0,6x3,5x100	5,65	5	012609021
0,8x4x100	6,20	5	012609030
0,8x4x125	6,45	5	012609033
0,8x4x150	6,55	5	012609036
1x5,5x100	7,00	5	012609039
1x5,5x150	7,75	5	012609042
1,5x6,5x100	8,40	5	012609048
1,2x6,5x150	9,05	5	012609051
1,2x8x150	10,90	3	012609057
1,2x8x200	11,30	3	012609060
1,6x10x200	13,60	3	012609066

1260NK



SxAxL mm	€		
0,8x4x30	6,45	5	012609103
1,2x6,5x30	7,10	5	012609106

1260EK



SxAxL mm	€		
1,2x6,5x150	11,50	3	012609156
1,2x8x175	14,10	3	012609157
1,6x10x200	16,30	2	012609159
2x12x250	18,90	2	012609162

1262K



PHxDxL mm	€		
0x3x60	5,20	5	012629003
0x3x100	5,50	5	012629006
1x4,5x80	6,70	5	012629009
1x4,5x120	7,30	5	012629012
2x6x100	8,30	5	012629018
2x6x150	9,15	5	012629021
3x8x150	12,00	3	012629024
4x10x200	15,20	3	012629027

1262NK



PHxDxL	€		
1x4,5x30	6,45	5	012629103
2x6x30	7,10	5	012629106

1262EK



PHxDxL mm	€		
2x6x150	11,50	3	012629153
3x8x175	13,90	3	012629156
4x10x200	17,50	3	012629159

1264K



SxDxL mm	€		
0,5x2,5x60	4,95	5	012649003
0,6x3x75	5,20	5	012649006
0,6x3x100	5,35	5	012649009
0,8x4x100	6,20	5	012649012
0,8x4x125	6,45	5	012649015
1x5x125	7,10	5	012649018
1x5x150	7,55	5	012649021
1,2x6,5x150	9,05	5	012649024

1267TXK



	€		
T5	7,20	5	012679005
T6	7,55	5	012679006
T7	7,75	5	012679007
T8	8,05	5	012679008
T9	8,50	5	012679009
T10	8,80	5	012679010
T15	9,35	5	012679015
T20	9,80	5	012679020
T25	10,50	5	012679025
T27	10,90	5	012679027
T30	11,40	5	012679030
T40	13,20	2	012679040
T45	14,50	2	012679045

1268RTXK



	€		
T9	9,20	3	012689009
T10	9,50	3	012689010
T15	9,85	3	012689015
T20	10,50	3	012689020
T25	10,70	3	012689025
T27	11,40	3	012689027
T30	11,60	3	012689030
T40	13,40	2	012689040

1269PZK



PZ	€		
0	5,95	5	012699000
1	7,65	5	012699001
2	9,25	5	012699002
3	12,90	3	012699003
4	16,50	3	012699004

1269N/PZK



PZ	€		
1	6,45	5	012699011
2	7,10	5	012699012

1290K



SxAxL mm	€	U	PC
0,4x2,5x50	6,10	5	012909003
0,4x2,5x75	6,30	5	012909006
0,5x3x75	6,45	10	012909009
0,5x3x100	6,65	10	012909012
0,6x3,5x75	7,20	10	012909018
0,6x3,5x100	7,30	10	012909021
0,8x4x100	7,40	10	012909030
0,8x4x125	7,65	10	012909033
0,8x4x150	8,05	10	012909036
1x5,5x100	8,30	10	012909039
1x5,5x150	9,25	10	012909042
1,2x6,5x100	10,20	10	012909048
1,2x6,5x150	10,70	10	012909051
1,2x8x150	13,40	3	012909057
1,2x8x200	14,20	3	012909060
1,6x10x200	16,60	3	012909066

1290NK



SxAxL mm	€	U	PC
0,8x4x30	7,85	5	012909103
1,2x6,5x30	8,70	5	012909106

1290K/INOX



SxAxL mm	€	U	PC
0,4x2,5x50	7,95	4	012909403
0,5x3x75	8,05	4	012909409
0,8x4x100	8,50	4	012909430
1,0x5,5x150	10,60	4	012909442
1,2x6,5x150	12,10	4	012909451

1292K



PHxDxL mm	€	U	PC
0x3x60	5,90	10	012929003
0x3x100	6,55	5	012929006
1x4,5x80	7,95	10	012929009
1x4,5x120	8,80	10	012929012
2x6x100	10,30	10	012929018
2x6x150	11,10	10	012929021
3x8x150	14,00	3	012929024
4x10x200	19,30	3	012929027

1292NK



PHxDxL mm	€	U	PC
1x4,5x30	7,55	5	012929103
2x6x30	8,15	5	012929106

1292K/INOX



PHxDxL mm	€	U	PC
0x3x60	7,40	4	012929403
1x4,5x80	8,80	4	012929409
2x6x100	10,60	4	012929418

1294K



SxDxL mm	€	U	PC
0,5x2,5x60	5,70	5	012949003
0,6x3x75	6,00	5	012949006
0,8x4x100	7,40	5	012949012
1x5x125	9,35	5	012949018

1298RTKX



	€	U	PC
T9	12,20	5	012989009
T10	12,50	5	012989010
T15	13,20	5	012989015
T20	13,30	5	012989020
T25	13,60	5	012989025
T27	14,70	5	012989027
T30	15,20	5	012989030
T40	16,30	2	012989040

1299PZK



PZ	€	U	PC
0	8,30	5	012999000
1	9,70	5	012999003
2	13,00	5	012999006

1299N/PZK



PZ	€	U	PC
1	9,45	5	012999021
2	10,30	5	012999024

1472VW



L mm	€	U	PC
200	39,00	1	014720051

1473P



A Max mm	€	U	PC
53	30,50	1	014730020

1497RC



	€	U	PC
1497RC	62,50	1	014970351

1600Q 8



	€	U	PC
1600Q 8	24,00	1	016000008

1600Q 10



	€	U	PC
1600Q 8	24,00	1	016000008

1603K



mm2	€	U	PC
0÷8	13,70	5	016039001

1603BK



mm ²	€		
0-8	50,50	2	016039010

1691BM

CE



L m	€		
5	13,20	1	016910205
8	19,80	1	016910208
10	24,00	1	016910210

1692

CE



L m	€		
2	6,40	5	016920052
3	8,00	5	016920053
5	11,40	5	016920055
8	16,50	5	016920058

1693

CE



IP54



H mm	€		
100	102,00	1	016930020

1729CG



L mm	€		
310	19,50	2	017290200

1729DM 450



L mm	€		
450	22,50	4	017290450

1741U



200 mm



Ø mm	2,4	3	3,2	4	4,8
Alluminio	•	•	•	•	•
Acciaio	•	•	•	•	•
Inox	•	•	•	•	•

1741U	€		
	38,50	1	017410450

1741B



250 mm



Ø mm	2,4	3,2	4	4,8	5
Alluminio	•	•	•	•	•
Acciaio	•	•	•	•	•
Inox	•	•	•	•	•

1741B	€		
	32,50	1	017410000

1760K

CE



180 mm

CAT III-1000V



1760K	€		
	31,00	1	017600140

1762K



Ø mm	€		
2-2,5-3 3,5-4-4,5	26,00	2	017629001

1771



18 mm

170 mm



1771	€		
	7,90	10	017710000

1770BM



A

L



L mm	€		
140	10,70	10	017700050

1771BM



A

L



L mm	€		
170	17,20	10	017710050

1771HD



A

L



L mm	€		
190	19,30	5	017710100

1772R



A

L



L mm	€		
125	14,50	5	017720006



1773A



L mm 180 € 15,20 10 017730000

1777BMT



L mm 170 € 23,30 5 017770050

1777T



L mm 160 € 21,80 5 017770030

1783



L mm 215 € 12,70 5 017830021
240 € 14,20 5 017830024

1820

CE



1820 30 30W € 37,50 1 018200003
L = 210mm
1820 60 60W € 42,50 1 018200006
L = 220mm
1820 80 80W € 60,50 1 018200008
L = 260mm

1822

CE



1822 120 120W € 92,00 1 018220012
LxA = 250x125 mm
1822 180 180W € 97,00 1 018220018
LxA = 250x125mm
1822 320 320W € 121,00 1 018220032
LxA = 250x140mm

1833S



L mm 150 € 31,50 1 018330002

1833M



L mm 162 € 39,00 1 018330003

1833L



L mm 196 € 64,50 1 018330004

1833XL



L mm 300 € 81,00 1 018330005

1833L/USB



L mm 240 € 95,00 1 018330054

1834RR



1834RR € 43,00 1 018340520

1836A



1836A € 43,50 1 018360050

1836B



1836B € 106,00 1 018360200

Beta

Beta

1837F



L mm 460 € 70,00 1 018370050

1837F/USB



L mm 460 € 103,00 1 018370060

1838COB



1838COB € 76,00 1 018380010

1838P



1838P € 65,50 1 018380005

1838S



L mm 260 € 71,00 1 018380122

1838SLIM

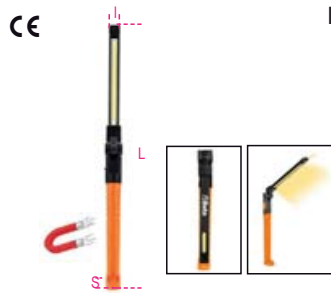

L mm 307 € 60,00 1 018380221

6888B1/4

supporto blister per bussole 1/4"



6888B1/4 € 0,50 50 068880900

6888B3/8

supporto blister per bussole 3/8"



6888B3/8 € 0,60 50 068880910

6888B1/2

supporto blister per bussole 1/2"



6888B1/2 € 0,60 50 068880920



Beta



SOLUZIONI ESPOSITIVE PER IL PUNTO VENDITA

Beta
SHOP
in Shop



**PROGETTA
il tuo corner Beta**

www.beta-tools.com/planner3d/

38/DS1

espositore da parete
con 75 utensili a percussione



495x260x332 mm

Espositore
con assortimento
38/DS1 € 596,00 1 000380701

		n.
30	Ø 2 - 3 - 4 - 5 - 6 mm	5
31	Ø 2 - 3 - 4 - 5 - 6 - 8 - 10 mm	5
32	Ø 3 - 4 - 5 mm	5

Espositore
vuoto
38/DVS1 € 92,00 1 000380751

38/DS2

espositore da parete
con 65 utensili a percussione

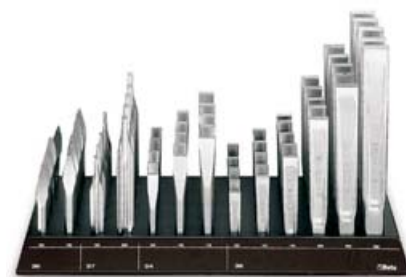

495x260x332 mm

Espositore
con assortimento
38/DS2 € 1.109,00 1 000380702

		n.
34	125 - 150 - 175 mm	5
35	100 - 125 - 150 - 200 - 250 - 300 mm	5
36	125 - 150 mm	5
37	150 - 200 mm	5

Espositore
vuoto
38/DVS2 € 92,00 1 000380752

942BX/DG

espositore da parete
con 43 chiavi a bussola esagonale
con impugnatura tipo corto



330x260x332 mm

Espositore
con assortimento
942BX/DG € 609,00 1 009420701

	n.
○ 942BX 5 - 5,5 mm	3
6 - 7 mm	6
8 - 9 - 10 mm	5
11 mm	2
12 mm	3
13 mm	5

Espositore
vuoto
942BX/DVG € 80,00 1 009420751

943BX/DG

espositore da parete
con 43 chiavi a bussola esagonale
con impugnatura tipo lungo



330x260x332 mm

Espositore
con assortimento
943BX/DG € 654,00 1 009430701

	n.
○ 943BX 5 - 5,5 mm	3
6 - 7 mm	6
8 - 9 - 10 mm	5
11 mm	2
12 mm	3
13 mm	5

Espositore
vuoto
943BX/DVG € 80,00 1 009430751

944BX/DG

espositore da parete
con 43 chiavi a bussola esagonale profonda
con impugnatura tipo lungo



330x260x332 mm

Espositore
con assortimento
944BX/DG € 757,00 1 009440701

	n.
○ 944BX 5 - 5,5 mm	3
6 - 7 mm	6
8 - 9 - 10 mm	5
11 mm	2
12 mm	3
13 mm	5

Espositore
vuoto
944BX/DVG € 80,00 1 009430751

943MQ/BG

espositore da parete
con 30 chiavi a bussola esagonale
con impugnatura



⚠ 1000 V ⚡

330x260x332 mm

Espositore
con assortimento
943MQ/BG € 515,00 1 009430281

	n.
○ 943MQ 5,5 - 6 - 7 - 8 - 10 - 13 mm	5

Espositore
vuoto
943BG-MQ/DV € 80,00 1 009430285

1203/E1P

espositore da parete
con 82 giravite



495x260x310 mm

Espositore
con assortimento
1203E/E1P € 395,00 1 012031301

	n.
● 1201 0,4x2,5x50 - 0,5x3x75 - 0,6x3,5x100 - 0,8x4x100 - 0,8x4x125 mm	7
1,0x5,5x100 - 1,0x5,5x150 - 1,2x6,5x150 mm	6
1,2x8x150 mm	5
⊕ 1202 PH0x3x60 mm	7
PH1x4,5x80 - PH2x6x100 mm	6
PH3x8x150 mm	5

Espositore
vuoto
1203E/EV1P € 92,00 1 012031351

1203/E4P

espositore da parete
con 85 giravite



495x260x310 mm

Espositore
con assortimento
1203E/E4P € 379,00 1 012031304

	n.
● 1201 0,4x2,5x50 - 0,5x3x75 - 0,8x4x125 mm	7
1,0x5,5x100 - 1,0x5,5x150 - 1,2x6,5x150 mm	6
● 1204 0,4x2,5x60 - 0,5x3x100 - 0,8x4x100 mm	7
1,0x5x125 mm	6
⊕ 1209PZ PZ0x3x60 mm	7
PZ1x4,5x80 - PZ2x6x100 mm	6

Espositore
vuoto
1203E/EV4P € 92,00 1 012031354

1203/E5P

espositore da parete
con 82 giravite



495x260x310 mm

Espositore con assortimento
1203E/E5P € 402,00 1 012031305

		n.	
+	1202	PH0x3x60 mm	7
		PH1x4,5x80 - PH1x4,5x120	6
		PH2x6x100 - PH2x6x150 mm	5
		PH3x8x150 mm	5
●	1204	0,4x2,5x60 - 0,5x3x100 - 0,8x4x100 mm	7
		1,0x5x125 mm	6
+	1209PZ	PZ0x3x60 mm	7
		PZ1x4,5x80 - PZ2x6x100 mm	6

Espositore vuoto
1203E/EV5P € 92,00 1 012031355

1203/E10P

espositore da parete
con 80 giravite



495x260x310 mm

Espositore con assortimento
1203E/E10P € 542,00 1 012031310

		n.	
●	1207TX	T6	4
		T7	3
		T8	7
		T9 - T10 - T15 - T20 - T25	6
		T27 - T30	3
		T9 - T10	3
+	1208RTX	T15 - T20 - T25	6
		T27 - T30	3

Espositore vuoto
1203E/EV10P € 92,00 1 012031360

1263/E78

Espositore da parete con 78 giravite



495x260x310 mm

Espositore con assortimento
1263/E78 € 508,00 1 012630510

●	1260	2,5x75-3x75-3,5x100 mm	7
		4x100-4x125-5,5x100-5,5x150-6,5x150 mm	6
		8x150 mm	4
+	1262	PH0x60 mm	7
		PH1x80-PH2x100 mm	6
		PH3x150	4

Espositore vuoto
1263/EV78 € 92,00 1 012630511

1263/E74

espositore da parete
con 74 giravite



495x260x310 mm

Espositore con assortimento
1263/E74 € 475,00 1 012630540

●	1264	2,5x60 mm	7
		3x75 mm	3
		3x100 - 4x100 mm	4
		4x125 - 5x150 mm	2
		5x125 - 6,5x150 mm	4
+	1262	PH 8x150	3
		PH 3x60 - 3x100 mm	7
		PH 4,5x80 - 4,5x120 mm	6
		PH 6x100 mm	10
		PH 6x150 mm	5

Espositore vuoto
1263/EV74 € 92,00 1 012630541

1263/E85

espositore da parete
con 85 giravite



495x260x377 mm

Espositore con assortimento
1263/E85 € 566,00 1 012630550

●	1260	2,5x50 mm	7
		2,5x75 mm	6
		3x75 - 3x100 - 3,5x100 mm	7
		4x100 - 4x125 - 5,5x125 - 5,5x150 - 6,5x150 mm	6
		8x150 mm	4
	1260E	10x200 mm	3
	12x250 mm	2	
	4x30 - 6,5x30 mm	6	

Espositore vuoto
1263/EV85 € 92,00 1 012630551

1263/E70

espositore da parete
con 70 giravite



495x260x327 mm

Espositore con assortimento
1263/E70 € 557,00 1 012630560

+	1262	PH0x60 - PH0x100 mm	7
		PH1x80 - PH1x120 mm	6
		PH2x100 mm	9
		PH2x150 - PH3x150 mm	5
	PH4x200 mm	4	
+	1262E	PH2x150 mm	5
		PH3x175 mm	4
+	1262N	PH1x30 - PH2x30 mm	6

Espositore vuoto
1263/EV70 € 92,00 1 012630561

1263/E50

espositore da parete
con 50 giravite



330x260x269 mm

Espositore
con assortimento
1263/E50 € 293,00 1 012630570

		n.
● 1264	2,5x60 - 3x75 - 3x100 mm	7
	4x100 - 4x125 - 5x125 - 5x150 mm	6
	6,5x150 mm	5

Espositore
vuoto
1263/EV50 € 80,00 1 012630571

1263/E62

espositore da parete
con 62 giravite



495x260x257 mm

Espositore
con assortimento
1263/E62 € 538,00 1 012630590

		n.
● 1267TX	T5	5
	T6	6
	T7	5
	T8	6
	T9	5
	T10 - T15 - T20	6
	T25	5
	T27 - T30	4
	T40 - T45	2

Espositore
vuoto
1263/EV62 € 92,00 1 012630591

1263/E39

espositore da parete
con 39 giravite



330x260x257 mm

Espositore
con assortimento
1263/E39 € 380,00 1 012630595

		n.
⊕ 1268RTX	T9x60 - T10x80 - T15x80 T20x100 - T25x100 mm T27x115 mm	6
	T30x115 mm	4
	T30x115 mm	3
	T40x130 mm	2

Espositore
vuoto
1263/EV39 € 80,00 1 012630596

1263/E40

espositore da parete
con 40 giravite



330x260x327 mm

Espositore
con assortimento
1263/E40 € 339,00 1 012630580

		n.
⊕ 1269	PZ0x60 mm	7
	PZ1x80 mm	6
	PZ2x100 - PZ3x150 - PZ4x200 mm	5
⊕ 1269N	PZ1x30 - PZ2x30 mm	6

Espositore
vuoto
1263/EV40 € 80,00 1 012630581

1273MQ/E1

espositore da parete
con 40 giravite



△ 1000 V

330x260x332 mm

Espositore
con assortimento
1273MQ/E1 € 431,00 1 012730312

		n.
⊕ 1272MQ	PH0x60 - PH1x80 mm	5
	PH2x100 mm	3
	PH3x150 mm	2
● 1274MQ	3x100 - 4x100 - 5,5x125 - 6,5x150 mm	5
	8x175 mm	3
	10x200 mm	2

Espositore
vuoto
1273BG-MQ/DV € 80,00 1 012730651

1273MQ/E2

espositore da parete
con 43 giravite



△ 1000 V

330x260x332 mm

Espositore
con assortimento
1273MQ/E2 € 489,00 1 012730313

		n.
⊕ 1272MQ/F	4,5x80 - 6x100 mm	3
● 1274MQ/F	3,5x100 - 4,5x100 - 5,5x125 - 6,5x150 mm	3
⊕ 1275MQ/C	4,5x80 - 6x100 mm	5
⊕ 1276MQ/C	4,5x80 - 6x100 mm	5
● 1279MQ/F	4,5x80 6x100	3 2

Espositore
vuoto
1273BG-MQ/DV-2 € 80,00 1 012730653

1293BX/DA

espositore da parete
con 90 giravite



495x260x332 mm

Espositore
con assortimento
1293BX/DA € 735,00 1 012930701

		n.
● 1290	3x75 - 3,5x100 - 4x100 - 4x125 5,5x100 - 5,5x150 mm 6,5x150 mm 8x150 mm 10x200 mm	7 6 3 2
● 1290N	4x30 - 6,5x30 mm	3
⊕ 1292	PH0x60 - PH1x80 mm PH2x100 mm PH3x150 mm	7 6 5
⊕ 1292N	PH1x30 - PH2x30 mm	3

Espositore
vuoto
1293BX/DVA € 92,00 1 012930751

1293BX/DD

espositore da parete
con 48 giravite



330x260x332 mm

Espositore
con assortimento
1293BX/DD € 348,00 1 012930704

		n.
● 1294	2,5x60 - 3x75 - 3x100 - 4x100 4x150 - 5x125 mm 6,5x150 mm	7 6

Espositore
vuoto
1293BX/DVD € 80,00 1 012930754

1293BX/DE

espositore da parete
con 42 giravite



330x260x332 mm

Espositore
con assortimento
1293BX/DE € 515,00 1 012930705

		n.
⊕ 1299PZ	PZ0x60 - PZ1x80 mm PZ2x100 mm PZ3x150 - PZ4x200 mm	7 6 5
⊕ 1299N/PZ	PZ1x30 - PZ2x30 mm	6

Espositore
vuoto
1293BX/DVE € 80,00 1 012930755

1293BX/DF

espositore da parete
con 59 giravite



330x260x332 mm

Espositore
con assortimento
1293BX/DF € 686,00 1 012930706

		n.
⊕ 1297TX	T6 - T8 - T10 - T15 - T20 - T25 T27 - T30 T40	7 6 5

Espositore
vuoto
1293BX/DVF € 80,00 1 012930756

C68

parete espositiva vuota Beta



1000x560x2200 mm

		€		
C68/1	1 m	1.610,00	1	068000001
C68/2	2 m	2.810,00	1	068000002
C68/3	3 m	4.000,00	1	068000003
C68/4	4 m	5.200,00	1	068000004
C68/5	5 m	6.390,00	1	068000005
C68/6	6 m	7.590,00	1	068000006
C68/7	7 m	8.780,00	1	068000007
C68/8	8 m	9.980,00	1	068000008
C68/9	9 m	11.170,00	1	068000009
C68/10	10 m	12.370,00	1	068000010

C68 G

gondola espositiva vuota



1000x1120x1600 mm

		€		
C68G/1	1 m	1.490,00	1	068000051
C68G/2	2 m	2.730,00	1	068000052
C68G/3	3 m	3.960,00	1	068000053
C68G/4	4 m	5.200,00	1	068000054

C88 R/1

parete espositiva vuota Robur



1000x560x2200 mm

C88R/1	1 m	€ 1.610,00	1	088000001
--------	-----	------------	---	-----------

C88VE

vasca espositiva per pareti C88 R/1

adatta ad alloggiare bobine di catena art.8120



C88VE		€ 200,00	1	088000120
-------	--	----------	---	-----------

C88SE

espositore per bobine di catena genovese



C88SE		€ 440,00	1	088000130
-------	--	----------	---	-----------

1700x600x600 mm

6888

ganci per espositori C60 - C61 - C68 - C88

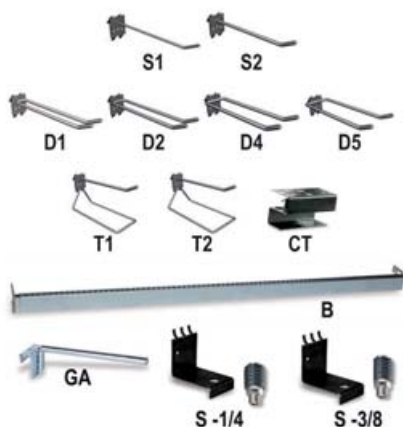

	€			
6888S1	3,30	10	068880011	
6888S2	3,30	10	068880012	
6888D1	5,20	5	068880021	
6888D2	5,20	5	068880022	
6888D4	5,40	5	068880024	
6888D5	5,40	5	068880025	
6888T1	7,40	5	068880031	
6888T2	7,40	5	068880032	
6888CT	14,00	1	068880044	
6888B	42,00	1	068880100	
6888GA	16,50	3	068880120	
6888S-1/4	31,00	1	068880605	
6888S-3/8	31,00	1	068880610	

6800 VE

vetrina per parete espositiva C68 e C68 R/1



	€			
6800VE/1	800,00	1	068000401	
6800VE/2	1.220,00	1	068000402	
6800VE/3	1.640,00	1	068000403	
6800VE/4	2.060,00	1	068000404	
6800VE/5	2.480,00	1	068000405	



ACCESSORI C68



	€			
6800AE	160,00	1	068000145	
6800AI	330,00	1	068000140	
6800AD/P	565,00	1	068000143	

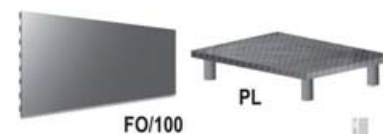
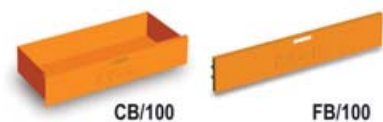

	€			
6800CB/100	185,00	1	068000104	
6800FB/100	65,00	1	068000109	
6800FO/100	45,00	1	068000108	
6800PL	170,00	1	068000137	
6800RP/100	60,00	1	068000150	
6800GR/37	25,00	1	068000159	

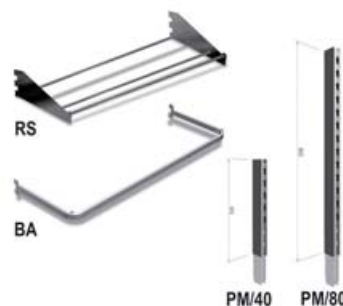

	€			
6800BA	90,00	1	068000130	
6800RS	70,00	1	068000135	
6800PM/40	60,00	1	068000171	
6800PM/80	80,00	1	068000172	



6600 M/14

assortimento 154 utensili,
con ganci senza pannello



6600 M/14 € 2.045,00 1 066000014

6600 M/22

assortimento 108 utensili,
con ganci senza pannello



6600 M/22 € 1.315,00 1 066000022

6600 M/27

assortimento 25 utensili,
con ganci senza pannello



6600 M/27 € 930,00 1 066000027

6600 M/29

assortimento 173 utensili,
con ganci senza pannello

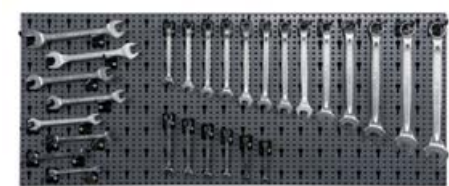

6600 M/29 € 1.790,00 1 066000029

6600 M/33

assortimento 37 utensili, con ganci senza
pannello



6600 M/33 € 1.415,00 1 066000033

6600 M/40

assortimento 100 utensili,
con ganci senza pannello



6600 M/40 € 2.255,00 1 066000040

6600 M/42

assortimento di 65 utensili,
con ganci senza pannello



6600 M/42 € 1.455,00 1 066000042

6600 M/44

assortimento 48 utensili,
con ganci senza pannello

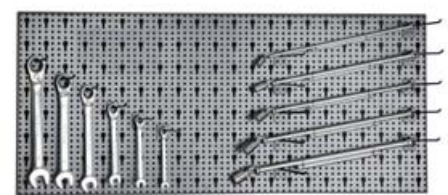

6600 M/44 € 1.250,00 1 066000044

6600 M/47

assortimento 65 utensili,
con ganci senza pannello



6600 M/47 € 1.325,00 1 066000047

6600 M/51

assortimento di 257 utensili
con ganci senza pannello



6600 M/51 € 2.345,00 1 066000051

6600 M/52

assortimento di 176 utensili
con ganci senza pannello



6600 M/52 € 1.530,00 1 066000052

6600 M/58

assortimento di 150 utensili
con ganci senza pannello



6600 M/58 € 1.670,00 1 066000058

6600 M/59

assortimento 220 utensili,
con ganci senza pannello



6600 M/59 € 1.760,00 1 066000059

6600 M/61

assortimento 71 utensili,
con ganci senza pannello



6600 M/61 € 2.135,00 1 066000061

6600 M/62

assortimento 28 utensili,
con ganci senza pannello



6600 M/62 € 499,00 1 066000062

6600 M/63

assortimento di 110 utensili
con ganci senza pannello

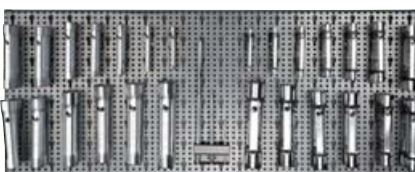

6600 M/63 € 1.930,00 1 066000063

6600 M/73

assortimento di 68 utensili
con ganci senza pannello



6600 M/73 € 1.260,00 1 066000073

6600 M/112

assortimento 329 utensili,
con ganci senza pannello



6600 M/112 € 2.160,00 1 066000112

6600 M/116

assortimento 306 utensili,
con ganci senza pannello



6600 M/116 € 2.020,00 1 066000116

6600 M/120

assortimento 163 utensili,
con ganci senza pannello

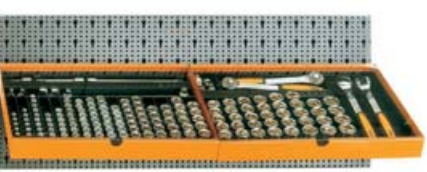

6600 M/120 € 1.490,00 1 066000120

6600 M/125

assortimento 133 utensili,
con ganci senza pannello



6600 M/125 € 1.280,00 1 066000125

6600 M/126

assortimento 58 utensili,
con ganci senza pannello



6600 M/126 € 777,00 1 066000126

6600 M/131

assortimento 92 utensili,
con ganci senza pannello



6600 M/131 € 2.445,00 1 066000131

6600 M/174

assortimento 13 utensili, con ganci senza
pannello



6600 M/174 € 3.510,00 1 066000174

6600 M/175

assortimento 12 utensili,
con ganci senza pannello



6600 M/175 € 2.495,00 1 066000175

6600 M/217

assortimento di 74 utensili
con ganci senza pannello



6600 M/217 € 2.230,00 1 066000217

6600 M/218

assortimento 58 utensili,
con ganci senza pannello

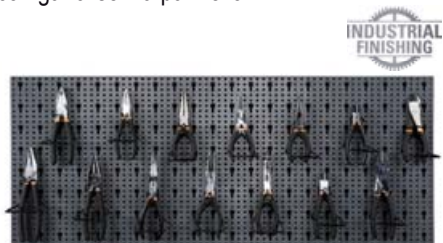

6600 M/218 € 1.170,00 1 066000218

6600 M/222

assortimento di 74 utensili,
con ganci senza pannello



6600 M/222 € 1.800,00 1 066000222

6600 M/223

assortimento 58 utensili,
con ganci senza pannello



6600 M/223 € 1.530,00 1 066000223

6600 M/230

assortimento 78 utensili,
con ganci senza pannello



6600 M/230 € 1.975,00 1 066000230

6600 M/236

assortimento 31 utensili,
con ganci senza pannello



6600 M/236 € 1.115,00 1 066000236

6600 M/241

assortimento di 43 utensili,
con ganci senza pannello



6600 M/241 € 951,00 1 066000241

6600 M/242

assortimento di 91 utensili
con ganci senza pannello



6600 M/242 € 2.300,00 1 066000242

6600 M/253

assortimento 60 utensili,
con ganci senza pannello



6600 M/253 € 1.635,00 1 066000253

6600 M/311

assortimento 114 utensili,
con ganci senza pannello



6600 M/311 € 943,00 1 066000311

6600 M/315

assortimento 149 utensili,
con ganci senza pannello



6600 M/315 € 1.550,00 1 066000315

6600 M/320

assortimento 98 utensili,
con ganci senza pannello

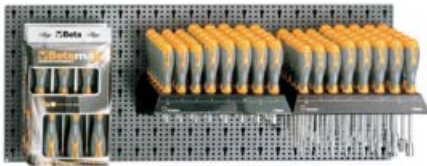

6600 M/320 € 1.445,00 1 066000320

6600 M/326

assortimento 155 utensili,
con ganci senza pannello



6600 M/326 € 1.122,00 1 066000326

6600 M/327

assortimento 101 utensili,
con ganci senza pannello



6600 M/327 € 918,00 1 066000327

6600 M/330

assortimento 110 utensili,
con ganci senza pannello



6600 M/330 € 756,00 1 066000330

6600 M/371

assortimento 162 utensili,
con ganci senza pannello



6600 M/371 € 937,00 1 066000371

6600 M/379

assortimento 69 utensili,
con ganci senza pannello



6600 M/379 € 550,00 1 066000379

6600 M/406

assortimento 107 utensili,
con ganci senza pannello



6600 M/406 € 991,00 1 066000406

6600 M/417

assortimento 43 utensili,
con ganci senza pannello



6600 M/417 € 850,00 1 066000417

6600 M/423

assortimento 29 utensili, con ganci senza
pannello



6600 M/423 € 854,00 1 066000423

6600 M/424

assortimento 36 utensili, con ganci senza
pannello



6600 M/424 € 900,00 1 066000424

6600 M/427

assortimento 24 utensili,
con ganci senza pannello



6600 M/427 € 913,00 1 066000427

6600 M/430

assortimento 29 utensili,
con ganci senza pannello



6600 M/430 € 896,00 1 066000430

6600 M/440

assortimento 140 utensili,
con ganci senza pannello

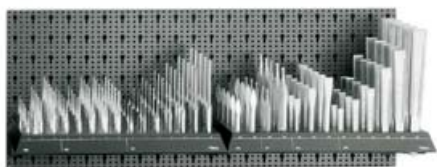

6600 M/440 € 1.705,00 1 066000440

6600 M/456

assortimento di 41 utensili,
con ganci senza pannello



6600 M/456 € 1.400,00 1 066000456

6600 M/465

assortimento 36 utensili, con ganci senza
pannello



6600 M/465 € 1.765,00 1 066000465

6600 M/480

assortimento 18 utensili,
con ganci senza pannello



6600 M/480 € 1.018,00 1 066000480

6600 M/485

assortimento 12 utensili,
con ganci senza pannello



6600 M/485 € 731,00 1 066000485

6600 M/510

assortimento 16 utensili,
con ganci senza pannello



6600 M/510 € 974,00 1 066000510

6600 M/532

assortimento di 24 utensili
con ganci senza pannello



6600 M/532 € 799,00 1 066000532

6600 M/534

assortimento 51 utensili,
con ganci senza pannello



6600 M/534 € 1.280,00 1 066000534

6600 M/542

assortimento di 53 utensili,
con ganci senza pannello



6600 M/542 € 787,00 1 066000542

6600 M/548

assortimento di 37 utensili,
con ganci senza pannello



6600 M/548 € 724,00 1 066000548

6600 M/561

assortimento 60 utensili,
con ganci senza pannello



6600 M/561 € 1.042,00 1 066000561

6600 M/583

assortimento di 22 utensili
con ganci senza pannello



6600 M/583 € 771,00 1 066000583

6600 M/640

assortimento 90 utensili,
con ganci senza pannello



6600 M/640 € 1.650,00 1 066000640

6600 M/650

assortimento 28 utensili,
con ganci senza pannello



6600 M/650 € 2.125,00 1 066000650

6600 M/657

assortimento 17 utensili,
con ganci senza pannello



6600 M/657 € 1.720,00 1 066000657

6600 M/658

assortimento di 14 utensili
con ganci senza pannello

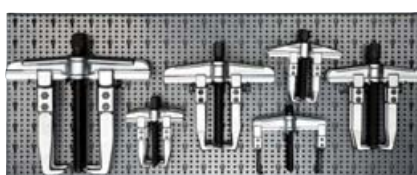

6600 M/658 € 1.925,00 1 066000658

6600 M/716

assortimento 64 utensili,
con ganci senza pannello



6600 M/716 € 2.240,00 1 066000716

6600 M/813

assortimento 25 utensili, con ganci senza
pannello



6600 M/813 € 982,00 1 066000813

6600 M/842

assortimento 36 utensili, con ganci senza
pannello



6600 M/842 € 1.285,00 1 066000842

6600 M/852

assortimento di 560 dischi abrasivi rigidi
con ganci senza pannello



6600 M/852 € 976,00 1 066000852

6600 M/856

assortimento di 560 dischi abrasivi rigidi
con ganci senza pannello



6600 M/856 € 1.027,00 1 066000856

6600 M/857

assortimento di 560 dischi abrasivi rigidi
con ganci senza pannello



6600 M/857 € 1.029,00 1 066000857

6600 M/871

assortimento di 120 dischi abrasivi lamellari
con ganci senza pannello



6600 M/871 € 486,00 1 066000871

6600 M/878

assortimento di 100 dischi abrasivi lamellari
con ganci senza pannello



6600 M/878 € 448,00 1 066000878

6600 M/881

assortimento di 410 ruote abrasive con gambo con vasca espositiva



6600 M/881 € 1.475,00 1 066000881



8600 R/11

assortimento 374 accessori per funi, con ganci senza pannello



8600 R/11 € 1.275,00 1 086000011

8600 R/12

assortimento 259 accessori per funi, con ganci senza pannello

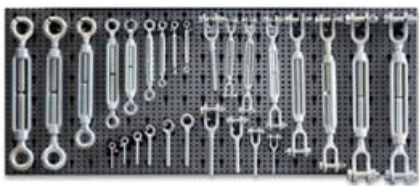

8600 R/12 € 1.295,00 1 086000012

8600 R/13

assortimento 230 accessori per funi, con ganci senza pannello



8600 R/13 € 1.079,00 1 086000013

8600 R/113

assortimento 1862 accessori per funi, con ganci senza pannello



8600 R/113 € 1.465,00 1 086000113

8600 R/114

assortimento 1045 accessori per funi, con ganci senza pannello



8600 R/114 € 1.465,00 1 086000114

8600 R/225

assortimento 64 accessori GRADO 8 con ganci senza pannello



8600 R/225 € 1.060,00 1 086000225

8600 R/412

assortimento 348 accessori INOX per funi, con ganci senza pannello



8600 R/412 € 1.480,00 1 086000412

8600 R/511

assortimento 11 bobine catena genovese con vasca espositiva

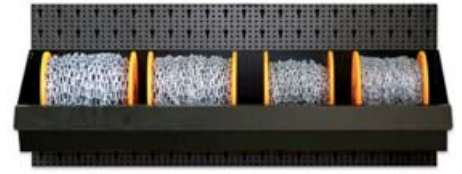

8600 R/511 € 1.210,00 1 086000511

8600 R/601

assortimento 50 cricchetti di ancoraggio con griglie, ripiano e ganci senza pannello



8600 R/601 € 1.220,00 1 086000601
C88/R601 € 252,00 1 088000160

8600 R/611

assortimento 52 fasce di sollevamento con griglie, senza pannello



8600 R/611 € 1.021,00 1 086000611
C88/R611 € 158,00 1 088000161





CALZATURE ANTINFORTUNISTICHE

NORME E CATEGORIE

AVVERTENZE

Verificare prima dell'impiego che la calzatura corrisponda alle proprie esigenze di utilizzo e che la categoria di protezione sia corretta in funzione al tipo e al luogo di lavoro. Le calzature prodotte da Beta Utensili sono conformi alle **NORMATIVE EUROPEE** vigenti. La legge responsabilizza il datore di lavoro per quanto riguarda l'adeguatezza del DPI al tipo di rischio presente (caratteristica del DPI e categoria di appartenenza).

NORMATIVE EUROPEE E RELATIVO SIGNIFICATO

CONFORMITÀ ALLA NORMATIVA EN ISO 20344:2011

La norma specifica i metodi di prova per le calzature progettate come DPI.

CONFORMITÀ ALLA NORMATIVA EN ISO 20345:2011

La norma specifica i requisiti di base e supplementari (facoltativi) per le **calzature di Sicurezza** per usi generali. Le calzature conformi alla normativa EN ISO 20345:2011 sono contraddistinte dalla lettera **"S"** (Safety = Sicurezza) con resistenza del puntale a 200 Joule .

CONFORMITÀ ALLA NORMATIVA EN ISO 20346:2014

La norma specifica i requisiti di base e supplementari (facoltativi) per le **calzature di Protezione**. Le calzature conformi alla normativa EN ISO 20346:2011 sono contraddistinte dalla lettera **"P"** (Protective = Protezione), con resistenza del puntale a 100 Joule.

CONFORMITÀ ALLA NORMATIVA EN ISO 20347:2012

La norma specifica i requisiti di base e supplementari (facoltativi) per le **calzature da lavoro che non sono esposte a rischi meccanici** (urto o compressione). Le calzature conformi alla normativa EN ISO 20347:2012 sono contraddistinte dalla lettera **"O"** (Occupational = Professionale). Sono simili per caratteristiche alle calzature precedentemente indicate, le uniche differenze sono la mancanza del puntale di protezione e della lamina antiperforazione.

Oltre ai requisiti di base obbligatori secondo la norma EN ISO 20345:2011, le calzature possono soddisfare anche **requisiti aggiuntivi**. Tali requisiti devono essere identificati con simboli o classi e indicati sull'etichetta applicata alla linguetta della calzatura.

MARCATURA DI CONFORMITÀ DELLA CALZATURA

- Marchio: CE
- Misura della calzatura: 42
- Nome e indirizzo del fabbricante: Beta Utensili S.p.A. Via Volta, 18 20845 Sovico (MB)
- Mese e anno di produzione: 01/20
- Riferimento della normativa internazionale: EN ISO 20345:2011
- Classe di protezione: S3

CLASSIFICAZIONE

I = Calzature di cuoio e altri materiali, escluse quelle di gomma o materiale polimerico

II = Calzature interamente di gomma o interamente polimeriche (stivali)

CATEGORIA E REQUISITI

SB (I) Requisiti di Base

- Puntale resistente ad **urti** di almeno 200 Joule
- Resistenza allo **scivolamento** della suola secondo almeno uno dei due requisiti SRA e SRB
- **Altezza** minima della tomaia
- Uno tra i requisiti supplementari calzature

S1 (I) Requisiti di Base integrati da:

- Zona del **tallone** chiusa
- Caratteristiche **antistatiche (A)**
- **Assorbimento di energia** nella zona tallone (E)

S2 (I) Requisiti di S1 integrati da:

- Penetrazione ed **assorbimento di acqua** del tomaia (WRU)

S3 (I) Requisiti di S2 integrati da:

- Resistenza alla **perforazione (P)**
- Suola con **rilievi**

S4 (II) Requisiti SB integrati da:

- Caratteristiche **antistatiche (A)**
- **Assorbimento di energia** nella zona tallone (E)

S5 (II) Requisiti S4 integrati da:

- Resistenza alla **perforazione (P)**
- Suola con **rilievi**

REQUISITI BASE + REQUISITI SUPPLEMENTARI CALZATURE

CLASSE DI PROTEZIONE	EN ISO 20345:2011				EN ISO 20347:2012				EN ISO 20345:2011		EN ISO 20347:2012		VALORI MINIMI RICHIESTI	
	SB	S1	S2	S3	0B	01	02	03	S4	S5	04	05		
	Zona del tallone chiusa	O	X	X	X	O	X	X	X	X	X	X	X	
	Resistenza all'urto del puntale 200 Joule	X	X	X	X	-	-	-	-	X	X	-	-	
A	Calzatura antistatica	O	X	X	X	O	X	X	X	X	X	X	X	Resistenza elettrica > 100 kΩ, ≤ 1000 MΩ
E	Assorbimento di energia nella zona tallone	O	X	X	X	O	X	X	X	X	X	X	X	> 20 Joule
WRU	Penetrazione e assorbimento dell'acqua nel tomaio	O	-	X	X	O	-	X	X	-	-	-	-	Penetrazione: < 0.2 g x 60 min Assorbimento: < 30% x 60 min.
P	Resistenza della suola alla perforazione	O	O	-	X	O	O	-	X	O	X	O	X	> 1100 N
CI	Isolamento dal freddo	O	O	O	O	O	O	O	O	O	O	O	O	Riduzione temp. superficie interna suola: < 10° C
HI	Isolamento dal calore	O	O	O	O	O	O	O	O	O	O	O	O	Aumento temp. superficie interna suola: < 22° C
C	Calzatura conduttiva	O	-	-	-	O	-	-	-	-	-	-	-	< 100 kΩ
HRO	Resistenza della suola al calore per contatto	O	O	O	O	O	O	O	O	O	O	O	O	Resistente fino a 300°
AN	Protezione del malleolo	O	O	O	O	O	O	O	O	O	O	O	O	Valore medio < 10 kN; Valori singoli < 15 kN
I	Calzatura elettricamente isolata	O	-	-	-	O	-	-	-	-	-	-	-	Classe elettrica: 00 ÷ 500 V a.c. Classe elettrica: 0 ÷ 1000 V a.
WR	Calzatura resistente all'acqua	O	O	O	O	O	O	O	O	-	-	-	-	Assorbimento: < 3 cm ²
M	Protezione metatarsale (solo per EN ISO 20345:2011)	O	O	O	O	-	-	-	-	O	O	-	-	L'altezza libera al momento dell'urto ≥ 40 mm. (Mis.41/42)
CR	Resistenza al taglio del tomaio (solo per EN ISO 20345:2011). Non deve essere del modello A	O	O	O	O	-	-	-	-	O	O	-	-	Indice di protezione al taglio ≥ 2,5
FO	Resistenza della suola agli idrocarburi	O	X	X	X	O	O	O	O	X	X	O	O	Aumento volume della suola < 12%
WG	Protezione da spruzzi di metallo fuso da operazioni di saldatura	-	-	-	-	-	-	-	-	-	-	-	-	Minimo 25 gocce per arrivare a una temperatura di 40° C
SRC	Resistenza della suola allo scivolamento	X	X	X	X	X	X	X	X					Requisito SRA + SRB

X	Requisito obbligatorio della categoria di protezione
O	Requisito facoltativo unito a quelli obbligatori, se indicato nella marcatura
-	Requisito non obbligatorio , controllare marcatura scarpa

Calzature antistatiche:

Le calzature antistatiche vanno utilizzate quando sussiste la necessità di ridurre al minimo l'accumulo di cariche elettrostatiche in modo da escludere il pericolo di combustione di sostanze infiammabili e vapori e nel caso in cui persista il rischio di scosse elettriche provenienti da elementi sotto tensione. Le calzature antistatiche non forniscono una protezione contro lo shock elettrico in quanto creano unicamente una resistenza elettrica tra il pavimento e il piede. Qualora non si possa escludere completamente il pericolo di uno shock elettrico, si dovrà ricorrere a precauzioni aggiuntive che dovrebbero fare parte di un programma periodico di prevenzione degli infortuni sul posto di lavoro. Al fine di preservare i requisiti di antistaticità, le calzature non dovranno subire modifiche.

Calzature elettricamente isolanti:

Le calzature elettricamente isolate forniscono protezione limitata elettrica da contatti accidentali con tensioni fino a 1000 V con la riserva

che le condizioni di impiego dovranno essere tali da non modificare o alterare la resistenza elettrica con l'influenza dell'umidità. Va specificato che la resistenza elettrica è riferita solamente al fondo della calzatura e non al tomaio.

Classi elettriche calzature:

Classe 00 500V CA oppure 750V CC

Classe 0 1000V CA oppure 1500V CC

Calzature dissipative per ambienti EPA:

Le calzature dissipative sono specifiche per ambienti EPA (ESDS) e permettono alle cariche elettrostatiche presenti sul corpo di chi le indossa di essere dissipate in modo continuo e controllato, in modo da proteggere i componenti e i dispositivi elettronici dai fenomeni elettrostatici. Il valore di riferimento della resistenza al suolo secondo CEI EN 61340-5-1: 2016, per chi lo indossa / calzature / pavimento, è tra < 1 × 10⁹ Ω.

EN ISO 20345:2011		S1P SRC										
LINEA	ARTICOLO	REQUISITI				SETTORI CONSIGLIATI						
		REQUISITI SUPPLEMENTARI			AUTOMOTIVE	EDILIZIA	ELETTRICITA'	INDUSTRIA	LOGISTICA SERVIZI	TERMOIDRAULICA		
BASIC PLUS 	7210BKK				X	X	X	X	X	X	X	564
	7216BKK				X	X	X	X	X	X	X	565
FLEX 	7212FG				X	X	X	X	X	X	X	561
	7213FG				X	X	X	X	X	X	X	562
FLEX LADY 	7212LG				X	X	X	X	X	X	X	561
FLEX EVOLUTION 	7217FB				X	X	X	X	X	X	X	563
	7217FG				X	X	X	X	X	X	X	563
EASY PLUS 	7223PEK				X	X	X	X	X	X	X	560
	7224PEK				X	X	X	X	X	X	X	561
BASIC 	7241BK				X	X	X	X	X	X	X	557
	7243BK				X	X	X	X	X	X	X	557
	7246BK				X	X	X	X	X	X	X	559
	7247BK				X	X	X	X	X	X	X	559
EASY 	7246E				X	X	X	X	X	X	X	556
TREKKING 	7248GK				X	X	X	X	X	X	X	566
	7249GK	RS			X	X	X	X	X	X	X	566
SNEAKERS 	7314AB				X	X	X	X	X	X	X	568
	7314AF				X	X	X	X	X	X	X	567
	7317NA				X	X	X	X	X	X	X	568
SNEAKERS PRO 	7340B				X	X	X	X	X	X	X	572
	7340R				X	X	X	X	X	X	X	572
MANAGER 	7319ESD	ESD	X	X	X	X	X	X	X	X	X	574
0-GRAVITY 	7352A	HRO	X	X	X	X	X	X	X	X	X	570
	7352B	HRO	X	X	X	X	X	X	X	X	X	570
	7353Y	HRO	X	X	X	X	X	X	X	X	X	570

EN ISO 20347:2012		O1 SRC										
LINEA	ARTICOLO	REQUISITI				SETTORI CONSIGLIATI						
0-GRAVITY 	7362B	FO HRO	X	X	X	X	X	X	X	X	X	571



EN ISO 20345:2011		S3 SRC											
LINEA	ARTICOLO	REQUISITI				SETTORI CONSIGLIATI							
		REQUISITI SUPPLEMENTARI			AGRICOLTURA	AUTOMOTIVE	EDILIZIA	INDUSTRIA	ELETTRICITA'	LOGISTICA SERVIZI	OIL & GAS	TERMOIDRAULICA	
BASIC PLUS 	7200BKK				X	X	X	X	X	X	X	X	564
	7201BKK				X	X	X	X	X	X	X	X	564
	7310CRK	RS HRO				X	X	X	X	X	X	X	565
FLEX 	7214FN				X	X	X	X	X	X	X	X	562
	7215FN				X	X	X	X	X	X	X	X	562
	7218FN	RS				X	X	X	X	X	X	X	563
FLEX LADY 	7214LN				X	X	X	X	X	X	X	X	562
FLEX EVOLUTION 	7219FY				X	X	X	X	X	X	X	X	563
EASY PLUS 	7220PEK				X	X	X	X	X	X	X	X	560
	7221PEK	RS			X	X	X	X	X	X	X	X	560
TREKKING 	7235BK				X	X	X	X	X	X	X	X	565
	7236BK	RS			X	X	X	X	X	X	X	X	566
	7238WR	RS HRO WR			X	X	X	X	X	X	X	X	566
EASY 	7241EN				X	X	X	X	X	X	X	X	556
	7243EN	RS			X	X	X	X	X	X	X	X	556
BASIC 	7241CK				X	X	X	X	X	X	X	X	557
	7243CK	RS			X	X	X	X	X	X	X	X	558
	7243CR	RS HRO			X	X	X	X	X	X	X	X	558
	7245BK	RS			X	X	X	X	X	X	X	X	558
SNEAKERS 	7252NKK				X	X	X	X	X	X	X	X	567
	7253NKK				X	X	X	X	X	X	X	X	567
HEAVY DUTY 	7293HM	HRO HI	X		X	X	X	X	X	X	X	X	574
	7293HN	HRO HI	X		X	X	X	X	X	X	X	X	575
	7294HM	HRO HI	X		X	X	X	X	X	X	X	X	575
	7294HMC	HRO HI CI WR	X		X	X	X	X	X	X	X	X	575
	7294HN	RS HRO HI	X		X	X	X	X	X	X	X	X	575
MANAGER 	7300MK		X	X	X	X	X	X	X	X	X	X	573
SNEAKERS 	7315AN		X		X	X	X	X	X	X	X	X	569
	7318AN		X		X	X	X	X	X	X	X	X	569
	7320NA		X	X	X	X	X	X	X	X	X	X	568
	7321NA	RS	X	X	X	X	X	X	X	X	X	X	568
SNEAKERS PRO 	7341N				X	X	X	X	X	X	X	X	572
	7349RP	HRO	X		X	X	X	X	X	X	X	X	573
	7350RP	HRO	X		X	X	X	X	X	X	X	X	573
0-GRAVITY 	7354N	HRO	X		X	X	X	X	X	X	X	X	571
	7355V	HRO	X		X	X	X	X	X	X	X	X	571
	7356G	HRO	X		X	X	X	X	X	X	X	X	569
	7357G	HRO	X		X	X	X	X	X	X	X	X	570

EN ISO 20347:2012		O2 SRC											
LINEA	ARTICOLO	REQUISITI				SETTORI CONSIGLIATI							
BASIC 	7243FT	FO			X	X	X	X	X	X	X	X	558
MANAGER 	7300FT	FO	X	X	X	X	X	X	X	X	X	X	574
0-GRAVITY 	7363N	FO HRO	X		X	X	X	X	X	X	X	X	571

EN ISO 20345:2011		S5 SRC											
LINEA	ARTICOLO	REQUISITI				SETTORI CONSIGLIATI							
BASIC 	7328EA				X	X	X	X	X	X	X	X	559
	7328EN				X	X	X	X	X	X	X	X	559

EASY



7241EN

scarpe in pelle idrorepellente

- Punta in acciaio
- Lamina antiperforazione in acciaio elastico

**EN ISO
20345
2011**



EU	UK	€		
35	2,5	33,00	1	072410835
36	3,5	33,00	1	072410836
37	4,5	33,00	1	072410837
38	5	33,00	1	072410838
39	6	33,00	1	072410839
40	6,5	33,00	1	072410840
41	7	33,00	1	072410841
42	8	33,00	1	072410842
43	9	33,00	1	072410843
44	10	33,00	1	072410844
45	10,5	33,00	1	072410845
46	11	33,00	1	072410846
47	12	33,00	1	072410847
48	13	33,00	1	072410848



CE

S3 SRC

7243EN

scarpe alte in pelle idrorepellente
con rapido sfilamento

- Punta in acciaio
- Lamina antiperforazione in acciaio elastico

**EN ISO
20345
2011**



EU	UK	€		
35	2,5	34,00	1	072430835
36	3,5	34,00	1	072430836
37	4,5	34,00	1	072430837
38	5	34,00	1	072430838
39	6	34,00	1	072430839
40	6,5	34,00	1	072430840
41	7	34,00	1	072430841
42	8	34,00	1	072430842
43	9	34,00	1	072430843
44	10	34,00	1	072430844
45	10,5	34,00	1	072430845
46	11	34,00	1	072430846
47	12	34,00	1	072430847
48	13	34,00	1	072430848



CE

S3 RS SRC

7246E

scarpe basse in pelle scamosciata traforata

- Punta in acciaio
- Lamina antiperforazione in acciaio elastico

**EN ISO
20345
2011**



EU	UK	€		
35	2,5	34,00	1	072460435
36	3,5	34,00	1	072460436
37	4,5	34,00	1	072460437
38	5	34,00	1	072460438
39	6	34,00	1	072460439
40	6,5	34,00	1	072460440
41	7	34,00	1	072460441
42	8	34,00	1	072460442
43	9	34,00	1	072460443
44	10	34,00	1	072460444
45	10,5	34,00	1	072460445
46	11	34,00	1	072460446
47	12	34,00	1	072460447
48	13	34,00	1	072460448



CE

S1P SRC

BASIC



7241BK

scarpe in pelle

- Punta in acciaio
- Lamina antiperforazione in fibra composita

EU	UK	€		
35	2,5	39,50	1	072411235
36	3,5	39,50	1	072411236
37	4,5	39,50	1	072411237
38	5	39,50	1	072411238
39	6	39,50	1	072411239
40	6,5	39,50	1	072411240
41	7	39,50	1	072411241
42	8	39,50	1	072411242
43	9	39,50	1	072411243
44	10	39,50	1	072411244
45	10,5	39,50	1	072411245
46	11	39,50	1	072411246
47	12	39,50	1	072411247
48	13	39,50	1	072411248



CE

S1P SRC

EN ISO
20345
2011



7241CK

scarpe in pelle idrorepellente

- Punta in acciaio
- Lamina antiperforazione in fibra composita

EU	UK	€		
35	2,5	40,50	1	072411535
36	3,5	40,50	1	072411536
37	4,5	40,50	1	072411537
38	5	40,50	1	072411538
39	6	40,50	1	072411539
40	6,5	40,50	1	072411540
41	7	40,50	1	072411541
42	8	40,50	1	072411542
43	9	40,50	1	072411543
44	10	40,50	1	072411544
45	10,5	40,50	1	072411545
46	11	40,50	1	072411546
47	12	40,50	1	072411547
48	13	40,50	1	072411548



CE

S3 SRC

EN ISO
20345
2011



7243BK

scarpe alte in pelle

- Punta in acciaio
- Lamina antiperforazione in fibra composita

EU	UK	€		
35	2,5	40,50	1	072431235
36	3,5	40,50	1	072431236
37	4,5	40,50	1	072431237
38	5	40,50	1	072431238
39	6	40,50	1	072431239
40	6,5	40,50	1	072431240
41	7	40,50	1	072431241
42	8	40,50	1	072431242
43	9	40,50	1	072431243
44	10	40,50	1	072431244
45	10,5	40,50	1	072431245
46	11	40,50	1	072431246
47	12	40,50	1	072431247
48	13	40,50	1	072431248



CE

S1P SRC

EN ISO
20345
2011



7243CK

scarpe alte in pelle idrorepellente
con rapido sfilamento

- Punta in acciaio
- Lamina antiperforazione in fibra composita

EU	UK	€		
35	2,5	41,50	1	072431335
36	3,5	41,50	1	072431336
37	4,5	41,50	1	072431337
38	5	41,50	1	072431338
39	6	41,50	1	072431339
40	6,5	41,50	1	072431340
41	7	41,50	1	072431341
42	8	41,50	1	072431342
43	9	41,50	1	072431343
44	10	41,50	1	072431344
45	10,5	41,50	1	072431345
46	11	41,50	1	072431346
47	12	41,50	1	072431347
48	13	41,50	1	072431348



CE

S3 RS SRC



7243CR

scarpe alte in pelle idrorepellente
con suola in gomma ad alta resistenza
e rapido sfilamento

- Punta in acciaio
- Lamina antiperforazione in acciaio elastico

EU	UK	€		
35	2,5	61,00	1	072430735
36	3,5	61,00	1	072430736
37	4,5	61,00	1	072430737
38	5	61,00	1	072430738
39	6	61,00	1	072430739
40	6,5	61,00	1	072430740
41	7	61,00	1	072430741
42	8	61,00	1	072430742
43	9	61,00	1	072430743
44	10	61,00	1	072430744
45	10,5	61,00	1	072430745
46	11	61,00	1	072430746
47	12	61,00	1	072430747
48	13	61,00	1	072430748



CE

S3 RS HRO SRC



7243FT

scarpe alte in pelle idrorepellente
senza punta e lamina antiperforazione

- Senza punta
- Senza lamina antiperforazione

EU	UK	€		
35	2,5	36,00	1	072430635
36	3,5	36,00	1	072430636
37	4,5	36,00	1	072430637
38	5	36,00	1	072430638
39	6	36,00	1	072430639
40	6,5	36,00	1	072430640
41	7	36,00	1	072430641
42	8	36,00	1	072430642
43	9	36,00	1	072430643
44	10	36,00	1	072430644
45	10,5	36,00	1	072430645
46	11	36,00	1	072430646
47	12	36,00	1	072430647
48	13	36,00	1	072430648



CE

O2 FO SRC



7245BK

scarpe alte "saldatore" stringate in pelle idrorepellente con
rapido sfilamento
e protezione frontale con chiusura a strappo

- Punta in acciaio
- Lamina antiperforazione in fibra composita

EU	UK	€		
35	2,5	48,00	1	072451235
36	3,5	48,00	1	072451236
37	4,5	48,00	1	072451237
38	5	48,00	1	072451238
39	6	48,00	1	072451239
40	6,5	48,00	1	072451240
41	7	48,00	1	072451241
42	8	48,00	1	072451242
43	9	48,00	1	072451243
44	10	48,00	1	072451244
45	10,5	48,00	1	072451245
46	11	48,00	1	072451246
47	12	48,00	1	072451247
48	13	48,00	1	072451248



CE

S3 RS SRC



7246BK

scarpe in pelle scamosciata traforata

- Puntale in acciaio
- Lamina antiperforazione in fibra composita

EU	UK	€		
35	2,5	41,50	1	072461235
36	3,5	41,50	1	072461236
37	4,5	41,50	1	072461237
38	5	41,50	1	072461238
39	6	41,50	1	072461239
40	6,5	41,50	1	072461240
41	7	41,50	1	072461241
42	8	41,50	1	072461242
43	9	41,50	1	072461243
44	10	41,50	1	072461244
45	10,5	41,50	1	072461245
46	11	41,50	1	072461246
47	12	41,50	1	072461247
48	13	41,50	1	072461248



CE

S1P SRC

EN ISO 20345 2011



7247BK

sandali in pelle traforata

- Puntale in acciaio
- Lamina antiperforazione in fibra composita

EU	UK	€		
35	2,5	41,00	1	072471235
36	3,5	41,00	1	072471236
37	4,5	41,00	1	072471237
38	5	41,00	1	072471238
39	6	41,00	1	072471239
40	6,5	41,00	1	072471240
41	7	41,00	1	072471241
42	8	41,00	1	072471242
43	9	41,00	1	072471243
44	10	41,00	1	072471244
45	10,5	41,00	1	072471245
46	11	41,00	1	072471246
47	12	41,00	1	072471247
48	13	41,00	1	072471248



CE

S1P SRC

EN ISO 20345 2011



7328EA

stivali di sicurezza "alta visibilità"

- Puntale in acciaio
- Lamina antiperforazione in acciaio elastico

EU	UK	€		
38	5	34,00	1	073280538
39	6	34,00	1	073280539
40	6,5	34,00	1	073280540
41	7	34,00	1	073280541
42	8	34,00	1	073280542
43	9	34,00	1	073280543
44	10	34,00	1	073280544
45	10,5	34,00	1	073280545
46	11	34,00	1	073280546
47	12	34,00	1	073280547



CE

S5 SRC

EN ISO 20345 2011



7328EN

stivali di sicurezza

- Puntale in acciaio
- Lamina antiperforazione in acciaio elastico

EU	UK	€		
38	5	34,00	1	073280738
39	6	34,00	1	073280739
40	6,5	34,00	1	073280740
41	7	34,00	1	073280741
42	8	34,00	1	073280742
43	9	34,00	1	073280743
44	10	34,00	1	073280744
45	10,5	34,00	1	073280745
46	11	34,00	1	073280746
47	12	34,00	1	073280747



CE

S5 SRC

EN ISO 20345 2011



EASY PLUS



7220PEK

scarpe in pelle idrorepellente con inserti in nylon e rinforzo antiabrasione nella zona del puntale

- Puntale in composito
- Lamina antiperforazione in fibra composita

EU	UK	€		
35	2,5	54,50	1	072200235
36	3,5	54,50	1	072200236
37	4,5	54,50	1	072200237
38	5	54,50	1	072200238
39	6	54,50	1	072200239
40	6,5	54,50	1	072200240
41	7	54,50	1	072200241
42	8	54,50	1	072200242
43	9	54,50	1	072200243
44	10	54,50	1	072200244
45	10,5	54,50	1	072200245
46	11	54,50	1	072200246
47	12	54,50	1	072200247
48	13	54,50	1	072200248



EN ISO 20345 2011



CE

S3 SRC

7221PEK

scarpe alte in pelle idrorepellente con inserti in nylon, rinforzo antiabrasione nella zona del puntale e rapido sfilamento

- Puntale in composito
- Lamina antiperforazione in fibra composita

EU	UK	€		
35	2,5	56,50	1	072210235
36	3,5	56,50	1	072210236
37	4,5	56,50	1	072210237
38	5	56,50	1	072210238
39	6	56,50	1	072210239
40	6,5	56,50	1	072210240
41	7	56,50	1	072210241
42	8	56,50	1	072210242
43	9	56,50	1	072210243
44	10	56,50	1	072210244
45	10,5	56,50	1	072210245
46	11	56,50	1	072210246
47	12	56,50	1	072210247
48	13	56,50	1	072210248



EN ISO 20345 2011



CE

S3 RS SRC

7223PEK

scarpe in pelle scamosciata con inserti in mesh ad alta traspirazione e rinforzo antiabrasione nella zona del puntale

- Puntale in composito
- Lamina antiperforazione in fibra composita

EU	UK	€		
35	2,5	56,00	1	072230135
36	3,5	56,00	1	072230136
37	4,5	56,00	1	072230137
38	5	56,00	1	072230138
39	6	56,00	1	072230139
40	6,5	56,00	1	072230140
41	7	56,00	1	072230141
42	8	56,00	1	072230142
43	9	56,00	1	072230143
44	10	56,00	1	072230144
45	10,5	56,00	1	072230145
46	11	56,00	1	072230146
47	12	56,00	1	072230147
48	13	56,00	1	072230148



EN ISO 20345 2011



CE

S1P SRC

7224PEK

scarpe in pelle scamosciata traforata con rinforzo antiabrasione nella zona del puntale

- Puntale in composito
- Lamina antiperforazione in fibra composita

EU	UK	€		
35	2,5	56,00	1	072240235
36	3,5	56,00	1	072240236
37	4,5	56,00	1	072240237
38	5	56,00	1	072240238
39	6	56,00	1	072240239
40	6,5	56,00	1	072240240
41	7	56,00	1	072240241
42	8	56,00	1	072240242
43	9	56,00	1	072240243
44	10	56,00	1	072240244
45	10,5	56,00	1	072240245
46	11	56,00	1	072240246
47	12	56,00	1	072240247
48	13	56,00	1	072240248

CE



S1P SRC

EN ISO 20345 2011



FLEX

7212FG

scarpe in pelle scamosciata traforata con inserto antiabrasione nella zona del puntale

Estremamente flessibili e leggere - peso indicativo misura 42: 490 g

Non indicate per impieghi gravosi (edilizia, agricoltura, industria pesante)

- Puntale in composito
- Lamina antiperforazione in fibra composita

EU	UK	€		
35	2,5	60,00	1	072120035
36	3,5	60,00	1	072120036
37	4,5	60,00	1	072120037
38	5	60,00	1	072120038
39	6	60,00	1	072120039
40	6,5	60,00	1	072120040
41	7	60,00	1	072120041
42	8	60,00	1	072120042
43	9	60,00	1	072120043
44	10	60,00	1	072120044
45	10,5	60,00	1	072120045
46	11	60,00	1	072120046
47	12	60,00	1	072120047
48	13	60,00	1	072120048

CE



FLEX



S1P SRC

EN ISO 20345 2011



7212LG

scarpe basse da donna

in pelle scamosciata traforata con inserti in mesh

Estremamente flessibili e leggere - peso indicativo misura 38: 380 g

Non indicate per impieghi gravosi (edilizia, agricoltura, industria pesante)

- Puntale in composito
- Lamina antiperforazione in fibra composita

EU	UK	€		
34	2	57,00	1	072120134
35	2,5	57,00	1	072120135
36	3,5	57,00	1	072120136
37	4,5	57,00	1	072120137
38	5	57,00	1	072120138
39	6	57,00	1	072120139
40	6,5	57,00	1	072120140
41	7	57,00	1	072120141
42	8	57,00	1	072120142

CE



lady



S1P SRC

EN ISO 20345 2011



7213FG

scarpe in pelle scamosciata con inserti in mesh ad alta traspirazione • Puntale in composito
 Estremamente flessibili e leggere - peso indicativo misura 42: **490 g** • Lamina antiperforazione in fibra composita
 Non indicate per impieghi gravosi (edilizia, agricoltura, industria pesante)

EU	UK	€		
35	2,5	60,00	1	072130035
36	3,5	60,00	1	072130036
37	4,5	60,00	1	072130037
38	5	60,00	1	072130038
39	6	60,00	1	072130039
40	6,5	60,00	1	072130040
41	7	60,00	1	072130041
42	8	60,00	1	072130042
43	9	60,00	1	072130043
44	10	60,00	1	072130044
45	10,5	60,00	1	072130045
46	11	60,00	1	072130046
47	12	60,00	1	072130047
48	13	60,00	1	072130048



CE

S1P SRC

EN ISO
20345
2011

7214FN

scarpe in action nabuk idrorepellente con inserto antiabrasione nella zona del puntale Estremamente flessibili e leggere - peso indicativo misura 42: **500 g** Non indicate per impieghi gravosi (edilizia, agricoltura, industria pesante)

EU	UK	€		
35	2,5	65,00	1	072140035
36	3,5	65,00	1	072140036
37	4,5	65,00	1	072140037
38	5	65,00	1	072140038
39	6	65,00	1	072140039
40	6,5	65,00	1	072140040
41	7	65,00	1	072140041
42	8	65,00	1	072140042
43	9	65,00	1	072140043
44	10	65,00	1	072140044
45	10,5	65,00	1	072140045
46	11	65,00	1	072140046
47	12	65,00	1	072140047
48	13	65,00	1	072140048



CE

S3 SRC

EN ISO
20345
2011

7214LN

scarpe basse da donna in pelle scamosciata idrorepellente con inserto antiabrasione nella zona del puntale • Puntale in composito
 Estremamente flessibili e leggere - peso indicativo misura 38: **380 g** • Lamina antiperforazione in fibra composita
 Non indicate per impieghi gravosi (edilizia, agricoltura, industria pesante)

EU	UK	€		
34	2	60,00	1	072140134
35	2,5	60,00	1	072140135
36	3,5	60,00	1	072140136
37	4,5	60,00	1	072140137
38	5	60,00	1	072140138
39	6	60,00	1	072140139
40	6,5	60,00	1	072140140
41	7	60,00	1	072140141
42	8	60,00	1	072140142



CE

S3 SRC

EN ISO
20345
2011

7215FN

mocassini in action nabuk idrorepellente con inserto antiabrasione nella zona del puntale • Puntale in composito
 Estremamente flessibili e leggere - peso indicativo misura 42: **490 g** • Lamina antiperforazione in fibra composita
 Non indicate per impieghi gravosi (edilizia, agricoltura, industria pesante)

EU	UK	€		
35	2,5	66,00	1	072150135
36	3,5	66,00	1	072150136
37	4,5	66,00	1	072150137
38	5	66,00	1	072150138
39	6	66,00	1	072150139
40	6,5	66,00	1	072150140
41	7	66,00	1	072150141
42	8	66,00	1	072150142
43	9	66,00	1	072150143
44	10	66,00	1	072150144
45	10,5	66,00	1	072150145
46	11	66,00	1	072150146
47	12	66,00	1	072150147
48	13	66,00	1	072150148



CE

S3 SRC

EN ISO
20345
2011

7217FB

scarpe in mesh ad alta traspirazione
con inserto antiabrasione nella zona del puntale
estremamente flessibili e leggere - peso indicativo misura 42: **490 g**
non indicate per impieghi gravosi (edilizia, agricoltura, industria pesante)

- Puntale in composito
- Lamina antiperforazione in fibra composita

EU	UK	€		
35	2,5	68,00	1	072170135
36	3,5	68,00	1	072170136
37	4,5	68,00	1	072170137
38	5	68,00	1	072170138
39	6	68,00	1	072170139
40	6,5	68,00	1	072170140
41	7	68,00	1	072170141
42	8	68,00	1	072170142
43	9	68,00	1	072170143
44	10	68,00	1	072170144
45	10,5	68,00	1	072170145
46	11	68,00	1	072170146
47	12	68,00	1	072170147
48	13	68,00	1	072170148



CE

S1P SRC

EN ISO 20345 2011



7217FG

scarpe in mesh ad alta traspirazione
con inserto antiabrasione nella zona del puntale
estremamente flessibili e leggere - peso indicativo misura 42: **490 g**
non indicate per impieghi gravosi (edilizia, agricoltura, industria pesante)

- Puntale in composito
- Lamina antiperforazione in fibra composita

EU	UK	€		
35	2,5	68,00	1	072170235
36	3,5	68,00	1	072170236
37	4,5	68,00	1	072170237
38	5	68,00	1	072170238
39	6	68,00	1	072170239
40	6,5	68,00	1	072170240
41	7	68,00	1	072170241
42	8	68,00	1	072170242
43	9	68,00	1	072170243
44	10	68,00	1	072170244
45	10,5	68,00	1	072170245
46	11	68,00	1	072170246
47	12	68,00	1	072170247
48	13	68,00	1	072170248



S1P SRC

EN ISO 20345 2011



7218FN

scarpe alte in action nabuk idrorepellente con inserto
antiabrasione nella zona del puntale e rapido sfilamento
Estremamente flessibili e leggere - peso indicativo misura 42: **510 g**
Non indicate per impieghi gravosi (edilizia, agricoltura, industria pesante)

- Puntale in composito
- Lamina antiperforazione in fibra composita

EU	UK	€		
35	2,5	68,00	1	072180035
36	3,5	68,00	1	072180036
37	4,5	68,00	1	072180037
38	5	68,00	1	072180038
39	6	68,00	1	072180039
40	6,5	68,00	1	072180040
41	7	68,00	1	072180041
42	8	68,00	1	072180042
43	9	68,00	1	072180043
44	10	68,00	1	072180044
45	10,5	68,00	1	072180045
46	11	68,00	1	072180046
47	12	68,00	1	072180047
48	13	68,00	1	072180048



CE

S3 RS SRC

EN ISO 20345 2011



7219FY

scarpe in microfibra idrorepellente con inserto antiabrasione nella zona
del puntale
estremamente flessibili e leggere - peso indicativo misura 42: **490 g**
non indicate per impieghi gravosi (edilizia, agricoltura, industria pesante)

- Puntale in composito
- Lamina antiperforazione in fibra composita

EU	UK	€		
35	2,5	72,00	1	072190035
36	3,5	72,00	1	072190036
37	4,5	72,00	1	072190037
38	5	72,00	1	072190038
39	6	72,00	1	072190039
40	6,5	72,00	1	072190040
41	7	72,00	1	072190041
42	8	72,00	1	072190042
43	9	72,00	1	072190043
44	10	72,00	1	072190044
45	10,5	72,00	1	072190045
46	11	72,00	1	072190046
47	12	72,00	1	072190047
48	13	72,00	1	072190048



CE

S3 SRC

EN ISO 20345 2011



BASIC PLUS



7200BKK

scarpe in pelle pieno fiore idrorepellente

- Puntale in composito
- Lamina antiperforazione in fibra composita

EU	UK	€		
35	2,5	65,00	1	072000235
36	3,5	65,00	1	072000236
37	4,5	65,00	1	072000237
38	5	65,00	1	072000238
39	6	65,00	1	072000239
40	6,5	65,00	1	072000240
41	7	65,00	1	072000241
42	8	65,00	1	072000242
43	9	65,00	1	072000243
44	10	65,00	1	072000244
45	10,5	65,00	1	072000245
46	11	65,00	1	072000246
47	12	65,00	1	072000247
48	13	65,00	1	072000248



CE

S3 SRC

EN ISO 20345 2011



7201BKK

scarpe alte in pelle pieno fiore idrorepellente

- Puntale in composito
- Lamina antiperforazione in fibra composita

EU	UK	€		
35	2,5	68,50	1	072010435
36	3,5	68,50	1	072010436
37	4,5	68,50	1	072010437
38	5	68,50	1	072010438
39	6	68,50	1	072010439
40	6,5	68,50	1	072010440
41	7	68,50	1	072010441
42	8	68,50	1	072010442
43	9	68,50	1	072010443
44	10	68,50	1	072010444
45	10,5	68,50	1	072010445
46	11	68,50	1	072010446
47	12	68,50	1	072010447
48	13	68,50	1	072010448



CE

S3 SRC

EN ISO 20345 2011



7210BKK

scarpe in morbida pelle scamosciata traforata

- Puntale in composito
- Lamina antiperforazione in fibra composita

EU	UK	€		
35	2,5	62,50	1	072100335
36	3,5	62,50	1	072100336
37	4,5	62,50	1	072100337
38	5	62,50	1	072100338
39	6	62,50	1	072100339
40	6,5	62,50	1	072100340
41	7	62,50	1	072100341
42	8	62,50	1	072100342
43	9	62,50	1	072100343
44	10	62,50	1	072100344
45	10,5	62,50	1	072100345
46	11	62,50	1	072100346
47	12	62,50	1	072100347
48	13	62,50	1	072100348



CE

S1P SRC

EN ISO 20345 2011



7216BKK

sandali in morbida pelle scamosciata con chiusura a strappo

- Puntale in composito
- Lamina antiperforazione in fibra composita

EU	UK	€	
35	2,5	65,50	1 072160335
36	3,5	65,50	1 072160336
37	4,5	65,50	1 072160337
38	5	65,50	1 072160338
39	6	65,50	1 072160339
40	6,5	65,50	1 072160340
41	7	65,50	1 072160341
42	8	65,50	1 072160342
43	9	65,50	1 072160343
44	10	65,50	1 072160344
45	10,5	65,50	1 072160345
46	11	65,50	1 072160346
47	12	65,50	1 072160347
48	13	65,50	1 072160348

CE



S1P SRC

EN ISO 20345 2011



7310CRK

scarpe "saldatore" stringate in pelle stampata idrorepellente con rapido sfilamento e protezione frontale con chiusura a strappo e cuciture antifiamma. Suola in gomma ad alta resistenza ed inserto antiabrasione nella zona del puntale

- Puntale in composito
- Lamina antiperforazione in fibra composita

EU	UK	€	
35	2,5	74,00	1 073100335
36	3,5	74,00	1 073100336
37	4,5	74,00	1 073100337
38	5	74,00	1 073100338
39	6	74,00	1 073100339
40	6,5	74,00	1 073100340
41	7	74,00	1 073100341
42	8	74,00	1 073100342
43	9	74,00	1 073100343
44	10	74,00	1 073100344
45	10,5	74,00	1 073100345
46	11	74,00	1 073100346
47	12	74,00	1 073100347
48	13	74,00	1 073100348

CE



S3 RS HRO SRC

EN ISO 20345 2011



TREKKING



7235BK

scarpe basse in action nabuk idrorepellente con copripuntale di rinforzo in poliuretano

- Puntale in acciaio
- Lamina antiperforazione in fibra composita

EU	UK	€	
35	2,5	59,50	1 072350335
36	3,5	59,50	1 072350336
37	4,5	59,50	1 072350337
38	5	59,50	1 072350338
39	6	59,50	1 072350339
40	6,5	59,50	1 072350340
41	7	59,50	1 072350341
42	8	59,50	1 072350342
43	9	59,50	1 072350343
44	10	59,50	1 072350344
45	10,5	59,50	1 072350345
46	11	59,50	1 072350346
47	12	59,50	1 072350347
48	13	59,50	1 072350348

CE



S3 SRC

EN ISO 20345 2011



7236BK

scarpe alte in action nabuk idrorepellente
con rapido sfilamento e copripuntale di rinforzo in poliuretano

- Puntale in acciaio
- Lamina antiperforazione in fibra composita

EU	UK	€		
35	2,5	62,50	1	072360335
36	3,5	62,50	1	072360336
37	4,5	62,50	1	072360337
38	5	62,50	1	072360338
39	6	62,50	1	072360339
40	6,5	62,50	1	072360340
41	7	62,50	1	072360341
42	8	62,50	1	072360342
43	9	62,50	1	072360343
44	10	62,50	1	072360344
45	10,5	62,50	1	072360345
46	11	62,50	1	072360346
47	12	62,50	1	072360347
48	13	62,50	1	072360348

CE



S3 RS SRC

EN ISO
20345
2011



7238WR

scarpe alte in pelle scamosciata con inserti in nylon, suola in gomma ad alta resistenza e rapido sfilamento Calzatura **WR** resistente all'acqua: sottoposta a prova, in una vasca con 3 cm di acqua, dopo 100 lunghezze, l'area totale bagnata all'interno della calzatura non deve superare i 3 cm² (macchia)

- Puntale in composito
- Lamina antiperforazione in fibra composita

EU	UK	€		
35	2,5	83,50	1	072380235
36	3,5	83,50	1	072380236
37	4,5	83,50	1	072380237
38	5	83,50	1	072380238
39	6	83,50	1	072380239
40	6,5	83,50	1	072380240
41	7	83,50	1	072380241
42	8	83,50	1	072380242
43	9	83,50	1	072380243
44	10	83,50	1	072380244
45	10,5	83,50	1	072380245
46	11	83,50	1	072380246
47	12	83,50	1	072380247
48	13	83,50	1	072380248

CE

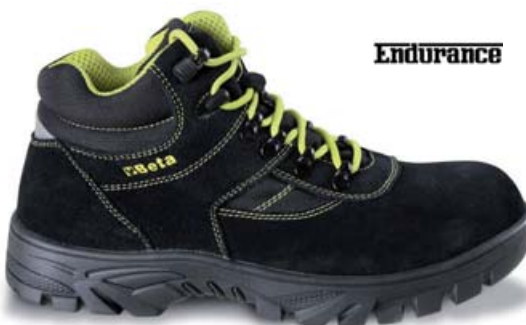

Endurance

S3 RS WR HRO SRC

EN ISO
20345
2011



7248GK

scarpe basse in pelle scamosciata con inserti in nylon e copripuntale di rinforzo in poliuretano

- Puntale in acciaio
- Lamina antiperforazione fibra composita

EU	UK	€		
35	2,5	49,00	1	072480235
36	3,5	49,00	1	072480236
37	4,5	49,00	1	072480237
38	5	49,00	1	072480238
39	6	49,00	1	072480239
40	6,5	49,00	1	072480240
41	7	49,00	1	072480241
42	8	49,00	1	072480242
43	9	49,00	1	072480243
44	10	49,00	1	072480244
45	10,5	49,00	1	072480245
46	11	49,00	1	072480246
47	12	49,00	1	072480247
48	13	49,00	1	072480248

CE



S1P SRC

EN ISO
20345
2011



7249GK

scarpe alte in pelle scamosciata con inserti in nylon, rapido sfilamento e copripuntale di rinforzo in poliuretano

- Puntale in acciaio
- Lamina antiperforazione in fibra composita

EU	UK	€		
35	2,5	52,00	1	072490235
36	3,5	52,00	1	072490236
37	4,5	52,00	1	072490237
38	5	52,00	1	072490238
39	6	52,00	1	072490239
40	6,5	52,00	1	072490240
41	7	52,00	1	072490241
42	8	52,00	1	072490242
43	9	52,00	1	072490243
44	10	52,00	1	072490244
45	10,5	52,00	1	072490245
46	11	52,00	1	072490246
47	12	52,00	1	072490247
48	13	52,00	1	072490248

CE



S1P RS SRC

EN ISO
20345
2011



SNEAKERS



7252NKK

scarpe basse in pelle nabuk idrorepellente con inserti in microfibra idrorepellente

- Puntale in materiale composito
- Lamina antiperforazione in fibra composita

EU	UK	€	Art.
38	5	119,00	1 072520138
39	6	119,00	1 072520139
40	6,5	119,00	1 072520140
41	7	119,00	1 072520141
42	8	119,00	1 072520142
43	9	119,00	1 072520143
44	10	119,00	1 072520144
45	10,5	119,00	1 072520145
46	11	119,00	1 072520146
47	12	119,00	1 072520147

CE

Zolder



S3 SRC

EN ISO 20345 2011



7253NKK

scarpe alte in pelle nabuk idrorepellente con inserti in microfibra idrorepellente

- Puntale in materiale composito
- Lamina antiperforazione in fibra composita

EU	UK	€	Art.
38	5	122,00	1 072530138
39	6	122,00	1 072530139
40	6,5	122,00	1 072530140
41	7	122,00	1 072530141
42	8	122,00	1 072530142
43	9	122,00	1 072530143
44	10	122,00	1 072530144
45	10,5	122,00	1 072530145
46	11	122,00	1 072530146
47	12	122,00	1 072530147

CE

Zolder



S3 SRC

EN ISO 20345 2011



7314AF

scarpe in pelle scamosciata con inserti in nylon mesh e carbon

- Puntale in composito
- Lamina antiperforazione in fibra composita

EU	UK	€	Art.
35	2,5	83,00	1 073140235
36	3,5	83,00	1 073140236
37	4,5	83,00	1 073140237
38	5	83,00	1 073140238
39	6	83,00	1 073140239
40	6,5	83,00	1 073140240
41	7	83,00	1 073140241
42	8	83,00	1 073140242
43	9	83,00	1 073140243
44	10	83,00	1 073140244
45	10,5	83,00	1 073140245
46	11	83,00	1 073140246
47	12	83,00	1 073140247
48	13	83,00	1 073140248

CE

Active



S1P SRC

EN ISO 20345 2011



7314AB

scarpe in pelle scamosciata con inserti in nylon mesh e carbon

- Puntale in composito
- Lamina antiperforazione in fibra composita

EU	UK	€		
35	2,5	83,00	1	073140335
36	3,5	83,00	1	073140336
37	4,5	83,00	1	073140337
38	5	83,00	1	073140338
39	6	83,00	1	073140339
40	6,5	83,00	1	073140340
41	7	83,00	1	073140341
42	8	83,00	1	073140342
43	9	83,00	1	073140343
44	10	83,00	1	073140344
45	10,5	83,00	1	073140345
46	11	83,00	1	073140346
47	12	83,00	1	073140347
48	13	83,00	1	073140348



Active



CE

S1P SRC

EN ISO 20345 2011



7317NA

scarpe in pelle scamosciata traforata con supporto di stabilità al tallone

- Puntale in composito
- Lamina antiperforazione in fibra composita

EU	UK	€		
35	2,5	62,00	1	073170135
36	3,5	62,00	1	073170136
37	4,5	62,00	1	073170137
38	5	62,00	1	073170138
39	6	62,00	1	073170139
40	6,5	62,00	1	073170140
41	7	62,00	1	073170141
42	8	62,00	1	073170142
43	9	62,00	1	073170143
44	10	62,00	1	073170144
45	10,5	62,00	1	073170145
46	11	62,00	1	073170146
47	12	62,00	1	073170147
48	13	62,00	1	073170148



NewActive



CE

S1P SRC

EN ISO 20345 2011



7320NA

scarpe in action nabuk idrorepellente con rinforzo antiabrasione nella zona del puntale e supporto di stabilità al tallone

- Puntale in composito
- Lamina antiperforazione in fibra composita

EU	UK	€		
35	2,5	65,00	1	073200435
36	3,5	65,00	1	073200436
37	4,5	65,00	1	073200437
38	5	65,00	1	073200438
39	6	65,00	1	073200439
40	6,5	65,00	1	073200440
41	7	65,00	1	073200441
42	8	65,00	1	073200442
43	9	65,00	1	073200443
44	10	65,00	1	073200444
45	10,5	65,00	1	073200445
46	11	65,00	1	073200446
47	12	65,00	1	073200447
48	13	65,00	1	073200448



NewActive



CE

S3 SRC

EN ISO 20345 2011



7321NA

scarpe alte in action nabuk idrorepellente con rapido sfilamento, rinforzo antiabrasione nella zona del puntale e supporto di stabilità al tallone

- Puntale in composito
- Lamina antiperforazione in fibra composita

EU	UK	€		
35	2,5	67,00	1	073210435
36	3,5	67,00	1	073210436
37	4,5	67,00	1	073210437
38	5	67,00	1	073210438
39	6	67,00	1	073210439
40	6,5	67,00	1	073210440
41	7	67,00	1	073210441
42	8	67,00	1	073210442
43	9	67,00	1	073210443
44	10	67,00	1	073210444
45	10,5	67,00	1	073210445
46	11	67,00	1	073210446
47	12	67,00	1	073210447
48	13	67,00	1	073210448



NewActive



CE

S3 RS SRC

EN ISO 20345 2011



7315AN

scarpe in pelle scamosciata e microfibra idrorepellenti con inserti in carbon

- Puntale in composito
- Lamina antiperforazione in fibra composita

EU	UK	€		
35	2,5	96,00	1	073150535
36	3,5	96,00	1	073150536
37	4,5	96,00	1	073150537
38	5	96,00	1	073150538
39	6	96,00	1	073150539
40	6,5	96,00	1	073150540
41	7	96,00	1	073150541
42	8	96,00	1	073150542
43	9	96,00	1	073150543
44	10	96,00	1	073150544
45	10,5	96,00	1	073150545
46	11	96,00	1	073150546
47	12	96,00	1	073150547
48	13	96,00	1	073150548



CE

S3 SRC

EN ISO 20345 2011



7318AN

scarpe alte in pelle scamosciata e microfibra idrorepellenti con inserti in carbon

- Puntale in composito
- Lamina antiperforazione in fibra composita

EU	UK	€		
35	2,5	99,00	1	073180535
36	3,5	99,00	1	073180536
37	4,5	99,00	1	073180537
38	5	99,00	1	073180538
39	6	99,00	1	073180539
40	6,5	99,00	1	073180540
41	7	99,00	1	073180541
42	8	99,00	1	073180542
43	9	99,00	1	073180543
44	10	99,00	1	073180544
45	10,5	99,00	1	073180545
46	11	99,00	1	073180546
47	12	99,00	1	073180547
48	13	99,00	1	073180548



CE

S3 SRC

EN ISO 20345 2011



O-GRAVITY



7356G

scarpe in microfibra idrorepellente con inserti in TPU
Supporto di stabilità tallone, collare "slip on" elasticizzato per facilitare la calzata
e suola in EVA con battistrada in gomma nitrilica ad alta resistenza

- Puntale in composito
- Lamina antiperforazione in fibra composita
- **LEGGEREZZA STRAORDINARIA:** peso indicativo misura 42: 460 grammi

EU	UK	€		
38	5	113,00	1	073560038
39	6	113,00	1	073560039
40	6,5	113,00	1	073560040
41	7	113,00	1	073560041
42	8	113,00	1	073560042
43	9	113,00	1	073560043
44	10	113,00	1	073560044
45	10,5	113,00	1	073560045
46	11	113,00	1	073560046
47	12	113,00	1	073560047
48	13	113,00	1	073560048



CE

S3 HRO SRC

EN ISO 20345 2011



7357G

scarpe alte in microfibra idrorepellente con inserti in TPU
Supporto di stabilità tallone, collare elasticizzato per facilitare la calzatura
e suola in EVA con battistrada in gomma nitrilica ad alta resistenza

- Puntale in composito
- Lamina antiperforazione in fibra composita
- **LEGGEREZZA STRAORDINARIA:** peso indicativo misura 42: 480 grammi

EU	UK	€		
38	5	124,00	1	073570038
39	6	124,00	1	073570039
40	6,5	124,00	1	073570040
41	7	124,00	1	073570041
42	8	124,00	1	073570042
43	9	124,00	1	073570043
44	10	124,00	1	073570044
45	10,5	124,00	1	073570045
46	11	124,00	1	073570046
47	12	124,00	1	073570047
48	13	124,00	1	073570048



CE

S3 HRO SRC

EN ISO
20345
2011



7352A

scarpe in tessuto mesh ad alta traspirazione con inserti in TPU
Supporto di stabilità tallone, collare "slip on" elasticizzato per facilitare la calzatura
e suola in EVA con battistrada in gomma nitrilica ad alta resistenza

- Puntale in composito
- Lamina antiperforazione in fibra composita
- **LEGGEREZZA STRAORDINARIA:** peso indicativo misura 42: 450 grammi

EU	UK	€		
38	5	105,00	1	073520038
39	6	105,00	1	073520039
40	6,5	105,00	1	073520040
41	7	105,00	1	073520041
42	8	105,00	1	073520042
43	9	105,00	1	073520043
44	10	105,00	1	073520044
45	10,5	105,00	1	073520045
46	11	105,00	1	073520046
47	12	105,00	1	073520047
48	13	105,00	1	073520048



CE

S1P HRO SRC

EN ISO
20345
2011



7352B

scarpe in tessuto mesh ad alta traspirazione con inserti in TPU
Supporto di stabilità tallone, collare "slip on" elasticizzato per facilitare la calzatura
e suola in EVA con battistrada in gomma nitrilica ad alta resistenza

- Puntale in composito
- Lamina antiperforazione in fibra composita
- **LEGGEREZZA STRAORDINARIA:** peso indicativo misura 42: 450 grammi

EU	UK	€		
38	5	105,00	1	073520138
39	6	105,00	1	073520139
40	6,5	105,00	1	073520140
41	7	105,00	1	073520141
42	8	105,00	1	073520142
43	9	105,00	1	073520143
44	10	105,00	1	073520144
45	10,5	105,00	1	073520145
46	11	105,00	1	073520146
47	12	105,00	1	073520147
48	13	105,00	1	073520148



CE

S1P HRO SRC

EN ISO
20345
2011



7353Y

scarpe in tessuto mesh ad alta traspirazione con inserti in TPU
Tomaia dotata di speciali maglie riflettenti ad alta visibilità
Supporto di stabilità tallone, collare "slip on" elasticizzato per facilitare la calzatura
e suola in EVA con battistrada in gomma nitrilica ad alta resistenza

- Puntale in fibra di carbonio
- Lamina antiperforazione in fibra composita
- **LEGGEREZZA STRAORDINARIA:** peso indicativo misura 42: 420 grammi

EU	UK	€		
38	5	136,00	1	073530038
39	6	136,00	1	073530039
40	6,5	136,00	1	073530040
41	7	136,00	1	073530041
42	8	136,00	1	073530042
43	9	136,00	1	073530043
44	10	136,00	1	073530044
45	10,5	136,00	1	073530045
46	11	136,00	1	073530046
47	12	136,00	1	073530047
48	13	136,00	1	073530048



CE

S1P HRO SRC

EN ISO
20345
2011



7354N

scarpe in tessuto mesh idrorepellente con inserti in TPU
 Supporto di stabilità tallone, collare "slip on" elasticizzato per facilitare la calzata
 e suola in EVA con battistrada in gomma nitrilica ad alta resistenza

- Puntale in composito
- Lamina antiperforazione in fibra composita
- **LEGGEREZZA STRAORDINARIA:** peso indicativo misura 42: **460 grammi**

EU	UK	€		
38	5	109,00	1	073540038
39	6	109,00	1	073540039
40	6,5	109,00	1	073540040
41	7	109,00	1	073540041
42	8	109,00	1	073540042
43	9	109,00	1	073540043
44	10	109,00	1	073540044
45	10,5	109,00	1	073540045
46	11	109,00	1	073540046
47	12	109,00	1	073540047
48	13	109,00	1	073540048



EN ISO 20345 2011



CE

S3 HRO SRC

7355V

scarpe alte in tessuto mesh idrorepellente con inserti in TPU
 Supporto di stabilità tallone, collare "slip on" elasticizzato per facilitare la calzata
 e suola in EVA con battistrada in gomma nitrilica ad alta resistenza

- Puntale in composito
- Lamina antiperforazione in fibra composita
- **LEGGEREZZA STRAORDINARIA:** peso indicativo misura 42: **465 grammi**

EU	UK	€		
38	5	116,00	1	073550038
39	6	116,00	1	073550039
40	6,5	116,00	1	073550040
41	7	116,00	1	073550041
42	8	116,00	1	073550042
43	9	116,00	1	073550043
44	10	116,00	1	073550044
45	10,5	116,00	1	073550045
46	11	116,00	1	073550046
47	12	116,00	1	073550047
48	13	116,00	1	073550048



EN ISO 20345 2011



CE

S3 HRO SRC

7362B

scarpe "occupational" in tessuto mesh ad alta traspirazione con inserti in TPU
 Supporto di stabilità tallone, collare "slip on" elasticizzato per facilitare la calzata
 e suola in EVA con battistrada in gomma nitrilica ad alta resistenza

- Senza puntale
- Senza lamina antiperforazione
- **LEGGEREZZA STRAORDINARIA:** peso indicativo misura 42: **330 grammi**

EU	UK	€		
39	6	96,00	1	073620039
40	6,5	96,00	1	073620040
41	7	96,00	1	073620041
42	8	96,00	1	073620042
43	9	96,00	1	073620043
44	10	96,00	1	073620044
45	10,5	96,00	1	073620045
46	11	96,00	1	073620046
47	12	96,00	1	073620047
48	13	96,00	1	073620048



EN ISO 20347 2012



CE

01 FO HRO SRC

7363N

scarpe "occupational" in tessuto mesh idrorepellente con inserti in TPU
 Supporto di stabilità tallone, collare "slip on" elasticizzato per facilitare la calzata
 e suola in EVA con battistrada in gomma nitrilica ad alta resistenza

- Senza puntale
- Senza lamina antiperforazione
- **LEGGEREZZA STRAORDINARIA:** peso indicativo misura 42: **330 grammi**

EU	UK	€		
39	6	100,00	1	073630039
40	6,5	100,00	1	073630040
41	7	100,00	1	073630041
42	8	100,00	1	073630042
43	9	100,00	1	073630043
44	10	100,00	1	073630044
45	10,5	100,00	1	073630045
46	11	100,00	1	073630046
47	12	100,00	1	073630047
48	13	100,00	1	073630048



EN ISO 20347 2012



CE

02 FO HRO SRC

SNEAKERS PRO



7340B

scarpe in tessuto mesh ad alta traspirazione con inserti in PU Alta Frequenza e rinforzo protettivo del puntale in crosta scamosciata. Estremamente leggere - peso indicativo misura 42: **470 g**

- Puntale in alluminio
- Lamina antiperforazione in fibra composita
- Sistema di chiusura FixLock, semplifica la calzata e lo sfilamento della scarpa (in dotazione anche stringhe tradizionali)

**EN ISO
20345
2011**



EU	UK	€	Art.	Art.
36	3,5	134,00	1	073400236
37	4,5	134,00	1	073400237
38	5	134,00	1	073400238
39	6	134,00	1	073400239
40	6,5	134,00	1	073400240
41	7	134,00	1	073400241
42	8	134,00	1	073400242
43	9	134,00	1	073400243
44	10	134,00	1	073400244
45	10,5	134,00	1	073400245
46	11	134,00	1	073400246
47	12	134,00	1	073400247



FIT PRO NET

CE

S1P SRC

7340R

scarpe in tessuto mesh ad alta traspirazione con inserti in PU Alta Frequenza e rinforzo protettivo del puntale in crosta scamosciata. Estremamente leggere - peso indicativo misura 42: **470 g**

- Puntale in alluminio
- Lamina antiperforazione in fibra composita
- Sistema di chiusura FixLock, semplifica la calzata e lo sfilamento della scarpa (in dotazione anche stringhe tradizionali)

**EN ISO
20345
2011**



EU	UK	€	Art.	Art.
36	3,5	134,00	1	073400436
37	4,5	134,00	1	073400437
38	5	134,00	1	073400438
39	6	134,00	1	073400439
40	6,5	134,00	1	073400440
41	7	134,00	1	073400441
42	8	134,00	1	073400442
43	9	134,00	1	073400443
44	10	134,00	1	073400444
45	10,5	134,00	1	073400445
46	11	134,00	1	073400446
47	12	134,00	1	073400447



FIT PRO NET

CE

S1P SRC

7341N

scarpe in micro pelle scamosciata idrorepellente con inserti in PU Alta Frequenza e rinforzo protettivo del puntale in crosta scamosciata. Estremamente leggere - peso indicativo misura 42: **470 g**

- Puntale in alluminio
- Lamina antiperforazione in fibra composita
- Sistema di chiusura FixLock, semplifica la calzata e lo sfilamento della scarpa (in dotazione anche stringhe tradizionali)

**EN ISO
20345
2011**



EU	UK	€	Art.	Art.
36	3,5	141,00	1	073410236
37	4,5	141,00	1	073410237
38	5	141,00	1	073410238
39	6	141,00	1	073410239
40	6,5	141,00	1	073410240
41	7	141,00	1	073410241
42	8	141,00	1	073410242
43	9	141,00	1	073410243
44	10	141,00	1	073410244
45	10,5	141,00	1	073410245
46	11	141,00	1	073410246
47	12	141,00	1	073410247



FIT PRO

CE

S3 SRC

7349RP

scarpe in crosta nabukata idrorepellente
con suola in gomma e anello in morbido PU

- Puntale in composito
- Lamina antiperforazione in fibra composita

EU	UK	€		
38	5	142,00	1	073490138
39	6	142,00	1	073490139
40	6,5	142,00	1	073490140
41	7	142,00	1	073490141
42	8	142,00	1	073490142
43	9	142,00	1	073490143
44	10	142,00	1	073490144
45	10,5	142,00	1	073490145
46	11	142,00	1	073490146
47	12	142,00	1	073490147



CE

S3 HRO SRC

EN ISO
20345
2011



7350RP

scarpe alte in crosta nabukata idrorepellente
con suola in gomma e anello in morbido PU

- Puntale in composito
- Lamina antiperforazione in fibra composita

EU	UK	€		
38	5	145,00	1	073500138
39	6	145,00	1	073500139
40	6,5	145,00	1	073500140
41	7	145,00	1	073500141
42	8	145,00	1	073500142
43	9	145,00	1	073500143
44	10	145,00	1	073500144
45	10,5	145,00	1	073500145
46	11	145,00	1	073500146
47	12	145,00	1	073500147



CE

S3 HRO SRC

EN ISO
20345
2011



MANAGER



7300MK

scarpe in pelle pieno fiore idrorepellente

- Puntale in composito
- Lamina antiperforazione in fibra composita

EU	UK	€		
36	3,5	120,00	1	073000636
37	4,5	120,00	1	073000637
38	5	120,00	1	073000638
39	6	120,00	1	073000639
40	6,5	120,00	1	073000640
41	7	120,00	1	073000641
42	8	120,00	1	073000642
43	9	120,00	1	073000643
44	10	120,00	1	073000644
45	10,5	120,00	1	073000645
46	11	120,00	1	073000646
47	12	120,00	1	073000647
48	13	120,00	1	073000648



CE

S3 SRC

EN ISO
20345
2011



7300FT

scarpe "free time" in pelle pieno fiore idrorepellente, senza puntale e lamina antiperforazione

- Senza puntale
- Senza lamina antiperforazione

EU	UK	€		
36	3,5	99,50	1	073000736
37	4,5	99,50	1	073000737
38	5	99,50	1	073000738
39	6	99,50	1	073000739
40	6,5	99,50	1	073000740
41	7	99,50	1	073000741
42	8	99,50	1	073000742
43	9	99,50	1	073000743
44	10	99,50	1	073000744
45	10,5	99,50	1	073000745
46	11	99,50	1	073000746
47	12	99,50	1	073000747
48	13	99,50	1	073000748

Formula



CE

O2 FO SRC

EN ISO 20347 2012



7319ESD

scarpe in pelle scamosciata traforata, ESD

- Puntale in composito
- Lamina antiperforazione in fibra composita

EU	UK	€		
36	3,5	118,00	1	073190236
37	4,5	118,00	1	073190237
38	5	118,00	1	073190238
39	6	118,00	1	073190239
40	6,5	118,00	1	073190240
41	7	118,00	1	073190241
42	8	118,00	1	073190242
43	9	118,00	1	073190243
44	10	118,00	1	073190244
45	10,5	118,00	1	073190245
46	11	118,00	1	073190246
47	12	118,00	1	073190247
48	13	118,00	1	073190248

Mistral



CE

S1P SRC ESD

EN ISO 20345 2011



HEAVY DUTY

7293HM

scarpe in pelle pieno fiore ingrassata idrorepellente con battistrada in gomma VIBRAM® ad alte prestazioni, inserto antiabrasione sul tallone e copripuntale di rinforzo in poliuretano

- Puntale in fibra di vetro
- Lamina antiperforazione in fibra composita

EU	UK	€		
39	6	148,00	1	072930639
40	6,5	148,00	1	072930640
41	7	148,00	1	072930641
42	8	148,00	1	072930642
43	9	148,00	1	072930643
44	10	148,00	1	072930644
45	10,5	148,00	1	072930645
46	11	148,00	1	072930646
47	12	148,00	1	072930647
48	13	148,00	1	072930648

Heritage



CE

S3 HRO HI SRC

EN ISO 20345 2011



7293HN

scarpe alte in pelle nabuk idrorepellente con SUPPORT SYSTEM per il contenimento laterale della caviglia e rapido sfilamento Battistrada in gomma ad alta resistenza e spunterbo in PU Ampia calzata

- Puntale in acciaio
- Lamina antiperforazione in fibra composita

E	U	€		
39	6	117,00	1	072930839
40	6,5	117,00	1	072930840
41	7	117,00	1	072930841
42	8	117,00	1	072930842
43	9	117,00	1	072930843
44	10	117,00	1	072930844
45	10,5	117,00	1	072930845
46	11	117,00	1	072930846
47	12	117,00	1	072930847

CE



S3 HRO HI SRC



EN ISO 20345 2011



7294HM

scarpe alte in pelle pieno fiore ingrassata idrorepellente con battistrada in gomma VIBRAM® ad alte prestazioni, inserto antiabrasione sul tallone e copripuntale di rinforzo in poliuretano

- Puntale in fibra di vetro
- Lamina antiperforazione in fibra composita

EU	UK	€		
39	6	157,00	1	072940639
40	6,5	157,00	1	072940640
41	7	157,00	1	072940641
42	8	157,00	1	072940642
43	9	157,00	1	072940643
44	10	157,00	1	072940644
45	10,5	157,00	1	072940645
46	11	157,00	1	072940646
47	12	157,00	1	072940647
48	13	157,00	1	072940648

CE



S3 HRO HI SRC



EN ISO 20345 2011



7294HMC

scarpe alte in pelle pieno fiore ingrassata idrorepellente con battistrada in gomma VIBRAM® ad alte prestazioni, inserto antiabrasione sul tallone e copripuntale di rinforzo in poliuretano. Dotate di membrana Tepor, waterproof, antivento ed estremamente traspirante

- Puntale in fibra di vetro
- Lamina antiperforazione in fibra composita

EU	UK	€		
39	6	175,00	1	072940739
40	6,5	175,00	1	072940740
41	7	175,00	1	072940741
42	8	175,00	1	072940742
43	9	175,00	1	072940743
44	10	175,00	1	072940744
45	10,5	175,00	1	072940745
46	11	175,00	1	072940746
47	12	175,00	1	072940747
48	13	175,00	1	072940748

CE



S3 HRO HI CI WR SRC



EN ISO 20345 2011



7294HN

scarpe alte in pelle nabuk idrorepellente con SUPPORT SYSTEM per il contenimento laterale della caviglia e rapido sfilamento Battistrada in gomma ad alta resistenza e spunterbo in PU Ampia calzata

- Puntale in acciaio
- Lamina antiperforazione in fibra composita

EU	UK	€		
39	6	121,00	1	072940839
40	6,5	121,00	1	072940840
41	7	121,00	1	072940841
42	8	121,00	1	072940842
43	9	121,00	1	072940843
44	10	121,00	1	072940844
45	10,5	121,00	1	072940845
46	11	121,00	1	072940846
47	12	121,00	1	072940847

CE



S3 HRO HI RS SRC



EN ISO 20345 2011



ACCESSORIES

7398 O/G

sottopiedi anatomici in schiuma di EVA con cuscinetto ammortizzante nella zona del tallone (ricambio consigliato per la linea di calzature 0-Gravity)



EU	UK	€	👤	📦
38	5	6,00	1	073981238
39	6	6,00	1	073981239
40	6,5	6,00	1	073981240
41	7	6,00	1	073981241
42	8	6,00	1	073981242
43	9	6,00	1	073981243
44	10	6,00	1	073981244
45	10,5	6,00	1	073981245
46	11	6,00	1	073981246
47	12	6,00	1	073981247
48	13	6,00	1	073981248

7398U

sottopiedi anatomici in TPR GEL con elevato effetto ammortizzante, supporto dell'arco plantare e cuscinetto nella zona del tallone



EU	UK	€	👤	📦
36 - 40	3,5 - 6,5	11,00	1	073980058
41 - 46	7 - 11	11,00	1	073980063

7398GEL

sottopiedi anatomici con inserto in gel



EU	UK	€	👤	📦
35	2,5	3,70	1	073980835
36	3,5	3,70	1	073980836
37	4,5	3,70	1	073980837
38	5	3,70	1	073980838
39	6	3,70	1	073980839
40	6,5	3,70	1	073980840
41	7	3,70	1	073980841
42	8	3,70	1	073980842
43	9	3,70	1	073980843
44	10	3,70	1	073980844
45	10,5	3,70	1	073980845
46	11	3,70	1	073980846
47	12	3,70	1	073980847
48	13	3,70	1	073980848

7398EF

sottopiedi anatomici in schiuma di poliuretano con rialzo ammortizzante nella zona del tallone



EU	UK	€	👤	📦
35	2,5	7,00	1	073981135
36	3,5	7,00	1	073981136
37	4,5	7,00	1	073981137
38	5	7,00	1	073981138
39	6	7,00	1	073981139
40	6,5	7,00	1	073981140
41	7	7,00	1	073981141
42	8	7,00	1	073981142
43	9	7,00	1	073981143
44	10	7,00	1	073981144
45	10,5	7,00	1	073981145
46	11	7,00	1	073981146
47	12	7,00	1	073981147
48	13	7,00	1	073981148

7399 A/N...

confezione 10 paia di stringhe



	cm	€	👤	📦
7399A/N 100	100	13,20	1	073990010
7399A/N 120	120	15,50	1	073990012
7399A/N 140	140	19,00	1	073990017

I prezzi indicati sono relativi a 10 paia

7421

calze lunghe in spugna elastocompressiva con rinforzi in nylon e cotone su punta e tallone
Pianta in fibra di bamboo, resistente, antimicotico e traspirante



	EU	€	👤	📦
M	39-42	14,00	1	074210002
L	43-46	14,00	1	074210004

7423

calze corte elastocompressive con rinforzi in nylon e cotone su punta e tallone
Pianta in fibra di bamboo, resistente, antimicotico e traspirante



	EU	€	👤	📦
M	39-42	9,00	1	074230002
L	43-46	9,00	1	074230004

7425

calze corte con inserti in texture traspirante e rinforzi in nylon/cotone su punta e tallone
Pianta in nylon intrecciato con fibra di bamboo, resistente, antimicotico e traspirante



	EU	€	👤	📦
M	39-42	9,20	1	074250002
L	43-46	9,20	1	074250004

7427

calze maxi sneaker con inserti protettivi e traspiranti su zona tibia e collo del piede.
Rinforzi in nylon e cotone su punta e tallone e pianta in fibra di bamboo, resistente, antimicotico e traspirante



	EU	€	👤	📦
M	39-42	7,80	1	074270002
L	43-46	7,80	1	074270004

7429

calze maxi sneaker con inserti in texture traspirante e rinforzi in nylon/cotone su punta e tallone
Pianta in nylon intrecciato con fibra di bamboo, resistente, antimicotico e traspirante



	EU	€	👤	📦
M	39-42	7,20	1	074290002
L	43-46	7,20	1	074290004

7431P

due paia di calzini sneaker con inserti in texture traspirante e rinforzi in nylon/cotone su punta e tallone
Pianta in nylon intrecciato con fibra di bamboo, resistente, antimicotico e traspirante.
Un paio di colore nero/arancio e un paio di colore nero/grigio



	EU	€	👤	📦
M	39-42	6,90	1	074310102
L	43-46	6,90	1	074310104



ABBIGLIAMENTO DA LAVORO

Beta WORK

La linea di abbigliamento da lavoro ha conquistato nel corso degli anni la fiducia e la preferenza dei professionisti più esigenti. Il successo del prodotto ha generato la costante evoluzione e l'ampliamento della gamma di offerta.

I capi di abbigliamento prodotti da Beta Utensili S.p.a. sono conformi alla seguente normativa: **EN ISO 13688:2013**
 Il DPI protegge l'utilizzatore dai rischi fisici di lieve entità come: piccole abrasioni, raggi solari, vento, freddo polveri non nocive ed imbrattamento da materiali non tossici. Tale protezione è riconducibile alla prima categoria del DDL 475 del 04/12/1992.

ISTRUZIONI PER L'UTILIZZO E LA CONSERVAZIONE

Il capo va indossato correttamente in modo che possa proteggere le parti del corpo dell'utilizzatore. Il capo va conservato in un luogo fresco ed asciutto, nel suo imballaggio originale, al riparo da fonti di calore, luce solare, polvere ed agenti atmosferici.

CONFEZIONAMENTO

- ABBIGLIAMENTO DA LAVORO: busta appendibile
- ABBIGLIAMENTO TEMPO LIBERO: busta non appendibile

RESTRINGIMENTO

Tutte le fibre naturali si restringono dopo il lavaggio in acqua. Il restringimento può variare dall'1% al 5% in funzione di diversi parametri, in particolare il tipo di fibra e la temperatura dell'acqua.

	I	F	D	E	UK	USA
XS	46	38	42	40	30	32
S	48	40	44	42	32	34
M	50	42	46	44	34	36
L	52	44	48	46	36	38
XL	54	46	50	48	38	40
2XL	56	48	52	50	40	42
3XL	58	50	54	52	42	44
4XL	60	52	56	54	44	46

EN ISO 13688:2013								
	XS	S	M	L	XL	2XL	3XL	4XL
A	88-92	92-96	96-104	104-108	108-116	116-124	124-132	132-140
B	79-83	83-87	87-91	91-95	95-100	100-107	107-112	112-120
H	158-164	164-170	170-176	176-182	182-188	188-194	194-200	200-206

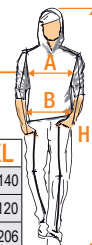

PANTS



7525

jeans da lavoro elasticizzati prelavati in 68% cotone denim, 29% poliestere, 3% tessuto elasticizzato, 100Z

CE



	€		
XS	53,50	1	075250046
S	53,50	1	075250048
M	53,50	1	075250050
L	53,50	1	075250052
XL	53,50	1	075250054
XXL	53,50	1	075250056
XXXL	53,50	1	075250058

7528

jeans da lavoro elasticizzati in 98% cotone e 2% tessuto elasticizzato Slim fit

CE



	€		
XS	49,50	1	075280046
S	49,50	1	075280048
M	49,50	1	075280050
L	49,50	1	075280052
XL	49,50	1	075280054
XXL	49,50	1	075280056
XXXL	49,50	1	075280058

7529

bermuda jeans da lavoro elasticizzati in 98% cotone e 2% tessuto elasticizzato Slim fit

CE



	€		
XS	39,50	1	075290046
S	39,50	1	075290048
M	39,50	1	075290050
L	39,50	1	075290052
XL	39,50	1	075290054
XXL	39,50	1	075290056
XXXL	39,50	1	075290058

Beta

7650

pantaloni da lavoro multitasche elasticizzati 90% Nylon -10% spandex, 260 g, antracite Tasche per ginocchiere, tasche posteriori e fondo gamba rinforzati in poliestere 600D, cavallo antistrappo

CE



	€		
XS	77,00	1	076500000
S	77,00	1	076500001
M	77,00	1	076500002
L	77,00	1	076500003
XL	77,00	1	076500004
XXL	77,00	1	076500005
XXXL	77,00	1	076500006

7810

pantaloni multitasche "work trekking" HEAVY 90% nylon, 10% tessuto elasticizzato, 265 g, antracite Slim fit, vestibilità ergonomica per favorire i movimenti e tessuto bi-estensibile per aumentare il comfort. Inserti rinforzati su ginocchia, cavallo e fondo gamba



	€		
S	70,00	1	078100101
M	70,00	1	078100102
L	70,00	1	078100103
XL	70,00	1	078100104
XXL	70,00	1	078100105

7811

pantaloni "work trekking" MID SEASON
90% nylon, 10% tessuto elasticizzato, 230 g, grigio
Slim fit, vestibilità ergonomica per favorire i
movimenti e tessuto bi-estensibile per aumentare
il comfort. Insetti rinforzati su ginocchia, cavallo e
fondo gamba



	€		
S	67,00	1	078110001
M	67,00	1	078110002
L	67,00	1	078110003
XL	67,00	1	078110004
XXL	67,00	1	078110005

7812

pantaloni "work trekking" LIGHT
95% nylon, 5% tessuto elasticizzato, 140 g,
grigio
slim fit, vestibilità ergonomica per favorire
i movimenti e tessuto bi-estensibile per
aumentare il comfort inserti rinforzati su
ginocchia, cavallo e fondo gamba



	€		
S	64,00	1	078120001
M	64,00	1	078120002
L	64,00	1	078120003
XL	64,00	1	078120004
XXL	64,00	1	078120005

7813

bermuda "work trekking" LIGHT
95% nylon, 5% tessuto elasticizzato, 140 g,
grigio
slim fit, vestibilità ergonomica per favorire
i movimenti e tessuto bi-estensibile per
aumentare il comfort.



	€		
S	50,00	1	078130001
M	50,00	1	078130002
L	50,00	1	078130003
XL	50,00	1	078130004
XXL	50,00	1	078130005

7816BL

pantaloni da lavoro multitasche in T/C Canvas
260 g, blu
Tasche per ginocchiere e fondo gamba
rinforzati in
poliestere 600D, cavallo antistrappo ed inserto
elastico posteriore per facilitare i movimenti

CE



	€		
XS	64,00	1	078160100
S	64,00	1	078160101
M	64,00	1	078160102
L	64,00	1	078160103
XL	64,00	1	078160104
XXL	64,00	1	078160105
XXXL	64,00	1	078160106

7816G

pantaloni da lavoro multitasche in T/C Canvas
260 g, grigio
Tasche per ginocchiere e fondo gamba
rinforzati in poliestere 600D, cavallo
antistrappo ed inserto elastico posteriore per
facilitare i movimenti

CE



	€		
XS	64,00	1	078160000
S	64,00	1	078160001
M	64,00	1	078160002
L	64,00	1	078160003
XL	64,00	1	078160004
XXL	64,00	1	078160005
XXXL	64,00	1	078160006

7817N

pantaloni multitasche "work trekking" HEAVY
90% nylon, 10% tessuto elasticizzato, 265 g,
nero
Slim fit, vestibilità ergonomica per favorire
i movimenti e tessuto bi-estensibile per
aumentare il comfort.
Insetti rinforzati su ginocchia, cavallo e fondo
gamba



	€		
S	70,00	1	078170101
M	70,00	1	078170102
L	70,00	1	078170103
XL	70,00	1	078170104
XXL	70,00	1	078170105



7819B

pantaloni "work trekking" LIGHT
95% nylon, 5% tessuto elasticizzato, 140 g,
blu
slim fit, vestibilità ergonomica per favorire i
movimenti e tessuto
bi-estensibile per aumentare il comfort inserti
rinforzati su ginocchia, cavallo e fondo gamba



	€		
S	64,00	1	078190101
M	64,00	1	078190102
L	64,00	1	078190103
XL	64,00	1	078190104
XXL	64,00	1	078190105

7880SC

pantaloni da lavoro elasticizzati
in T/C Canvas 290 g, nero
Slim fit, cavallo antistrappo e vita elasticizzata
ai lati

CE



	€		
XS	53,00	1	078800000
S	53,00	1	078800001
M	53,00	1	078800002
L	53,00	1	078800003
XL	53,00	1	078800004
XXL	53,00	1	078800005
XXXL	53,00	1	078800006

SHIRT & T-SHIRT**7547BL**

polo 3 bottoni
in 100% cotone 200 g, blu



	€		
XS	23,00	2	075470200
S	23,00	2	075470201
M	23,00	2	075470202
L	23,00	2	075470203
XL	23,00	2	075470204
XXL	23,00	2	075470205
XXXL	23,00	2	075470206

7547G

polo 3 bottoni
in 100% cotone 200 g, grigio



	€		
XS	23,00	2	075470300
S	23,00	2	075470301
M	23,00	2	075470302
L	23,00	2	075470303
XL	23,00	2	075470304
XXL	23,00	2	075470305
XXXL	23,00	2	075470306

**7547N**

polo 3 bottoni
in 100% cotone 200 g, nero



	€		
XS	23,00	2	075470400
S	23,00	2	075470401
M	23,00	2	075470402
L	23,00	2	075470403
XL	23,00	2	075470404
XXL	23,00	2	075470405
XXXL	23,00	2	075470406

7549BL

t-shirt work in 100% cotone 150 g, blu



	€		
XS	15,00	5	075490200
S	15,00	5	075490201
M	15,00	5	075490202
L	15,00	5	075490203
XL	15,00	5	075490204
XXL	15,00	5	075490205
XXXL	15,00	5	075490206

7549G

t-shirt work in 100% cotone 150 g, grigio



	€		
XS	15,00	5	075490300
S	15,00	5	075490301
M	15,00	5	075490302
L	15,00	5	075490303
XL	15,00	5	075490304
XXL	15,00	5	075490305
XXXL	15,00	5	075490306

7549N

t-shirt work in 100% cotone 150 g, nero



	€		
XS	15,00	5	075490400
S	15,00	5	075490401
M	15,00	5	075490402
L	15,00	5	075490403
XL	15,00	5	075490404
XXL	15,00	5	075490405
XXXL	15,00	5	075490406

7634G

felpa tecnica zip lunga 325 g, grigio
67% poliestere, 28% rayon, 5% spandex
Tessuto 3D che imprigiona l'aria garantendo
elevata traspirabilità e libertà di movimento



	€		
XS	69,00	1	076340100
S	69,00	1	076340101
M	69,00	1	076340102
L	69,00	1	076340103
XL	69,00	1	076340104
XXL	69,00	1	076340105
XXXL	69,00	1	076340106

7657N

pile zip lunga elasticizzato 280 g, nero
95% poliestere, 5% spandex



	€		
XS	47,00	1	076570000
S	47,00	1	076570001
M	47,00	1	076570002
L	47,00	1	076570003
XL	47,00	1	076570004
XXL	47,00	1	076570005
XXXL	47,00	1	076570006

FLEECE



7634B

felpa tecnica zip lunga 325 g, blu
67% poliestere, 28% rayon, 5% spandex
Tessuto 3D che imprigiona l'aria garantendo
elevata traspirabilità e libertà di movimento



	€		
XS	69,00	1	076340200
S	69,00	1	076340201
M	69,00	1	076340202
L	69,00	1	076340203
XL	69,00	1	076340204
XXL	69,00	1	076340205
XXXL	69,00	1	076340206

7635N

micropile zip corta 180 g
nero



	€		
XS	28,00	1	076350500
S	28,00	1	076350501
M	28,00	1	076350502
L	28,00	1	076350503
XL	28,00	1	076350504
XXL	28,00	1	076350505
XXXL	28,00	1	076350506

7654N

micropile zip corta elasticizzato 180 g, nero
95% poliestere, 5% spandex



	€		
XS	37,00	1	076540000
S	37,00	1	076540001
M	37,00	1	076540002
L	37,00	1	076540003
XL	37,00	1	076540004
XXL	37,00	1	076540005
XXXL	37,00	1	076540006

7575N

gilet softshell
in 90% nylon, 10% tessuto elasticizzato, 250 g



	€		
S	70,00	1	075750301
M	70,00	1	075750302
L	70,00	1	075750303
XL	70,00	1	075750304
XXL	70,00	1	075750305
XXXL	70,00	1	075750306

Beta

JACKETS



7577N

gilet in 100% poliestere microfibra 50D
imbottito e foderato, nero
Insero elastico sul giromanica



GRUPPO	€	ST	ART
XS	48,50	1	075770000
S	48,50	1	075770001
M	48,50	1	075770002
L	48,50	1	075770003
XL	48,50	1	075770004
XXL	48,50	1	075770005
XXXL	48,50	1	075770006

7579T

gilet da lavoro multitasche in nylon
impermeabilizzato 300D
con inserti elasticizzati per favorire i
movimenti, nero
Imbottitura in poliestere 140 g



GRUPPO	€	ST	ART
S	55,00	1	075790001
M	55,00	1	075790002
L	55,00	1	075790003
XL	55,00	1	075790004
XXL	55,00	1	075790005
XXXL	55,00	1	075790006

7658N

giacca softshell 94% poliestere, 6% spandex,
290 g, antracite
Dotato di membrana TPU impermeabile,
antivento e traspirante (resistenza a colonne
d'acqua 8.000 mm - traspirabilità 8.000 mvp)



GRUPPO	€	ST	ART
S	84,00	1	076580001
M	84,00	1	076580002
L	84,00	1	076580003
XL	84,00	1	076580004
XXL	84,00	1	076580005
XXXL	84,00	1	076580006

7659N

giacca softshell 94% poliestere, 6% spandex, 290 g
con cappuccio e maniche staccabili, nero
Dotato di membrana TPU impermeabile, antivento
e traspirante
(resistenza a colonne d'acqua 8.000 mm -
traspirabilità 8.000 mvp)



GRUPPO	€	ST	ART
S	120,00	1	076590001
M	120,00	1	076590002
L	120,00	1	076590003
XL	120,00	1	076590004
XXL	120,00	1	076590005
XXXL	120,00	1	076590006

7734

giaccone triplo uso in poliestere Oxford 300D
impermeabilizzato, con spalmatura in PU,
grigio
Dotato di cappuccio a scomparsa
e giacca interna staccabile in 100% poliestere,
nera



GRUPPO	€	ST	ART
S	171,00	1	077340001
M	171,00	1	077340002
L	171,00	1	077340003
XL	171,00	1	077340004
XXL	171,00	1	077340005
XXXL	171,00	1	077340006

7780T

bomber da lavoro multitasche in nylon
impermeabilizzato 300D
con inserti elasticizzati per favorire i
movimenti, nero
Imbottitura in poliestere 160 g e cappuccio
staccabile



GRUPPO	€	ST	ART
S	91,00	1	077800101
M	91,00	1	077800102
L	91,00	1	077800103
XL	91,00	1	077800104
XXL	91,00	1	077800105
XXXL	91,00	1	077800106

BASIC

7840BL

pantaloni da lavoro in T/C twill 245 g, blu
Vita elasticizzata ai lati



Beta EASY



GRUPPO	€	ST	ART
XS	33,50	1	078400100
S	33,50	1	078400101
M	33,50	1	078400102
L	33,50	1	078400103
XL	33,50	1	078400104
XXL	33,50	1	078400105
XXXL	33,50	1	078400106
XXXXL	33,50	1	078400107

7849BL

giacca da lavoro in T/C twill 245 g, blu
Fascia in vita elasticizzata

CE

BetaEASY



	€		
XS	36,50	1	078490100
S	36,50	1	078490101
M	36,50	1	078490102
L	36,50	1	078490103
XL	36,50	1	078490104
XXL	36,50	1	078490105
XXXL	36,50	1	078490106
XXXXL	36,50	1	078490107

EASY LIGHT

7860G

Pantaloni leggeri da lavoro
in T/C twill 180 g con inserti in Oxford, grigio
Nuovo Design - Migliore vestibilità

CE

BetaEASY

LIGHT



	€		
XS	43,50	1	078600800
S	43,50	1	078600801
M	43,50	1	078600802
L	43,50	1	078600803
XL	43,50	1	078600804
XXL	43,50	1	078600805
XXXL	43,50	1	078600806
XXXXL	43,50	1	078600807

7861G

Bermuda leggeri da lavoro
in T/C twill 180 g con inserti in Oxford, grigio
Nuovo Design - Migliore vestibilità

CE

BetaEASY

LIGHT



	€		
XS	36,50	1	078610800
S	36,50	1	078610801
M	36,50	1	078610802
L	36,50	1	078610803
XL	36,50	1	078610804
XXL	36,50	1	078610805
XXXL	36,50	1	078610806
XXXXL	36,50	1	078610807

7863G

Salopette leggera da lavoro
in T/C twill 180 g con inserti in Oxford, grigio
Nuovo Design - Migliore vestibilità

CE

BetaEASY

LIGHT



	€		
XS	53,00	1	078630800
S	53,00	1	078630801
M	53,00	1	078630802
L	53,00	1	078630803
XL	53,00	1	078630804
XXL	53,00	1	078630805
XXXL	53,00	1	078630806
XXXXL	53,00	1	078630807



7865G

Tuta leggera da lavoro
in T/C twill 180 g con inserti in Oxford, grigio
Nuovo Design - Migliore vestibilità

CE

BetaEASY

LIGHT



	€		
XS	69,00	1	078650800
S	69,00	1	078650801
M	69,00	1	078650802
L	69,00	1	078650803
XL	69,00	1	078650804
XXL	69,00	1	078650805
XXXL	69,00	1	078650806
XXXXL	69,00	1	078650807

7867G

Gilet leggero da lavoro
in T/C twill 180 g con inserti in Oxford, grigio
Nuovo Design - Migliore vestibilità

CE

BetaEASY

LIGHT



	€		
XS	40,50	1	078670800
S	40,50	1	078670801
M	40,50	1	078670802
L	40,50	1	078670803
XL	40,50	1	078670804
XXL	40,50	1	078670805
XXXL	40,50	1	078670806
XXXXL	40,50	1	078670807



7869G

Giacca leggera da lavoro
in T/C twill 180 g con inserti in Oxford, grigio
Nuovo Design - Migliore vestibilità

CE

Beta EASY

LIGHT



	€	
XS	47,50	1 078690800
S	47,50	1 078690801
M	47,50	1 078690802
L	47,50	1 078690803
XL	47,50	1 078690804
XXL	47,50	1 078690805
XXXL	47,50	1 078690806
XXXXL	47,50	1 078690807



7900G

Pantaloni da lavoro
in T/C canvas 260 g con inserti in Oxford, grigio
Nuovo Design - Migliore vestibilità

CE

Beta EASY



	€	
XS	48,00	1 079000800
S	48,00	1 079000801
M	48,00	1 079000802
L	48,00	1 079000803
XL	48,00	1 079000804
XXL	48,00	1 079000805
XXXL	48,00	1 079000806
XXXXL	48,00	1 079000807

7900P

Pantaloni da lavoro
in T/C canvas 260 g con inserti in Oxford, petrol
Nuovo Design - Migliore vestibilità

CE

Beta EASY



	€	
XS	48,00	1 079000600
S	48,00	1 079000601
M	48,00	1 079000602
L	48,00	1 079000603
XL	48,00	1 079000604
XXL	48,00	1 079000605
XXXL	48,00	1 079000606
XXXXL	48,00	1 079000607

7900B

Pantaloni da lavoro
in T/C canvas 260 g con inserti in Oxford, blu
Nuovo Design - Migliore vestibilità

CE

Beta EASY



	€	
XS	48,00	1 079000700
S	48,00	1 079000701
M	48,00	1 079000702
L	48,00	1 079000703
XL	48,00	1 079000704
XXL	48,00	1 079000705
XXXL	48,00	1 079000706
XXXXL	48,00	1 079000707

7901G

Bermuda da lavoro
in T/C canvas 260 g con inserti in Oxford, grigio
Nuovo Design - Migliore vestibilità

CE

Beta EASY



	€	
XS	39,00	1 079010800
S	39,00	1 079010801
M	39,00	1 079010802
L	39,00	1 079010803
XL	39,00	1 079010804
XXL	39,00	1 079010805
XXXL	39,00	1 079010806
XXXXL	39,00	1 079010807

7900V

Pantaloni da lavoro
in T/C canvas 260 g con inserti in Oxford, verde
Nuovo Design - Migliore vestibilità

CE

Beta EASY



	€	
XS	48,00	1 079000500
S	48,00	1 079000501
M	48,00	1 079000502
L	48,00	1 079000503
XL	48,00	1 079000504
XXL	48,00	1 079000505
XXXL	48,00	1 079000506
XXXXL	48,00	1 079000507



7903G

Salopette da lavoro
in T/C canvas 260 g con inserti in Oxford,
grigio
Nuovo Design - Migliore vestibilità

CE

Beta EASY



	€		
XS	60,00	1	079030800
S	60,00	1	079030801
M	60,00	1	079030802
L	60,00	1	079030803
XL	60,00	1	079030804
XXL	60,00	1	079030805
XXXL	60,00	1	079030806
XXXXL	60,00	1	079030807

7903P

Salopette da lavoro
in T/C canvas 260 g con inserti in Oxford,
petrol

CE

Beta EASY



	€		
XS	60,00	1	079030600
S	60,00	1	079030601
M	60,00	1	079030602
L	60,00	1	079030603
XL	60,00	1	079030604
XXL	60,00	1	079030605
XXXL	60,00	1	079030606
XXXXL	60,00	1	079030607

7905G

Tuta da lavoro
in T/C canvas 260 g con inserti in Oxford,
grigio
Nuovo Design - Migliore vestibilità

CE

Beta EASY



	€		
XS	75,00	1	079050800
S	75,00	1	079050801
M	75,00	1	079050802
L	75,00	1	079050803
XL	75,00	1	079050804
XXL	75,00	1	079050805
XXXL	75,00	1	079050806
XXXXL	75,00	1	079050807

7904N

bomber da lavoro imbottito
in T/C canvas 270 g, inserti in "Oxford", nero
Imbottitura in poliestere 140 g

Beta EASY



	€		
XS	89,00	1	079040800
S	89,00	1	079040801
M	89,00	1	079040802
L	89,00	1	079040803
XL	89,00	1	079040804
XXL	89,00	1	079040805
XXXL	89,00	1	079040806
XXXXL	89,00	1	079040807



7907G

Gilet da lavoro
in T/C canvas 260 g con inserti in Oxford,
grigio
Nuovo Design - Migliore vestibilità

CE

Beta EASY



	€		
XS	44,50	1	079070800
S	44,50	1	079070801
M	44,50	1	079070802
L	44,50	1	079070803
XL	44,50	1	079070804
XXL	44,50	1	079070805
XXXL	44,50	1	079070806
XXXXL	44,50	1	079070807

7907P

Gilet da lavoro
in T/C canvas 260 g con inserti in Oxford,
petrol

CE

Beta EASY



	€		
XS	44,50	1	079070600
S	44,50	1	079070601
M	44,50	1	079070602
L	44,50	1	079070603
XL	44,50	1	079070604
XXL	44,50	1	079070605
XXXL	44,50	1	079070606
XXXXL	44,50	1	079070607

7909G

Giacca da lavoro
in T/C canvas 260 g con inserti in Oxford,
grigio
Nuovo Design - Migliore vestibilità

CE

Beta EASY



	€		
XS	53,00	1	079090800
S	53,00	1	079090801
M	53,00	1	079090802
L	53,00	1	079090803
XL	53,00	1	079090804
XXL	53,00	1	079090805
XXXL	53,00	1	079090806
XXXXL	53,00	1	079090807

7909V

Giacca da lavoro
in T/C canvas 260 g con inserti in Oxford,
verde

CE

Beta EASY



	€		
XS	53,00	1	079090500
S	53,00	1	079090501
M	53,00	1	079090502
L	53,00	1	079090503
XL	53,00	1	079090504
XXL	53,00	1	079090505
XXXL	53,00	1	079090506
XXXXL	53,00	1	079090507

7909P

Giacca da lavoro
in T/C canvas 260 g con inserti in Oxford,
petrol

CE

Beta EASY



	€		
XS	53,00	1	079090600
S	53,00	1	079090601
M	53,00	1	079090602
L	53,00	1	079090603
XL	53,00	1	079090604
XXL	53,00	1	079090605
XXXL	53,00	1	079090606
XXXXL	53,00	1	079090607

7909B

Giacca da lavoro
in T/C canvas 260 g con inserti in Oxford, blu

CE

Beta EASY



	€		
XS	53,00	1	079090700
S	53,00	1	079090701
M	53,00	1	079090702
L	53,00	1	079090703
XL	53,00	1	079090704
XXL	53,00	1	079090705
XXXL	53,00	1	079090706
XXXXL	53,00	1	079090707

STRETCH

7830ST

pantaloni da lavoro elasticizzati
in T/C Twill 250 g, grigio
Slim fit, cavallo antistrappo e vita elasticizzata
ai lati

CE



	€		
XS	52,00	1	078300000
S	52,00	1	078300001
M	52,00	1	078300002
L	52,00	1	078300003
XL	52,00	1	078300004
XXL	52,00	1	078300005
XXXL	52,00	1	078300006

Beta

7831ST

bermuda da lavoro elasticizzati
in T/C Twill 250 g, grigio
Slim fit, cavallo antistrappo e vita elasticizzata
ai lati

CE



	€		
XS	40,00	1	078310000
S	40,00	1	078310001
M	40,00	1	078310002
L	40,00	1	078310003
XL	40,00	1	078310004
XXL	40,00	1	078310005
XXXL	40,00	1	078310006

7833ST

salopette da lavoro elasticizzata
in T/C Twill 250 g, grigio
Slim fit, cavallo antistrappo e vita elasticizzata

CE



	€		
XS	62,00	1	078330000
S	62,00	1	078330001
M	62,00	1	078330002
L	62,00	1	078330003
XL	62,00	1	078330004
XXL	62,00	1	078330005
XXXL	62,00	1	078330006

Beta

7835ST

tuta da lavoro elasticizzata
in T/C Twill 250 g, grigio
Slim fit, cavallo antistrappo e vita elasticizzata

CE



	€		
XS	83,00	1	078350000
S	83,00	1	078350001
M	83,00	1	078350002
L	83,00	1	078350003
XL	83,00	1	078350004
XXL	83,00	1	078350005
XXXL	83,00	1	078350006

TOP LINE

7820

pantaloni da lavoro in T/C canvas ritorto 280 g,
inserti in Cordura® e Reflex 3M Scotchlite™,
nero/grigio

CE



CORDURA
FABRIC
3M Scotchlite
Reflective Material

	€		
XS	83,50	1	078200000
S	83,50	1	078200001
M	83,50	1	078200002
L	83,50	1	078200003
XL	83,50	1	078200004
XXL	83,50	1	078200005
XXXL	83,50	1	078200006
XXXXL	83,50	1	078200007

7821

bermuda da lavoro in T/C canvas ritorto 280 g,
nero/grigio

CE



	€		
XS	62,00	1	078210000
S	62,00	1	078210001
M	62,00	1	078210002
L	62,00	1	078210003
XL	62,00	1	078210004
XXL	62,00	1	078210005
XXXL	62,00	1	078210006
XXXXL	62,00	1	078210007

7823

salopette da lavoro in T/C canvas ritorto 280 g,
inserti in Cordura® e Reflex 3M Scotchlite™,
nero/grigio

CE



CORDURA
FABRIC
3M Scotchlite
Reflective Material

	€		
XS	100,00	1	078230000
S	100,00	1	078230001
M	100,00	1	078230002
L	100,00	1	078230003
XL	100,00	1	078230004
XXL	100,00	1	078230005
XXXL	100,00	1	078230006
XXXXL	100,00	1	078230007

7825

tuta da lavoro in T/C canvas ritorto 280 g,
inserti in Cordura® e Reflex 3M Scotchlite™,
nero/grigio

CE



CORDURA
FABRIC
3M Scotchlite
Reflective Material

	€		
XS	133,00	1	078250000
S	133,00	1	078250001
M	133,00	1	078250002
L	133,00	1	078250003
XL	133,00	1	078250004
XXL	133,00	1	078250005
XXXL	133,00	1	078250006
XXXXL	133,00	1	078250007

Beta

7829

giacca da lavoro in T/C canvas ritorto 280 g,
inserti in Cordura® e Reflex 3M Scotchlite™,
nero/grigio

CE



3M Scotchlite®
Reflective Material
CORDURA®
FABRIC

Dimensione	€	Art.	Art.
XS	92,00	1	078290000
S	92,00	1	078290001
M	92,00	1	078290002
L	92,00	1	078290003
XL	92,00	1	078290004
XXL	92,00	1	078290005
XXXL	92,00	1	078290006
XXXXL	92,00	1	078290007

7931G

bermuda da lavoro
in 100% cotone elasticizzato, 220 g
Slim Fit

CE



Dimensione	€	Art.	Art.
XS	40,00	1	079310300
S	40,00	1	079310301
M	40,00	1	079310302
L	40,00	1	079310303
XL	40,00	1	079310304
XXL	40,00	1	079310305
XXXL	40,00	1	079310306

7933G

salopette da lavoro
in 100% cotone elasticizzato, 220 g
Slim Fit

CE



Dimensione	€	Art.	Art.
XS	65,00	1	079330300
S	65,00	1	079330301
M	65,00	1	079330302
L	65,00	1	079330303
XL	65,00	1	079330304
XXL	65,00	1	079330305
XXXL	65,00	1	079330306

7930G

pantaloni da lavoro
in 100% cotone elasticizzato, 220 g
Slim Fit

CE



Dimensione	€	Art.	Art.
XS	52,00	1	079300300
S	52,00	1	079300301
M	52,00	1	079300302
L	52,00	1	079300303
XL	52,00	1	079300304
XXL	52,00	1	079300305
XXXL	52,00	1	079300306



7935G

tuta da lavoro
in 100% cotone elasticizzato, 220 g
Slim Fit

CE



Dimensione	€	Art.	Art.
XS	87,00	1	079350300
S	87,00	1	079350301
M	87,00	1	079350302
L	87,00	1	079350303
XL	87,00	1	079350304
XXL	87,00	1	079350305
XXXL	87,00	1	079350306

7939G

giacca da lavoro
in 100% cotone elasticizzato, 220 g
Slim Fit

CE



Dimensione	€	Art.	Art.
XS	56,00	1	079390300
S	56,00	1	079390301
M	56,00	1	079390302
L	56,00	1	079390303
XL	56,00	1	079390304
XXL	56,00	1	079390305
XXXL	56,00	1	079390306

RAIN

7970

pantaloni impermeabili in PVC Tricot, blu

CE



EN 343

	€		
XS	36,00	1	079700000
S	36,00	1	079700001
M	36,00	1	079700002
L	36,00	1	079700003
XL	36,00	1	079700004
XXL	36,00	1	079700005
XXXL	36,00	1	079700006

7971L

pantaloni impermeabili in poliestere spalmato PVC

con cuciture termonastrate, blu
Dotato di elastico in vita e fondo gamba regolabile con bottoni automatici

CE



EN 343

	€		
XS	20,00	1	079710100
S	20,00	1	079710101
M	20,00	1	079710102
L	20,00	1	079710103
XL	20,00	1	079710104
XXL	20,00	1	079710105
XXXL	20,00	1	079710106

7978L

cappotto impermeabile in poliestere spalmato PVC con cappuccio fisso e cuciture termonastrate, blu
dotato di bottoni automatici che permettono di accorciarlo a 3/4

CE



EN 343

	€		
XS	28,00	1	079780100
S	28,00	1	079780101
M	28,00	1	079780102
L	28,00	1	079780103
XL	28,00	1	079780104
XXL	28,00	1	079780105
XXXL	28,00	1	079780106

7979

giacca impermeabile in PVC Tricot, blu

CE



	€		
S	58,50	1	079790001
M	58,50	1	079790002
L	58,50	1	079790003
XL	58,50	1	079790004
XXL	58,50	1	079790005
XXXL	58,50	1	079790006

Beta

UNDERWEAR

7991N

calzamaglia intima tecnica in 100% poliestere 130 g, nero



	€		
S	17,00	1	079910001
M	17,00	1	079910002
L	17,00	1	079910003
XL	17,00	1	079910004
XXL	17,00	1	079910005

7992N

maglia intima tecnica maniche lunghe in 100% poliestere 130 g, nero



	€		
S	21,50	1	079920001
M	21,50	1	079920002
L	21,50	1	079920003
XL	21,50	1	079920004
XXL	21,50	1	079920005

ACCESSORIES

7800G

coppia ginocchieri da lavoro



7800G € 11,50 1 078000500

7980N

cappellino anti pioggia
100% poliestere spalmato PU
con trattamento water repellent



L = Ø 58 cm € 9,90 1 079800058
XL = Ø 60 cm € 9,90 1 079800060

7980R

berretto invernale con risvolto in 100% acrilico
Imbottitura in 3M Thinsulate™, nero



7980R € 8,90 10 079800111

7984G

cintura da lavoro in 100% TPE e fibbia in
metallo zinco cromato
taglia unica 125 cm accorciabile, larghezza
35 mm,
nero



7984G € 14,00 1 079840525

7985

scaldacollo in micropile con regolatore, nero
utilizzabile anche come cappello

CE



7985 € 10,50 10 079850111

7104 90

colonnine in plastica con base riempibile



7104 90 H mm € 14,50 4 071040004

7105 6

catena plastica di delimitazione



7105 6 Ø mm L m € 50,00 1 071050006

7109A

cartelli di avvertenza in alluminio



7109A1 H mm € 8,80 1 071090001
7109A2 140 € 8,80 1 071090002
7109A3 140 € 8,80 1 071090003
7109A4 140 € 8,80 1 071090004

7109D

cartelli di divieto



7109D1 H mm € 8,80 1 071090051
7109D2 115 € 8,80 1 071090052
7109D3 115 € 8,80 1 071090053

7195A

mascherine antipolvere FFP1

CE



7195A € 4,90 10 071950004

7051MP

maschera di protezione
con visiera in policarbonato

CE



EN166

7051MP € 7,10 5 070510001

7061TC

occhiali di protezione con lenti in policarbonato
trasparente

CE

EASY



7061TC € 7,20 1 070610001

7076BC

occhiali di protezione con lenti in policarbonato
trasparente

CE

SPORT



EN166F-1F
EN172
UV 5-3.1

7076BC € 16,50 1 070760009

7076BD

occhiali di protezione con lenti in policarbonato
scuro

CE

SPORT



EN166F-1F
EN170
UV 5-2.5

7076BD € 16,50 1 070760019

7076BP

occhiali di protezione con lenti in policarbonato
polarizzato scuro

CE

SPORT



EN12312-1

7076BP € 26,00 1 070760029

7076BU

occhiali per la ricerca di fughe con lampada UV

CE



EN12312-1

7076BU € 13,50 1 070760039

7093BC

occhiali di protezione con lenti in policarbonato trasparente

CE

IMPACT



EN166F-1F
EN170
UV400

7093BC € 24,50 1 070930009

7093BD

occhiali di protezione con lenti in policarbonato scuro

CE

IMPACT



EN166F-1F
EN172
UV5-2.5

7093BD € 24,50 1 070930019



C62M/W

espositore a manichino



185 cm

65 cm

C62M/W € 435,00 1 062000360

C63 E/W

espositore abbigliamento e calzature



2250 mm

515 mm

1010 mm

C63E/W € 1.020,00 1 063000010

C63 G/C

gondola espositiva calzature



1010 mm

515 mm

1010 mm

C63G/C € 735,00 1 063000020

6200AP/S10

set da 10 grucce



6200AP/S10 € 35,00 1 062000331

9562TB

tappeto prova calzature, con retro gommato antiscivolo



600 mm

800 mm

9562TB € 38,50 1 095620500





Robur

Dal 1930, Robur produce linee di accessori per funi allineandosi alla riconosciuta qualità di Beta Utensili, di cui è complemento produttivo.

Esperienza, organizzazione e tecnologia sono i requisiti di un continuo sviluppo determinato dall'attenzione alle esigenze del mercato.

Dal 1984, Robur ha sede in un moderno stabilimento a Sulmona.

 **Confezioni speciali per libero servizio**

CARICHI

WLL: carico massimo di esercizio (per accessori di sollevamento)

WFL: forza limite di lavoro (per accessori non destinati al sollevamento)

BF: forza massima raggiunta dall'articolo durante la prova di trazione statica

LC: tensione di ancoraggio

8049A

novità 2021

golfari maschio di sollevamento a doppia articolazione, girevole sotto carico con anello saldato in acciaio legato ad alta resistenza

CE



DATI TECNICI

- coefficiente di sicurezza: 4
 - trattamento termico: bonifica
 - codice lotto fabbricazione
- ANALISI DI LABORATORIO**
- analisi chimica • analisi metallografica
 - test di trazione
 - test di fatica (20.000 cicli)
 - carico di collaudo (100% del lotto)
- CERTIFICATI DISPONIBILI**
- Specifica Prodotto
 - Rapporto di Prova tipo 2.2 UNI EN10204
 - Certificato di Controllo tipo 3.1 UNI EN10204
 - Dichiarazione di Conformità CE

misura

	Ø mm	E mm	A mm	WLL kg	€		
M8	13	30	300	45,00	1	080490108	
M10	19	30	450	48,00	1	080490110	
M12	19	30	500	51,00	1	080490112	
M16	20	30	1120	55,00	1	080490116	
M20	30	40	2000	72,00	1	080490120	
M24	30	40	3150	104,00	1	080490124	
M30	35	50	5300	168,00	1	080490130	

prezzo unitario

numero codice

numero utensili nella confezione

8105

tenditori a due occhi ad alta resistenza
zincati a caldo

CE



DATI TECNICI

- coefficiente di sicurezza: 5
- trattamento termico canala: normalizzazione
- trattamento termico anelli: bonifica
- codice lotto di fabbricazione

ANALISI DI LABORATORIO

- analisi chimica
- test di trazione
- carico di collaudo 2 x WFL

CERTIFICATI DISPONIBILI

- Specifica Prodotto
- Rapporto di Prova tipo 2.2 UNI EN10204
- Certificato di Controllo tipo 3.1 UNI EN10204
- Dichiarazione di Conformità CE

ØxE	≈	WFL	€		
"	mm	kg			
3/8x6	M10x150	540	11,00	5	081050010
1/2x6	M12x150	1000	18,00	5	081050011
1/2x9	M12x230	1000	22,90	5	081050012
5/8x9	M16x230	1590	34,50	2	081050016
5/8x12	M16x300	1590	41,00	2	081050015
3/4x6	M20x150	2360	44,50	2	081050017
3/4x9	M20x230	2360	51,50	2	081050020
3/4x12	M20x300	2360	61,50	2	081050018
3/4x18	M20x460	2360	81,00	2	081050021
7/8x12	M22x300	3270	87,00	1	081050022
1x6	M24x150	4540	92,50	1	081050024
1x12	M24x300	4540	132,50	1	081050025
1.1/4x12	M33x300	6900	226,00	1	081050031
1.1/4x18	M33x460	6900	233,00	1	081050032
1.1/2x12	M39x300	9710	280,00	1	081050034
1.1/2x18	M39x460	9710	340,00	1	081050035
1.3/4x18	M45x460	12700	515,00	1	081050036

confezioni appendibili

ØxE	€		
"			
3/8x6	12,00	1	081059010
1/2x9	24,00	1	081059012

8109

tenditori a due forcelle ad alta resistenza
zincati a caldo

CE



DATI TECNICI

- coefficiente di sicurezza: 5
- trattamento termico canala: normalizzazione
- trattamento termico anelli: bonifica
- codice lotto di fabbricazione

ANALISI DI LABORATORIO

- analisi chimica
- test di trazione

CERTIFICATI DISPONIBILI

- Specifica Prodotto
- Rapporto di Prova tipo 2.2 UNI EN10204
- Certificato di Controllo tipo 3.1 UNI EN10204
- Dichiarazione di Conformità CE

ØxE	≈	WFL	€		
"	mm	kg			
3/8x6	M10x150	540	14,20	5	081090010
1/2x6	M12x150	1000	23,30	5	081090011
1/2x9	M12x230	1000	28,00	5	081090012
1/2x12	M12x300	1000	35,50	5	081090013
5/8x6	M16x150	1590	43,50	2	081090015

ØxE	≈	WFL	€		
"	mm	kg			
5/8x9	M16x230	1590	51,00	2	081090016
5/8x12	M16x300	1590	57,50	2	081090017
3/4x6	M20x150	2360	60,50	2	081090018
3/4x9	M20x230	2360	70,00	2	081090020
3/4x12	M20x300	2360	77,50	2	081090019
3/4x18	M20x460	2360	93,00	2	081090021
7/8x12	M22x300	3270	116,50	1	081090022
7/8x18	M22x460	3270	141,00	1	081090023
1x6	M24x150	4540	115,50	1	081090024
1x12	M24x300	4540	165,50	1	081090025
1x18	M24x460	4540	191,00	1	081090026
* 1.1/4x12	M33x300	6900	270,00	1	081090031
* 1.1/4x18	M33x460	6900	302,00	1	081090032
* 1.1/4x24	M33x610	6900	418,00	1	081090033
* 1.1/2x12	M39x300	9710	391,00	1	081090034
* 1.3/4x18	M45x460	12700	651,00	1	081090036
* 1.1/2x18	M39x460	9710	447,00	1	081090038
* 1.1/2x24	M39x610	9710	535,00	1	081090039

* forcella con perno passante e copiglia

confezioni appendibili

ØxE	€		
"			
3/8x6	15,20	1	081099010
1/2x9	29,00	1	081099012

8110

tenditori ad occhio e forcella ad alta resistenza
zincati a caldo

CE



DATI TECNICI

- coefficiente di sicurezza: 5
- trattamento termico canala: normalizzazione
- trattamento termico anelli: bonifica
- codice lotto di fabbricazione

ANALISI DI LABORATORIO

- analisi chimica
- test di trazione

CERTIFICATI DISPONIBILI

- Specifica Prodotto
- Rapporto di Prova tipo 2.2 UNI EN10204
- Certificato di Controllo tipo 3.1 UNI EN10204
- Dichiarazione di Conformità CE

ØxE	≈	WFL	€		
"	mm	kg			
1/2x9	M12x230	1000	25,50	5	081100010
5/8x12	M16x300	1590	48,50	2	081100016
3/4x6	M20x150	2360	53,00	2	081100019
3/4x9	M20x230	2360	61,00	2	081100020
3/4x12	M20x300	2360	69,50	2	081100021
7/8x12	M22x300	3270	102,00	1	081100022
1x6	M24x150	4540	104,00	1	081100027
1x12	M24x300	4540	149,00	1	081100029
* 1.1/4x12	M33x300	6900	248,00	1	081100034
* 1.1/2x12	M39x300	9710	348,00	1	081100038
* 1.1/2x18	M39x460	9710	395,00	1	081100039
* 1.3/4x18	M45x460	12700	603,00	1	081100044

* forcella con perno passante e copiglia

Robur

8005Z

tenditori a due occhi
zincati

CE

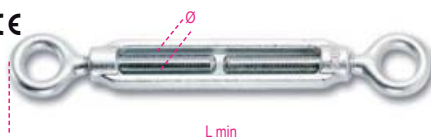

DATI TECNICI

- coefficiente di sicurezza: 4

ANALISI DI LABORATORIO

- analisi chimica
- test di trazione

CERTIFICATI DISPONIBILI

- Specifica Prodotto
- Rapporto di Prova tipo 2.2 UNI EN10204
- Dichiarazione di Conformità CE

Ø	≈	L min	WFL	€		
mm		mm	kg			
M5	3/16	118	115	1,80	400	080050105
M6	1/4	130	160	2,10	300	080050106
M8	5/16	158	300	3,20	200	080050108
M10	3/8	192	470	4,60	100	080050110
M11	7/16	206	580	6,10	80	080050111
M12	1/2	226	690	6,90	60	080050112
M14	9/16	256	940	9,50	15	080050114
M16	5/8	290	1290	14,20	10	080050116
M18	11/16	358	1660	22,30	1	080050118
M20	3/4	358	2130	24,50	1	080050120
M22	7/8	400	2630	32,50	1	080050122
M24	1"	436	3060	40,50	1	080050124
M27	1 1/8	474	4000	58,50	1	080050125
M30	1 3/16	498	4860	70,50	1	080050130
M33	1 1/4	516	6040	81,00	1	080050126
M36	1 3/8	532	6500	102,00	1	080050136
M39	1 1/2	544	7900	121,00	1	080050139

confezioni speciali

Ø	€		
mm			
M5	56,50	1	080050705
M6	61,50	1	080050706
M8	63,00	1	080050708
M10	67,50	1	080050710
M11	90,00	1	080050711
M12	105,00	1	080050712

confezioni appendibili

Ø	€		
mm			
M5	4,35	1	080059305
M6	4,85	1	080059306
M8	4,05	1	080059108
M10	5,40	1	080059110
M11	7,00	1	080059111
M12	7,80	1	080059112
M14	10,00	1	080059114
M16	14,90	1	080059116

Robur

8005TZ

tenditori a due occhi FORGIATI A CALDO
canala a tubo DIN 1478
zincati

CE



DATI TECNICI

- coefficiente di sicurezza: 4
- ANALISI DI LABORATORIO
- analisi chimica
- test di trazione
- CERTIFICATI DISPONIBILI
- Specifica Prodotto
- Rapporto di Prova tipo 2.2 UNI EN10204
- Dichiarazione di Conformità CE

Ø mm	≈	WFL kg	€	📦	🚚
M12	1/2	690	9,40	15	080050512
M16	5/8	1290	15,80	1	080050516
M20	3/4	2130	24,90	1	080050520
M24	1"	3060	43,00	1	080050524
M27	1.1/8	4000	58,00	1	080050527
M30	1.3/16	4860	67,00	1	080050530
M36	1.3/8	6500	110,00	1	080050536

confezioni appendibili

Ø mm	📦	€	🚚
M12	1	11,00	1

8006Z

tenditori ad occhio e gancio
zincati

CE

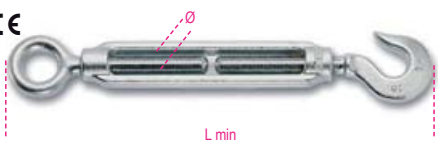

DATI TECNICI

- coefficiente di sicurezza: 4
- ANALISI DI LABORATORIO
- analisi chimica
- test di trazione
- CERTIFICATI DISPONIBILI
- Specifica Prodotto
- Rapporto di Prova tipo 2.2 UNI EN10204
- Dichiarazione di Conformità CE

Ø mm	≈	L min mm	WFL kg	€	📦	🚚
M5	3/16	121	25	1,90	400	080060105
M6	1/4	132	45	2,10	250	080060106
M8	5/16	170	95	3,25	180	080060108
M10	3/8	204	140	4,70	100	080060110
M11	7/16	221	165	6,40	15	080060111
M12	1/2	244	300	7,40	15	080060112
M14	9/16	284	420	10,90	10	080060114
M16	5/8	322	570	16,40	1	080060116
M18	11/16	373	700	24,00	1	080060118
M20	3/4	391	900	29,00	1	080060120
M22	7/8	433	1100	37,50	1	080060122
M24	1"	470	1300	50,50	1	080060124
M27	1.1/8	503	2300	68,50	1	080060127

confezioni speciali

Ø mm	≈	📦	€	🚚
M5	3/16	30	59,50	1
M6	1/4	30	65,50	1
M8	5/16	20	66,50	1
M10	3/8	15	73,50	1

confezioni appendibili

Ø mm	📦	€	🚚
M5	2	4,80	1
M6	2	5,45	1
M8	1	4,15	1
M10	1	5,70	1
M11	1	7,30	1
M12	1	8,30	1
M14	1	11,80	1

8007Z

tenditori a due ganci
zincati

CE

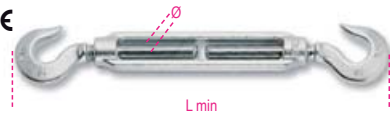

DATI TECNICI

- coefficiente di sicurezza: 4
- ANALISI DI LABORATORIO
- analisi chimica
- test di trazione
- CERTIFICATI DISPONIBILI
- Specifica Prodotto
- Rapporto di Prova tipo 2.2 UNI EN10204
- Dichiarazione di Conformità CE

Ø mm	≈	L min mm	WFL kg	€	📦	🚚
M5	3/16	124	25	2,10	30	080070105
M6	1/4	134	45	2,30	30	080070106
M8	5/16	181	95	3,40	20	080070108
M10	3/8	211	140	5,00	15	080070110
M11	7/16	231	165	6,80	15	080070111
M12	1/2	262	300	8,10	15	080070112
M14	9/16	312	420	12,30	1	080070114
M16	5/8	354	570	18,40	1	080070116
M18	11/16	388	700	26,00	1	080070118
M20	3/4	424	900	33,00	1	080070120
M22	7/8	466	1100	41,50	1	080070122
M24	1"	504	1300	58,50	1	080070124
M27	1.1/8	532	2300	75,50	1	080070127

confezioni appendibili

Ø mm	📦	€	🚚
M5	2	5,10	1
M6	2	5,45	1
M8	1	4,10	1
M10	1	5,60	1
M11	1	7,50	1
M12	1	8,90	1

8008N

tenditori a due tronchi
neri

CE

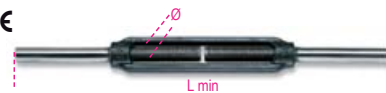

DATI TECNICI

- coefficiente di sicurezza: 4
- ANALISI DI LABORATORIO
- analisi chimica
- test di trazione
- CERTIFICATI DISPONIBILI
- Specifica Prodotto
- Rapporto di Prova tipo 2.2 UNI EN10204
- Dichiarazione di Conformità CE

Ø mm	≈	L min mm	WFL kg	€	📦	🚚
M5	3/16	160	115	1,75	30	080080205
M6	1/4	180	160	1,80	30	080080206
M8	5/16	210	300	2,60	20	080080208
M10	3/8	250	470	3,70	15	080080210
M12	1/2	280	690	5,05	15	080080212
M14	9/16	340	940	7,30	5	080080214
M16	5/8	380	1290	10,00	5	080080216
M18	11/16	410	1660	15,20	3	080080218
M20	3/4	440	2130	17,80	3	080080220
M22	7/8	480	2630	24,00	2	080080222
M24	1"	520	3060	28,00	2	080080224
M27	1.1/8	560	4000	46,00	1	080080227
M30	1.3/16	560	4860	57,50	1	080080230
M33	1.1/4	600	6040	61,00	1	080080233
M36*	1.3/8	600	6500	77,00	1	080080236
M39*	1.1/2	600	7900	89,00	1	080080239

confezioni appendibili

Ø mm	📦	€	🚚
M5	2	4,90	1
M6	2	5,00	1
M8	1	3,70	1
M10	1	4,80	1
M12	1	6,15	1
M14	1	8,70	1

8008TZN

tenditori a due tronchi
canala a tubo DIN 1478
terminali neri, corpo zincato

CE



DATI TECNICI

- coefficiente di sicurezza: 4
- ANALISI DI LABORATORIO
- analisi chimica
- test di trazione
- CERTIFICATI DISPONIBILI
- Specifica Prodotto
- Rapporto di Prova tipo 2.2 UNI EN10204
- Dichiarazione di Conformità CE

Ø mm	≈	WFL kg	€	📦	🚚
M12	1/2	690	6,90	10	080080512
M16	5/8	1290	12,30	1	080080516
M20	3/4	2130	18,40	1	080080520
M24	1	3060	31,00	1	080080524
M27	1.1/8	4000	47,00	1	080080527
M30	1.3/16	4860	54,00	1	080080530
M36	1.3/8	6500	88,00	1	080080536

8009Z

tenditori a due forcelle
zincati



DATI TECNICI

- coefficiente di sicurezza: 4
- ANALISI DI LABORATORIO
- analisi chimica
- test di trazione
- CERTIFICATI DISPONIBILI
- Specifica Prodotto
- Rapporto di Prova tipo 2.2 UNI EN10204
- Dichiarazione di Conformità CE

Ø mm	≈	L min mm	WFL kg	€	📦	🚚
M8	5/16	192	300	10,40	15	080090008
M10	3/8	234	470	12,20	15	080090010
M12	1/2	274	690	17,50	15	080090012
M14	9/16	342	940	24,50	1	080090014
M16	5/8	372	1290	29,50	1	080090016
M18	11/16	406	1660	41,50	1	080090018
M20	3/4	406	2130	44,50	1	080090020
M22	7/8	466	2630	60,50	1	080090022
M24	1"	486	3060	68,00	1	080090024
M27	1 1/8	510	4000	105,00	1	080090027
M30	1 3/16	566	4860	135,00	1	080090030

confezioni appendibili



Ø mm	📦	€	🚚
M8	1	11,40	1
M10	1	13,00	1
M12	1	17,50	1

8009TZ

tenditori a due forcelle
canaula a tubo DIN 1478
zincati



DATI TECNICI

- coefficiente di sicurezza: 4
- ANALISI DI LABORATORIO
- analisi chimica
- test di trazione
- CERTIFICATI DISPONIBILI
- Specifica Prodotto
- Rapporto di Prova tipo 2.2 UNI EN10204
- Dichiarazione di Conformità CE

Ø mm	≈	WFL kg	€	📦	🚚
M12	1/2	690	16,40	10	080090512
M16	5/8	1290	28,00	1	080090516
M20	3/4	2130	39,50	1	080090520
M24	1	3060	62,00	1	080090524
M27	1.1/8	4000	86,00	1	080090527
M30	1.3/16	4860	111,00	1	080090530

confezioni appendibili



Ø mm	📦	€	🚚
M12	1	18,00	1

8010Z

tenditori ad occhio e forcella
zincati



DATI TECNICI

- coefficiente di sicurezza: 4
- ANALISI DI LABORATORIO
- analisi chimica
- test di trazione
- CERTIFICATI DISPONIBILI
- Specifica Prodotto
- Rapporto di Prova tipo 2.2 UNI EN10204
- Dichiarazione di Conformità CE

Ø mm	≈	L min mm	WFL kg	€	📦	🚚
M8	5/16	175	300	6,20	20	080100008
M10	3/8	215	470	7,90	15	080100010
M12	1/2	250	690	11,70	10	080100012
M14	9/16	299	940	16,20	10	080100014
M16	5/8	331	1290	21,30	1	080100016
M18	11/16	382	1660	32,00	1	080100018
M20	3/4	382	2130	35,00	1	080100020
M22	7/8	433	2630	47,50	1	080100022
M24	1"	461	3060	55,50	1	080100024
M27	1 1/8	492	4000	82,00	1	080100027
M30	1 3/16	529	4860	105,00	1	080100030

confezioni appendibili



Ø mm	📦	€	🚚
M8	1	7,40	1
M10	1	9,10	1
M12	1	12,40	1
M14	1	17,50	1

8010TZ

tenditori ad occhio e forcella
canaula a tubo DIN 1478
zincati



DATI TECNICI

- coefficiente di sicurezza: 4
- ANALISI DI LABORATORIO
- analisi chimica
- test di trazione
- CERTIFICATI DISPONIBILI
- Specifica Prodotto
- Rapporto di Prova tipo 2.2 UNI EN10204
- Dichiarazione di Conformità CE

Ø mm	≈	WFL kg	€	📦	🚚
M12	1/2	690	12,80	10	080100612
M16	5/8	1290	22,50	1	080100616
M20	3/4	2130	33,50	1	080100620
M24	1	3060	55,00	1	080100624
M27	1.1/8	4000	76,50	1	080100627
M30	1.3/16	4860	93,00	1	080100630

8001Z

canaule per tenditori
zincate



DATI TECNICI

- coefficiente di sicurezza: 5
- codice lotto di fabbricazione
- ANALISI DI LABORATORIO
- analisi chimica
- test di trazione
- CERTIFICATI DISPONIBILI
- Specifica Prodotto
- Rapporto di Prova tipo 2.2 UNI EN10204
- Certificato di Controllo tipo 3.1 UNI EN10204
- Dichiarazione di Conformità CE

Ø mm	≈	L mm	WFL kg	€	📦	🚚
M5	3/16	80	115	1,10	100	080010105
M6	1/4	80	160	1,15	100	080010106
M8	5/16	105	300	1,80	25	080010108
M10	3/8	125	470	2,30	20	080010110
M11	7/16	135	580	2,90	15	080010111
M12	1/2	140	690	3,10	20	080010112
M14	9/16	170	940	4,40	15	080010114
M16	5/8	190	1290	5,90	15	080010116
M18	11/16	205	1660	9,40	10	080010118
M20	3/4	220	2130	10,80	10	080010120
M22	7/8	240	2630	13,80	8	080010122
M24	1"	260	3060	16,80	5	080010124
M27	1 1/8	270	4000	26,50	1	080010127
M30	1 3/16	280	4860	33,50	1	080010130
M33	1 1/4	290	6040	36,50	1	080010133
M36	1 3/8	300	6500	47,00	1	080010136
M39	1 1/2	300	7900	56,50	1	080010139

confezioni appendibili



Ø mm	📦	€	🚚
M5	2	3,30	1
M6	2	3,60	1
M8	1	2,90	1
M10	1	3,35	1
M11	1	4,00	1
M12	1	4,20	1
M14	1	5,60	1
M16	1	7,10	1
M18	1	10,50	1
M20	1	11,80	1
M22	1	14,80	1
M24	1	17,90	1



8001TZ

canaile a tubo per tenditori
zincate

CE



DIN 1478

DATI TECNICI

- coefficiente di sicurezza: 5
- codice lotto di fabbricazione

ANALISI DI LABORATORIO

- analisi chimica
- test di trazione

CERTIFICATI DISPONIBILI

- Specifica Prodotto
- Rapporto di Prova tipo 2.2 UNI EN10204
- Certificato di Controllo tipo 3.1 UNI EN10204
- Dichiarazione di Conformità CE

Ø mm	≈ "	L mm	WFL kg	€	📦	🚚
M12	1/2	125	690	5,10	10	080010512
M16	5/8	170	1290	7,80	5	080010516
M20	3/4	200	2130	10,30	5	080010520
M24	1	255	3060	18,00	3	080010524
* M27	1 1/8	255	4000	24,30	1	080010527
M30	1.3/16	255	4860	27,50	1	080010530
M36	1.3/8	295	6500	49,00	1	080010536
M42	1.5/8	330	9700	70,00	1	080010542

* misure non contemplate nella norma.

da M12 a M27 acciaio S235JR
da M30 a M42 acciaio S355JR

confezioni appendibili



Ø mm	📦	€	🚚
M12	1	6,10	1 080019512
M16	1	8,70	1 080019516
M20	1	11,30	1 080019520
M24	1	18,80	1 080019524

8002ZD

anelli per tenditori,
filettatura destra, zincati

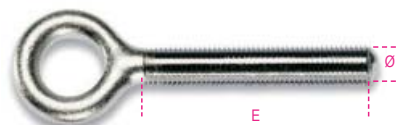

DATI TECNICI

- coefficiente di sicurezza: 4

ANALISI DI LABORATORIO

- analisi chimica
- test di trazione

CERTIFICATI DISPONIBILI

- Specifica Prodotto
- Rapporto di Prova tipo 2.2 UNI EN10204

Ø mm	≈ "	E mm	WFL kg	€	📦	🚚
M5	3/16	37	115	0,39	200	080020105
M6	1/4	40	160	0,45	150	080020106
M8	5/16	52	300	0,68	100	080020108
M10	3/8	60	470	1,10	100	080020110
M11	7/16	65	580	1,55	1	080020111
M12	1/2	72	690	1,95	50	080020112
M14	9/16	85	940	2,40	1	080020114
M16	5/8	95	1290	4,00	1	080020116
M18	11/16	103	1660	5,90	1	080020118
M20	3/4	110	2130	6,60	1	080020120
M22	7/8	120	2630	9,50	1	080020122
M24	1"	130	3060	12,20	1	080020124
M27	1 1/8	135	4000	16,90	1	080020127
M30	1 3/16	140	4860	19,70	1	080020130
M33	1 1/4	148	6040	23,80	1	080020133
M36	1 3/8	150	6500	29,50	1	080020136
M39	1 1/2	150	7900	34,00	1	080020139

filetto sinistrorso

Ø mm	≈ "	E mm	WFL kg	€	📦	🚚
M5	3/16	37	115	0,39	1	080020305
M6	1/4	40	160	0,45	1	080020306
M8	5/16	52	300	0,68	1	080020308
M10	3/8	60	470	1,10	1	080020310
M11	7/16	65	580	1,55	1	080020311
M12	1/2	72	690	1,95	1	080020312
M14	9/16	85	940	2,40	1	080020314
M16	5/8	95	1290	4,00	1	080020316
M18	11/16	103	1660	5,90	1	080020318
M20	3/4	110	2130	6,60	1	080020320
M22	7/8	120	2630	9,50	1	080020322
M24	1"	130	3060	12,20	1	080020324
M27	1 1/8	135	4000	16,90	1	080020327
M30	1 3/16	140	4860	19,70	1	080020330
M33	1 1/4	148	6040	23,80	1	080020333
M36	1 3/8	150	6500	29,50	1	080020336
M39	1 1/2	150	7900	34,00	1	080020339

8003ZD

ganci per tenditori,
filettatura destra, zincati



DATI TECNICI

- coefficiente di sicurezza: 4

ANALISI DI LABORATORIO

- analisi chimica
- test di trazione

CERTIFICATI DISPONIBILI

- Specifica Prodotto
- Rapporto di Prova tipo 2.2 UNI EN10204

Ø mm	≈ "	E mm	WFL kg	€	📦	🚚
M5	3/16	40	25	0,50	150	080030105
M6	1/4	40	45	0,58	120	080030106
M8	5/16	52	95	0,85	100	080030108
M10	3/8	60	140	1,50	70	080030110
M11	7/16	65	165	2,05	1	080030111
M12	1/2	70	300	2,65	30	080030112
M14	9/16	85	420	4,00	1	080030114
M16	5/8	95	570	6,05	1	080030116
M18	11/16	103	700	8,10	1	080030118
M20	3/4	110	900	11,00	1	080030120
M22	7/8	120	1100	14,20	1	080030122
M24	1"	130	1300	21,80	1	080030124
M27	1 1/8	135	2300	26,00	1	080030127

filetto sinistrorso

Ø mm	≈ "	WFL kg	E mm	€	📦	🚚
M5	3/16	40	25	0,50	1	080030305
M6	1/4	40	45	0,58	1	080030306
M8	5/16	52	95	0,85	1	080030308
M10	3/8	60	140	1,50	1	080030310
M11	7/16	65	165	2,05	1	080030311
M12	1/2	70	300	2,65	1	080030312
M14	9/16	85	420	4,00	1	080030314
M16	5/8	95	570	6,05	1	080030316
M18	11/16	103	700	8,10	1	080030318
M20	3/4	110	900	11,00	1	080030320
M22	7/8	120	1100	14,20	1	080030322
M24	1"	130	1300	21,80	1	080030324
M27	1 1/8	135	2300	26,00	1	080030327

8004ND

tronchi per tenditori
destri - neri



DATI TECNICI

- coefficiente di sicurezza: 4

ANALISI DI LABORATORIO

- analisi chimica
- test di trazione

CERTIFICATI DISPONIBILI

- Specifica Prodotto
- Rapporto di Prova tipo 2.2 UNI EN10204

Ø mm	≈ "	E mm	WFL kg	€	📦	🚚
M5	3/16	40	115	0,40	1	080040005
M6	1/4	44	160	0,45	1	080040006
M8	5/16	53	300	0,55	1	080040008
M10	3/8	63	470	0,80	1	080040010
M12	1/2	70	690	1,35	1	080040012
M14	9/16	85	940	1,85	1	080040014
M16	5/8	95	1290	2,55	1	080040016
M18	11/16	103	1660	3,45	1	080040018
M20	3/4	110	2130	4,40	1	080040020
M22	7/8	120	2630	5,40	1	080040022
M24	1"	130	3060	7,60	1	080040024
M27	1 1/8	135	4000	12,10	1	080040027
M30	1 3/16	140	4860	15,00	1	080040030
M33	1 1/4	150	6040	15,50	1	080040033
M36	1 3/8	150	6500	20,50	1	080040036
M39	1 1/2	150	7900	22,50	1	080040039

filetto sinistrorso

Ø mm	≈ "	E mm	WFL kg	€	📦	🚚
M5	3/16	40	115	0,40	1	080040105
M6	1/4	44	160	0,45	1	080040106
M8	5/16	53	300	0,55	1	080040108
M10	3/8	63	470	0,80	1	080040110
M12	1/2	70	690	1,35	1	080040112
M14	9/16	85	940	1,85	1	080040114
M16	5/8	95	1290	2,55	1	080040116
M18	11/16	103	1660	3,45	1	080040118
M20	3/4	110	2130	4,40	1	080040120
M22	7/8	120	2630	5,40	1	080040122
M24	1"	130	3060	7,60	1	080040124
M27	1 1/8	135	4000	12,10	1	080040127
M30	1 3/16	140	4860	15,00	1	080040130
M33	1 1/4	150	6040	15,50	1	080040133
M36	1 3/8	150	6500	20,50	1	080040136
M39	1 1/2	150	7900	22,50	1	080040139



8009FD

forcelle per tenditori
destre - zincate

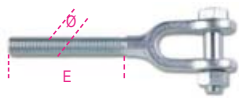

DATI TECNICI

• coefficiente di sicurezza: 4

ANALISI DI LABORATORIO

• analisi chimica

• test di trazione

CERTIFICATI DISPONIBILI

• Specifica Prodotto

• Rapporto di Prova tipo 2.2 UNI EN10204

Ø mm	≈ "	E mm	WFL kg	€		
M8	5/16	53	300	4,30	1	080090208
M10	3/8	63	470	5,00	1	080090210
M12	1/2	70	690	6,80	1	080090212
M14	9/16	85	940	9,40	1	080090214
M16	5/8	95	1290	10,70	1	080090216
M18	11/16	103	1660	15,00	1	080090218
M20	3/4	110	2130	15,50	1	080090220
M22	7/8	120	2630	22,50	1	080090222
M24	1"	130	3060	25,50	1	080090224
M27	1 1/8	135	4000	40,00	1	080090227
M30	1 3/16	140	4860	52,00	1	080090230

filetto sinistrorso

Ø mm	≈ "	E mm	WFL kg	€		
M8	5/16	53	300	4,30	1	080090408
M10	3/8	63	470	5,00	1	080090410
M12	1/2	70	690	6,80	1	080090412
M14	9/16	85	940	9,40	1	080090414
M16	5/8	95	1290	10,70	1	080090416
M18	11/16	103	1660	15,00	1	080090418
M20	3/4	110	2130	15,50	1	080090420
M22	7/8	120	2630	22,50	1	080090422
M24	1"	130	3060	25,50	1	080090424
M27	1 1/8	135	4000	40,00	1	080090427
M30	1 3/16	140	4860	52,00	1	080090430

8048

tiranti ad occhio
destri
neri



UNI 6058

ØxL mm	WFL kg	F mm	€		
M8x50	430	6	2,70	1	080480108
M8x65	430	6	2,90	1	080480109
M10x80	690	8	4,50	1	080480110
M10x100	690	8	4,50	1	080480210
M10x130	690	8	5,00	1	080480111
M12x70	1020	10	4,60	1	080480212
M12x95	1020	10	4,70	1	080480112
M12x125	1020	10	5,80	1	080480113
M14x110	1420	12	6,50	1	080480114
M16x100	1980	14	5,40	1	080480115
M16x130	1980	14	5,60	1	080480116
M18x150	2390	16	12,50	1	080480118
M20x160	3100	18	15,50	1	080480120
M22x180	3890	18	24,00	1	080480122
M24x200	4460	20	28,00	1	080480124
M24x220	4460	20	30,00	1	080480125
M27x220	5900	22	36,00	1	080480127

8302Z

viti ad occhio per tasselli
filettatura destra
zincate



DATI TECNICI

• coefficiente di sicurezza: 4

CERTIFICATI DISPONIBILI

• Specifica Prodotto

• Rapporto di Prova tipo 2.2 UNI EN10204

Ø mm	E mm	F mm	WFL kg	€		
M5	48	8	115	0,42	200	083020005
M6	55	10	160	0,52	150	083020006
M8	60	12	300	0,70	100	083020008
M10	73	14	470	1,20	100	083020010
M12	90	17	690	2,30	50	083020012

8303Z

ganci per tasselli
filettatura destra
zincati



DATI TECNICI

• coefficiente di sicurezza: 4

CERTIFICATI DISPONIBILI

• Specifica Prodotto

• Rapporto di Prova tipo 2.2 UNI EN10204

Ø mm	C mm	E mm	WFL kg	€		
M5	6,0	48	25	0,50	120	083030005
M6	8,0	55	45	0,55	100	083030006
M8	10,0	60	95	0,90	75	083030008
M10	12,5	73	140	1,50	50	083030010
M12	16,0	90	220	2,50	20	083030012

8702N

capicorda a pressare in acciaio forgiato
terminale ad occhio
neri



DATI TECNICI

• codice lotto di fabbricazione

ANALISI DI LABORATORIO

• analisi chimica

• test di trazione

CERTIFICATI DISPONIBILI

• Specifica Prodotto

• Rapporto di Prova tipo 2.2 UNI EN10204

• Certificato di Controllo tipo 3.1 UNI EN10204

M	Ø B mm	Ø A mm	Ø D mm	€		
6	6,8	13	19	36,00	1	087020106
8	8,8	20	22	44,00	1	087020108
10	10,8	20	22	44,00	1	087020110
11	11,8	25	27	54,00	1	087020111
12	12,8	25	27	54,00	1	087020112
13	13,8	25	27	54,00	1	087020113
14	14,8	32	32	75,00	1	087020114
15	15,9	32	32	75,00	1	087020115
16	17,0	32	32	75,00	1	087020116
18	19,0	39	37	97,00	1	087020118
19	20,0	39	37	97,00	1	087020119
20	21,1	39	37	97,00	1	087020120
24	25,4	50	52	155,00	1	087020124
25	26,4	50	52	155,00	1	087020125
26	27,4	50	52	155,00	1	087020126

La pressatura dei capicorda richiede presse e stampi idonei e può essere eseguita esclusivamente da personale specializzato.

8709N

capicorda a pressare in acciaio forgiato
terminale a forcella
neri



DATI TECNICI

• codice lotto di fabbricazione

ANALISI DI LABORATORIO

• analisi chimica

• test di trazione

CERTIFICATI DISPONIBILI

• Specifica Prodotto

• Rapporto di Prova tipo 2.2 UNI EN10204

• Certificato di Controllo tipo 3.1 UNI EN10204

M	Ø B mm	Ø A mm	Ø C mm	€		
6	6,8	13	17	49,00	1	087090106
8	8,8	20	21	64,00	1	087090108
10	10,8	20	21	64,00	1	087090110
11	11,8	25	25	80,00	1	087090111
12	12,8	25	25	80,00	1	087090112
13	13,8	25	25	80,00	1	087090113
14	14,8	32	30	112,00	1	087090114
15	15,9	32	30	112,00	1	087090115
16	17,0	32	30	112,00	1	087090116
18	19,0	39	35	145,00	1	087090118
19	20,0	39	35	145,00	1	087090119
20	21,1	39	35	145,00	1	087090120
24	25,4	50	51	190,00	1	087090124
25	26,4	50	51	190,00	1	087090125
26	27,4	50	51	190,00	1	087090126

La pressatura dei capicorda richiede presse e stampi idonei e può essere eseguita esclusivamente da personale specializzato.



8016

morsetti in acciaio
zincati

CE

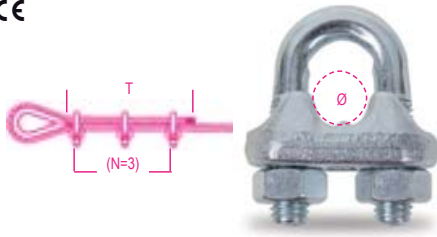

ANALISI DI LABORATORIO

- analisi chimica
- test coppia di serraggio
- CERTIFICATI DISPONIBILI
- Specifica Prodotto
- Rapporto di Prova tipo 2.2 UNI EN10204
- Certificato di Conformità CE

8016DA

morsetti in acciaio, dado alto
zincati

CE

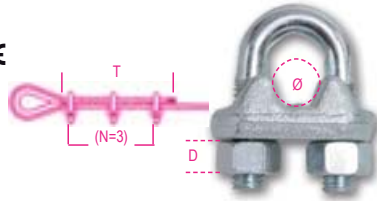

ANALISI DI LABORATORIO

- analisi chimica
- test coppia di serraggio
- CERTIFICATI DISPONIBILI
- Specifica Prodotto
- Rapporto di Prova tipo 2.2 UNI EN10204
- Certificato di Conformità CE

Ø mm	N x T mm	Nm	D mm	€	📦	📄
5	3x110	3,02	5	0,75	300	080160093
6	3x120	5,19	6	0,85	200	080160092
8	5x210	5,19	6	1,12	150	080160098
10	5x240	12,54	8	1,65	70	080160096

8016FR

morsetti in acciaio,
corpo stampato a freddo
zincati

CE

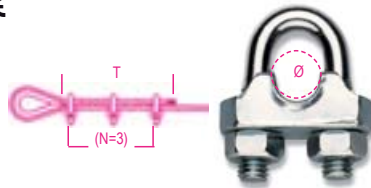

ANALISI DI LABORATORIO

- analisi chimica
- CERTIFICATI DISPONIBILI
- Specifica Prodotto
- Rapporto di Prova tipo 2.2 UNI EN10204
- Certificato di Conformità CE

Ø mm	Ø mm	N x T mm	Nm	€	📦	📄
3	1/8	3x80	1,25	0,44	500	080160253
5	3/16	3x110	2,46	0,54	300	080160255
6	1/4	3x120	4,24	0,65	200	080160256
8	5/16	5x210	4,24	0,75	150	080160258

confezioni appendibili

Ø mm	📦	€	📄
3	6	3,90	1 080169753
5	6	3,40	1 080169755
6	4	3,80	1 080169756
8	4	4,05	1 080169758

8018E

morsetti tipo ENEL, dado alto
corpo in acciaio zincato a caldo
cavallotti e dadi zincati e sigillati



ANALISI DI LABORATORIO

- analisi chimica
- CERTIFICATI DISPONIBILI
- Specifica Prodotto
- Rapporto di Prova tipo 2.2 UNI EN10204

Ø mm	A mm	L mm	Nm	€	📦	📄
4-6	M6	34	4,24	0,97	100	080180001

8016U2

morsetti
corpo in ghisa malleabile
zincati

CE

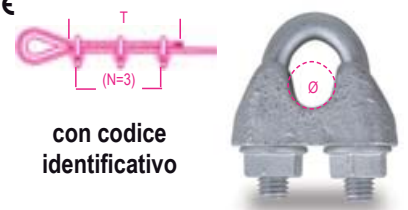

con codice
identificativo

dimensioni EN 13411-5 tipo A

DATI TECNICI

- codice di identificazione
- ANALISI DI LABORATORIO
- analisi chimica
- test coppia di serraggio
- CERTIFICATI DISPONIBILI
- Specifica Prodotto
- Rapporto di Prova tipo 2.2 UNI EN10204
- Certificato del Fabbricante UNI EN13411-5
- Dichiarazione di Conformità CE

Ø mm	Ø mm	N x T mm	Nm	€	📦	📄
5	3/16	3x156	2,0	0,26	300	080160855
6,5	1/4	3x192	3,5	0,37	150	080160856
8	5/16	4x320	6	0,73	70	080160858
10	3/8	4x320	9	0,76	60	080160860
12	1/2	4x384	20	1,45	25	080160862
14	9/16	4x448	33	2,25	15	080160864
16	5/8	4x512	49	3,35	10	080160866
19	3/4	4x512	68	3,90	10	080160869
22	7/8	5x680	107	5,60	10	080160872
26	1	5x760	147	10,00	5	080160876
30	1.1/8	6x984	212	12,90	5	080160880
34	1.1/4	6x1080	296	17,60	5	080160884
40	1.1/2	6x1176	363	22,00	5	080160890

confezioni appendibili

Ø mm	📦	€	📄
5	4	3,20	1 080169805
6	4	4,00	1 080169806
8	4	6,20	1 080169808
10	2	4,20	1 080169810
12	1	4,00	1 080169812
14	1	4,60	1 080169814
16	1	6,20	1 080169816
19	1	6,80	1 080169819
22	1	8,80	1 080169822
26	1	14,50	1 080169826

Ø mm	Ø "	N x T mm	Nm	€	📦	📄
3	1/8	3x80	1,53	0,48	500	080160003
5	3/16	3x110	3,02	0,62	300	080160005
6	1/4	3x120	5,19	0,68	200	080160006
8	5/16	5x210	5,19	0,85	150	080160008
10	3/8	5x240	12,54	1,27	70	080160010
11	7/16	5x260	12,54	1,38	70	080160011
12-13	1/2	5x300	24,76	1,84	40	080160013
14	9/16	5x295	24,76	2,00	35	080160014
16	5/8	5x335	24,76	2,35	30	080160016
18	11/16	5x380	42,42	3,20	30	080160018
20	3/4	5x540	42,42	3,45	30	080160020
22	7/8	7x595	42,42	4,00	25	080160022
24-26	1"	7x700	67,56	5,60	15	080160026
28	1"1/16	8x840	67,56	6,95	5	080160028
30-32	1"1/8	8x990	67,56	7,00	5	080160030
34-36	1"1/4	8x1155	105,80	9,20	4	080160034
38-40	1"1/2	8x1320	105,80	12,40	2	080160040
45-50	2"	8x1500	206	19,20	1	080160050

confezioni speciali

Ø mm	📦	€	📄
3	1/8 100	48,00	1 080160703
5	3/16 50	31,00	1 080160705
6	1/4 50	34,00	1 080160706
8	5/16 30	25,50	1 080160708
10	3/8 30	38,00	1 080160710
11	7/16 25	34,50	1 080160711
12-13	1/2 15	27,50	1 080160713

confezioni appendibili

Ø mm	📦	€	📄
3	6	3,65	1 080169403
5	4	3,25	1 080169405
6	4	3,60	1 080169406
8	4	4,20	1 080169408
10	2	3,35	1 080169410
11	1	2,45	1 080169011
12-13	1	2,90	1 080169013
14	1	3,05	1 080169014
16	1	3,35	1 080169016
18	1	4,30	1 080169018
20	1	4,40	1 080169020
22	1	5,10	1 080169022
24-26	1	6,70	1 080169026



8016UGK

morsetti
in ghisa malleabile
corpo ZINCATO A CALDO
cavalotto e dadi GEOMET-GEOKOTE

CE

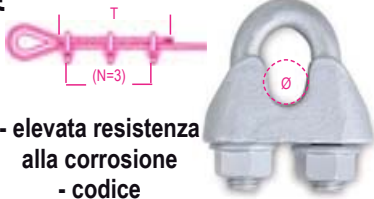

- elevata resistenza alla corrosione
- codice identificativo

dimensioni EN 13411-5 tipo A

DATI TECNICI

• codice di identificazione

ANALISI DI LABORATORIO

• analisi chimica

• test coppia di serraggio

CERTIFICATI DISPONIBILI

• Specifica Prodotto

• Rapporto di Prova tipo 2.2 UNI EN10204

• Certificato del Fabbricante UNI EN13411-5

• Dichiarazione di Conformità CE

Ø mm	Ø "	N x T	Nm	€		
8	5/16	4x320	6	1,45	70	080160758
10	3/8	4x320	9	1,60	60	080160760
12	1/2	4x448	33	2,90	25	080160762
14	9/16	4x384	20	4,20	15	080160764
16	5/8	4x512	49	6,20	10	080160766
19	3/4	4x512	68	7,00	10	080160769
22	7/8	5x680	107	10,00	10	080160772
26	1	5x760	147	16,50	5	080160776
30	1,1/8	6x984	212	20,00	1	080160780
34	1,1/4	6x1080	296	28,50	1	080160784
40	1,1/2	6x1176	363	35,00	1	080160790

8018T

morsetti tipo TELECOM,
corpo in ghisa malleabile
zincato a caldo



RUM-MU-21:1980

ANALISI DI LABORATORIO

• analisi chimica

CERTIFICATI DISPONIBILI

• Specifica Prodotto

• Rapporto di Prova tipo 2.2 UNI EN10204

Ø mm	A mm	L mm	Nm	€		
8÷10	M8	42	10,20	1,00	200	080180003

8020A

radance tipo leggero
zincate

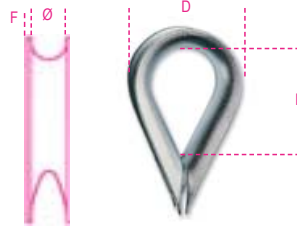

CERTIFICATI DISPONIBILI

• Specifica Prodotto

• Rapporto di Prova tipo 2.2 UNI EN10204

Ø mm	F mm	B mm	D mm	€		
2-3	1,0	20	18	0,18	150	080200503
4	1,2	23	19	0,19	150	080200504
5	1,2	24	23	0,22	100	080200505
6	1,2	27	28	0,23	100	080200506
8	1,4	33	32	0,36	50	080200508
10	1,8	41	38	0,52	30	080200510
12	2,2	44	45	0,68	30	080200512
14	2,2	52	49	0,88	50	080200514
16	3,0	58	58	1,22	50	080200516
18	3,7	64	68	1,62	50	080200518
20	3,7	73	74	2,25	35	080200520
22	3,7	83	79	2,50	30	080200522
24	3,7	93	88	3,30	20	080200525

8020

radance tipo leggero
zincate

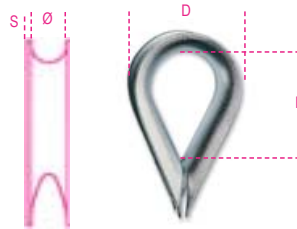

CERTIFICATI DISPONIBILI

• Specifica Prodotto

• Rapporto di Prova tipo 2.2 UNI EN10204

Ø mm	S mm	B mm	D mm	€		
2-3	0,8	20	20	0,18	350	080200003
4	1,0	22	21	0,19	300	080200004
5	1,0	23	24	0,22	300	080200005
6	1,0	27	29	0,23	200	080200006
8	1,2	33	33	0,36	180	080200008
10	1,5	40	39	0,52	100	080200010
12	1,8	44	46	0,68	120	080200012
14	2,0	49	50	0,88	100	080200014
16	2,0	57	59	1,22	150	080200016
18	2,5	68	69	1,62	100	080200018
20	3,0	78	77	2,25	70	080200020
22	3,0	88	84	2,50	60	080200022
24	3,5	92	91	3,30	40	080200025

confezioni speciali

Ø mm	S mm	€		
2-3	0,8	150	27,00	1 080200703
4	1,0	150	28,50	1 080200704
5	1,0	100	22,00	1 080200705
6	1,0	100	23,00	1 080200706
8	1,2	50	18,00	1 080200708
10	1,5	30	15,60	1 080200710

8021

radance tipo pesante
zincate

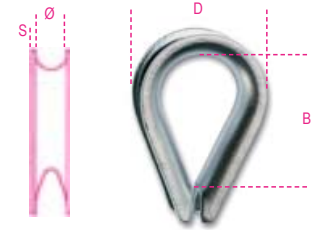

CERTIFICATI DISPONIBILI

• Specifica Prodotto

• Rapporto di Prova tipo 2.2 UNI EN10204

Ø mm	S mm	B mm	D mm	€		
2-3	0,6	15	16	0,29	150	080210003
5	1,7	29	28	0,42	120	080210005
6	1,8	33	30	0,46	100	080210006
8	2,5	36	37	0,64	100	080210008
10	2,5	42	43	0,78	80	080210010
12	2,5	48	50	1,00	100	080210012
14	2,7	58	57	1,35	70	080210014
16	3,0	61	62	1,65	50	080210016
18	3,5	71	71	2,15	70	080210018
20	4,0	79	79	3,20	60	080210020
22	4,0	87	84	3,70	50	080210022
24	4,0	93	92	4,40	40	080210024
26	4,0	103	103	5,40	35	080210026
28	5,0	107	116	12,50	1	080210028
30	5,0	118	121	12,50	1	080210030
32	5,5	138	135	15,00	1	080210032
35	6,0	140	147	21,00	1	080210035
40	6,0	173	170	30,00	1	080210040

8026R

grilli diritti per sollevamento, perno a vite,
acciaio legato ad alta resistenza
staffa zincata a caldo

CE

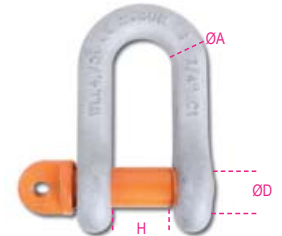

EN 13889

GRADE 6

DATI TECNICI

• coefficiente di sicurezza minimo: 6

• trattamento termico: bonifica

• codice lotto fabbricazione su perno e staffa

ANALISI DI LABORATORIO

• analisi chimica • analisi metallografica

• test di trazione • test di fatica (min.20.000 cicli)

• test carico di collaudo (2 x wll)

CERTIFICATI DISPONIBILI

• Specifica Prodotto

• Rapporto di Prova tipo 2.2 UNI EN10204

• Certificato di Controllo tipo 3.1 UNI EN10204

• Dichiarazione di Conformità CE

ØD mm	ØA mm	H mm	WLL kg	€		
16	13	21	2000	9,00	5	080260212
19	16	27	3250	15,30	3	080260216
22	19	32	4750	22,50	2	080260219
25	22	37	6500	34,00	2	080260222

confezioni appendibili

ØD mm	€		
16	9,80	1	080269212
19	16,50	1	080269216



8029R

grilli per sollevamento a lira, perno a vite
acciaio legato ad alta resistenza
staffa zincata a caldo

CE

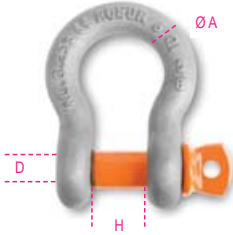

EN 13889
GRADO 6

DATI TECNICI

- coefficiente di sicurezza minimo: 6
- trattamento termico: bonifica
- codice lotto fabbricazione su perno e staffa

ANALISI DI LABORATORIO

- analisi chimica
- analisi metallografica
- test di trazione
- test di fatica (min.20.000 cicli)
- test carico di collaudo (2 x wll)

CERTIFICATI DISPONIBILI

- Specifica Prodotto
- Rapporto di Prova tipo 2.2 UNI EN10204
- Certificato di Controllo tipo 3.1 UNI EN10204
- Dichiarazione di Conformità CE

ØD mm	ØA mm	H mm	WLL kg	€	📦	📄
8	6	13	500	3,00	20	080290106
10	8	13,5	750	3,60	15	080290108
11	10	17	1000	5,10	15	080290110
13	11	18,5	1500	6,80	10	080290111
16	13	20,5	2000	7,00	8	080290112
19	16	27	3250	12,00	5	080290116
22	19	32	4750	17,50	2	080290120
25	22	37	6500	26,50	2	080290122
28	26	43,5	8500	36,00	1	080290124
32	29	48	9500	67,50	1	080290128
35	32	53	12000	90,00	1	080290132
38	35	59	13500	119,00	1	080290135
42	38	62	17000	155,00	1	080290138
50	45	75	25000	265,00	1	080290145
57	50	83	35000	465,00	1	080290150
65	57	95	42500	800,00	1	080290157
70	65	105	55000	915,00	1	080290165

confezioni appendibili



ØD mm	📦	€	📄
8	1	4,00	080299106
10	1	4,60	080299108
11	1	6,20	080299110
13	1	7,90	080299111
16	1	8,00	080299112
19	1	13,50	080299116



8031R

grilli per sollevamento a lira con dado e
copiglia
acciaio legato ad alta resistenza
staffa zincata a caldo

CE



EN 13889
GRADO 6

DATI TECNICI

- coefficiente di sicurezza minimo: 6
- trattamento termico: bonifica
- codice lotto fabbricazione su perno e staffa

ANALISI DI LABORATORIO

- analisi chimica
- analisi metallografica
- test di trazione
- test di fatica (min.20.000 cicli)
- test carico di collaudo (2 x wll)

CERTIFICATI DISPONIBILI

- Specifica Prodotto
- Rapporto di Prova tipo 2.2 UNI EN10204
- Certificato di Controllo tipo 3.1 UNI EN10204
- Dichiarazione di Conformità CE

ØD mm	ØA mm	H mm	WLL kg	€	📦	📄
13	11	18	1500	8,50	5	080310111
16	13	21	2000	8,70	5	080310112
19	16	27	3250	14,70	3	080310116
22	19	32	4750	21,00	2	080310120
25	22	37	6500	29,50	2	080310122
28	26	43	8500	43,50	1	080310124
32	29	48	9500	74,00	1	080310128
35	32	53	12000	96,00	1	080310132
38	35	59	13500	135,00	1	080310135
42	38	62	17000	164,00	1	080310138
50	45	75	25000	288,00	1	080310145
57	50	83	35000	505,00	1	080310150
70	65	105	55000	1.030,00	1	080310165
83	75	127	85000	1.565,00	1	080310183

confezioni appendibili



ØD mm	📦	€	📄
16	1	10,70	080319112
19	1	18,00	080319116

8032

grilli a lira per sollevamento, perno a foro
quadro
acciaio legato ad alta resistenza
staffa zincata a caldo

CE

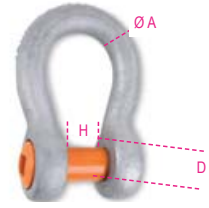

GRADE 6

DATI TECNICI

- coefficiente di sicurezza minimo: 6
- trattamento termico: bonifica
- codice lotto fabbricazione su perno e staffa

ANALISI DI LABORATORIO

- analisi chimica
- analisi metallografica
- test di trazione
- test di fatica (min.20.000 cicli)
- test carico di collaudo (2 x wll)

CERTIFICATI DISPONIBILI

- Specifica Prodotto
- Rapporto di Prova tipo 2.2 UNI EN10204
- Certificato di Controllo tipo 3.1 UNI EN10204
- Dichiarazione di Conformità CE

ØD mm	ØA mm	H mm	WLL kg	€	📦	📄
16	13	21	2000	8,30	5	080320012
19	16	27	3250	14,90	3	080320016
22	19	32	4750	26,00	2	080320020
25	22	37	6500	38,00	2	080320022

confezioni appendibili



ØD mm	📦	€	📄
16	1	9,80	080329012
19	1	16,50	080329016

8025

grilli per sollevamento diritti, tipo largo
acciaio al carbonio
zincati

CE

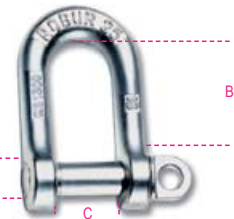

GRADO 4

DATI TECNICI

- coefficiente di sicurezza: 5
- trattamento termico: normalizzazione
- codice lotto di fabbricazione

ANALISI DI LABORATORIO

- analisi chimica
- analisi metallografica
- test di trazione

CERTIFICATI DISPONIBILI

- Specifica Prodotto
- Rapporto di Prova tipo 2.2 UNI EN10204
- Certificato di Controllo tipo 3.1 UNI EN10204
- Dichiarazione di Conformità CE

Ø mm	≈	B x C mm	WLL kg	€	📦	📄
5	3/16	21x10	70	1,15	250	080250005
6	1/4	25x12	100	1,55	250	080250006
8	5/16	33x16	250	2,60	150	080250008
10	3/8	42x20	400	2,90	180	080250010
11	7/16	46x22	500	3,50	130	080250011
12	1/2	50x24	600	3,75	100	080250012
14	9/16	57x28	800	4,85	70	080250014
16	5/8	61x32	1000	6,40	10	080250016
18	11/16	65x36	1300	9,30	10	080250018
20	3/4	70x40	1600	10,90	10	080250020
22	7/8	74x44	2000	15,00	10	080250022
25	1"	80x48	2800	20,20	2	080250025

confezioni speciali

Ø mm	"	🔧	€	📦	🚚
5	3/16	25	28,50	1	080250705
6	1/4	25	38,50	1	080250706
8	5/16	25	65,00	1	080250708
10	3/8	15	43,50	1	080250710
11	7/16	12	42,00	1	080250711
12	1/2	12	45,00	1	080250712
14	9/16	10	48,50	1	080250714

confezioni appendibili



Ø mm	🔧	€	📦	🚚
5	4	5,80	1	080259205
6	4	7,40	1	080259206
8	2	6,15	1	080259208
10	2	6,60	1	080259210
11	1	4,40	1	080259011
12	1	4,70	1	080259012
14	1	5,80	1	080259014
16	1	7,30	1	080259016
18	1	10,90	1	080259018
20	1	12,20	1	080259020
22	1	16,00	1	080259022
25	1	21,00	1	080259025

8026A

grilli per sollevamento diritti, tipo UNI
acciaio al carbonio
zincati

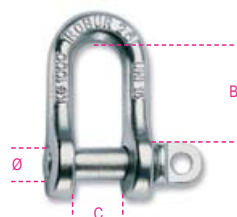

GRADO 4

DATI TECNICI

- coefficiente di sicurezza: 5
- trattamento termico: normalizzazione
- codice lotto di fabbricazione
- ANALISI DI LABORATORIO
- analisi chimica
- analisi metallografica
- test di trazione
- CERTIFICATI DISPONIBILI
- Specifica Prodotto
- Rapporto di Prova tipo 2.2 UNI EN10204
- Certificato di Controllo tipo 3.1 UNI EN10204
- Dichiarazione di Conformità CE

Ø mm	"	B x C mm	WLL kg	€	🔧	🚚
12	1/2	42x20	630	3,60	35	080260012
14	9/16	46x22	800	4,55	30	080260014
16	5/8	50x24	1000	5,80	20	080260016
18	11/16	54x26	1300	8,20	15	080260018
20	3/4	58x28	1600	10,30	10	080260020
22	7/8	69x32	2000	13,50	10	080260022
25	1"	79x36	2500	19,20	5	080260025
28	1.1/8	90x40	3150	26,50	2	080260028
32	1.1/4	100x45	4000	36,00	1	080260032
36	1.3/8	110x50	5000	52,00	1	080260036
40	1.9/16	120x55	6300	72,00	1	080260040
42	1.5/8	131x60	8000	98,50	1	080260042
45	1.3/4	143x65	10000	134,00	1	080260045
50	2"	155x70	12500	166,00	1	080260050

confezioni appendibili



Ø mm	🔧	€	📦	🚚
12	1	4,65	1	080269012
14	1	5,60	1	080269014
16	1	6,50	1	080269016
18	1	9,80	1	080269018
20	1	11,80	1	080269020
22	1	15,00	1	080269022
25	1	21,00	1	080269025



8028

grilli per sollevamento a lira
acciaio al carbonio
zincati

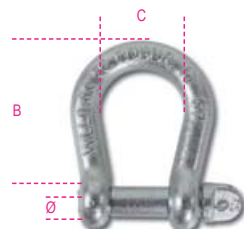

GRADO 4

DATI TECNICI

- coefficiente di sicurezza: 5
- trattamento termico: normalizzazione
- codice lotto di fabbricazione
- ANALISI DI LABORATORIO
- analisi chimica
- analisi metallografica
- test di trazione
- CERTIFICATI DISPONIBILI
- Specifica Prodotto
- Rapporto di Prova tipo 2.2 UNI EN10204
- Certificato di Controllo tipo 3.1 UNI EN10204
- Dichiarazione di Conformità CE

Ø mm	"	B x C mm	WLL kg	€	🔧	🚚
5	3/16	20x16	80	0,98	100	080280105
6	1/4	24x20	100	1,48	70	080280106
8	5/16	32x24	200	2,55	35	080280108
10	3/8	40x33	300	2,95	25	080280110
12	1/2	48x39	500	4,65	15	080280112
14	9/16	56x46	600	6,60	7	080280114
16	5/8	64x46	800	9,90	10	080280116
18	11/16	71x59	950	12,20	5	080280118
20	3/4	80x65	1100	17,50	5	080280120
22	7/8	88x72	1500	22,50	5	080280122
25	1"	100x81	2000	34,00	2	080280125
28	1.1/8	112x91	2600	52,50	1	080280128
32	1.1/4	128x104	3200	72,50	1	080280132
38	1.1/2	152x124	4500	143,50	1	080280138

confezioni appendibili



Ø mm	🔧	€	📦	🚚
5	4	4,85	1	080289305
6	4	7,10	1	080289306
8	2	6,35	1	080289308
10	2	6,90	1	080289310
12	1	5,70	1	080289112
14	1	7,60	1	080289114
16	1	10,80	1	080289116
18	1	13,80	1	080289118
20	1	19,00	1	080289120
22	1	24,00	1	080289122

8049 WLL (t)

	A°	M8	M10	M12	M16	M20	M24	M30
	0°	0,3	0,6	1	1,6	2,5	4	6,3
	0°	0,6	1,2	2	3,2	5	8	12,6
	90°	0,3	0,6	1	1,6	2,5	4	6,3
	90°	0,6	1,2	2	3,2	5	8	12,6
	0° 45°	0,4	0,8	1,4	2,2	3,5	5,6	8,8
	46° 60°	0,3	0,6	1	1,6	2,5	4	6,3
	0° 45°	0,6	1,3	2,1	3,4	5,3	8,4	13,2
	46° 60°	0,3	0,6	1	1,6	2,3	4	6,3

8049

golfari maschio per sollevamento,
orientabili a doppia articolazione,
acciaio legato ad alta resistenza

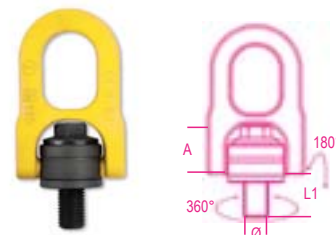

DATI TECNICI

- coefficiente di sicurezza: 5
- trattamento termico: bonifica
- codice lotto fabbricazione
- ANALISI DI LABORATORIO
- analisi chimica
- analisi metallografica
- test di trazione
- test di fatica (20.000 cicli)
- CERTIFICATI DISPONIBILI
- Specifica Prodotto
- Rapporto di Prova tipo 2.2 UNI EN10204
- Certificato di Controllo tipo 3.1 UNI EN10204
- Dichiarazione di Conformità CE

Ø mm	A mm	L1 mm	WLL kg	€	🔧	🚚
M8	31,5	14	300	99,00	1	080490008
M10	31,5	17	600	103,00	1	080490010
M12	31,5	21	1000	106,00	1	080490012
M16	45	27	1600	122,00	1	080490016
M20	45	30	2500	125,00	1	080490020
M24	60,5	36	4000	214,00	1	080490024
M30	60,5	45	6300	223,00	1	080490030



8049A WLL (t)

	β (°)	M8	M10	M12	M16	M20	M24	M30
	0	600	900	1000	2000	4000	6300	10600
	0	1200	1800	2000	4000	8000	12600	21200
	90	300	450	500	1120	2000	3150	5300
	90	600	900	1000	2240	4000	6300	10600
	0-45	400	600	700	1400	2800	4250	7100
	45-60	300	400	500	1000	2000	3150	5300
	0-45	600	900	1000	2100	4200	6300	11200
	45-60	400	600	750	1500	3000	4750	8000

8049A

golfari maschio di sollevamento a doppia articolazione, girevole sotto carico con anello saldato in acciaio legato ad alta resistenza

CE



DATI TECNICI

- coefficiente di sicurezza: 4
 - trattamento termico: bonifica
 - codice lotto fabbricazione
- ANALISI DI LABORATORIO
- analisi chimica
 - analisi metallografica
 - test di trazione
 - test di fatica (20.000 cicli)
 - carico di collaudo (100% del lotto)
- CERTIFICATI DISPONIBILI
- Specifica Prodotto
 - Rapporto di Prova tipo 2.2 UNI EN10204
 - Certificato di Controllo tipo 3.1 UNI EN10204
 - Dichiarazione di Conformità CE

\emptyset mm	E mm	A mm	WLL kg	€		
M8	13	30	300	45,00	1	080490108
M10	19	30	450	48,00	1	080490110
M12	19	30	500	51,00	1	080490112
M16	20	30	1120	55,00	1	080490116
M20	30	40	2000	72,00	1	080490120
M24	30	40	3150	104,00	1	080490124
M30	35	50	5300	168,00	1	080490130



8041

golfari maschio per sollevamento, acciaio legato ad alta resistenza grado 8

CE



DATI TECNICI

- coefficiente di sicurezza: 4
 - trattamento termico: bonifica
 - codice lotto fabbricazione
- ANALISI DI LABORATORIO
- analisi chimica
 - analisi metallografica
 - test di trazione
 - test di fatica (20.000 cicli)
 - carico di collaudo (100% del lotto)
- CERTIFICATI DISPONIBILI
- Specifica Prodotto
 - Rapporto di Prova tipo 2.2 UNI EN10204
 - Certificato di Controllo tipo 3.1 UNI EN10204
 - Dichiarazione di Conformità CE

\emptyset mm	$\frac{E}{A}$ mm	E mm	WLL kg	€		
* M8	1,25	13	800	2,70	10	080410208
* M10	1,5	17	1000	4,10	6	080410210
* M12	1,75	20,5	1600	6,20	4	080410212
* M16	2	27	3200	10,30	2	080410216
* M20	2,5	30	4800	15,50	2	080410220
* M24	3	36	6500	29,50	2	080410224
* M30	3,5	45	12000	53,50	1	080410230

(*) Caratteristiche meccaniche e materiali EN1677-1

confezioni appendibili

\emptyset mm		€		
* M8	1	4,30	1	080419208
* M10	1	6,00	1	080419210
* M12	1	8,30	1	080419212

8043

golfari femmina per sollevamento, acciaio legato ad alta resistenza grado 8

CE

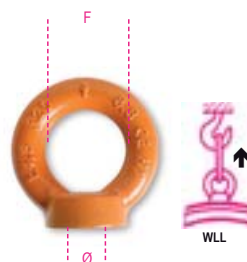

DATI TECNICI

- coefficiente di sicurezza: 4
 - trattamento termico: bonifica
 - codice lotto fabbricazione
- ANALISI DI LABORATORIO
- analisi chimica
 - analisi metallografica
 - test di trazione
 - test di fatica (20.000 cicli)
 - carico di collaudo (100% del lotto)
- CERTIFICATI DISPONIBILI
- Specifica Prodotto
 - Rapporto di Prova tipo 2.2 UNI EN10204
 - Certificato di Controllo tipo 3.1 UNI EN10204
 - Dichiarazione di Conformità CE

* M8	1,25	20	800	€		
				2,60	10	080430208
* M10	1,50	25	1000	4,00	6	080430210
* M12	1,75	30	1600	6,10	4	080430212
* M16	2	35	3200	10,00	2	080430216
* M20	2,5	40	4800	14,60	2	080430220
* M24	3	50	6500	28,50	2	080430224
* M30	3,5	60	12000	51,00	1	080430230

(*) Caratteristiche meccaniche e materiali EN1677-1

confezioni appendibili

\emptyset mm		€		
* M8	1	4,00	1	080439208
* M10	1	5,80	1	080439210
* M12	1	7,90	1	080439212



8040EZ

golfari per sollevamento
maschio, zincati

CE



DIN 580:2010-09

DATI TECNICI

- coefficiente di sicurezza: 6
- trattamento termico: normalizzazione
- codice lotto di fabbricazione

ANALISI DI LABORATORIO

- analisi chimica
- analisi metallografica
- test di trazione

CERTIFICATI DISPONIBILI

- Specifica Prodotto
- Rapporto di Prova tipo 2.2 UNI EN10204
- Certificato di Controllo tipo 3.1 UNI EN10204
- Dichiarazione di Conformità CE

Ø mm	WLL mm	E mm	WLL kg	€	📦	📄
* M6	1	11	90	1,45	60	080400406
M8	1,25	13	140	1,45	60	080400408
M10	1,5	17	230	1,95	40	080400410
M12	1,75	20,5	340	2,60	20	080400412
* M14	2	20,5	480	3,40	20	080400414
M16	2	27	700	4,30	10	080400416
* M18	2,5	27	930	5,20	10	080400418
M20	2,5	30	1200	6,60	10	080400420
* M22	2,5	30	1450	8,60	10	080400422
M24	3	36	1800	12,50	5	080400424
* M27	3	41	2400	15,50	5	080400427
M30	3,5	45	3200	26,00	2	080400430
* M33	3,5	54	3900	36,00	2	080400433
* M33F	2	54	3900	36,00	2	080400434
M36	4	54	4600	37,50	2	080400436
* M36F	3	54	4600	37,50	2	080400437
M42	4,5	63	6300	69,00	1	080400442
* M42F	3	63	6300	69,00	1	080400443
M48	5	68	8600	111,00	1	080400448
* M48F	3	68	8600	111,00	1	080400449
M56	5,5	78	11500	180,00	1	080400456
* M56F	4	78	11500	180,00	1	080400457
M64	6	90	16000	264,00	1	080400464
* M64F	4	90	16000	264,00	1	080400465

*Misure dimensionate secondo Fascicolo Tecnico Robur

confezioni appendibili



Ø mm	WLL mm	€	📦	📄
M6	4	7,20	1	080409606
M8	4	7,20	1	080409608
M10	2	5,40	1	080409610
M12	1	3,70	1	080409412
* M14	1	4,40	1	080409414
M16	1	5,40	1	080409416
* M18	1	6,30	1	080409418
M20	1	7,60	1	080409420
* M22	1	10,00	1	080409422
M24	1	13,60	1	080409424
* M27	1	17,00	1	080409427
M30	1	27,00	1	080409430

8040EN

golfari per sollevamento
maschio, neri

CE



DIN 580:2010-09

DATI TECNICI

- coefficiente di sicurezza: 6
- trattamento termico: normalizzazione
- codice lotto di fabbricazione

ANALISI DI LABORATORIO

- analisi chimica
- analisi metallografica
- test di trazione

CERTIFICATI DISPONIBILI

- Specifica Prodotto
- Rapporto di Prova tipo 2.2 UNI EN10204
- Certificato di Controllo tipo 3.1 UNI EN10204
- Dichiarazione di Conformità CE

Ø mm	WLL mm	E mm	WLL kg	€	📦	📄
* M6	1	11	90	1,40	60	080400306
M8	1,25	13	140	1,40	60	080400308
M10	1,5	17	230	1,90	40	080400310
M12	1,75	20,5	340	2,60	20	080400312
* M14	2	20,5	480	3,25	20	080400314
M16	2	27	700	4,00	10	080400316
* M18	2,5	27	930	5,00	10	080400318
M20	2,5	30	1200	6,20	10	080400320
* M22	2,5	30	1450	8,20	10	080400322
M24	3	36	1800	11,50	5	080400324
* M27	3	41	2400	14,50	5	080400327
M30	3,5	45	3200	24,00	2	080400330
* M33	3,5	54	3900	34,00	2	080400333
* M33F	2	54	3900	34,00	2	080400334
M36	4	54	4600	35,50	2	080400336
* M36F	3	54	4600	35,50	2	080400337
M42	4,5	63	6300	66,00	1	080400342
* M42F	3	63	6300	66,00	1	080400343
M48	5	68	8600	108,00	1	080400348
* M48F	3	68	8600	108,00	1	080400349
M56	5,5	78	11500	172,00	1	080400356
* M56F	4	78	11500	172,00	1	080400357
M64	6	90	16000	250,00	1	080400364
* M64F	4	90	16000	250,00	1	080400365

*Misure dimensionate secondo Fascicolo Tecnico Robur

confezioni appendibili



Ø mm	WLL mm	€	📦	📄
M6	4	6,80	1	080409506
M8	4	6,80	1	080409508
M10	2	4,90	1	080409510
M12	1	3,50	1	080409312
* M14	1	4,20	1	080409314
M16	1	4,90	1	080409316
* M18	1	5,90	1	080409318
M20	1	6,90	1	080409320
* M22	1	9,40	1	080409322
M24	1	12,50	1	080409324
* M27	1	15,50	1	080409327
M30	1	25,00	1	080409330

8042EN

golfari per sollevamento
femmina, neri

CE



DIN 582:2010-09

DATI TECNICI

- coefficiente di sicurezza: 6
- trattamento termico: normalizzazione
- codice lotto di fabbricazione

ANALISI DI LABORATORIO

- analisi chimica
- analisi metallografica
- test di trazione

CERTIFICATI DISPONIBILI

- Specifica Prodotto
- Rapporto di Prova tipo 2.2 UNI EN10204
- Certificato di Controllo tipo 3.1 UNI EN10204
- Dichiarazione di Conformità CE

Ø mm	WLL mm	F mm	WLL kg	€	📦	📄
* M6	1	14	90	1,40	60	080420306
M8	1,25	20	140	1,40	60	080420308
M10	1,5	25	230	1,85	40	080420310
M12	1,75	30	340	2,60	30	080420312
* M14	2	30	480	3,30	30	080420314
M16	2	35	700	3,90	20	080420316
* M18	2,5	35	930	4,90	20	080420318
M20	2,5	40	1200	6,00	10	080420320
* M22	2,5	40	1450	8,00	10	080420322
M24	3	50	1800	11,50	5	080420324
* M27	3	55	2400	14,00	5	080420327
M30	3,5	60	3200	22,50	3	080420330
M36	4	70	4600	34,00	2	080420336
* M36F	3	70	4600	34,00	2	080420337
M42	4,5	80	6300	63,00	1	080420342
* M42F	3	80	6300	63,00	1	080420343
M48	5	90	8600	103,00	1	080420348
* M48F	3	90	8600	103,00	1	080420349

*Misure dimensionate secondo Fascicolo Tecnico Robur

confezioni appendibili



Ø mm	WLL mm	€	📦	📄
M6	4	6,80	1	080429506
M8	4	6,80	1	080429508
M10	2	4,90	1	080429510
M12	1	3,40	1	080429312
* M14	1	4,00	1	080429314
M16	1	4,90	1	080429316
* M18	1	5,80	1	080429318
M20	1	7,00	1	080429320
* M22	1	9,00	1	080429322
M24	1	13,00	1	080429324
* M27	1	15,50	1	080429327
M30	1	23,50	1	080429330



8042EZ

golfari per sollevamento
femmina, zincati

CE



DIN 582:2010-09

DATI TECNICI

- coefficiente di sicurezza: 6
- trattamento termico: normalizzazione
- codice lotto di fabbricazione

ANALISI DI LABORATORIO

- analisi chimica
- analisi metallografica
- test di trazione

CERTIFICATI DISPONIBILI

- Specifica Prodotto
- Rapporto di Prova tipo 2.2 UNI EN10204
- Certificato di Controllo tipo 3.1 UNI EN10204
- Dichiarazione di Conformità CE

Ø mm	F mm	WLL kg	€	Imb.	Caric.
* M6	14	90	1,45	60	080420406
M8	20	140	1,45	60	080420408
M10	25	230	1,95	40	080420410
M12	30	340	2,70	30	080420412
* M14	35	480	3,40	30	080420414
M16	40	700	4,30	20	080420416
* M18	45	930	5,20	20	080420418
M20	50	1200	6,50	10	080420420
* M22	55	1450	8,50	10	080420422
M24	60	1800	12,50	5	080420424
* M27	70	2400	15,00	5	080420427
M30	80	3200	24,00	3	080420430
M36	100	4600	37,00	2	080420436
* M36F	100	4600	37,00	2	080420437
M42	120	6300	67,00	1	080420442
* M42F	120	6300	67,00	1	080420443
M48	150	8600	109,00	1	080420448
* M48F	150	8600	109,00	1	080420449

*Misure dimensionate secondo Fascicolo Tecnico Robur

confezioni appendibili



Ø mm	F mm	WLL kg	€	Imb.	Caric.
M6	4	7,00	7,00	1	080429606
M8	4	7,00	7,00	1	080429608
M10	2	5,00	5,00	1	080429610
M12	1	3,70	3,70	1	080429412
* M14	1	4,20	4,20	1	080429414
M16	1	5,20	5,20	1	080429416
* M18	1	6,00	6,00	1	080429418
M20	1	7,40	7,40	1	080429420
* M22	1	9,40	9,40	1	080429422
M24	1	14,50	14,50	1	080429424
* M27	1	16,00	16,00	1	080429427
M30	1	24,50	24,50	1	080429430

8044

golfari per sollevamento
femmina, neri

CE



UNI 2948

DATI TECNICI

- coefficiente di sicurezza: 4
- trattamento termico: normalizzazione
- codice lotto di fabbricazione

ANALISI DI LABORATORIO

- analisi chimica
- analisi metallografica
- test di trazione

CERTIFICATI DISPONIBILI

- Specifica Prodotto
- Rapporto di Prova tipo 2.2 UNI EN10204
- Certificato di Controllo tipo 3.1 UNI EN10204
- Dichiarazione di Conformità CE

Ø mm	F mm	WLL kg	€	Imb.	Caric.
M8	1,25	80	1,85	4	080440008
M10	1,5	160	3,05	4	080440010
M12	1,75	250	5,30	4	080440012
M14	2	250	8,60	2	080440014
M16	2	400	8,70	2	080440016
M20	2,5	630	14,50	2	080440020
M24	3	1000	25,00	2	080440024



PENDENTI DI CATENA Grado 8

WLL Ton		UNI EN 818	
Ø D mm	WLL 1	WLL 2	
		0° < β ≤ 45°	45° < β ≤ 60°
6	1,12	1,6	1,12
7	1,5	2,12	1,5
8	2	2,8	2
10	3,15	4,25	3,15
13	5,3	7,5	5,3
16	8	11,2	8

Ø D mm	WLL 3	WLL 4	
		0° < β ≤ 45°	45° < β ≤ 60°
6	2,36	1,7	1,7
7	3,15	2,24	2,24
8	4,25	3	3
10	6,7	4,75	4,75
13	11,2	8	8
16	17	11,2	11,2

8091

pendenti per sollevamento
catena a 1 braccio
grado 8

CE

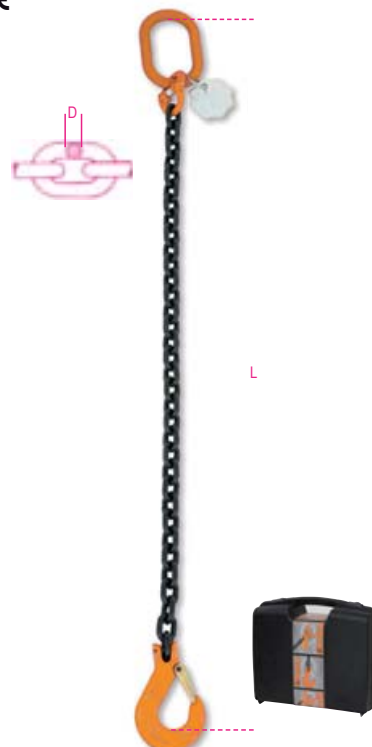

UNI EN 818-4

DATI TECNICI

- coefficiente di sicurezza: 4
- piastrina di identificazione seriale
- CERTIFICATI ALLEGATI
- Certificato del Fabbricante UNI EN818-4
- Dichiarazione di Conformità CE
- CERTIFICATI DISPONIBILI
- Specifica Prodotto

D mm	L m	WLL ton	€	Imb.	Caric.
6*	1	1,12	74,00	1	080910001
6*	2	1,12	90,00	1	080910002
6*	3	1,12	106,00	1	080910003
6*	4	1,12	122,00	1	080910004
7*	1	1,5	80,50	1	080910021
7*	2	1,5	101,00	1	080910022
7*	3	1,5	121,50	1	080910023
7*	4	1,5	142,00	1	080910024
8*	1	2	89,50	1	080910041
8*	2	2	113,50	1	080910042
8*	3	2	137,50	1	080910043
8*	4	2	172,50	1	080910044
10*	1	3,15	114,00	1	080910051
10*	2	3,15	150,00	1	080910052
10*	3	3,15	197,00	1	080910053
10*	4	3,15	233,00	1	080910054
13*	1	5,3	183,00	1	080910131
13*	2	5,3	245,00	1	080910132
13*	3	5,3	305,00	1	080910133
13*	4	5,3	367,00	1	080910134
16*	1	8	356,00	1	080910161
16*	2	8	448,00	1	080910162
16*	3	8	542,00	1	080910163
16*	4	8	636,00	1	080910164

* Imballo in valigetta

8091SL

pendenti per sollevamento
catena a 1 braccio, gancio Self-Locking
grado 8

CE



UNI EN 818-4

DATI TECNICI

- coefficiente di sicurezza: 4
 - piastrina di identificazione seriale
- CERTIFICATI ALLEGATI**
- Certificato del Fabbricante UNI EN818-4
 - Dichiarazione di Conformità CE
- CERTIFICATI DISPONIBILI**
- Specifica Prodotto

D mm	L m	WLL ton	€		
6*	1	1,12	93,00	1	080910201
6*	2	1,12	109,00	1	080910202
6*	3	1,12	125,00	1	080910203
6*	4	1,12	141,00	1	080910204
7*	1	1,5	105,50	1	080910221
7*	2	1,5	126,00	1	080910222
7*	3	1,5	146,50	1	080910223
7*	4	1,5	167,00	1	080910224
8*	1	2	114,50	1	080910241
8*	2	2	133,50	1	080910242
8*	3	2	162,50	1	080910243
8*	4	2	197,50	1	080910244
10*	1	3,15	143,00	1	080910251
10*	2	3,15	179,00	1	080910252
10*	3	3,15	226,00	1	080910253
10*	4	3,15	273,00	1	080910254
13*	1	5,3	250,00	1	080910331
13*	2	5,3	331,00	1	080910332
13*	3	5,3	374,00	1	080910333
13*	4	5,3	453,00	1	080910334
16*	1	8	469,00	1	080910361
16*	2	8	589,00	1	080910362
16*	3	8	655,00	1	080910363
16*	4	8	777,00	1	080910364

* Imballo in valigetta

8092

pendenti per sollevamento
catena a 2 bracci
grado 8

CE



UNI EN 818-4

DATI TECNICI

- coefficiente di sicurezza: 4
 - piastrina di identificazione seriale
- CERTIFICATI ALLEGATI**
- Certificato del Fabbricante UNI EN818-4
 - Dichiarazione di Conformità CE
- CERTIFICATI DISPONIBILI**
- Specifica Prodotto

D mm	L m	WLL ton	€		
6*	1	1,6	107,50	1	080920001
6*	2	1,6	139,50	1	080920002
6*	3	1,6	171,50	1	080920003
6*	4	1,6	214,50	1	080920004
7*	1	2,12	124,50	1	080920021
7*	2	2,12	165,50	1	080920022
7*	3	2,12	217,50	1	080920023
7*	4	2,12	258,00	1	080920024
8*	1	2,8	140,00	1	080920041
8*	2	2,8	188,00	1	080920042
8*	3	2,8	247,00	1	080920043
8*	4	2,8	295,00	1	080920044
10*	1	4,25	203,50	1	080920051
10*	2	4,25	275,00	1	080920052
10*	3	4,25	345,00	1	080920053
10*	4	4,25	417,00	1	080920054
13*	1	7,5	323,00	1	080920131
13*	2	7,5	445,00	1	080920132
13	3	7,5	551,00	1	080920133
13	4	7,5	720,00	1	080920134
16*	1	11,2	644,00	1	080920161
16	2	11,2	859,00	1	080920162
16	3	11,2	1.047,00	1	080920163
16	4	11,2	1.235,00	1	080920164

* Imballo in valigetta

8092SL

pendenti per sollevamento
catena a 2 bracci, ganci Self-Locking
grado 8

CE



UNI EN 818-4

DATI TECNICI

- coefficiente di sicurezza: 4
 - piastrina di identificazione seriale
- CERTIFICATI ALLEGATI**
- Certificato del Fabbricante UNI EN818-4
 - Dichiarazione di Conformità CE
- CERTIFICATI DISPONIBILI**
- Specifica Prodotto

D mm	L m	WLL ton	€		
6*	1	1,6	146,00	1	080920201
6*	2	1,6	171,50	1	080920202
6*	3	1,6	203,50	1	080920203
6*	4	1,6	253,00	1	080920204
7*	1	2,12	173,50	1	080920221
7*	2	2,12	206,50	1	080920222
7*	3	2,12	267,00	1	080920223
7*	4	2,12	308,00	1	080920224
8*	1	2,8	180,00	1	080920241
8*	2	2,8	239,00	1	080920242
8*	3	2,8	287,00	1	080920243
8*	4	2,8	345,00	1	080920244
10*	1	4,25	283,00	1	080920251
10*	2	4,25	333,00	1	080920252
10*	3	4,25	403,00	1	080920253
10*	4	4,25	497,00	1	080920254
13*	1	7,5	495,00	1	080920331
13*	2	7,5	620,00	1	080920332
13*	3	7,5	723,00	1	080920333
13*	4	7,5	892,00	1	080920334
16*	1	11,2	926,00	1	080920361
16*	2	11,2	1.141,00	1	080920362
16*	3	11,2	1.330,00	1	080920363
16*	4	11,2	1.515,00	1	080920364

* Imballo in valigetta



8094

pendenti per sollevamento
catena a 4 bracci
grado 8

CE



UNI EN 818-4

DATI TECNICI

- coefficiente di sicurezza: 4
 - piastrina di identificazione seriale
- CERTIFICATI ALLEGATI**
- Certificato del Fabbricante UNI EN818-4
 - Dichiarazione di Conformità CE
- CERTIFICATI DISPONIBILI**
- Specifica Prodotto

D mm	L m	WLL ton	€		
6*	1	2,36	221,00	1	080940001
6*	2	2,36	296,00	1	080940002
6*	3	2,36	360,00	1	080940003
6*	4	2,36	422,00	1	080940004
7*	1	3,15	259,00	1	080940021
7*	2	3,15	341,00	1	080940022
7*	3	3,15	421,00	1	080940023
7*	4	3,15	503,00	1	080940024
8*	1	4,25	310,00	1	080940041
8*	2	4,25	404,00	1	080940042
8*	3	4,25	500,00	1	080940043
8	4	4,25	623,00	1	080940044
10*	1	6,7	411,00	1	080940051
10	2	6,7	567,00	1	080940052
10	3	6,7	726,00	1	080940053
10	4	6,7	870,00	1	080940054
13	1	11,2	685,00	1	080940131
13	2	11,2	933,00	1	080940132
13	3	11,2	1.181,00	1	080940133
13	4	11,2	1.430,00	1	080940134
16	1	17	1.335,00	1	080940161
16	2	17	1.715,00	1	080940162
16	3	17	2.090,00	1	080940163
16	4	17	2.465,00	1	080940164

* Imballo in valigetta

8094SL

pendenti per sollevamento
catena a 4 bracci, ganci Self-Locking
grado 8

CE



UNI EN 818-4

DATI TECNICI

- coefficiente di sicurezza: 4
 - piastrina di identificazione seriale
- CERTIFICATI ALLEGATI**
- Certificato del Fabbricante UNI EN818-4
 - Dichiarazione di Conformità CE
- CERTIFICATI DISPONIBILI**
- Specifica Prodotto

D mm	L m	WLL ton	€		
6*	1	2,36	298,00	1	080940201
6*	2	2,36	373,00	1	080940202
6*	3	2,36	437,00	1	080940203
6*	4	2,36	499,00	1	080940204
7*	1	3,15	357,00	1	080940221
7*	2	3,15	439,00	1	080940222
7*	3	3,15	519,00	1	080940223
7*	4	3,15	601,00	1	080940224
8*	1	4,25	390,00	1	080940241
8*	2	4,25	484,00	1	080940242
8*	3	4,25	600,00	1	080940243
8	4	4,25	723,00	1	080940244
10*	1	6,7	534,00	1	080940251
10	2	6,7	683,00	1	080940252
10	3	6,7	849,00	1	080940253
10	4	6,7	993,00	1	080940254
13	1	11,2	967,00	1	080940331
13	2	11,2	1.215,00	1	080940332
13	3	11,2	1.465,00	1	080940333
13	4	11,2	1.710,00	1	080940334
16	1	17	1.810,00	1	080940361
16	2	17	2.185,00	1	080940362
16	3	17	2.560,00	1	080940363
16	4	17	2.940,00	1	080940364

* Imballo in valigetta



8096

pendenti per sollevamento
con ganci accorciatori
catena ad 1 braccio, grado 8

CE



UNI EN 818-4

DATI TECNICI

- coefficiente di sicurezza: 4
 - piastrina di identificazione seriale
- CERTIFICATI ALLEGATI**
- Certificato del Fabbricante UNI EN818-4
 - Dichiarazione di Conformità CE
- CERTIFICATI DISPONIBILI**
- Specifica Prodotto

D mm	L m	WLL ton	€		
6*	1	1,12	87,00	1	080960001
6*	2	1,12	103,00	1	080960002
6*	3	1,12	119,00	1	080960003
6*	4	1,12	132,00	1	080960004
7*	1	1,5	96,50	1	080960021
7*	2	1,5	117,00	1	080960022
7*	3	1,5	133,00	1	080960023
7*	4	1,5	153,50	1	080960024
8*	1	2	106,00	1	080960041
8*	2	2	130,00	1	080960042
8*	3	2	154,00	1	080960043
8*	4	2	189,00	1	080960044
10*	1	3,15	146,00	1	080960051
10*	2	3,15	193,00	1	080960052
10*	3	3,15	229,00	1	080960053
10*	4	3,15	265,00	1	080960054
13*	1	5,3	238,50	1	080960131
13*	2	5,3	282,00	1	080960132
13*	3	5,3	342,00	1	080960133
13*	4	5,3	422,00	1	080960134
16*	1	8	467,00	1	080960161
16*	2	8	531,00	1	080960162
16*	3	8	625,00	1	080960163
16	4	8	746,00	1	080960164

* Imballo in valigetta

Robur

8096SL

pendenti per sollevamento
con gancio Self-Locking e accorciatore
catena ad 1 braccio, grado 8

CE



UNI EN 818-4

DATI TECNICI

- coefficiente di sicurezza: 4
- piastrina di identificazione seriale
- CERTIFICATI ALLEGATI
- Certificato del Fabbricante UNI EN818-4
- Dichiarazione di Conformità CE
- CERTIFICATI DISPONIBILI
- Specifica Prodotto

D mm	L m	WLL ton	€	Imb.	Imb.
6*	1	1,12	103,00	1	080960201
6*	2	1,12	119,00	1	080960202
6*	3	1,12	135,00	1	080960203
6*	4	1,12	151,00	1	080960204
7*	1	1,5	117,00	1	080960221
7*	2	1,5	137,50	1	080960222
7*	3	1,5	158,00	1	080960223
7*	4	1,5	178,50	1	080960224
8*	1	2	126,00	1	080960241
8*	2	2	150,00	1	080960242
8*	3	2	174,00	1	080960243
8*	4	2	209,00	1	080960244
10*	1	3,15	175,00	1	080960251
10*	2	3,15	222,00	1	080960252
10*	3	3,15	258,00	1	080960253
10*	4	3,15	294,00	1	080960254
13*	1	5,3	306,00	1	080960331
13*	2	5,3	368,00	1	080960332
13*	3	5,3	428,00	1	080960333
13*	4	5,3	490,00	1	080960334
16*	1	8	580,00	1	080960361
16*	2	8	672,00	1	080960362
16*	3	8	766,00	1	080960363
16	4	8	859,00	1	080960364

* Imballo in valigetta

8097

pendenti per sollevamento
con ganci accorciatori
catena a 2 bracci, grado 8

CE



UNI EN 818-4

DATI TECNICI

- coefficiente di sicurezza: 4
- piastrina di identificazione seriale
- CERTIFICATI ALLEGATI
- Certificato del Fabbricante UNI EN818-4
- Dichiarazione di Conformità CE
- CERTIFICATI DISPONIBILI
- Specifica Prodotto

D mm	L m	WLL ton	€	Imb.	Imb.
6*	1	1,6	134,00	1	080970001
6*	2	1,6	159,50	1	080970002
6*	3	1,6	198,00	1	080970003
6*	4	1,6	234,50	1	080970004
7*	1	2,12	155,50	1	080970021
7*	2	2,12	199,50	1	080970022
7*	3	2,12	240,50	1	080970023
7*	4	2,12	281,00	1	080970024
8*	1	2,8	173,00	1	080970041
8*	2	2,8	222,00	1	080970042
8*	3	2,8	280,00	1	080970043
8*	4	2,8	328,00	1	080970044
10*	1	4,25	267,00	1	080970051
10*	2	4,25	339,00	1	080970052
10*	3	4,25	409,00	1	080970053
10*	4	4,25	481,00	1	080970054
13*	1	7,5	432,00	1	080970131
13*	2	7,5	556,00	1	080970132
13	3	7,5	670,00	1	080970133
13	4	7,5	794,00	1	080970134
16	1	11,2	837,00	1	080970161
16	2	11,2	1.025,00	1	080970162
16	3	11,2	1.210,00	1	080970163
16	4	11,2	1.400,00	1	080970164

* Imballo in valigetta

Robur

Robur

8097SL

pendenti per sollevamento
con ganci Self-Locking e accorciatori
catena a 2 bracci, grado 8

CE



UNI EN 818-4

DATI TECNICI

- coefficiente di sicurezza: 4
- piastrina di identificazione seriale
- CERTIFICATI ALLEGATI
- Certificato del Fabbricante UNI EN818-4
- Dichiarazione di Conformità CE
- CERTIFICATI DISPONIBILI
- Specifica Prodotto

D mm	L m	WLL ton	€	Imb.	Imb.
6*	1	1,6	166,00	1	080970201
6*	2	1,6	191,50	1	080970202
6*	3	1,6	230,00	1	080970203
6*	4	1,6	273,00	1	080970204
7*	1	2,12	196,50	1	080970221
7*	2	2,12	240,50	1	080970222
7*	3	2,12	281,00	1	080970223
7*	4	2,12	322,00	1	080970224
8*	1	2,8	213,00	1	080970241
8*	2	2,8	262,00	1	080970242
8*	3	2,8	320,00	1	080970243
8*	4	2,8	368,00	1	080970244
10*	1	4,25	325,00	1	080970251
10*	2	4,25	397,00	1	080970252
10*	3	4,25	467,00	1	080970253
10*	4	4,25	539,00	1	080970254
13*	1	7,5	567,00	1	080970331
13*	2	7,5	691,00	1	080970332
13	3	7,5	842,00	1	080970333
13	4	7,5	929,00	1	080970334
16	1	11,2	1.119,00	1	080970361
16	2	11,2	1.305,00	1	080970362
16	3	11,2	1.495,00	1	080970363
16	4	11,2	1.625,00	1	080970364

* Imballo in valigetta

8098

pendenti per sollevamento
con ganci accorciatori
catena a 4 bracci, grado 8

CE



UNI EN 818-4

DATI TECNICI

- coefficiente di sicurezza: 4
 - piastrina di identificazione seriale
- CERTIFICATI ALLEGATI**
- Certificato del Fabbricante UNI EN818-4
 - Dichiarazione di Conformità CE
- CERTIFICATI DISPONIBILI**
- Specifica Prodotto

D mm	L m	WLL ton	€		
6*	1	2,36	274,00	1	080980001
6*	2	2,36	336,00	1	080980002
6*	3	2,36	398,00	1	080980003
6*	4	2,36	462,00	1	080980004
7*	1	3,15	321,00	1	080980021
7*	2	3,15	387,00	1	080980022
7*	3	3,15	467,00	1	080980023
7*	4	3,15	549,00	1	080980024
8*	1	4,25	356,00	1	080980041
8*	2	4,25	450,00	1	080980042
8*	3	4,25	546,00	1	080980043
8	4	4,25	669,00	1	080980044
10*	1	6,7	495,00	1	080980051
10	2	6,7	666,00	1	080980052
10	3	6,7	810,00	1	080980053
10	4	6,7	954,00	1	080980054
13	1	11,2	833,00	1	080980131
13	2	11,2	1.081,00	1	080980132
13	3	11,2	1.340,00	1	080980133
13	4	11,2	1.575,00	1	080980134
16	1	17	1.670,00	1	080980161
16	2	17	2.045,00	1	080980162
16	3	17	2.420,00	1	080980163
16	4	17	2.800,00	1	080980164

* Imballo in valigetta

8098SL

pendenti per sollevamento
con ganci Self-Locking e accorciatori
catena a 4 bracci, grado 8

CE



UNI EN 818-4

DATI TECNICI

- coefficiente di sicurezza: 4
 - piastrina di identificazione seriale
- CERTIFICATI ALLEGATI**
- Certificato del Fabbricante UNI EN818-4
 - Dichiarazione di Conformità CE
- CERTIFICATI DISPONIBILI**
- Specifica Prodotto

D mm	L m	WLL ton	€		
6*	1	2,36	338,00	1	080980201
6*	2	2,36	413,00	1	080980202
6*	3	2,36	462,00	1	080980203
6*	4	2,36	539,00	1	080980204
7*	1	3,15	403,00	1	080980221
7*	2	3,15	469,00	1	080980222
7*	3	3,15	549,00	1	080980223
7*	4	3,15	631,00	1	080980224
8*	1	4,25	456,00	1	080980241
8*	2	4,25	530,00	1	080980242
8	3	4,25	626,00	1	080980243
8*	4	4,25	749,00	1	080980244
10*	1	6,7	611,00	1	080980251
10	2	6,7	782,00	1	080980252
10	3	6,7	926,00	1	080980253
10	4	6,7	1.070,00	1	080980254
13	1	11,2	1.103,00	1	080980331
13	2	11,2	1.350,00	1	080980332
13	3	11,2	1.610,00	1	080980333
13	4	11,2	1.845,00	1	080980334
16	1	17	2.140,00	1	080980361
16	2	17	2.520,00	1	080980362
16	3	17	2.890,00	1	080980363
16	4	17	3.250,00	1	080980364

* Imballo in valigetta

8085R

campanelle per sollevamento,
acciaio legato ad alta resistenza
Il carico di lavoro WLL è relativo all'utilizzo con imbragature
ad 1 braccio.

CE



EN 1677-4
GRADO 8

DATI TECNICI

- coefficiente di sicurezza: 4
 - trattamento termico: bonifica
 - codice lotto fabbricazione
- ANALISI DI LABORATORIO**
- analisi chimica, analisi metallografica
 - test carico di prova (WLL x 2,5)
 - test di trazione
 - test di fatica (min. 20.000 cicli)
- CERTIFICATI DISPONIBILI**
- Specifica Prodotto
 - Rapporto di Prova tipo 2.2 UNI EN10204
 - Certificato di Controllo tipo 3.1 UNI EN10204
 - Dichiarazione di Conformità CE

WLL kg	Ø mm	A mm	€		
8085R	1600	7 110	8,50	1	080850215
8085R	2120	8 110	12,00	1	080850220
8085R	3150	10 135	17,00	1	080850232
8085R	5300	13 160	30,00	1	080850253

8085 8,0	8000	16 180	60,00	1	080850080
8085 11,2	11200	19 200	97,00	1	080850190

* Abbinata a catena ø 6, WLL= 1120 kg

8086

campanelle per sollevamento triple,
acciaio legato ad alta resistenza
grado 8

Il carico di lavoro WLL è relativo all'utilizzo con imbragature
a 3 o 4 bracci e angolo β inferiore a 45°

CE



EN 1677-4

DATI TECNICI

- coefficiente di sicurezza: 4
 - trattamento termico: bonifica
 - codice lotto fabbricazione
- ANALISI DI LABORATORIO**
- analisi chimica, analisi metallografica
 - test carico di prova (WLL x 2,5)
 - test di trazione
 - test di fatica (min. 20.000 cicli)
- CERTIFICATI DISPONIBILI**
- Specifica Prodotto
 - Rapporto di Prova tipo 2.2 UNI EN10204
 - Certificato di Controllo tipo 3.1 UNI EN10204
 - Dichiarazione di Conformità CE

WLL kg	Ø mm	B mm	C mm	€		
* 3150	7	135	75	55,00	1	080860021
4250	8	160	90	85,00	1	080860042
6700	10	180	100	109,00	1	080860067
11200	13	200	110	177,00	1	080860100
17000	16	260	140	258,00	1	080860117

* Abbinata a catena ø 6mm, WLL= 2360 kg

8090R

maglie di giunzione per sollevamento, acciaio legato ad alta resistenza grado 8

CE

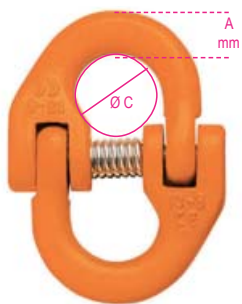

EN 1677-1

DATI TECNICI

- coefficiente di sicurezza: 4
- trattamento termico: bonifica
- codice lotto fabbricazione
- ANALISI DI LABORATORIO
- analisi chimica, analisi metallografica
- test carico di prova (WLL x 2,5)
- test di trazione
- test di fatica (min. 20.000 cicli)
- CERTIFICATI DISPONIBILI
- Specifica Prodotto
- Rapporto di Prova tipo 2.2 UNI EN10204
- Certificato di Controllo tipo 3.1 UNI EN10204
- Dichiarazione di Conformità CE

	WLL	ØC	A	€		
Ø mm	kg	max	mm			
8090R	6	1120	13	7,20	1	080900111
8090R	7	1500	18	9,30	1	080900115
8090R	8	2000	18	11,40	1	080900120
8090R	10	3150	22	14,00	1	080900131
8090R	13	5300	30	25,00	1	080900153

8090	16	8000	32	55,00	1	080900080
------	----	------	----	-------	---	-----------

8060R

ganci per sollevamento tipo Clevis a forcella, acciaio legato ad alta resistenza grado 8

CE



EN 1677-2

DATI TECNICI

- coefficiente di sicurezza: 4
- trattamento termico: bonifica
- codice lotto perno, linguetta, corpo
- ANALISI DI LABORATORIO
- analisi chimica, analisi metallografica
- test di trazione
- test di fatica (min. 20.000 cicli)
- carico di collaudo (100% del lotto)
- CERTIFICATI DISPONIBILI
- Specifica Prodotto
- Rapporto di Prova tipo 2.2 UNI EN10204
- Certificato di Controllo tipo 3.1 UNI EN10204
- Dichiarazione di Conformità CE

	WLL	C	€			
kg	Ø mm	mm				
8060R	1120	6	19	13,50	1	080600111
8060R	1500	7	19	14,50	1	080600115
8060R	2000	8	21	15,00	1	080600120
8060R	3150	10	27	26,00	1	080600132
8060R	5300	13	35	41,50	1	080600153

8060	8000	16	48	132,00	1	080600080
------	------	----	----	--------	---	-----------

8058R

ganci per sollevamento tipo self-locking a forcella acciaio legato ad alta resistenza grado 8

CE



EN 1677-3

DATI TECNICI

- coefficiente di sicurezza: 4
- trattamento termico: bonifica
- codice lotto fabbricazione
- ANALISI DI LABORATORIO
- analisi chimica, analisi metallografica
- test di trazione
- test di fatica (min. 20.000 cicli)
- carico di collaudo (100% del lotto)
- CERTIFICATI DISPONIBILI
- Specifica Prodotto
- Rapporto di Prova tipo 2.2 UNI EN10204
- Certificato di Controllo tipo 3.1 UNI EN10204
- Dichiarazione di Conformità CE

	WLL	J min	€			
kg	Ø mm	mm				
8058R	1120	6	28	29,50	1	080580112
8058R	2000	7-8	34	35,00	1	080580120
8058R	3150	10	44	55,00	1	080580132
8058R	5300	13	52	109,00	1	080580153

8058	8000	16	67	245,00	1	080580080
------	------	----	----	--------	---	-----------

8061R

ganci accorciatori a forcella con sicura di bloccaggio, acciaio legato ad alta resistenza grado 8

CE

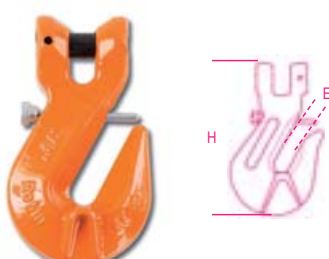

EN 1677-1

DATI TECNICI

- coefficiente di sicurezza: 4
- trattamento termico: bonifica
- codice lotto fabbricazione
- ANALISI DI LABORATORIO
- analisi chimica, analisi metallografica
- test di trazione
- test di fatica (min. 20.000 cicli)
- carico di collaudo (100% del lotto)
- CERTIFICATI DISPONIBILI
- Specifica Prodotto
- Rapporto di Prova tipo 2.2 UNI EN10204
- Certificato di Controllo tipo 3.1 UNI EN10204
- Dichiarazione di Conformità CE

	WLL	E	€			
kg	Ø mm	mm				
8061R	1120	6	8	10,00	1	080610211
8061R	2000	7-8	11	11,50	1	080610220
8061R	3150	10	13	21,00	1	080610231
8061R	5300	13	17	37,00	1	080610253

8061F	8000	16	20	83,00	1	080610180
-------	------	----	----	-------	---	-----------

8052

ganci per sollevamento ad occhio, acciaio legato ad alta resistenza grado 8

CE



EN 1677-2

DATI TECNICI

- coefficiente di sicurezza: 4
- trattamento termico: bonifica
- codice lotto fabbricazione
- ANALISI DI LABORATORIO
- analisi chimica, analisi metallografica
- test carico di prova (2,5 x wll)
- test di trazione
- test di fatica (min. 20.000 cicli)
- carico di collaudo (100% del lotto)
- CERTIFICATI DISPONIBILI
- Specifica Prodotto
- Rapporto di Prova tipo 2.2 UNI EN10204
- Certificato di Controllo tipo 3.1 UNI EN10204
- Dichiarazione di Conformità CE

	WLL	C	€		
kg	mm	mm			
8052	800	18	5,15	1	080520008
8052	1120	22,5	6,90	1	080520011
8052	2000	30	14,60	1	080520020
8052	3150	36	22,50	1	080520031
8052	4000	39,5	29,50	1	080520040

8055S	5400	32	56,50	1	080550145
8055S	8000	43	98,50	1	080550170
8055S	11500	53	196,00	1	080550215
8055S	16000	58	262,00	1	080550260
8055S	22000	78	615,00	1	080550320

8057R

ganci per sollevamento tipo self-locking ad occhio, acciaio legato ad alta resistenza grado 8

CE



EN 1677-3

DATI TECNICI

- coefficiente di sicurezza: 4
- trattamento termico: bonifica
- codice lotto fabbricazione
- ANALISI DI LABORATORIO
- analisi chimica, analisi metallografica
- test di trazione
- test di fatica (min. 20.000 cicli)
- carico di collaudo (100% del lotto)
- CERTIFICATI DISPONIBILI
- Specifica Prodotto
- Rapporto di Prova tipo 2.2 UNI EN10204
- Certificato di Controllo tipo 3.1 UNI EN10204
- Dichiarazione di Conformità CE

	WLL	J min	ØB	€		
kg	Ø mm	mm	mm			
8057R	1120	6	28	23,50	1	080570112
8057R	2000	7-8	34	28,00	1	080570120
8057R	3150	10	44	49,50	1	080570132

8057	5300	13	54	175,00	1	080570053
------	------	----	----	--------	---	-----------

8063

ganci per sollevamento orientabili (non sotto carico) acciaio legato alta resistenza grado 8

CE



EN 1677-1

DATI TECNICI

- coefficiente di sicurezza: 4
- trattamento termico: bonifica
- codice lotto fabbricazione
- ANALISI DI LABORATORIO
- analisi chimica, analisi metallografica
- test di trazione
- test di fatica (min. 20.000 cicli)
- carico di collaudo (100% del lotto)

CERTIFICATI DISPONIBILI

- Specifica Prodotto
- Rapporto di Prova tipo 2.2 UNI EN10204
- Certificato di Controllo tipo 3.1 UNI EN10204
- Dichiarazione di Conformità CE

WLL	A	E	€		
kg	mm	mm			
800	32	20,5	11,50	1	080630008
1120	38	20,5	14,50	1	080630011
2000	44,5	22	17,50	1	080630020
3150	44,5	27	22,00	1	080630031

8064S

ganci per sollevamento orientabili (non sotto carico) acciaio al carbonio grado 4

CE

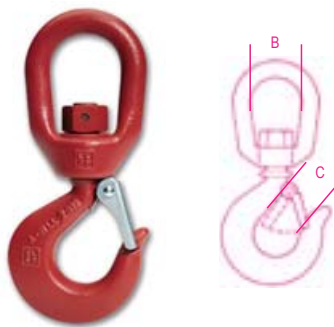

EN 1677-5

DATI TECNICI

- coefficiente di sicurezza: 5
- trattamento termico: bonifica
- codice lotto fabbricazione
- ANALISI DI LABORATORIO
- analisi chimica, analisi metallografica
- test carico di prova (WLL x 2,5)
- test di trazione
- test di fatica (min. 20.000 cicli)

CERTIFICATI DISPONIBILI

- Specifica Prodotto
- Rapporto di Prova tipo 2.2 UNI EN10204
- Certificato di Controllo tipo 3.1 UNI EN10204
- Dichiarazione di Conformità CE

WLL	B	C	€		
kg	mm	mm			
800	31	20	28,50	1	080640107
1000	40	22	39,50	1	080640110
1600	47	23	52,00	1	080640115
2000	47	27	57,00	1	080640120
3200	64	35	99,00	1	080640130
5000	77	43	181,00	1	080640150
7500	90	53	263,00	1	080640175
10000	96	58	438,00	1	080640199

8065SC

ganci per sollevamento girevoli sotto carico, con cuscinetto acciaio al carbonio grado 4

CE

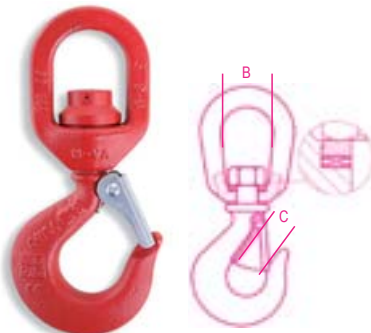

EN 1677-5

DATI TECNICI

- coefficiente di sicurezza: 5
- trattamento termico: bonifica
- codice lotto fabbricazione
- ANALISI DI LABORATORIO
- analisi chimica, analisi metallografica
- test carico di prova (WLL x 2,5)
- test di trazione
- test di fatica (min. 20.000 cicli)

CERTIFICATI DISPONIBILI

- Specifica Prodotto
- Rapporto di Prova tipo 2.2 UNI EN10204
- Certificato di Controllo tipo 3.1 UNI EN10204
- Dichiarazione di Conformità CE

WLL	B	C	€		
kg	mm	mm			
800	38	20	56,50	1	080650107
1000	38	22	61,50	1	080650110
1600	47	23	75,50	1	080650115
2000	47	27	87,00	1	080650120
3200	54	35	152,50	1	080650130
5000	72	43	225,00	1	080650150
7500	82	53	382,00	1	080650175

8062

ganci scorsoi, acciaio legato ad alta resistenza

CE

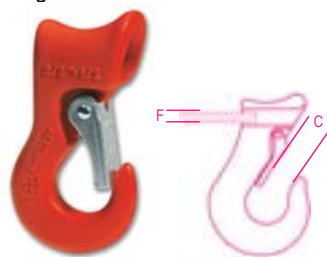

DATI TECNICI

- coefficiente di sicurezza: 5
- trattamento termico: bonifica
- codice lotto fabbricazione
- ANALISI DI LABORATORIO
- analisi chimica, analisi metallografica
- test carico di prova (WLL x 2,5)
- test di trazione

CERTIFICATI DISPONIBILI

- Specifica Prodotto
- Rapporto di Prova tipo 2.2 UNI EN10204
- Certificato di Controllo tipo 3.1 UNI EN10204
- Dichiarazione di Conformità CE

WLL	C	F	€		
kg	mm	mm			
1500	19	10-13	34,00	1	080620013
2000	21	16	48,00	1	080620016
3000	26	18	80,00	1	080620018
5000	34	22-25	107,00	1	080620025

8051S

ganci per sollevamento con sicura acciaio al carbonio zincati

CE



GRADO 4

DATI TECNICI

- coefficiente di sicurezza: 4
- trattamento termico: normalizzazione
- codice lotto di fabbricazione
- ANALISI DI LABORATORIO
- analisi chimica
- analisi metallografica
- test di trazione

CERTIFICATI DISPONIBILI

- Specifica Prodotto
- Rapporto di Prova tipo 2.2 UNI EN10204
- Certificato di Controllo tipo 3.1 UNI EN10204
- Dichiarazione di Conformità CE

WLL	C	F	€		
kg	mm	mm			
250	14	12	2,50	10	080510202
500	18	16,5	5,50	5	080510205

confezioni appendibili



WLL		€		
kg				
250	1	3,50	1	080519202
500	1	6,80	1	080519205

8100

catene per sollevamento, acciaio legato ad alta resistenza grado 8

CE

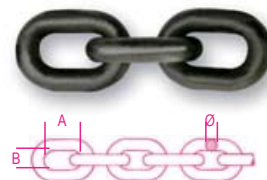

EN 818-2

DATI TECNICI

- coefficiente di sicurezza: 4
- trattamento termico: bonifica
- codice lotto di fabbricazione
- ANALISI DI LABORATORIO
- analisi chimica
- analisi metallografica
- test di trazione

CERTIFICATI DISPONIBILI

- Specifica Prodotto
- Rapporto di Prova tipo 2.2 UNI EN10204
- Certificato del Fabbricante EN818-2
- Dichiarazione di Conformità CE

WLL	Ø	A	B min	€/m	
kg	mm	mm	mm		
1120	6	18	7,8	16,00	1 081000011
1500	7	21	11,0	20,50	1 081000016
2000	8	24	12,0	24,00	1 081000020
3150	10	30	14,5	36,00	1 081000032
5300	13	39	20,0	62,00	1 081000053
8000	16	48	20,8	94,00	1 081000080

* ATTENZIONE: il prodotto viene consegnato in un unico spezzone di catena, salvo diversa indicazione in fase d'ordine!

Robur

8143

paranco manuale a catena

CE



EN13157

DATI TECNICI

- coefficiente di sicurezza: 4
 - piastra di identificazione seriale
- CERTIFICATI DISPONIBILI
- Certificato del Fabbricante
 - Dichiarazione di Conformità CE
 - Rapporto di Prova tipo 2.2 UNI EN10204
 - Specifica Prodotto

WLL H sforzo / effort

t	L m	mm	kg	€		
0,5	3	285	27	172,00	1	081430005
1	3	315	44	204,00	1	081430010
2	3	380	44	295,00	1	081430020
3	3	475	45	380,00	1	081430030
5	3	600	47	565,00	1	081430050

0,5	6	285	27	258,00	1	081430105
1	6	315	44	290,00	1	081430110
2	6	380	44	409,00	1	081430120
3	6	475	45	584,00	1	081430130
5	6	600	47	829,00	1	081430150

8146

paranco a leva

CE



EN13157

DATI TECNICI

- coefficiente di sicurezza: 4
 - piastra di identificazione seriale
- CERTIFICATI DISPONIBILI
- Certificato del Fabbricante
 - Dichiarazione di Conformità CE
 - Rapporto di Prova tipo 2.2 UNI EN10204
 - Specifica Prodotto

WLL H sforzo / effort

t	L m	mm	kg	€		
0,75	1,5	320	21	210,00	1	081460008
1,5	1,5	380	41	300,00	1	081460015
3,0	1,5	480	41	400,00	1	081460030
6,0	1,5	600	46	650,00	1	081460060

0,75	3,0	320	21	235,00	1	081460108
1,5	3,0	380	41	333,00	1	081460115
3,0	3,0	480	41	459,00	1	081460130
6,0	3,0	600	46	779,00	1	081460160

Robur

Robur

8146C

paranco a leva compatto

CE



EN13157

DATI TECNICI

- coefficiente di sicurezza: 4
 - piastra di identificazione seriale
- CERTIFICATI DISPONIBILI
- Certificato del Fabbricante
 - Dichiarazione di Conformità CE
 - Rapporto di Prova tipo 2.2 UNI EN10204
 - Specifica Prodotto

WLL H sforzo / effort

t	L m	mm	kg	€		
0,25	1,5	230	20,7	194,00	1	081460002

8120

catene tipo Genovese
per collegamenti statici,
zincate



DATI TECNICI

- coefficiente di sicurezza: 4
- CERTIFICATI DISPONIBILI
- Specifica Prodotto
- Rapporto di Prova tipo 2.2 UNI EN10204

Ø mm	nr	WFL kg	m	€		
1,5	10	8	150	148,00	1	081200015
1,6	12	15	150	154,50	1	081200016
2,2	14	25	75	90,00	1	081200022
2,7	16	40	75	112,00	1	081200027
3,0	17	55	75	123,50	1	081200030
3,4	18	100	60	123,50	1	081200034
3,8	19	110	50	119,00	1	081200038
4,4	20	200	40	110,50	1	081200044
4,8	21	250	30	102,50	1	081200048
5,5	22	300	25	102,50	1	081200055
5,8	23	310	25	116,00	1	081200058
6,5	24	400	25	131,50	1	081200065
7,5	26	550	20	143,00	1	081200075
* 8,0	27	600	25	207,00	1	081200080
* 9,0	28	800	25	260,00	1	081200090
* 10,0	30	1000	20	263,00	1	081200100
* 12,0	32	1400	15	279,00	1	081200120

Attenzione: prodotto NON destinato al sollevamento
(*) confezionati in MATASSE

8120B

catene tipo Genovese
per collegamenti statici,
zincate



DATI TECNICI

- coefficiente di sicurezza: 4
- CERTIFICATI DISPONIBILI
- Specifica Prodotto
- Rapporto di Prova tipo 2.2 UNI EN10204

Ø mm	nr	WFL kg	m	€		
1,5	10	8	200	184,00	1	081200315
1,6	12	15	200	195,00	1	081200316
2,2	14	25	100	115,00	1	081200322
2,7	16	40	100	147,00	1	081200327
3,0	17	55	75	123,00	1	081200330
3,4	18	100	100	196,00	1	081200334
3,8	19	110	75	170,00	1	081200338
4,4	20	200	50	132,00	1	081200344
4,8	21	250	50	170,00	1	081200348
5,5	22	300	40	159,00	1	081200355
5,8	23	310	30	136,00	1	081200358
6,5	24	400	30	155,00	1	081200365
7,5	26	550	25	172,00	1	081200375
8,0	27	600	15	133,00	1	081200380
9,0	28	800	15	157,00	1	081200390
10,0	30	1000	10	129,00	1	081200400
12,0	32	1400	8	149,00	1	081200420

Attenzione: prodotto NON destinato al sollevamento

8129

catena di delimitazione in metallo
zincata e verniciata bianca e rossa

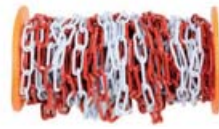

Ø mm	m	€		
5	30	196,00	1	081290050

Attenzione: prodotto NON destinato al sollevamento o ancoraggio

8074

moschettoni
zincati



DIN 5299

DATI TECNICI

- coefficiente di sicurezza: 4
- CERTIFICATI DISPONIBILI
- Specifica Prodotto
- Rapporto di Prova tipo 2.2 UNI EN10204

DxL mm	A mm	WFL kg	€		
* 4x40	6	20	0,48	100	080740040
5x50	7	30	0,49	100	080740050
6x60	8	40	0,55	100	080740060
7x70	9	60	0,70	50	080740070
8x80	11	75	0,85	50	080740080
9x90	12	100	1,15	25	080740090
10x100	13	120	1,55	25	080740100
11x120	16	140	2,10	20	080740101
12x140	22	140	2,95	15	080740102
13x160	24	200	4,00	10	080740103
* 14x180	32	250	8,50	5	080740104

*Misure non contemplate nella norma

8074A

moschettoni con anello
zincati



DIN 5299

DATI TECNICI

- coefficiente di sicurezza: 4
- CERTIFICATI DISPONIBILI
- Specifica Prodotto
- Rapporto di Prova tipo 2.2 UNI EN10204

ØAxL mm	D mm	WFL kg	€		
5x50	7,4	30	0,67	50	080740405
6x60	8,7	40	0,77	50	080740406
8x80	10,5	75	1,05	25	080740408
10x100	13,3	120	1,85	10	080740410

8074G

moschettoni con ghiera
zincati



DATI TECNICI

- coefficiente di sicurezza: 4
- CERTIFICATI DISPONIBILI
- Specifica Prodotto
- Rapporto di Prova tipo 2.2 UNI EN10204

ØAxL mm	D mm	WFL kg	€		
5x50	7,5	30	0,75	50	080740305
6x60	8,5	40	0,87	50	080740306
8x80	10,3	75	1,15	25	080740308
10x100	10,6	120	1,95	10	080740310

8080

maglie rapide di giunzione
zincate

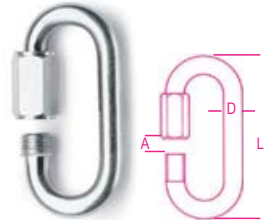

DATI TECNICI

- coefficiente di sicurezza: 4
- CERTIFICATI DISPONIBILI
- Specifica Prodotto
- Rapporto di Prova tipo 2.2 UNI EN10204

DxL mm	A mm	WFL kg	€		
3,5x36	5	20	0,40	100	080800003
4x40	6	30	0,42	100	080800004
5x49	6	50	0,52	100	080800005
6x57	8	60	0,65	100	080800006
7x66	8	100	0,85	50	080800007
8x74	11	140	1,00	50	080800008
9x80	11	160	1,45	25	080800009
10x89	11	220	1,70	25	080800010
12x105	15	300	2,95	20	080800012
14x125	16,5	400	6,30	3	080800014

8082

Anelli
acciaio zincato

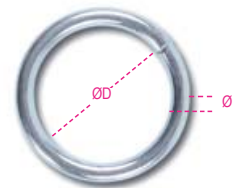

CERTIFICATI DISPONIBILI

- Rapporto di Prova tipo 2.2 UNI EN10204

Ø mm	ØD mm	€		
4	20	0,30	50	080820004
5	30	0,40	20	080820005
6	40	0,65	10	080820006
7	50	1,00	5	080820007
8	60	1,35	5	080820008

8083

ganci a "S"
acciaio zincato



CERTIFICATI DISPONIBILI

• Rapporto di Prova tipo 2.2 UNI EN10204

Ø mm	L mm	€	🚚	📄
3	33	0,07	40	080830003
4	40	0,09	30	080830004
5	47	0,16	20	080830005
6	59	0,31	15	080830006
8	79	0,78	5	080830008

8114

tonichetti in acciaio
tipo Marche
zincati

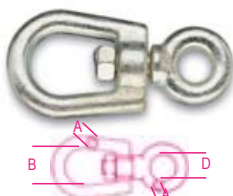

DATI TECNICI

• coefficiente di sicurezza: 4

• codice di identificazione

ANALISI DI LABORATORIO

• test di trazione

CERTIFICATI DISPONIBILI

• Specifica Prodotto

• Rapporto di Prova tipo 2.2 UNI EN10204

• Certificato di Controllo tipo 3.1 UNI EN10204

A mm	B mm	D mm	WFL mm	€	🚚	📄
8	30	16	250	3,20	1	081140008
10	38	18	300	5,90	1	081140010
12	42	20	650	8,60	1	081140012
14	48	22	820	13,20	1	081140014
16	57	24	1000	18,10	1	081140016
18	64	26	1600	21,70	1	081140018
20	72	30	2000	31,50	1	081140020
22	80	34	2500	43,00	1	081140022

8116

tonichetti in acciaio
tipo Sicilia
zincati

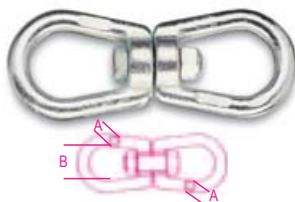

DATI TECNICI

• coefficiente di sicurezza: 4

• codice di identificazione

ANALISI DI LABORATORIO

• test di trazione

CERTIFICATI DISPONIBILI

• Specifica Prodotto

• Rapporto di Prova tipo 2.2 UNI EN10204

• Certificato di Controllo tipo 3.1 UNI EN10204

A mm	B mm	WFL mm	€	🚚	📄
6	23	140	3,40	1	081160006
8	30	250	4,30	1	081160008
10	38	300	7,80	1	081160010
12	42	650	12,80	1	081160012
14	48	820	19,20	1	081160014
16	57	1000	23,70	1	081160016
18	64	1600	29,50	1	081160018
20	72	2000	41,50	1	081160020
22	80	2500	63,50	1	081160022

8317SZ

morsetti simplex
zincati



CERTIFICATI DISPONIBILI

• Rapporto di Prova tipo 2.2 UNI EN10204

Ø mm	L mm	L1 mm	€	🚚	📄
2	15	14	0,19	100	083170102
3	18	16	0,20	100	083170103
4	20	19	0,28	100	083170104
5	24	23	0,32	50	083170105
6	30	27	0,39	30	083170106
8	36	34	0,73	20	083170108
10	42	37	1,10	10	083170110

8317DZ

morsetti duplex
zincati



CERTIFICATI DISPONIBILI

• Rapporto di Prova tipo 2.2 UNI EN10204

Ø mm	L mm	L1 mm	€	🚚	📄
2	30	14	0,25	50	083170002
3	35	15	0,35	50	083170003
4	40	18	0,40	50	083170004
5	50	21	0,50	25	083170005
6	60	25	0,67	20	083170006
8	76	33	1,45	10	083170008
10	95	37	2,20	10	083170010

8381SL

collari per sostegno tubazioni
serie leggera
zincati

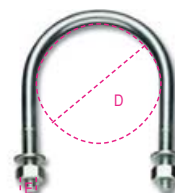

CERTIFICATI DISPONIBILI

• Specifica Prodotto

• Rapporto di Prova tipo 2.2 UNI EN10204

D mm	D gas	E mm	€	🚚	📄
11	1/8"	M6	0,40	100	083810201
14	1/4"	M6	0,42	100	083810202
18	3/8"	M6	0,42	100	083810203
22	1/2"	M6	0,48	100	083810204
27	3/4"	M6	0,48	100	083810205
34	1"	M6	0,54	100	083810206
43	1 1/4"	M6	0,54	100	083810207
49	1 1/2"	M8	0,95	50	083810208
61	2"	M8	1,00	50	083810209
77	2 1/2"	M8	1,20	25	083810210
89	3"	M8	1,28	25	083810211
102	3 1/2"	M8	1,45	25	083810212
115	4"	M8	1,60	25	083810213
168	6"	M10	3,80	25	083810218
220	8"	M10	7,80	10	083810220

8381SP

collari per sostegno tubazioni
serie pesante
zincati

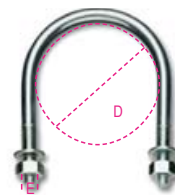

CERTIFICATI DISPONIBILI

• Specifica Prodotto

• Rapporto di Prova tipo 2.2 UNI EN10204

D mm	D gas	E mm	€	🚚	📄
22	1/2"	M8	0,70	100	083810301
27	3/4"	M8	0,76	100	083810302
34	1"	M8	0,82	100	083810303
43	1 1/4"	M8	0,90	100	083810304
49	1 1/2"	M10	1,50	25	083810305
61	2"	M10	1,65	25	083810306
77	2 1/2"	M10	1,90	25	083810307
89	3"	M10	2,00	25	083810308
102	3 1/2"	M12	3,20	25	083810309
115	4"	M12	3,50	15	083810310
168	6"	M16	9,10	15	083810315
220	8"	M16	16,20	10	083810320
274	10"	M16	17,00	1	083810374
274	10"	M20	24,00	1	083810375
324	12"	M20	52,00	1	083810386
408	16"	M24	76,00	1	083810508

 **Robur**

 **Robur**

8383C

collari quadri
zincati a caldo
Dadi flangiati

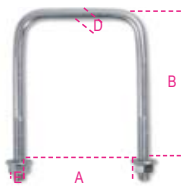

CERTIFICATI DISPONIBILI

- Specifica Prodotto
- Rapporto di Prova tipo 2.2 UNI EN10204

A	E	B	D	€		
mm	mm	mm	mm			
70	M10	110	8,55	1,60	130	083830070
80	M10	120	8,55	1,85	110	083830080
90	M10	130	8,55	2,00	100	083830090
100	M10	155	8,55	2,40	90	083830100
120	M10	175	8,55	2,80	70	083830120

8383P

piastre per collari quadri
zincate a caldo

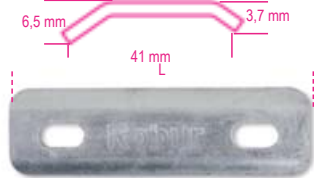

CERTIFICATI DISPONIBILI

- Specifica Prodotto
- Rapporto di Prova tipo 2.2 UNI EN10204

	L	€		
	mm			
8383P 150	150	2,00	150	083830214
8383C/70-80 /90-100				
8383P 170	170	2,40	120	083830217
8383C/100-120				

8515Z

tirafili per agricoltura
zincati

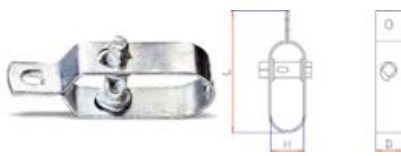

D	H	L	€		
mm	mm	mm			
20	25	93	1,05	50	085150002
24,5	30	100	1,45	50	085150003

8515V

tendifili per agricoltura
zincati e verniciati



D	H	L	€		
mm	mm	mm			
20	25	93	1,40	50	085150102
24,5	30	100	1,75	50	085150103

8515CH

chiavette per tendifili
zincate



L	OA	OB	€		
mm	mm	mm			
90	8	7,5	0,50	20	085150901

8531

grilli tipo pesca
zincati a caldo



CERTIFICATI DISPONIBILI

- Rapporto di Prova tipo 2.2 UNI EN10204

Ø	D	WFL	€		
mm	mm	kg			
20	18	1600	14,40	1	085310018
22	20	2500	21,00	1	085310020

8532

grilli tipo pesca con perno quadro,
verniciati neri



CERTIFICATI DISPONIBILI

- Rapporto di Prova tipo 2.2 UNI EN10204

Ø	D	WFL	€		
mm	mm	kg			
20	20	1600	7,10	1	085320020
22	22	2500	10,80	1	085320022

8535

uncini tipo pesca
zincati

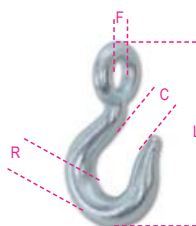

CERTIFICATI DISPONIBILI

- Rapporto di Prova tipo 2.2 UNI EN10204

R	C	F	L	€		
mm	mm	mm	mm			
26	27,5	34	156	16,20	1	085350006
30	36,5	40	185	22,50	1	085350007

8130

catene antifurto in acciaio legato
cementate e bonificate
zincate



CERTIFICATI DISPONIBILI

- Rapporto di Prova tipo 2.2 UNI EN10204

Ø	L	€		
mm	mm			
6	800	11,80	1	081300068
8	1000	25,50	1	081300081
8	1200	29,50	1	081300082
10	1500	44,50	1	081300105

8130A

catene antifurto con anello
acciaio legato, cementate e bonificate
zincate



Ø	L	€		
mm	mm			
10	900	41,50	1	081300209

8131Z

catene antifurto con lucchetto



Ø	L	8139Z	€		
mm	mm	Ø mm			
6	800	8	62,00	1	081310060
6	800	10	67,00	1	081310068
8	1000	10	80,50	1	081310081
8	1200	10	84,50	1	081310082
10	1500	10	99,50	1	081310105

8131DL

bloccadisco con catena antifurto 8130A



Ø	L	€		
mm	mm			
10	900	95,50	1	081310209

8139DL

lucchetti bloccadisco moto, acciaio temprato, PVC antiurto confezionato in blister

- fornito con nr.3 chiavi, cavo segnalatore, astuccio
- adatto a catene 10mm



Ø mm	L mm	H mm	€		
14	108	56	54,00	1	081390214

8139Z

lucchetti per catene antifurto, corpo in lega di zinco confezionato in blister

- fornito con nr.3 chiavi mappate
- adatto a catene 6, 8, 10mm



CERTIFICATI DISPONIBILI

- Rapporto di Prova tipo 2.2 UNI EN10204

Ø mm	L mm	H mm	€		
8	45	90	50,00	1	081390008
10	55	98	55,00	1	081390009

8139ZCH

n.3 chiavi di ricambio neutre per lucchetti 8139Z



8139ZCH	€		
	17,00	1	081390909

adatte per lucchetti Ø8 e Ø10

8050 D1÷D45

kit sicure e ricambi per ganci di sollevamento



	€		
8050D1 8064S-8065SC/800	6,50	1	080500945
8050D2 8064S-8065SC/1000	7,50	1	080500946
8050D3 8064S-8065SC/1600-2000	8,20	1	080500947
8050D4 8055S/5400 - 8064S-8065SC/3200	13,50	1	080500948
8050D5 8055S/8000 8064S-8065SC/5000	15,70	1	080500949
8050D6 8055S/11500 8064S/7500	24,80	1	080500950
8050D10 8062/1500	11,50	1	080500954

8050D11 8062/2000	12,90	1	080500955
8050D12 8062/3000	14,20	1	080500956
8050D13 8062/5000	19,40	1	080500957
8050D22 8055S/16000 8064S/10000	34,00	1	080500966
8050D23 8055S/22000	47,00	1	080500967
8050D24 8051S/250	0,60	1	080500969
8050D25 8051S/500	0,70	1	080500970
8050D29 8061F/5300	19,00	1	080500974
8050D30 8061F/8000	19,00	1	080500975
8050D32 8060/8000	26,00	1	080500977
8050D33 8052/800	2,60	1	080500978
8050D34 8052/1120	2,95	1	080500979
8050D35 8052/2000	3,60	1	080500980
8050D36 8052/3150	3,90	1	080500981
8050D37 8052/4000	4,60	1	080500982
8050D38 8060R/1120	1,70	1	080500983
8050D53 8060R/1500	2,30	1	080500994
8050D39 8060R/2000	2,30	1	080500984
8050D40 8060R/3150	4,00	1	080500985
8050D41 8060R/5300	6,20	1	080500986
8050D42 8063/800	0,60	1	080500987
8050D43 8063/1120	0,85	1	080500988
8050D44 8063/2000	1,10	1	080500989
8050D45 8063/3150	1,35	1	080500990



8050D46 8061R/1120	1,75	1	080500991
8050D47 8061R/2000	1,75	1	080500992
8050D48 8061R/3150	2,40	1	080500993
8050D54 8061R/5300	2,40	1	080500995



8050 D49 8057R/1120 - 8058R/1120	4,80	1	080500849
8050 D50 8057R/2000 - 8058R/2000	5,30	1	080500850
8050 D51 8057R/3150 - 8058R/3150	5,80	1	080500851
8050 D52 8057R/5300 - 8058R/5300	13,00	1	080500852

8058R/PS

kit perni e spine per ganci 8058R-8061R



	Ø mm	€		
8058R/PS	6	5,70	1	080580512
8058R/PS	7-8	6,50	1	080580520
8058R/PS	10	13,00	1	080580532
8058R/PS	13	22,50	1	080580553

8060R/PS

kit perni e spine per ganci 8060R



	Ø mm	€		
8060R/PS	6	5,70	1	080600511
8060R/PS	7	6,50	1	080600515
8060R/PS	8	6,50	1	080600520
8060R/PS	10	13,00	1	080600532
8060R/PS	13	22,50	1	080600553

8143/RK

kit sicure, perni, finecorsa per paranchi manuali a CATENA 8143



	€		
8143/RK 0,5t	7,00	1	081430905
8143/RK 1,0t	8,50	1	081430915
8143/RK 2,0t	11,50	1	081430920
8143/RK 3,0t	13,00	1	081430930
8143/RK 5,0t	15,00	1	081430950

8146/RK

kit sicure, perni, finecorsa per paranchi manuali a LEVA 8146C-8146



	€		
8146/RK 0,25t	5,00	1	081460902
8146/RK 0,75t	8,50	1	081460908
8146/RK 1,50t	10,50	1	081460915
8146/RK 3,00t	12,50	1	081460930
8146/RK 6,00t	14,50	1	081460960



Forze di rottura (BF)
indicata sulle specifiche
tecniche online
WWW.ROBURITALY.COM

8205

tenditore a due occhi
inox AISI 316

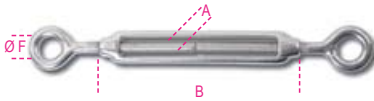

ANALISI DI LABORATORIO

- analisi chimica
- test di trazione

CERTIFICATI DISPONIBILI

- Specifica Prodotto
- Rapporto di Prova tipo 2.2 UNI EN10204

A	B	ø F	WFL	€		
mm	mm	mm	kg			
M4	62	8	75	4,60	10	082050204
M5	72	11	115	5,50	10	082050205
M6	92	12	160	7,30	5	082050206
M8	122	14	300	11,30	5	082050208
M10	150	16	470	16,90	1	082050210
M12	201	18	690	29,50	1	082050212
M14	225	22	940	72,00	1	082050214
M16	244	26	1290	73,50	1	082050216
M20	295	29	2130	106,00	1	082050220
M24	350	33	3000	242,00	1	082050224

8206

tenditore ad occhio e gancio
inox AISI 316

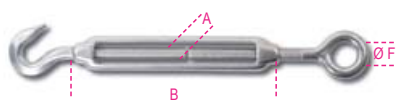

ANALISI DI LABORATORIO

- analisi chimica
- test di trazione

CERTIFICATI DISPONIBILI

- Specifica Prodotto
- Rapporto di Prova tipo 2.2 UNI EN10204

A	B	ø F	WFL	€		
mm	mm	mm	kg			
M5	72	11	25	5,60	10	082060205
M6	92	12	45	7,70	5	082060206
M8	122	14	95	11,70	5	082060208
M10	150	16	140	17,90	1	082060210
M12	201	18	300	30,00	1	082060212
M14	225	22	420	72,50	1	082060214
M16	244	26	570	74,00	1	082060216
M20	295	29	875	108,00	1	082060220

8207

tenditore a due ganci
inox AISI 316

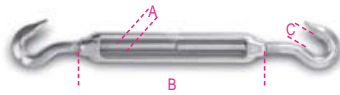

ANALISI DI LABORATORIO

- analisi chimica
- test di trazione

CERTIFICATI DISPONIBILI

- Specifica Prodotto
- Rapporto di Prova tipo 2.2 UNI EN10204

A	B	C	WFL	€		
mm	mm	mm	kg			
M5	72	9	25	5,90	10	082070205
M6	92	9	45	7,80	5	082070206
M8	122	10	95	12,00	5	082070208
M10	150	12	140	18,30	1	082070210
M12	201	14	300	30,50	1	082070212
M14	225	15	420	73,50	1	082070214
M16	244	16	570	75,50	1	082070216
M20	295	19	875	112,00	1	082070220

8209

tenditore a due forcelle
inox AISI 316

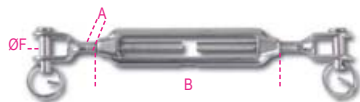

ANALISI DI LABORATORIO

- analisi chimica
- test di trazione

CERTIFICATI DISPONIBILI

- Specifica Prodotto
- Rapporto di Prova tipo 2.2 UNI EN10204

A	B	ø F	WFL	€		
mm	mm	mm	kg			
M5	72	5	115	9,80	5	082090205
M6	92	6	160	11,60	5	082090206
M8	122	8	300	16,70	5	082090208
M10	150	10	470	27,50	1	082090210
M12	201	12	690	44,50	1	082090212
M14	225	14	940	60,00	1	082090214
M16	244	16	1290	89,50	1	082090216
M20	295	20	2130	158,00	1	082090220
M24	350	24	3060	383,00	1	082090224

8210

tenditore a due forcelle con canala a tubo
inox AISI 316

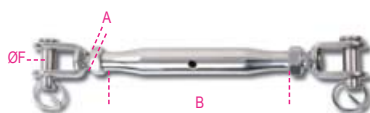

ANALISI DI LABORATORIO

- analisi chimica
- test di trazione

CERTIFICATI DISPONIBILI

- Specifica Prodotto
- Rapporto di Prova tipo 2.2 UNI EN10204

A	B	ø F	WFL	€		
mm	mm	mm	kg			
M5	81	5	115	12,40	3	082100205
M6	92	6	160	14,90	3	082100206
M8	112	8	300	21,90	1	082100208
M10	121	10	470	34,00	1	082100210

A	B	ø F	WFL	€		
mm	mm	mm	kg			
M12	150	12	690	57,00	1	082100212
M14	169	14	940	73,50	1	082100214
M16	190	16	1290	109,00	1	082100216
M20	220	20	2130	189,00	1	082100220

8201T

canaule a tubo
inox AISI 316



ANALISI DI LABORATORIO

- analisi chimica
- test di trazione

CERTIFICATI DISPONIBILI

- Specifica Prodotto
- Rapporto di Prova tipo 2.2 UNI EN10204

ø	ø "	WFL	L	€		
mm		kg	mm			
M6	1/4	160	95	2,80	5	082010406
M8	5/16	300	105	4,05	5	082010408
M10	3/8	470	125	6,85	3	082010410
M12	1/2	690	150	12,00	3	082010412
M14	9/16	940	165	12,70	1	082010414
M16	5/8	1290	190	22,00	1	082010416
M20	3/4	2130	210	33,00	1	082010420

8248

tiranti ad occhio
INOX 316L
destri



UNI 6058

CERTIFICATI DISPONIBILI

- Specifica Prodotto
- Rapporto di Prova tipo 2.2 UNI EN10204

øxL	F	€		
mm	mm			
10x80	8	7,20	1	082480010
10x130	8	9,50	1	082480012
12x95	10	10,90	1	082480016
12x125	10	13,00	1	082480018

8249

viti ad occhio per tasselli
inox AISI 316



ANALISI DI LABORATORIO

- analisi chimica
- test di trazione

CERTIFICATI DISPONIBILI

- Specifica Prodotto
- Rapporto di Prova tipo 2.2 UNI EN10204

A	ø B	D	WFL	€		
mm	mm	mm	kg			
M5	11	50	100	2,00	10	082490205
M6	13	55	160	2,50	10	082490206
M8	17	60	300	4,00	5	082490208
M10	21	80	470	7,20	5	082490210
M12	25	120	690	12,50	1	082490212

8249G

ganci per tasselli
inox AISI 316



ANALISI DI LABORATORIO

- analisi chimica
- test di trazione

CERTIFICATI DISPONIBILI

- Specifica Prodotto
- Rapporto di Prova tipo 2.2 UNI EN10204

A	E	ØF	WFL	€		
mm	mm	mm	kg			
M5	39	9	25	0,95	5	082490305
M6	43	10,5	45	1,15	5	082490306
M8	57	14,5	95	2,00	3	082490308

8216

morsetti
inox AISI 316

CE

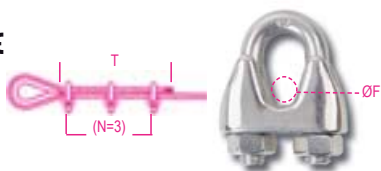

ANALISI DI LABORATORIO

- analisi chimica
- test coppia di serraggio

CERTIFICATI DISPONIBILI

- Specifica Prodotto
- Rapporto di Prova tipo 2.2 UNI EN10204
- Certificato di Conformità CE

ØF	"	T	N	€		
mm						
2	5/64	80	3	2,30	15	082160202
3	1/8	80	3	2,35	15	082160203
4	5/32	80	3	2,65	10	082160204
5	3/16	110	3	3,00	10	082160205
6	1/4	120	5	3,35	10	082160206
8	5/16	210	5	4,50	5	082160208
10	3/8	240	5	6,20	5	082160210
12-13	1/2	300	5	8,70	5	082160213
16	5/8	335	5	12,70	5	082160216
20	3/4	540	5	16,10	5	082160220
22	7/8	595	7	26,00	3	082160222

confezioni appendibili



ØF	"	€		
mm				
2	4	9,70	1	082169402
3	4	9,80	1	082169403
4	4	11,10	1	082169404
5	2	6,70	1	082169405
6	2	7,50	1	082169406
8	2	9,70	1	082169408
10	2	13,20	1	082169410

Robur



8220

radance, tipo pesante
inox AISI 316

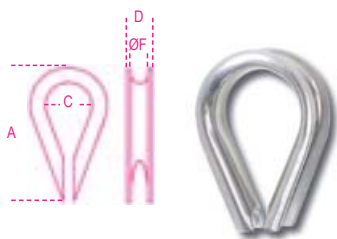

ANALISI DI LABORATORIO

- analisi chimica

CERTIFICATI DISPONIBILI

- Specifica Prodotto
- Rapporto di Prova tipo 2.2 UNI EN10204

ØF	D	A	C	€		
mm	mm	mm	mm			
2	4,5	21	7,5	0,75	15	082200202
3	6	24	10	0,83	15	082200203
4	6,6	28	11	0,95	10	082200204
5	8,5	30	13	1,15	10	082200205
6	10	37	15	1,30	10	082200206
8	12,5	51	23	2,05	5	082200208
10	14,6	56	27	2,50	5	082200210
12	18	68	32	3,40	5	082200212
14	19	69	34	4,50	5	082200214
16	22	83	37	5,00	5	082200216
18	23	81	38	5,90	1	082200218
20	27,8	105	45	7,00	1	082200220
22	29,6	112	45	9,00	1	082200222

8225

grilli diritti
inox AISI 316



ANALISI DI LABORATORIO

- analisi chimica
- test di trazione

CERTIFICATI DISPONIBILI

- Specifica Prodotto
- Rapporto di Prova tipo 2.2 UNI EN10204

ØD	"	A	WFL	€		
mm		mm	kg			
4	5/32	8	50	2,45	10	082250204
5	3/16	11	70	2,70	10	082250205
6	1/4	13	100	2,95	5	082250206
8	5/16	17	250	4,70	5	082250208
10	3/8	21	400	6,85	3	082250210
12	1/2	25	600	11,30	3	082250212
16	5/8	32	1000	24,70	1	082250216
19	3/4	38	1600	41,00	1	082250219
22	7/8	43	2000	64,00	1	082250222
25	1	46	2800	93,50	1	082250225

8227

grilli diritti lunghi
inox AISI 316



ANALISI DI LABORATORIO

- analisi chimica
- test di trazione

CERTIFICATI DISPONIBILI

- Specifica Prodotto
- Rapporto di Prova tipo 2.2 UNI EN10204

ØD	"	A	WFL	€		
mm		mm	kg			
4	5/32	8	50	2,05	10	082270204
5	3/16	10	70	2,35	10	082270205
6	1/4	13,5	100	3,00	5	082270206
8	5/16	17	250	4,85	5	082270208
10	3/8	21	400	8,10	1	082270210
12	1/2	25	600	12,80	1	082270212

8228

grilli a lira
inox AISI 316

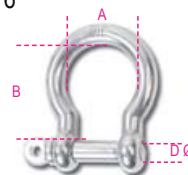

ANALISI DI LABORATORIO

- analisi chimica
- test di trazione

CERTIFICATI DISPONIBILI

- Specifica Prodotto
- Rapporto di Prova tipo 2.2 UNI EN10204

ØD	A	B	WFL	€		
mm	mm	mm	kg			
4	13	20	60	1,85	10	082280204
5	17	23	80	2,15	10	082280205
6	20	27	100	2,45	10	082280206
8	28	36	200	3,90	5	082280208
10	36	44	300	6,20	5	082280210
12	41	53	500	9,90	5	082280212
16	54	74	800	22,30	1	082280216
19	66	86	1100	40,00	1	082280219

Robur

8240F

golfari per sollevamento inox A4
maschio, FORGIATI

CE



DATI TECNICI

- coefficiente di sicurezza: 6
- codice lotto di fabbricazione

ANALISI DI LABORATORIO

- analisi chimica
- analisi metallografica
- test di trazione

CERTIFICATI DISPONIBILI

- Specifica Prodotto
- Rapporto di Prova tipo 2.2 UNI EN10204
- Certificato di Controllo tipo 3.1 UNI EN10204
- Dichiarazione di Conformità CE

ø mm	WLL mm	WLL kg	€	10	5
M6	1,0	120	5,60	4	082400406
* M8	1,25	200	6,20	4	082400408
* M10	1,5	400	10,50	4	082400410
* M12	1,75	600	17,00	4	082400412
* M14	2	1000	27,50	2	082400414
* M16	2	1200	27,50	2	082400416
* M20	2,5	2000	44,50	2	082400420
* M24	3	2700	84,00	2	082400424
* M30	3,5	4000	185,00	1	082400430

(*) Caratteristiche dimensionali DIN 580:2010
WLL incrementato in base a Fascicolo Tecnico Robur
(garantito per accoppiamenti inox-inox)

8240

golfari maschio,
inox AISI 316



ANALISI DI LABORATORIO

- analisi chimica
- test di trazione

CERTIFICATI DISPONIBILI

- Specifica Prodotto
- Rapporto di Prova tipo 2.2 UNI EN10204

A mm	B mm	ø C mm	WFL mm	€	10	5
M6	41	15	90	1,60	10	082400206
M8	50	20	140	2,40	10	082400208
M10	62	25	230	4,75	5	082400210
M12	74	30	340	8,10	5	082400212

8242F

golfari per sollevamento inox A4
femmina, FORGIATI

CE



DATI TECNICI

- coefficiente di sicurezza: 6
- codice lotto di fabbricazione

ANALISI DI LABORATORIO

- analisi chimica
- analisi metallografica
- test di trazione

CERTIFICATI DISPONIBILI

- Specifica Prodotto
- Rapporto di Prova tipo 2.2 UNI EN10204
- Certificato di Controllo tipo 3.1 UNI EN10204
- Dichiarazione di Conformità CE

ø mm	WLL mm	WLL kg	€	10	5
M6	1,0	120	5,60	4	082420406
* M8	1,25	200	6,20	4	082420408
* M10	1,5	400	10,50	4	082420410
* M12	1,75	600	17,00	4	082420412
* M14	2	1000	27,50	2	082420414
* M16	2	1200	27,50	2	082420416
* M20	2,5	2000	44,50	2	082420420
* M24	3	2700	84,00	2	082420424
* M30	3,5	4000	185,00	1	082420430

(*) Caratteristiche dimensionali DIN 582:2010
WLL incrementato in base a Fascicolo Tecnico Robur
(garantito per accoppiamenti inox-inox)

8242

golfari femmina,
inox AISI 316



A mm	B mm	ø C mm	WFL mm	€	10	5
M6	27	15	90	1,60	10	082420206
M8	36	20	140	2,40	10	082420208
M10	45	25	230	4,75	5	082420210
M12	55	30	340	8,10	5	082420212



8274

moschettoni
inox AISI 316

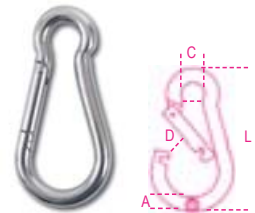

ANALISI DI LABORATORIO

- analisi chimica
- test di trazione

CERTIFICATI DISPONIBILI

- Specifica Prodotto
- Rapporto di Prova tipo 2.2 UNI EN10204

ø A x L mm	ø C mm	D mm	WFL mm	€	10	5
4,5x40	6,5	6	20	2,20	10	082740204
5x50	7	6,5	30	2,20	10	082740205
6x60	8,5	7,5	40	2,30	5	082740206
7x70	10	9	60	2,80	5	082740207
8x80	12	10	75	3,70	5	082740208
9x90	12,5	10,5	100	5,05	5	082740209
10x100	15	13	120	6,30	1	082740210
11x120	19	18	140	9,00	1	082740211
12x140	22	21	140	12,30	1	082740212
13x160	22	26	200	15,50	1	082740213

8274A

moschettoni con anello
inox AISI 316

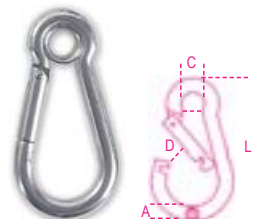

ANALISI DI LABORATORIO

- analisi chimica
- test di trazione

CERTIFICATI DISPONIBILI

- Specifica Prodotto
- Rapporto di Prova tipo 2.2 UNI EN10204

ø A x L mm	ø C mm	D mm	WFL mm	€	10	5
5x50	6,5	7	30	2,15	10	082740405
6x60	7,5	7,5	40	2,60	5	082740406
8x80	9,5	10	75	4,30	5	082740408

8274G

moschettoni con ghiera
inox AISI 316

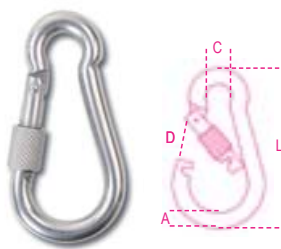

ANALISI DI LABORATORIO

- analisi chimica
- test di trazione

CERTIFICATI DISPONIBILI

- Specifica Prodotto
- Rapporto di Prova tipo 2.2 UNI EN10204

ø A x L	ø C	D	WFL	€		
mm	mm	mm	kg			
6x60	8,5	6,5	40	2,90	5	082740306
8x80	12	8,5	75	5,10	5	082740308
10x100	15	12	120	9,70	3	082740310

8276

moschettoni asimmetrici
inox AISI 316

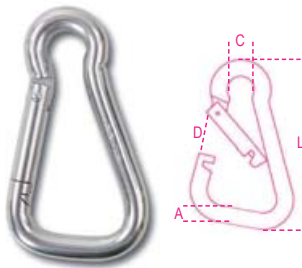

ANALISI DI LABORATORIO

- analisi chimica
- test di trazione

CERTIFICATI DISPONIBILI

- Specifica Prodotto
- Rapporto di Prova tipo 2.2 UNI EN10204

ø A x L	ø C	D	WFL	€		
mm	mm	mm	kg			
6x60	8,5	10	40	2,60	5	082760206
8x80	12	14	75	4,50	5	082760208
10x100	15	18	120	7,90	3	082760210



8276G

moschettoni asimmetrici con ghiera
inox AISI 316

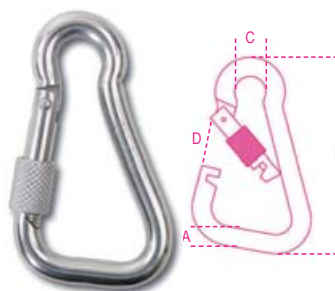

ANALISI DI LABORATORIO

- analisi chimica
- test di trazione

CERTIFICATI DISPONIBILI

- Specifica Prodotto
- Rapporto di Prova tipo 2.2 UNI EN10204

ø A x L	ø C	D	WFL	€		
mm	mm	mm	kg			
6x60	8,5	9	40	3,30	3	082760306
8x80	12	12,5	75	5,90	3	082760308
10x100	15	16	120	10,80	3	082760310

8278

moschettoni trapezoidali
inox AISI 316

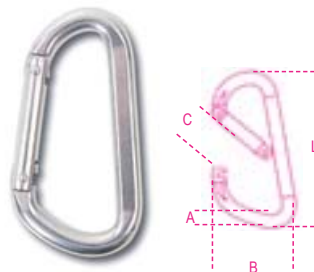

ANALISI DI LABORATORIO

- analisi chimica
- test di trazione

CERTIFICATI DISPONIBILI

- Specifica Prodotto
- Rapporto di Prova tipo 2.2 UNI EN10204

ø A x L	B	C	WFL	€		
mm	mm	mm	kg			
8x80	45	14	75	9,90	3	082780208
10x100	55	16	120	15,50	3	082780210

8280

maglie di giunzione
inox AISI 316

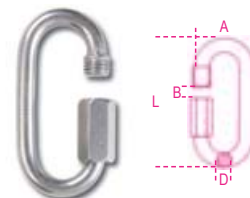

ANALISI DI LABORATORIO

- analisi chimica
- test di trazione

CERTIFICATI DISPONIBILI

- Specifica Prodotto
- Rapporto di Prova tipo 2.2 UNI EN10204

ø D x L	A	B	WFL	€		
mm	mm	mm	kg			
3,5x35	17	5	20	2,55	10	082800203
4x40	19	6	30	2,70	10	082800204
5x50	23	7	50	3,30	5	082800205
6x60	26	8	60	3,90	5	082800206
7x70	30	9	100	4,50	5	082800207
8x80	33	10	140	6,25	1	082800208
10x90	40	12	220	10,20	1	082800210
12x100	47	14	300	15,50	1	082800212

8250

moschettoni a gancio con sicura
inox AISI 316



ANALISI DI LABORATORIO

- analisi chimica
- test di trazione

CERTIFICATI DISPONIBILI

- Specifica Prodotto
- Rapporto di Prova tipo 2.2 UNI EN10204

L	A	ø B	WFL	€		
mm	mm	mm	kg			
50	25	8	40	3,20	5	082500205
70	31	12,5	90	4,80	5	082500207
100	47	20	190	7,90	1	082500210

8264

moschettoni a girello
inox AISI 316



ANALISI DI LABORATORIO

- analisi chimica
- test di trazione

CERTIFICATI DISPONIBILI

- Specifica Prodotto
- Rapporto di Prova tipo 2.2 UNI EN10204

B	L	C	WFL	€		
mm	mm	mm	kg			
12	88	12	60	8,60	5	082640212
16	90	12	60	8,80	5	082640216
19	93	12	60	8,90	1	082640219

8267

moschettoni a gancio con girello e sicura
inox AISI 316



ANALISI DI LABORATORIO

- analisi chimica
 - test di trazione
- CERTIFICATI DISPONIBILI
- Specifica Prodotto
 - Rapporto di Prova tipo 2.2 UNI EN10204

A	L	B	WFL	€		
mm	mm	mm	kg			
10	87	21	30	7,50	5	082670210
12	118	22	70	12,60	1	082670213

8272

girelli a due occhi
inox AISI 316

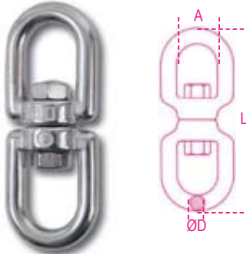

ANALISI DI LABORATORIO

- analisi chimica
 - test di trazione
- CERTIFICATI DISPONIBILI
- Specifica Prodotto
 - Rapporto di Prova tipo 2.2 UNI EN10204

Ø D	A	L	WFL	€		
mm	mm	mm	kg			
4	11	50	90	4,30	5	082720204
5	13	60	115	5,60	5	082720205
6	15	66	140	6,90	5	082720206
8	19	90	250	11,10	3	082720208
10	23	112	300	17,10	1	082720210
13	33	148	650	34,50	1	082720213
16	38	184	1000	64,50	1	082720216
19	40	223	1600	115,00	1	082720219

8273

girelli a sgancio rapido
con occhio girevole
inox AISI 316

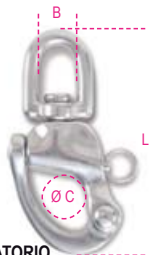

ANALISI DI LABORATORIO

- analisi chimica
 - test di trazione
- CERTIFICATI DISPONIBILI
- Specifica Prodotto
 - Rapporto di Prova tipo 2.2 UNI EN10204

Ø C x L	B	WFL	BF	€		
mm	mm	mm	kg			
12x70	12	230	1100	13,00	1	082730012
16x85	14,50	440	2000	18,00	1	082730016
22x120	20	700	3500	29,00	1	082730022

8282

ganci a "S"
inox AISI 316



ANALISI DI LABORATORIO

- analisi chimica
 - test di trazione
- CERTIFICATI DISPONIBILI
- Specifica Prodotto
 - Rapporto di Prova tipo 2.2 UNI EN10204

Ø D	B1	B2	WFL	€		
mm	mm	mm	kg			
3	7,5	14	4	0,88	10	082820203
4	10,5	14,5	5	1,05	10	082820204
5	12,5	16	12	1,65	10	082820205
6	12,5	18	18	2,20	5	082820206
8	14	23	33	4,15	5	082820208

8282S

ganci a "S" simmetrici
inox AISI 316

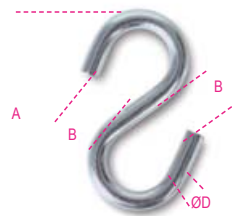

ANALISI DI LABORATORIO

- analisi chimica
 - test di trazione
- CERTIFICATI DISPONIBILI
- Specifica Prodotto
 - Rapporto di Prova tipo 2.2 UNI EN10204

Ø D	B	A	WFL	€		
mm	mm	mm	kg			
3	5,5	34	4	0,24	40	082820303
4	7,0	40	5	0,45	30	082820304
5	9,0	46	12	0,75	20	082820305
6	10	54	18	1,25	15	082820306

8284

terminali gancio a pellicano
inox AISI 316



ANALISI DI LABORATORIO

- analisi chimica
 - test di trazione
- CERTIFICATI DISPONIBILI
- Specifica Prodotto
 - Rapporto di Prova tipo 2.2 UNI EN10204

Ø C	B	L	WFL	€		
mm	mm	mm	kg			
6	11	73	200	12,50	3	082840006
8	14	98	300	17,00	3	082840008
10	23	143	450	35,00	1	082840010

8285

terminali a forcella
inox AISI 316

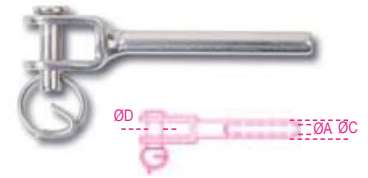

ANALISI DI LABORATORIO

- analisi chimica
 - test di trazione
- CERTIFICATI DISPONIBILI
- Specifica Prodotto
 - Rapporto di Prova tipo 2.2 UNI EN10204

Ø A	Ø C	Ø D	WFL	€		
mm	mm	mm	kg			
3	6,3	6	180	2,50	5	082850203
4	7,5	6	200	4,00	3	082850204
5	9	10	330	5,50	1	082850205
6	12,5	12	720	11,50	1	082850206
8	16	13	1120	16,50	1	082850208

8286

terminali ad occhio
inox AISI 316



ANALISI DI LABORATORIO

- analisi chimica
 - test di trazione
- CERTIFICATI DISPONIBILI
- Specifica Prodotto
 - Rapporto di Prova tipo 2.2 UNI EN10204

Ø D	Ø A	Ø C	WFL	€		
mm	mm	mm	kg			
3	6,5	6,3	180	2,60	5	082860203
4	8,5	7,5	200	3,00	3	082860204
5	10,6	9	330	4,00	1	082860205
6	13	12,5	720	6,60	1	082860206
8	14,7	16	1120	12,00	1	082860208

8287

terminali a tubo
inox AISI 316



ANALISI DI LABORATORIO

- analisi chimica
 - test di trazione
- CERTIFICATI DISPONIBILI
- Specifica Prodotto
 - Rapporto di Prova tipo 2.2 UNI EN10204

Ø D	Ø A	E	WFL	€		
mm	mm	mm	kg			
3	6,3	M6	180	2,25	5	082870203
4	7,5	M8	200	3,20	3	082870204
5	9	M10	330	4,50	1	082870205
6	12,5	M12	720	8,20	1	082870206
8	16	M16	1120	16,50	1	082870208

8290

ponticelli
inox AISI 316



ANALISI DI LABORATORIO

- analisi chimica
- CERTIFICATI DISPONIBILI**
- Specifica Prodotto
- Rapporto di Prova tipo 2.2 UNI EN10204

Ø A mm	B mm	Ø C mm	L mm	€		
5	18	4,3	40	0,80	5	082900205
6	22	5,2	44	1,15	5	082900206
8	23	5,2	51	1,80	5	082900208

8381SX

collari per sostegno tubazioni,
acciaio inox

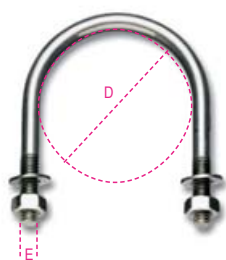

AISI 304

ANALISI DI LABORATORIO

- analisi chimica
- CERTIFICATI DISPONIBILI**
- Rapporto di Prova tipo 2.2 UNIEN10204

D mm	D gas	E mm	€		
11	1/8"	M6	2,00	20	083810401
14	1/4"	M6	2,05	20	083810402
18	3/8"	M6	2,10	20	083810403
22	1/2"	M6	2,15	20	083810404
27	3/4"	M6	2,20	20	083810405
34	1"	M6	2,30	20	083810406
43	1"1/4	M6	2,65	20	083810407
49	1"1/2	M8	4,70	10	083810408
61	2"	M8	5,25	10	083810409
77	2"1/2	M8	6,05	10	083810410
89	3"	M8	6,70	10	083810412
115	4"	M8	8,70	10	083810413
168	6"	M10	16,50	1	083810416
220	8"	M10	20,00	1	083810418

8279

catene tipo Genovese
per collegamenti statici
INOX Aisi 304



DATI TECNICI

- coefficiente di sicurezza: 4
- CERTIFICATI DISPONIBILI**
- Specifica Prodotto
- Rapporto di Prova tipo 2.2 UNI EN10204

Ø mm	nr	WFL kg	m	€		
2	13	20	50	195,00	1	082790020
3	17	55	50	355,00	1	082790030
4	19	100	50	500,00	1	082790040
5	21	250	40	535,00	1	082790050
6	23	310	30	545,00	1	082790060

Attenzione: prodotto NON destinato al sollevamento

8293

systemi di legatura a cricchetto AISI 304
nastro in poliestere ad alta tenacità LC 300kg
ganci uncino

in confezione appendibile

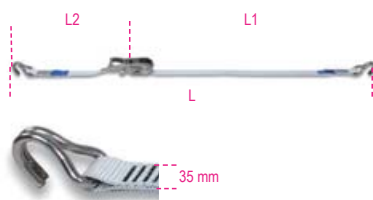

L m	L2 mm	L1 mm	STF daN	€		
6	5700	300	100	56,00	1	082930106

LC = 300 kg

8297C

systemi di legatura ad anello
con mini cricchetto AISI 304
nastro in poliestere ad alta tenacità LC 700kg

in confezione appendibile

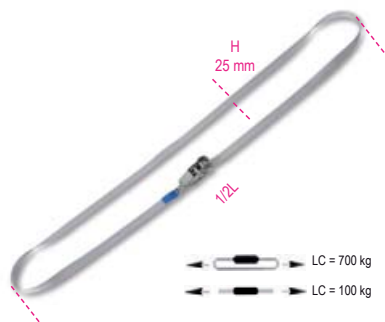

LC = 700 kg
LC = 100 kg

L m	H mm	€		
5	25	30,00	1	082970350

LC = 700 kg

8297F

2 sistemi di legatura ad anello
con fibbia AISI 304
nastro in poliestere ad alta tenacità LC 250kg

in confezione appendibile

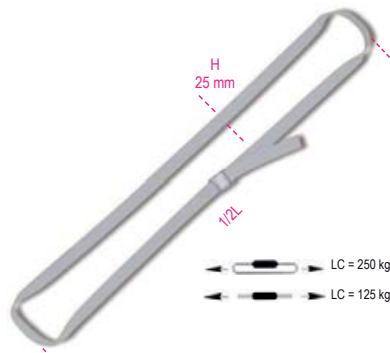

LC = 250 kg
LC = 125 kg

L m	H mm	€		
3	25	30,00	1	082970230

LC = 250 kg

BRACHE DI NASTRO IN POLIESTERE UNI EN1492-1 e UNI EN1492-2

DATI TECNICI

- coefficiente di sicurezza: 7
- codice lotto di fabbricazione

ANALISI DI LABORATORIO

- test di trazione

CERTIFICATI DISPONIBILI

- Specifica Prodotto
- Rapporto di Prova tipo 2.2 UNI EN10204
- Certificato del Fabbricate UNI EN1492
- Dichiarazione di Conformità CE

			β= 0°+45°	β= 45°+60°
	1t	0,8t	2t	1,4t
30	2t	1,6t	4t	2,8t
60	3t	2,4t	6t	4,2t
90	4t	3,2t	8t	5,6t
120	5t	4,0t	10t	7,0t
150	6t	4,8t	12t	8,4t
180	8t	6,4t	16t	11,2t
240	10t	8,0t	20t	14,0t
300				

8150

brache per sollevamento 1t viola
nastro piatto a due strati, asole rinforzate,
poliestere alta tenacità (PES)

CE



UNI EN 1492-1

L m	H mm	WLL ton	€		
0,5	30	1	5,60	1	081500005
1	30	1	7,10	1	081500010
1,5	30	1	9,10	1	081500015
2	30	1	10,00	1	081500020
2,5	30	1	11,60	1	081500025
3	30	1	12,80	1	081500030
4	30	1	16,50	1	081500040
5	30	1	19,30	1	081500050
6	30	1	22,70	1	081500060
8	30	1	29,50	1	081500080





8153

brache per sollevamento 2t verde
nastro piatto a due strati, asole rinforzate,
poliestere alta tenacità (PES)

CE

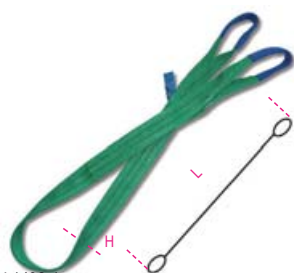

UNI EN 1492-1

L m	H mm	WLL ton	€	📄	📦
1	60	2	11,20	1	081530010
1,5	60	2	15,00	1	081530015
2	60	2	17,30	1	081530020
2,5	60	2	20,20	1	081530025
3	60	2	23,50	1	081530030
4	60	2	29,50	1	081530040
5	60	2	35,50	1	081530050
6	60	2	41,50	1	081530060
8	60	2	53,50	1	081530080
10	60	2	65,00	1	081530100

8156

brache per sollevamento 3t giallo
nastro piatto a due strati, asole rinforzate,
poliestere alta tenacità (PES)

CE

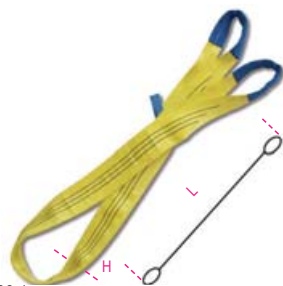

UNI EN 1492-1

L m	H mm	WLL ton	€	📄	📦
1	90	3	15,80	1	081560010
1,5	90	3	21,00	1	081560015
2	90	3	26,00	1	081560020
2,5	90	3	31,00	1	081560025
3	90	3	36,00	1	081560030
4	90	3	45,00	1	081560040
5	90	3	54,00	1	081560050
6	90	3	63,00	1	081560060
8	90	3	82,00	1	081560080
10	90	3	100,00	1	081560100
12	90	3	126,00	1	081560120

8157

brache per sollevamento 4t grigio
nastro piatto a due strati, asole rinforzate,
poliestere alta tenacità (PES)

CE



UNI EN 1492-1

L m	H mm	WLL ton	€	📄	📦
2	120	4	35,50	1	081570020
3	120	4	47,50	1	081570030
4	120	4	61,00	1	081570040
5	120	4	73,50	1	081570050
6	120	4	86,00	1	081570060
8	120	4	112,00	1	081570080
10	120	4	137,00	1	081570100
12	120	4	172,00	1	081570120

8158

brache per sollevamento 5t rosso
nastro piatto a due strati, asole rinforzate,
poliestere alta tenacità (PES)

CE



UNI EN 1492-1

L m	H mm	WLL ton	€	📄	📦
2	150	5	48,50	1	081580020
3	150	5	65,00	1	081580030
4	150	5	83,00	1	081580040
5	150	5	99,00	1	081580050
6	150	5	117,00	1	081580060
8	150	5	151,00	1	081580080
10	150	5	185,00	1	081580100
12	150	5	233,00	1	081580120

8159

brache per sollevamento 6t marrone
nastro piatto a due strati, asole rinforzate,
poliestere alta tenacità (PES)

CE

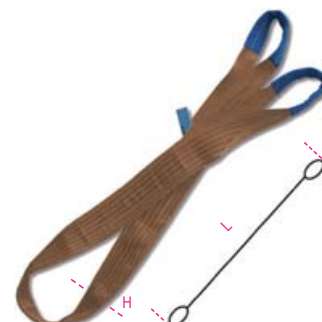

UNI EN 1492-1

L m	H mm	WLL ton	€	📄	📦
2	180	6	61,00	1	081590020
3	180	6	90,00	1	081590030
4	180	6	115,00	1	081590040
5	180	6	139,00	1	081590050
6	180	6	163,00	1	081590060
8	180	6	212,00	1	081590080
10	180	6	262,00	1	081590100



8160

brache per sollevamento 8t blu
nastro piatto a due strati, asole rinforzate,
poliestere alta tenacità (PES)

CE

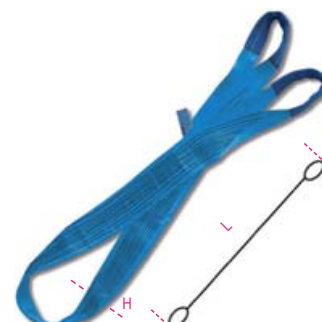

UNI EN 1492-1

L m	H mm	WLL ton	€	📄	📦
3	240	8	124,00	1	081600030
4	240	8	157,00	1	081600040
5	240	8	187,00	1	081600050
6	240	8	222,00	1	081600060
8	240	8	285,00	1	081600080
10	240	8	355,00	1	081600100



8161

brache per sollevamento 10t arancio
nastro piatto a due strati, asole rinforzate,
poliestere alta tenacità (PES)

CE



UNI EN 1492-1

L m	H mm	WLL ton	€	📄	📦
3	300	10	170,00	1	081610030
4	300	10	250,00	1	081610040
5	300	10	300,00	1	081610050
6	300	10	350,00	1	081610060
8	300	10	460,00	1	081610080
10	300	10	560,00	1	081610100
12	300	10	675,00	1	081610120

8170

brache per sollevamento 1t
nastro ad anello continuo, viola
tessuto in poliestere ad alta tenacità (PES)

CE



UNI EN 1492-2

L m	WLL ton	H mm	€	📄	📦
0,5	1	45	5,30	1	081700010
1	1	45	7,20	1	081700020
1,5	1	45	10,20	1	081700030
2	1	45	13,20	1	081700040
3	1	45	19,20	1	081700060
4	1	45	25,50	1	081700080
5	1	45	32,00	1	081700100



8173

brache per sollevamento 2t
nastro ad anello continuo, verde
tessuto in poliestere ad alta tenacità (PES)

CE

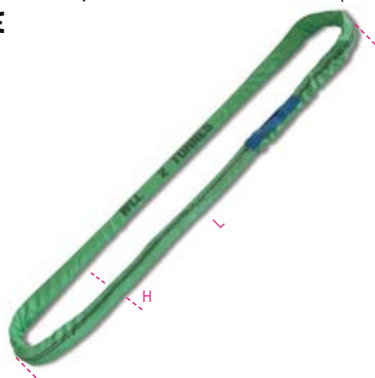

UNI EN 1492-2

L m	H mm	WLL ton	€	📄	📦
0,5	50	2	7,20	1	081730010
1	50	2	11,00	1	081730020
1,5	50	2	16,00	1	081730030
2	50	2	21,00	1	081730040
2,5	50	2	26,00	1	081730050
3	50	2	31,00	1	081730060
4	50	2	41,00	1	081730080
5	50	2	51,50	1	081730100
6	50	2	62,00	1	081730120
8	50	2	81,00	1	081730160

8176

brache per sollevamento 3t
nastro ad anello continuo, giallo
tessuto in poliestere ad alta tenacità (PES)

CE



UNI EN 1492-2

L m	H mm	WLL ton	€	📄	📦
1	60	3	14,50	1	081760020
1,5	60	3	21,00	1	081760030
2	60	3	27,50	1	081760040
2,5	60	3	34,00	1	081760050
3	60	3	40,50	1	081760060
4	60	3	54,50	1	081760080
5	60	3	68,50	1	081760100
6	60	3	82,00	1	081760120
8	60	3	108,00	1	081760160

8177

brache per sollevamento 4t
nastro ad anello continuo, grigio
tessuto in poliestere ad alta tenacità (PES)

CE



UNI EN 1492-2

L m	H mm	WLL ton	€	📄	📦
1	65	4	17,20	1	081770020
1,5	65	4	25,50	1	081770030
2	65	4	33,50	1	081770040
2,5	65	4	41,50	1	081770050
3	65	4	49,50	1	081770060
4	65	4	65,00	1	081770080
5	65	4	82,00	1	081770100
6	65	4	98,00	1	081770120
8	65	4	130,00	1	081770160

8178

brache per sollevamento 5t
nastro ad anello continuo, rosso
tessuto in poliestere ad alta tenacità (PES)

CE

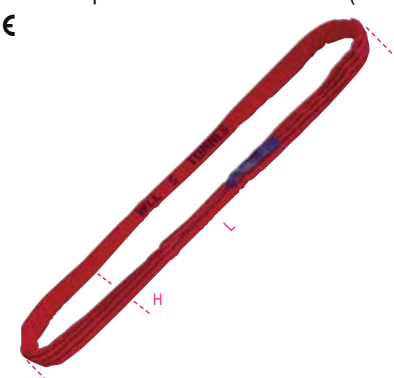

UNI EN 1492-2

L m	H mm	WLL ton	€	📄	📦
1	70	5	21,50	1	081780020
1,5	70	5	32,00	1	081780030
2	70	5	41,50	1	081780040
2,5	70	5	51,00	1	081780050
3	70	5	61,00	1	081780060
4	70	5	81,00	1	081780080
5	70	5	102,00	1	081780100
6	70	5	121,00	1	081780120
8	70	5	162,00	1	081780160





8179M

brache per sollevamento 6t
nastro ad anello continuo, marrone
tessuto in poliestere ad alta tenacità (PES)

CE

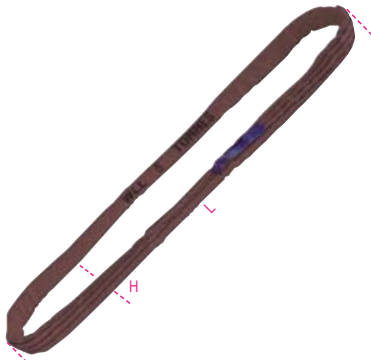

UNI EN 1492-2

L m	H mm	WLL ton	€		
3	80	6	75,00	1	081790060
4	80	6	100,00	1	081790080
6	80	6	149,00	1	081790120
8	80	6	199,00	1	081790160

8179B

brache per sollevamento 8t
nastro ad anello continuo, blu
tessuto in poliestere ad alta tenacità (PES)

CE

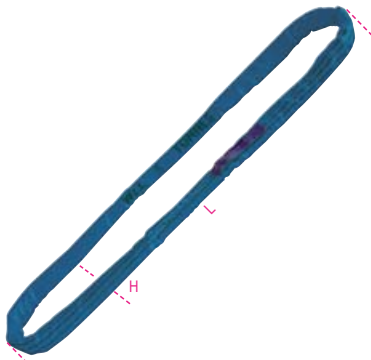

UNI EN 1492-2

L m	H mm	WLL ton	€		
1	85	8	34,50	1	081790220
3	85	8	99,00	1	081790260
4	85	8	132,00	1	081790280
6	85	8	198,00	1	081790320
8	85	8	264,00	1	081790360

8179A

brache per sollevamento 10t
nastro ad anello continuo, arancio
tessuto in poliestere ad alta tenacità (PES)

CE



UNI EN 1492-2

L m	H mm	WLL ton	€		
3	95	10	150,00	1	081790506
4	95	10	195,00	1	081790508
6	95	10	290,00	1	081790512
8	95	10	355,00	1	081790516
10	95	10	485,00	1	081790520

8090F

maglie di giunzione da sollevamento,
per brache in poliestere,
acciaio legato ad alta resistenza
grado 8

CE

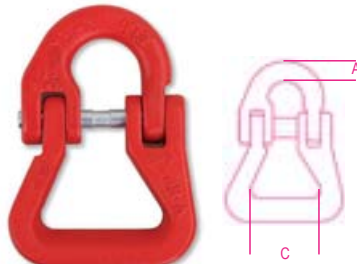

EN 1677-1

DATI TECNICI

- coefficiente di sicurezza: 4
- trattamento termico: bonifica
- codice lotto fabbricazione
- ANALISI DI LABORATORIO
- analisi chimica, analisi metallografica
- test carico di prova (WLL x 2,5)
- test di trazione
- test di fatica (min. 20.000 cicli)
- CERTIFICATI DISPONIBILI
- Specifica Prodotto
- Rapporto di Prova tipo 2.2 UNI EN10204
- Certificato di Controllo tipo 3.1 UNI EN10204
- Dichiarazione di Conformità CE

WLL kg	Ø mm	A mm	C mm	€		
2000	7-8	10,5	40	26,50	1	080900220
3150	10	12	50	33,00	1	080900232
5300	13	17	60	50,50	1	080900253
8000	16	21	75	77,00	1	080900280



8166

guaine antiabrasione per brache di
sollevamento,
in poliestere ad alta tenacità (PES)
con sottostrato elastomerico



H mm	Ø mm	L m	€		
70	45	3	21,50	1	081660073
80	52	3	25,00	1	081660083
110	70	3	30,50	1	081660103
155	100	3	63,50	1	081660153
170	110	3	71,00	1	081660170
235	150	4	192,00	1	081660235

H mm			
70	8150	8170-8173	081660073
80	8153	8176	081660083
110	8153-8156	8177-8178	081660103
155	8157	8178-8179A 8179B-8179M	081660153
170	8158	-	081660170
235	8159	-	081660235

SISTEMI DI ANCORAGGIO E LEGATURA

UNI EN 12195 DATI TECNICI

- coefficiente di sicurezza: 2
- codice di identificazione
- ANALISI DI LABORATORIO
- test pretensionabilità cricchetto
- test di deformazione parti metalliche
- test di trazione sistema completo

CERTIFICATI DISPONIBILI

- Specifica Prodotto
- Rapporto di Prova tipo 2.2 UNI EN10204

8180

sistemi di ancoraggio a cricchetto LC 750kg
nastro in poliestere ad alta tenacità (PES)
ganci a uncino

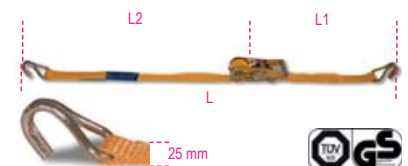

EN 12195-2

L m	L2 mm	L1 mm	€		
4	3750	250	14,00	1	081800004
6	5750	250	16,00	1	081800006
8	7750	250	18,00	1	081800008

LC = 750 kg

8181

systemi di ancoraggio a cricchetto LC 1000kg
nastro in poliestere ad alta tenacità (PES)
ganci a uncino

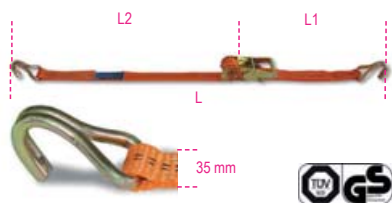

EN 12195-2

L m	L2 mm	L1 mm	€		
4	3600	400	17,00	1	081810004
6	5600	400	19,50	1	081810006
8	7600	400	21,50	1	081810008

LC = 1000 kg

8181S

systemi di ancoraggio a cricchetto LC 1000kg
nastro in poliestere ad alta tenacità (PES)
ganci sponda

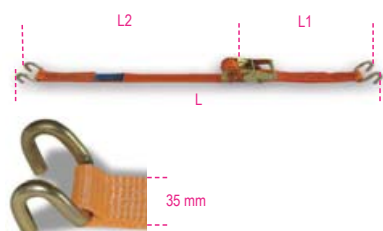

EN 12195-2

L m	L2 mm	L1 mm	STF daN	€	
6	5600	400	180	19,00	1 081810206

LC = 1000 kg

8182T

systemi di ancoraggio a cricchetto LC 1500kg
nastro in poliestere ad alta tenacità (PES)
ganci a uncino

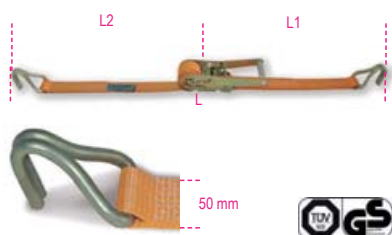

EN 12195-2

L m	L1 mm	L2 mm	€		
8,5	400	8100	30,00	1	081821085
10,5	400	10100	33,50	1	081821105

LC = 1500 kg

8182

systemi di ancoraggio a cricchetto LC 2000kg
nastro in poliestere ad alta tenacità (PES)
ganci a uncino

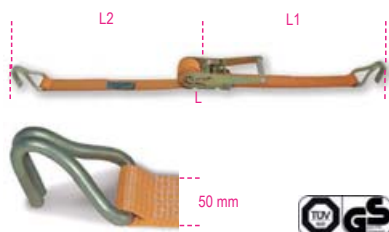

EN 12195-2

L m	L2 mm	L1 mm	€		
4,5	4100	400	27,00	1	081820045
6,5	6100	400	32,00	1	081820065
8,5	8100	400	36,00	1	081820085
10,5	10100	400	39,50	1	081820105
14,5	14100	400	45,50	1	081820145
16,5	16100	400	50,00	1	081820165

LC = 2000 kg

	L2 mm	L1 mm	€		
8182LP parte lunga	8100		19,00	1	081820902
8182SP parte corta e cricchetto		400	19,50	1	081820905

8182H

systemi di ancoraggio a cricchetto LC 2500kg
nastro in poliestere ad alta tenacità (PES)
ganci a uncino

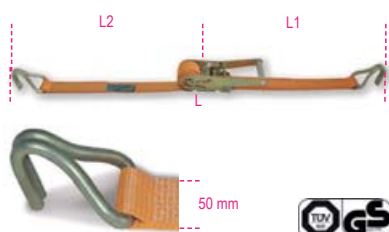

EN 12195-2

L m	L1 mm	L2 mm	€		
6,5	400	6100	34,50	1	081820406
8,5	400	8100	38,00	1	081820408
10,5	400	10100	41,50	1	081820410
14,5	400	14100	53,00	1	081820414

LC = 2500 kg

8182TS

systemi di ancoraggio a cricchetto LC 1500kg
nastro in poliestere ad alta tenacità (PES)
ganci sponda

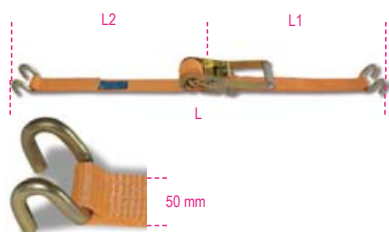

EN 12195-2

L m	L1 mm	L2 mm	€		
8,5	400	8100	31,00	1	081821285
10,5	400	10100	34,50	1	081821305

LC = 1500 kg

8182S

systemi di ancoraggio a cricchetto LC 2000kg
nastro in poliestere ad alta tenacità (PES)
ganci sponda

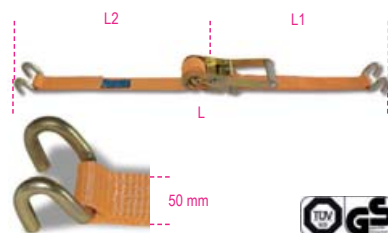

EN 12195-2

L m	L2 mm	L1 mm	€		
6,5	6100	400	31,50	1	081820265
8,5	8100	400	35,50	1	081820285
10,5	10100	400	39,50	1	081820305

LC = 2000 kg

	L2 mm	L1 mm	€		
8182SLP parte lunga	8100		18,50	1	081820912
8182SSP parte corta e cricchetto		400	19,00	1	081820915

8184

systemi di ancoraggio a cricchetto inverso a
leva lunga LC 2500kg
nastro in poliestere ad alta tenacità (PES)
ganci a uncino



EN12195-2

L m	L2 mm	L1 mm	STF daN	€	
6,5	6100	400	500	32,00	1 081840065
8,5	8100	400	500	34,00	1 081840085
10,5	10100	400	500	37,00	1 081840105

LC = 2500 kg

8183

systemi di ancoraggio a cricchetto LC 5000kg
nastro in poliestere ad alta tenacità (PES)
ganci a uncino



EN 12195-2

L m	L2 mm	L1 mm	STF daN	€	
8,5	8000	500	500	110,00	1 081830085
12,5	12000	500	500	130,00	1 081830125

LC = 5000 kg



8190

tendicatena di ancoraggio a cricchetto con due ganci per brache di ancoraggio 8190B Ø 8 e 10mm
Grado 8



EN12195/3

DATI TECNICI

- coefficiente di sicurezza: 2
- trattamento termico: ganci bonificati

codice lotto

ANALISI DI LABORATORIO

- analisi chimica, analisi metallografica
- test di trazione

CERTIFICATI DISPONIBILI

- Specifica Prodotto
- Rapporto di Prova tipo 2.2 UNI EN10204
- Certificato di Controllo tipo 3.1 UNI EN10204

Ø mm	LC daN	Ø mm	LC daN	€	1	081900010
10	6300	8	4000	76,00	1	081900010

* ATTENZIONE: il prodotto può essere utilizzato con catena 8mm con opportuna riduzione del carico (LC 4000daN)

8190B

catene di ancoraggio carichi per tendicatena a cricchetto 8190
Grado 8



EN12195/3

DATI TECNICI

- coefficiente di sicurezza: 2
- trattamento termico: bonifica
- piastrina di identificazione seriale

ANALISI DI LABORATORIO

- analisi chimica,
- analisi metallografica
- test carico di rottura

CERTIFICATI ALLEGATI

- Certificato del Fabbricante
- Rapporto di Prova tipo 2.2 UNI EN10204

CERTIFICATI DISPONIBILI

- Specifica Prodotto

Ø mm	LC daN	L m	L1 m	€	1	081901308
8	4000	3,5	3,30	146,00	1	081901308
10	6300	3,5	3,28	221,00	1	081901310



8182A

sistemi di ancoraggio a cricchetto con 2 asole
nastro in poliestere ad alta tenacità (PES)
LC 2000kg



EN 12195-2

L m	L2 mm	L1 mm	STF daN	€	1	081820585
8,5	8100	400	300	35,50	1	081820585

LC = 2000 kg

8182E

sistemi di ancoraggio a cricchetto per interni
furgoni e autocarri, LC 1000kg
nastro in poliestere ad alta tenacità (PES)



EN 12195-2

L m	L2 mm	L1 mm	H mm	€	1	081820440
4	3500	500	50	19,50	1	081820440

LC = 1000 kg

	L2 mm	L1 mm	€	1	
8182EL	2500		6,00	1	081820942
parte lunga					
8182EC		1500	13,00	1	081820945
parte corta e cricchetto					

8185

sistemi di ancoraggio ad anello LC 1500kg
con cricchetto tenditore
nastro in poliestere ad alta tenacità (PES)



EN 12195-2

L m	STF daN	€	1	081850005
5	200	11,50	1	081850005
8	200	14,00	1	081850008

8186

sistemi di ancoraggio ad anello LC 2000kg
con cricchetto tenditore
nastro in poliestere ad alta tenacità (PES)



EN 12195-2

L m	STF daN	€	1	081860005
5	180	14,00	1	081860005
8	180	17,50	1	081860008

8187

sistemi di ancoraggio ad anello LC 4000kg
con cricchetto tenditore
nastro in poliestere ad alta tenacità (PES)



EN 12195-2

L m	STF daN	€	1	081870005
5	350	25,50	1	081870005
8	350	30,00	1	081870008



8188C

sistemi di legatura ad anello LC 800kg
con cricchetto tenditore
nastro in poliestere ad alta tenacità (PES)



1,5 m
5,0 m



EN 12195-2

L m	STF daN	€		
1,5	72	4,40	3	081880315
5	72	6,50	3	081880350

8188CG/25

sistemi di legatura con 2 ganci ed asole,
cricchetto tenditore LC 400kg
nastro in poliestere ad alta tenacità (PES)



EN 12195-2

L m	L1 mm	L2 mm	€	
3	480	170	9,60	1 081880430
5	480	170	10,50	1 081880450

8188CU/25

sistemi di legatura con ganci uncino,
cricchetto tenditore LC 400kg
nastro in poliestere ad alta tenacità (PES)



EN 12195-2

L m	L1 mm	L2 mm	€	
5	300	4700	10,00	1 081880750

8188F

sistemi di legatura ad anello LC 200kg
con fibbia di serraggio
nastro in polipropilene ad alta tenacità (PP)

1,5 m
2,0 m
2,5 m
3,0 m
5,0 m

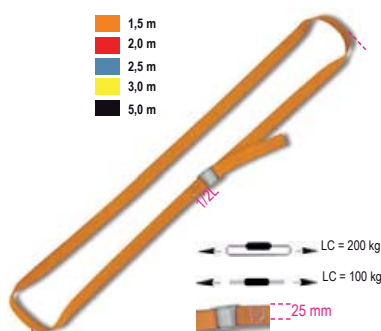

EN 12195-2

L m	€		
1,5	2,50	10	081880215
2,0	2,70	10	081880220
2,5	3,00	10	081880225
3,0	3,20	10	081880230
5,0	4,00	6	081880250

8188F35

sistemi di legatura ad anello LC 500kg
con fibbia di serraggio
nastro in polipropilene ad alta tenacità (PP)



EN 12195-2

L m	€		
5	9,00	1	081880295

8188VFG2

sistemi di legatura con 2 ganci ed asole,
fibbia di serraggio LC 250kg
nastro in polipropilene ad alta tenacità (PP)



EN 12195-2

L m	L1 mm	L2 mm	€	
3	450	110	12,80	1 081881530

8189

nastro di legatura
poliestere (PES), in rotoli
pezze con lunghezza variabile: minima continua garantita 30m



H mm	L m	LC kg	€		
25	100	750	93,00	1	081890902
35	100	1000	117,00	1	081890903
50	100	2000	188,00	1	081890905

8189A

Tappetino antiscivolo
per il fissaggio del carico



L m	H mm	S mm	μ	€	
5	250 mm	8	0,6	65,00	1 081890525

8189PA

2 protezioni angolari
per nastri di ancoraggio in poliestere



L1xL2 mm	H1 mm	H2 mm	€	
100x60	60	12	1,70	1 081890060
135x90	60	18	4,00	1 081890090



Articolo	Rapporto di Prova 2.2 (UNI EN 10204)	Certificato di Controllo 3.1 (UNI EN 10204)	Certificato del fabbricante	Dichiarazione di Conformità CE
8001Z	✓	✓		✓
8001TZ	✓	✓		✓
8002ZD	✓			
8003ZD	✓			
8004ND	✓			
8005Z	✓			✓
8005TZ	✓			✓
8006Z	✓			✓
8007Z	✓			✓
8008N	✓			✓
8008TZN	✓			✓
8009FD	✓			
8009Z	✓			✓
8009TZ	✓			✓
8010Z	✓			✓
8010TZ	✓			
8016	✓			✓
8016DA	✓			✓
8016FR	✓			
8016U2	✓		✓	✓
8016UGK	✓		✓	✓
8018E	✓			
8018T	✓			
8020	✓			
8021	✓			
8025	✓	✓		✓
8026A	✓	✓		✓
8026R	✓	✓		✓
8028	✓	✓		✓
8029R	✓	✓		✓
8031R	✓	✓		✓
8032	✓	✓		✓
8040EN	✓	✓		✓
8040EZ	✓	✓		✓
8042EN	✓	✓		✓
8042EZ	✓	✓		✓
8041	✓	✓		✓
8043	✓	✓		✓
8044	✓	✓		✓
8048	✓			
8049	✓	✓		✓
8049A	✓	✓		✓
8051S	✓	✓		✓
8052	✓	✓		✓
8057R	✓	✓		✓
8058R	✓	✓		✓
8060R	✓	✓		✓
8061R	✓	✓		✓
8062	✓	✓		✓
8063	✓	✓		✓
8064S	✓	✓		✓
8065SC	✓	✓		✓
8074	✓			
8074A	✓			
8074G	✓			
8080	✓			
8085R	✓	✓		✓
8086	✓	✓		✓
8090	✓	✓		✓
8090F	✓	✓		✓
8090R	✓	✓		✓
8091			✓	✓
8091SL			✓	✓

Articolo	Rapporto di Prova 2.2 (UNI EN 10204)	Certificato di Controllo 3.1 (UNI EN 10204)	Certificato del fabbricante	Dichiarazione di Conformità CE
8092			✓	✓
8092SL			✓	✓
8094			✓	✓
8094SL			✓	✓
8096			✓	✓
8096SL			✓	✓
8097			✓	✓
8097SL			✓	✓
8098			✓	✓
8098SL			✓	✓
8100	✓	✓		✓
8105	✓	✓		✓
8109	✓	✓		✓
8110	✓			
8114	✓			
8116	✓			
8120	✓			
8120B	✓			
8130A	✓			
8139DL	✓			
8143	✓		✓	✓
8146	✓		✓	✓
8146K	✓		✓	✓
8150	✓		✓	✓
8153	✓		✓	✓
8156	✓		✓	✓
8157	✓		✓	✓
8158	✓		✓	✓
8159	✓		✓	✓
8160	✓		✓	✓
8161	✓		✓	✓
8166	✓			
8170	✓		✓	✓
8173	✓		✓	✓
8176	✓		✓	✓
8177	✓		✓	✓
8178	✓		✓	✓
8179M-B-A	✓		✓	✓
8180	✓			
8181	✓			
8181S	✓			
8182	✓			
8182A	✓			
8182E	✓			
8182H	✓			
8182M	✓			
8182S	✓			
8182T	✓			
8182T-TS	✓			
8182TS	✓			
8185	✓			
8186	✓			
8187	✓			
8188C	✓			
8188CG/25	✓			
8188CU	✓			
8188F	✓			
8188VF/35	✓			
8188FG2	✓			
8190	✓	✓		
8190B	✓		✓	
8302Z	✓			
8303Z	✓			

Articolo	Rapporto di Prova 2.2 (UNI EN 10204)	Certificato di Controllo 3.1 (UNI EN 10204)	Certificato del fabbricante	Dichiarazione di Conformità CE
8317DZ	✓			
8317SZ	✓			
8381SL	✓			
8381SP	✓			
8383C	✓			
8383P	✓			
8515V	✓			
8515Z	✓			
8531	✓			
8532	✓			
8535	✓			
8201T	✓			
8205	✓			
8206	✓			
8207	✓			
8209	✓			
8210	✓			
8216	✓			✓
8220	✓			
8225	✓			
8227	✓			
8228	✓			
8240	✓			
8240F	✓	✓		✓
8242	✓			
8242F	✓	✓		✓
8248	✓			
8249	✓			
8249G	✓			
8250	✓			
8264	✓			
8267	✓			
8272	✓			
8273	✓			
8274	✓			
8274A	✓			
8274G	✓			
8276	✓			
8276G	✓			
8278	✓			
8280	✓			
8282	✓			
8282S	✓			
8284	✓			
8285	✓			
8286	✓			
8287	✓			
8290	✓			
8293	✓			
8297C	✓			
8297F	✓			
8381SX	✓			

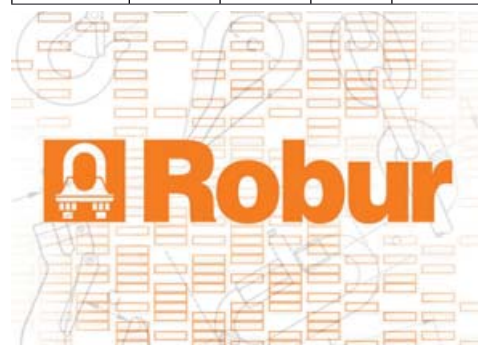



Beta
Collection



È una linea di prodotti esclusivi pensati e realizzati come espressione del carattere Beta che comprende oltre 200 creazioni originali di altissima qualità: attrezzature sportive, abbigliamento tecnico e una molteplicità di oggettistica personalizzata. Ideali per dar vita ad iniziative promozionali, e per trascorrere momenti di svago.



9500TL

softshell in tessuto poliestere 100%, 320g, composto da tre strati, guscio esterno in microfibra, membrana intermedia impermeabile e traspirante, interno in pile



	€		
S	150,00	1	095000051
M	150,00	1	095000052
L	150,00	1	095000053
XL	150,00	1	095000054
XXL	150,00	1	095000055

9501TLD

felpa donna in cotone 80%, poliestere 20%, 320 g



	€		
S	73,00	1	095010061
M	73,00	1	095010062
L	73,00	1	095010063
XL	73,00	1	095010064

9501TL

felpa uomo in cotone 80%, poliestere 20%, 320 g



	€		
S	86,00	1	095010051
M	86,00	1	095010052
L	86,00	1	095010053
XL	86,00	1	095010054
XXL	86,00	1	095010055

9502TL
polo 100% cotone piqué, 210 g



	€		
S	50,00	1	095020051
M	50,00	1	095020052
L	50,00	1	095020053
XL	50,00	1	095020054
XXL	50,00	1	095020055

9505TL
gilet in tessuto esterno 100% poliestere con trattamento idrorepellente, imbottitura 100 gr e tasca interna



	€		
S	125,00	1	095050051
M	125,00	1	095050052
L	125,00	1	095050053
XL	125,00	1	095050054
XXL	125,00	1	095050055

9510
camicia maniche corte in cotone popeline 100%, 110 gr, inserti tessuto arancio e piping bianco, bottone arancio in contrasto, logo reflective e stampa retro.



	€		
XS	69,00	1	095100000
S	69,00	1	095100001
M	69,00	1	095100002
L	69,00	1	095100003
XL	69,00	1	095100004
XXL	69,00	1	095100005

9503TL
T-shirt 100% cotone jersey, 160 g



	€		
S	33,00	1	095030051
M	33,00	1	095030052
L	33,00	1	095030053
XL	33,00	1	095030054
XXL	33,00	1	095030055

9572MB
t-shirt vintage Beta-March F1 100% cotone



	€		
S	52,00	1	095720701
M	52,00	1	095720702
L	52,00	1	095720703
XL	52,00	1	095720704
XXL	52,00	1	095720705

9533N
polo in poliestere traspirante, 175 g, colore nero



	€		
S	30,00	1	095330051
M	30,00	1	095330052
L	30,00	1	095330053
XL	30,00	1	095330054
XXL	30,00	1	095330055

9504TL
giacca in tessuto esterno 100% poliestere con trattamento idrorepellente



	€		
S	102,00	1	095040051
M	102,00	1	095040052
L	102,00	1	095040053
XL	102,00	1	095040054
XXL	102,00	1	095040055

9508TL
giacca impermeabile, 100% poliestere, tascabile



	€		
S	85,00	1	095080051
M	85,00	1	095080052
L	85,00	1	095080053
XL	85,00	1	095080054
XXL	85,00	1	095080055

9534W
polo 3 bottoni in cotone piqué cardato 200 g bianco



	€		
S	33,00	1	095340011
M	33,00	1	095340012
L	33,00	1	095340013
XL	33,00	1	095340014
XXL	33,00	1	095340015

9534B

polo 3 bottoni in cotone piquè cardato 200 g blu



	€		
S	33,00	1	095340051
M	33,00	1	095340052
L	33,00	1	095340053
XL	33,00	1	095340054
XXL	33,00	1	095340055

9537TL

pile 100% poliestere



	€		
S	49,00	1	095370051
M	49,00	1	095370052
L	49,00	1	095370053
XL	49,00	1	095370054
XXL	49,00	1	095370055

9580S

occhiali da sole, modello "Summer"

CE



EN ISO 12312-1:2013+A1:2015
UV400
FILTER CAT. III

	€		
9580S	28,00	1	095800100

9593S

smartwatch, touchscreen, fitness tracker, cinturino in silicone



	€		
9593S	119,00	1	095930200

9593M

orologio con movimento automatico, cassa in acciaio, water resistant 5 ATM, cinturino in acciaio



	€		
9593M	290,00	1	095930120

9593A

cronografo, cassa in acciaio, water resistant 5ATM, cinturino in silicone



	€		
9593A	229,00	1	095930050

9593W

orologio analogico, cassa in plastica soft touch con ghiera in metallo, water resistant 3ATM, cinturino in silicone



	€		
9593W	50,00	1	095930150

9544C

trolley dimensioni formate cabina con 4 ruote doppie, lucchetto TSA, porta USB + jack 3,5 mm



	€		
9544C	119,50	1	095440101

9557J 2.0

borsone in poliestere spalmato/poliestere oxford 600D, dimensioni 47x28x25 cm



	€		
9557J 2.0	71,50	1	095570020

9557J 3.0

borsone in poliestere spalmato/poliestere oxford 600D, dimensioni 58x29x36 cm



	€		
9557J 3.0	87,00	1	095570030

Beta
Quality Tools

Beta

9557N

borsa "Racing" realizzata in tessuto laminato PVC, totalmente impermeabile



cm
80x35x35 € 92,00 1 095570001

9541F

zaino in poliester spalmato/poliester oxford 600D, dimensioni 50x33x16 cm



9541F € 67,00 1 095410011

9541S

zainetto con coulisse in poliester 210D impermeabile cm 33x45



9541S € 9,00 1 095410031

9541BIKE

zainetto in poliester oxford, dimensioni 41x24x16 cm



9541BIKE € 15,80 1 095410021

95740

guanto da lavoro, con polsino elastico elasticizzato, pollice ed indice rinforzati, in pelle sintetica che consente l'uso di dispositivi touchscreen



€ 31,00 1 095740202
M
€ 31,00 1 095740203
L
€ 31,00 1 095740204
XL
€ 31,00 1 095740205
XXL

9574B

guanto da lavoro, con polsino elastico elasticizzato, pollice ed indice rinforzati, in pelle sintetica che consente l'uso di dispositivi touchscreen



€ 31,00 1 095740102
M
€ 31,00 1 095740103
L
€ 31,00 1 095740104
XL
€ 31,00 1 095740105
XXL

9525TL

cappellino Top Line



9525TL € 23,00 1 095250010

9525BB

cappellino bike



9525BB € 23,00 1 095250020

9525F

cappellino con visiera piatta e regolazione in plastica



9525F € 23,00 1 095250099

9525/N

cappellino, 100% cotone, taglia unica regolabile, ricamo diretto sul frontale, sui lati e sul retro, nero



9525N € 13,50 5 095251021

9525/B

cappellino, 100% cotone, taglia unica regolabile, ricamo diretto sul frontale, sui lati e sul retro, bianco



9525B € 13,50 5 095251031

9521

ombrello in nylon T210 con fusto in alluminio, nero, 3 sezioni, automatico



9521 € 25,00 1 095210000

95210B

ombrello in nylon 210T, diametro 100 cm



95210B	€ 28,50	1	095210021
--------	---------	---	-----------

9599CB

city bike Atala®, telaio in alluminio 49 cm, cambio Shimano® 6 velocità, freni V-brake®, cerchi in alluminio 28"



9599CB	€ 478,00	1	095990011
--------	----------	---	-----------

9599CB-W

city bike Atala®, telaio in alluminio, cambio Shimano® 6 velocità, freni V-Brake® cerchi in alluminio 28"



9599CB-W	€ 528,00	1	095990023
----------	----------	---	-----------

9598W

mountain bike Whistle®, telaio in alluminio, forcella Suntour XCT, cambio Shimano Acera 7 velocità (14-28), freni a disco e cerchi 29" in alluminio



9598W M	€ 902,00	1	095980110
9598W L	€ 902,00	1	095980112

9598WHP

mountain bike Whistle®, telaio in alluminio, forcella Suntour XCM con remote lockout, cambio Shimano Deore XT 12 velocità, freni idraulici Shimano e cerchi 29" in alluminio



9598WHP M	€ 1.695,00	1	095980120
9598WHP L	€ 1.695,00	1	095980122

9515M

maglia in tessuto tecnico, traspirante e a rapida asciugatura; inserti laterali in rete



	€	1	
S	65,00	1	095150051
M	65,00	1	095150052
L	65,00	1	095150053
XL	65,00	1	095150054
XXL	65,00	1	095150055
XXXL	65,00	1	095150056

9516B

pantaloncini in Lycra 180 g, traspiranti, a rapida asciugatura, con elastico in vita per una migliore vestibilità



	€	1	
S	75,00	1	095160051
M	75,00	1	095160052
L	75,00	1	095160053
XL	75,00	1	095160054
XXL	75,00	1	095160055
XXXL	75,00	1	095160056

9539CB

casco di protezione per ciclismo su strada e mountain bike con frontino removibile - taglie regolabili



	€	1	
S-M	139,00	1	095390010
L-XL	139,00	1	095390011

9542M

maglia maniche corte in microfibra traspirante, zip lunga coperta, tre tasche posteriori di cui 1 con zip, elastico in silicone a fondo maglia



	€	1	
S	99,50	1	095420051
M	99,50	1	095420052
L	99,50	1	095420053
XL	99,50	1	095420054
XXL	99,50	1	095420055
XXXL	99,50	1	095420056

9542C

salopette in lycra, elastico siliconato fondo gamba, fondello antibatterico ad alta traspirabilità



	€	1	
S	95,00	1	095420061
M	95,00	1	095420062
L	95,00	1	095420063
XL	95,00	1	095420064
XXL	95,00	1	095420065
XXXL	95,00	1	095420066



9542GW

giubbino invernale realizzato in tessuto antivento ad alta traspirabilità e in tessuto garzato; zip lunga, fascia elastica in vita senza silicone; polsino aderente in Lycra; inserti rifrangenti posteriori; 3 tasche esterne posteriori, di cui 1 con zip



	€		
S	172,00	1	095420101
M	172,00	1	095420102
L	172,00	1	095420103
XL	172,00	1	095420104
XXL	172,00	1	095420105
XXXL	172,00	1	095420106

9542G

maglia invernale in tessuto traspirante, garzato internamente, zip lunga, tre tasche posteriori, elastico in silicone a fondo maglia



	€		
S	99,00	1	095420012
M	99,00	1	095420013
L	99,00	1	095420014
XL	99,00	1	095420015
XXL	99,00	1	095420016
XXXL	99,00	1	095420017



9542S

calzamaglia invernale in lycra garzata con fondello antibatterico ad alta traspirabilità



	€		
S	133,00	1	095420022
M	133,00	1	095420023
L	133,00	1	095420024
XL	133,00	1	095420025
XXL	133,00	1	095420026
XXXL	133,00	1	095420027

9542AT

gilet antivento in tessuto accoppiato traspirante, zip lunga



	€		
S	80,00	1	095420072
M	80,00	1	095420073
L	80,00	1	095420074
XL	80,00	1	095420075
XXL	80,00	1	095420076
XXXL	80,00	1	095420077

9542AL

giubbino antivento in tessuto accoppiato traspirante, zip lunga



	€		
S	128,00	1	095420042
M	128,00	1	095420043
L	128,00	1	095420044
XL	128,00	1	095420045
XXL	128,00	1	095420046
XXXL	128,00	1	095420047

9543C

copricollo tubolare, multifunzione, 100% microfibra di poliestere, senza cuciture



	cm	€		
9543C	25x50	7,00	1	095430100

9528B

borraccia in polietilene, 500ml



	€		
9528B	5,50	1	095280005

9597P

pompa a colonna con manometro

• 0÷12 bar



	€		
9597P	47,00	1	095970100



9524SC

garage Beta in miniatura per collezionisti



1:18 € 73,00 1 095240018

9548KB

balance bike, telaio in acciaio e ruota 12" con camera d'aria, età consigliata: + 3 anni, peso massimo < 30 kg



9548KB € 106,00 1 095480110

9547WSK

"Kinder Work Station", banco da lavoro con utensili per bambini a partire da 3 anni



74 cm

9547WSK € 99,00 1 095473801

9547T

"Kinder trolley", carrello attrezzi con utensili per bambini a partire da 3 anni



9547T € 54,00 1 095470100

9548G

"Kinder Garage" a 6 piani, con autolavaggio, ascensore e rampe



69 cm

9548G € 54,00 1 095480100

9561V 2,5

bandiera a vela mt 2,5x0,50 con asta in alluminio basamento a croce completo di zavorra a ciambella



9561V 2,5 € 195,00 1 095610200

9561VV 2,5

bandiera a vela mt 2x0,50 con asta



9561VV 2,5 € 150,00 1 095610201

9561VV

bandiera a vela mt 3,50x0,75 con asta



9561VV € 216,00 1 095610101

9561V

bandiera a vela mt 4x0,75 con asta in metallo cromato basamento in graniglia di cemento 50 cm



9561V € 355,00 1 095610001

9559

striscione monofacciale in TNT, modulo da 3x0,8 m o multipli



9559 € 23,50 1 095591001

9559/30MT

rotolo 10 loghi Beta in TNT



9559/30MT € 220,00 1 095591031

9590B

bandiera in nylon serigrafato



9590B € 99,00 1 095900000





9577M

tuta in T/C twill di poliestere/cotone 65/35, 240 g



Dimensione	Prezzo	Quantità	Articolo
S	118,00	1	095770051
M	118,00	1	095770052
L	118,00	1	095770053
XL	118,00	1	095770054
XXL	118,00	1	095770055
XXXL	118,00	1	095770056

9579C

camice in poliestere/cotone



Dimensione	Prezzo	Quantità	Articolo
M	52,00	1	095791002
L	52,00	1	095791003
XL	52,00	1	095791004

9565BBQ

barbecue in lamiera d'acciaio con griglia e braciere

Dotato di coperchio con morsetto per la chiusura. Griglia in acciaio cromato (conforme alla normativa italiana DM 21.03.73 e regolamento CE 1935/2004 in riferimento all'idoneità del materiale a contatto con gli alimenti), dotata di maniglie e piedini d'appoggio.



Articolo	Prezzo	Quantità	Articolo
9565BBQ	460,00	1	095650100

h 88 cm - ø 59 cm

9565T

tavolo in lamiera d'acciaio con piano in legno multistrato di betulla verniciato.

Fornito con doppio KIT di tubi distanziali (7 o 20 cm) per regolare l'altezza a piacere.



Articolo	Prezzo	Quantità	Articolo
9565T	390,00	1	095650200

h 95→108 cm - ø 70 cm

9565S

seduta in lamiera d'acciaio con sedile in ecopelle sfoderabile



Articolo	Prezzo	Quantità	Articolo
9565S	170,00	2	095650300

h 60 cm - ø 38 cm

9565ICE

portagiaccio in lamiera d'acciaio

Dotato di coperchio di chiusura, con contenitore antigraffio, certificato per uso alimentare. L'interno del fusto è laccato con vernice antiruggine e resistente all'acqua. Nel contenitore si possono collocare ghiaccio e bottiglie/lattine da raffreddare.



Articolo	Prezzo	Quantità	Articolo
9565ICE	180,00	1	095650400

h 60 cm - ø 38 cm

9565K

tavolo 9565T con due sedute 9565S



Articolo	Prezzo	Quantità	Articolo
9565K	730,00	1	095650500

9563G

poltrone per ufficio, per ospiti



Articolo	Prezzo	Quantità	Articolo
9563G	145,00	1	095630050

9563U

poltrona per ufficio, ergonomica, con braccioli



9563U € 285,00 1 095630020

9549BP

batteria portatile, 10000mAh



9549BP € 18,50 1 095490052

9549C

chiavetta USB, 32GB



9549C € 12,50 1 095490062

9547

calcolatrice da tavolo



9547 € 16,50 1 095470000



9594

orologio da parete dotato di termometro ed igrometro, diametro 26 cm



Ø cm 26 € 24,50 1 095940051

9526P

macchina per caffè espresso a capsule

compatibile con cialde Lavazza™, Espresso Point™ per uso professionale



9526P € 279,00 1 095260010

9527 6T

set 6 tazzine caffè



9527 6T € 80,00 1 095270001

9527MUG

tazza "mug" con coperchio e fascia in silicone



9527MUG € 21,00 1 095270020

9522A

apribottiglie con impugnatura ergonomica



9522A € 14,00 1 095220010

9523A

borraccia in alluminio, 500ml



9523A € 9,50 1 095230005

9586K

coltellino multiuso in acciaio, 10 funzioni



9586K € 13,50 1 095860100

9526RMN

set 2 mazzi di 55 carte ramino Modiano®



9526RMN € 23,50 1 095260001

9592B/C50

set 50 penne



9592B/C50 € 40,00 1 095920050



9592B/P

penne personalizzate



9592B/P € 1,20 500 095920051

9592MB

penna a sfera Parker®



9592MB € 65,00 1 095920060

9592M/50

set 50 matite



9592M/50 € 40,00 1 095920100

9588M

termoformato morbido con 1 penna e 2 block notes



9588M € 17,20 1 095880011

9596

portabadge in poliestere con moschettone in metallo e filo portatelefono



9596 € 4,00 10 095961001



9595C

portachiave in pelle



9595C € 7,30 1 095950011

9595T

portachiave in metallo cromato, in bustina di velluto



9595T € 6,10 1 095950021

9595 C25

portachiave in metallo cromato con gancio in gomma



9595 C25 € 7,60 1 095950031

9569P

shopper in polietilene, con soffiati laterali



9569P 44x34 € 0,65 50 095691001

9569S

shopper in TNT con soffietto, 38x42 cm



9569S cm 38x42 € 2,00 50 095690051

9569MS-2

shopper in polipropilene, ad alta resistenza



9569MS-2 cm 45x40 € 5,30 5 095690055

9569MS

shopper in polipropilene, ad alta resistenza, con doppi manici



9569MS cm 60x40 € 5,30 5 095690052

9587 9x14

taccuino, 9x14 cm



9587 9X14 € 10,80 5 095870009



9587 13x21

taccuino, 13x21 cm



9587 13X21 € 13,90 5 095870013

9588S/10...

set di 10 block notes



9588S/10A	€ 23,50	1	095881001
21x29 cm			
9588S/10B	€ 22,50	1	095881002
15x21 cm			
9588S/10C	€ 14,40	1	095881003
10x15 cm			
9588S/10D	€ 10,40	1	095880054
7,5x10,5 cm			

9588/10PI

set di 10 blocchetti per appunti con fogli adesivi



9588S/10PI € 22,00 1 095880055
7,5x7,5 cm

9589A/36

confezione da 36 rotoli di nastro adesivo per imballo, logo Beta, avana



9589A/36 € 112,00 1 095890035

9589B/36

confezione da 36 rotoli di nastro adesivo per imballo, logo Beta, bianco



9589B/36 € 112,00 1 095890036

9562TB

tappeto prova calzature, con retro gommato antiscivolo



9562TB € 38,50 1 095620500

9562T2

tappeto per banco da lavoro 200x160 cm

- protegge il suolo da perdite d'olio, benzina e rispetta l'ambiente
- facile da pulire, fondo gommato ed antiscivolo



9562T2 € 192,00 1 095620200



9562T3

tappeto da officina 300x160 cm

- particolarmente indicato per l'utilizzo sotto ponti sollevatori moto
- protegge il suolo da perdite d'olio, benzina e rispetta l'ambiente
- facile da pulire, fondo gommato ed antiscivolo



9562T3 € 279,00 1 095620300

9562P2

tappeto con logo BETA 200x80 cm

- particolarmente indicato per utilizzi con arredo officina C55, C45 o come tappeto sottomoto
- protegge il suolo da perdite d'olio, benzina e rispetta l'ambiente
- facile da pulire, fondo gommato ed antiscivolo



9562P2 € 135,00 1 095620400

9562P12

rotolo tappeto multi logo 12 m x 80 cm

- permette di personalizzare la lunghezza del tappeto in base alle esigenze dell'utilizzatore
- protegge il suolo da perdite d'olio, benzina e rispetta l'ambiente
- facile da pulire, fondo gommato ed antiscivolo



9562P12 € 680,00 1 095620425

CAMPI DI IMPIEGO CHIAVI DINAMOMETRICHE

1 Nm = 0,10197 Kgfm = 0,7375 lbf.ft



Dimensione	Modello	Immagine	Min. (Nm)	Max. (Nm)	Min. (Kgfm)	Max. (Kgfm)	Min. (lbf.ft)	Max. (lbf.ft)
1/4"	590		0,3	4				
	590/1		0,5	13,5				
	603/5		1	5				
	603/10		2	10				
	605E/5		1	5				
	605E/10		2	10				
	666N/2			5	25			
3/8"	592/3		1	27				
	592/4		3	40				
	599DGT/6			12	60			
	665/6			10	60			
	665/10			20	100			
	665LB/6			7 LBF.FT	45 LBF.FT			
	665LB/10			15 LBF.FT	75 LBF.FT			
	666N/2X		5	25				
	666N/5			10	50			
	666N/10			20	100			
	666N LBF.IN/5			90 LBF.IN	440 LBF.IN			
	666N LBF.IN/10			200 LBF.IN	800 LBF.IN			
	668RGC/6			12	60			
	668RGC/10			20	100			
	1/2"	594/8		6	80			
594/21				20	215			
599DGT/10X				20	100			
599DGT/20				40	200			
599DGT/30				68	340			
599DGT-AN/10				20	100			
599DGT-AN/20				40	200			
606MQ/50			5	50				
665/10X				20	100			
665/20				40	200			
665/30				60	330			
665LB/10X				15 LBF.FT	75 LBF.FT			
665LB/20				30 LBF.FT	150 LBF.FT			
665LB/30				45 LBF.FT	240 LBF.FT			
666N/10X				20	100			
666N/20				40	200			
666N/30				60	300			
666N LBF.IN/10X				200 LBF.IN	800 LBF.IN			
666N LBF.IN/20				400 LBF.IN	1800 LBF.IN			
666N LBF.IN/30				500 LBF.IN	3000 LBF.IN			
667N/20				40	200			
667N/30				60	300			
668RGC/10X				20	100			
668RGC/20			40	200				



SERVIZIO DI TARATURA DINAMOMETRIA

Beta Utensili SpA dispone di attrezzature certificate **Accredia (LAT)** per la taratura di chiavi dinamometriche fino a 2000 Nm, in conformità alla norma **UNI EN ISO 6789:2017**.

Presso il Laboratorio Beta è possibile eseguire la calibrazione dei seguenti articoli:



Chiavi a slittamento, a disinnesto o scatto



Chiavi non graduate



Chiavi a lettura



Chiavi digitali



Giravite dinamometrici



Dynatester

Per alcune chiavi dinamometriche è possibile richiedere la certificazione destrorsa, sinistrorsa o entrambe. La norma prevede un controllo su tre punti con cinque campionamenti.

Per le chiavi pretarate è previsto un solo punto di controllo (richiesto dal cliente) con cinque campionamenti.

I Dynatester vengono certificati presso un laboratorio esterno accreditato UKAS, riconosciuto a livello internazionale.

Oltre al normale certificato di calibrazione, è possibile anche richiedere un certificato primario rilasciato direttamente da un laboratorio esterno accreditato (LAT Accredia).

La validità dei certificati è pari a 5.000 cicli o a un anno dal primo utilizzo, secondo quanto previsto dalla norma UNI EN ISO 6789.

Beta Utensili S.p.A.
Via Volta 18 - 20845 Sovico (MB) Italy
Tel +39 039 20.77.1 - Fax. +39 039 20.10.742
www.beta-tools.com - e-mail info@beta-

Beta

CERTIFICATE OF CALIBRATION

L'utensile dinamometrico identificato in questo documento è conforme alla norma **ISO 6789-2:2017**
The torque tool identified in this document is declared to be in conformance with: ISO 6789-2:2017

Modello: **666N/2** Serie: **79108288478**
Model: Serial number:

Campo di applicazione: **5.0 + 25.0 N·m**
Torque range:

Temperatura: **20.0°C** Umidità relativa: **< 90%**
Temperature: Relative humidity:

I valori osservati rientrano nel **±3%** del valore di misura dichiarato dal costruttore.
The observed values fall within the maximum ±3% measurement error claimed by the manufacturer.

Valore impostato Set Torque N·m	Valori riscontrati Observed Value Senso orario Clockwise direction N·m					Valore medio Mean Value N·m	Incertezza relativa Relative Expanded Uncertainty (k=2)	Intervallo incertezza Relative Uncertainty Interval (k=2)
5.0	5.055	5.010	4.993	5.017	4.973	5.010	2.95%	3.24%
15.0	15.006	14.958	14.936	14.975	14.906	14.956	1.01%	3.24%
25.0	25.190	25.141	25.166	25.132	25.119	25.150	0.61%	1.31%

La strumentazione utilizzata per la calibrazione ha una rintracciabilità internazionale attraverso il seguente laboratorio di calibrazione che è accreditato secondo la ISO 17025:2005.
The test equipment used in the performance of the above calibration has international traceability through the following calibration laboratory which is UKAS accredited to ISO 17025:2005

Modello Tester: **FMT 60** Serie: **107078**
Tester Model: Serial Number:

Certificato n°: **226343** UKAS Laboratorio n°: **0256**
Cert No.: UKAS Laboratory No.:

La strumentazione ha un errore relativo di max 0,10% e un intervallo di incertezza relativa di 0,28%. Il massimo errore relativo misurato è inferiore a 1/4 della massima deviazione permessa sull'utensile.
The torque measurement device has a maximum relative error of 0.10% and a relative measurement uncertainty interval of 0.28%. The maximum relative error is therefore less than 1/4 of the maximum permissible relative deviation of the torque tool.

Data: **16 April 2018** Responsabile: **F.Sacchet**
Date: Responsible Person:

Per usufruire di questo servizio rivolgiti al tuo rivenditore di fiducia

ARTICOLI ELIMINATI - ARTICOLI SOSTITUTIVI/CONSIGLIATI

	ARTICOLO ELIMINATO
	ARTICOLO SOSTITUTIVO
	ARTICOLO CONSIGLIATO

42/B9	000420064	42/B9	000421064
42/S17	000420065	42/S17	000421065
42/S15	000420066	42/S15	000421066
42/S14	000420067	42/S14	000421067
42/S17X	000420068	42/S17X	000421068
42/S26	000420070	42/S26	000421070
42/SP15	000420078	42/SP15	000421078
42/SP25	000420085	42/SP25	000421085
42/SC9I	000420087	42/SC9I	000421087
42/SC9E	000420088	42/SC9E	000421088
42HS 6	000424006	42HS 6	000424506
42HS 7	000424007	42HS 7	000424507
42HS 8	000424008	42HS 8	000424508
42HS 9	000424009	42HS 9	000424509
42HS 10	000424010	42HS 10	000424510
42HS 11	000424011	42HS 11	000424511
42HS 12	000424012	42HS 12	000424512
42HS 13	000424013	42HS 13	000424513
42HS 14	000424014	42HS 14	000424514
42HS 15	000424015	42HS 15	000424515
42HS 16	000424016	42HS 16	000424516
42HS 17	000424017	42HS 17	000424517
42HS 18	000424018	42HS 18	000424518
42HS 19	000424019	42HS 19	000424519
42HS 20	000424020	42HS 20	000424520
42HS 21	000424021	42HS 21	000424521
42HS 22	000424022	42HS 22	000424522
42HS 23	000424023	42HS 23	000424523
42HS 24	000424024	42HS 24	000424524
42HS 25	000424025	42HS 25	000424525
42HS 26	000424026	42HS 26	000424526
42HS 27	000424027	42HS 27	000424527
42HS 28	000424028	42HS 28	000424528
42HS 29	000424029	42HS 29	000424529
42HS 30	000424030	42HS 30	000424530
42HS 32	000424032	42HS 32	000424532
42HS 34	000424034	42HS 34	000424534
42HS 36	000424036	42HS 36	000424536
42K 5,5	000429005	42K 5,5	000429505
42K 6	000429006	42K 6	000429506
42K 7	000429007	42K 7	000429507
42K 8	000429008	42K 8	000429508
42K 9	000429009	42K 9	000429509
42K 10	000429010	42K 10	000429510
42K 11	000429011	42K 11	000429511
42K 12	000429012	42K 12	000429512
42K 13	000429013	42K 13	000429513
42K 14	000429014	42K 14	000429514
42K 15	000429015	42K 15	000429515
42K 16	000429016	42K 16	000429516
42K 17	000429017	42K 17	000429517
42K 18	000429018	42K 18	000429518
42K 19	000429019	42K 19	000429519
42K 20	000429020	42K 20	000429520
42K 21	000429021	42K 21	000429521
42K 22	000429022	42K 22	000429522
42K 23	000429023	42K 23	000429523
42K 24	000429024	42K 24	000429524
42K 25	000429025	42K 25	000429525
42K 26	000429026	42K 26	000429526
42K 27	000429027	42K 27	000429527
42K 28	000429028	42K 28	000429528
42K 29	000429029	42K 29	000429529
42K 30	000429030	42K 30	000429530
42K 32	000429032	42K 32	000429532
606MQ/25	006060702	606MQ/50	006060705
961D	009610500	961P6	009610000
961D/CF 3,8	009610511		
961D/DC 8,5	009610513		
961D/DC 5,5	009610517		
1084 140	010840004	1084 160	010840006
1084 180	010840008	1084 200	010840010
1084BM 140	010840034	1084BM 160	010840036

1084BM 180	010840038	1084BM 200	010840040
1150 160	011500006	1150 160	011500046
1150 180	011500008	1150 180	011500048
1150 200	011500010	1150 200	011500050
1150 220	011500012	1150 220	011500052
1150BM 160	011500036	1150BM 160	011500146
1150BM 180	011500038	1150BM 180	011500148
1150BM 200	011500040	1150BM 200	011500150
1150BM 220	011500042	1150BM 220	011500152
1150BM-HS 160	011504036	1150BM-HS 160	011504146
1150BM-HS 180	011504038	1150BM-HS 180	011504148
1150BM-HS 200	011504040	1150BM-HS 200	011504150
1150K 160	011509006	1150K 160	011509046
1150K 180	011509008	1150K 180	011509048
1150K 200	011509010	1150K 200	011509050
1150K 220	011509012	1150K 220	011509052
1150BMK 160	011509036	1150BMK 160	011509146
1150BMK 180	011509038	1150BMK 180	011509148
1150BMK 200	011509040	1150BMK 200	011509150
1150BMK 220	011509042	1150BMK 220	011509152
1201 2,5X50	012010003	1201E 2,5X50	012011003
1201 2,5X75	012010006	1201E 2,5X75	012011006
1201 3X75	012010009	1201E 3X75	012011009
1201 3X100	012010012	1201E 3X100	012011012
1201 3,5X75	012010018	1201E 3,5X75	012011018
1201 3,5X100	012010021	1201E 3,5X100	012011021
1201 4X100	012010030	1201E 4X100	012011030
1201 4X125	012010033	1201E 4X125	012011033
1201 4X150	012010036	1201E 4X150	012011036
1201 5,5X100	012010039	1201E 5,5X100	012011039
1201 5,5X125	012010040	1201E 5,5X125	012011040
1201 5,5X150	012010042	1201E 5,5X150	012011042
1201 6,5X100	012010048	1201E 6,5X100	012011048
1201 6,5X125	012010050	1201E 6,5X125	012011050
1201 6,5X150	012010051	1201E 6,5X150	012011051
1201 8X150	012010057	1201E 8X150	012011057
1201 8X200	012010060	1201E 8X200	012011060
1201 10X200	012010066	1201E 10X200	012011066
1201N 4X30	012010103	1201EN 4X30	012011103
1201N 6,5X30	012010106	1201EN 6,5X30	012011106
1201/S6	012010206	1201E/S6	012011206
1201DZ	012010501	1201E/DZ	012011501
1201K 2,5X50	012019003	1201E/K 2,5X50	012019203
1201K 2,5X75	012019006	1201E/K 2,5X75	012019206
1201K 3X75	012019009	1201E/K 3X75	012019209
1201K 3X100	012019012	1201E/K 3X100	012019212
1201K 3,5X75	012019018	1201E/K 3,5X75	012019218
1201K 3,5X100	012019021	1201E/K 3,5X100	012019221
1201K 4X100	012019030	1201E/K 4X100	012019230
1201K 4X125	012019033	1201E/K 4X125	012019233
1201K 4X150	012019036	1201E/K 4X150	012019236
1201K 5,5X100	012019039	1201E/K 5,5X100	012019239
1201K 5,5X125	012019040	1201E/K 5,5X125	012019240
1201K 5,5X150	012019042	1201E/K 5,5X150	012019242
1201K 6,5X100	012019048	1201E/K 6,5X100	012019248
1201K 6,5X125	012019050	1201E/K 6,5X125	012019250
1201K 6,5X150	012019051	1201E/K 6,5X150	012019251
1201K 8X150	012019057	1201E/K 8X150	012019257
1201K 8X200	012019060	1201E/K 8X200	012019260
1201K 10X200	012019066	1201E/K 10X200	012019266
1201NK 4X30	012019103	1201ENK 4X30	012019303
1201NK 6,5X30	012019106	1201ENK 6,5X30	012019306
1202 3X60	012020003	1202E 3X60	012021003
1202 3X100	012020006	1202E 3X100	012021006
1202 4,5X80	012020009	1202E 4,5X80	012021009
1202 4,5X120	012020012	1202E 4,5X120	012021012
1202 6X100	012020018	1202E 6X100	012021018
1202 6X150	012020021	1202E 6X150	012021021
1202 8X150	012020024	1202E 8X150	012021024
1202 9,5X200	012020027	1202E 9,5X200	012021027
1202N 4,5X30	012020103	1202EN 4,5X30	012021103
1202N 6X30	012020106	1202EN 6X30	012021106
1202/S4	012020204	1202E/S4	012021204
1202L 3X300	012020303	1202EL 3X300	012021303
1202L 4,5X300	012020305	1202EL 4,5X300	012021305
1202L 4,5X400	012020306	1202EL 4,5X400	012021306
1202L 6X400	012020309	1202EL 6X400	012021309
1202K 3X60	012029003	1202E/K 3X60	012029203
1202K 3X100	012029006	1202E/K 3X100	012029206

1202K 4,5X80	012029009	1202E/K 4,5X80	012029209
1202K 4,5X120	012029012	1202E/K 4,5X120	012029212
1202K 6X100	012029018	1202E/K 6X100	012029218
1202K 6X150	012029021	1202E/K 6X150	012029221
1202K 8X150	012029024	1202E/K 8X150	012029224
1202K 9,5X200	012029027	1202E/K 9,5X200	012029227
1202NK 4,5X30	012029103	1202ENK 4,5X30	012029303
1202NK 6X30	012029106	1202ENK 6X30	012029306
1203/D5	012030001	1203E/D5	012031001
1203/D5PZ	012030003	1203E/D5PZ	012031003
1203/D6	012030006	1203E/D6	012031006
1203/D7	012030007	1203E/D7	012031007
1203/D8	012030008	1203E/D8	012031008
1203/S8	012030009	1203E/S8	012031009
1203/D10	012030010	1203E/D10	012031010
1203/D10N	012030019	1203E/D10N	012031019
1203/S10	012030021	1203E/S10	012031021
1203/E1P	012030301	1203E/E1P	012031301
1203/E4P	012030304	1203E/E4P	012031304
1203/E5P	012030305	1203E/E5P	012031305
1203/E10P	012030310	1203E/E10P	012031310
1203/EV1P	012030351	1203E/EV1P	012031351
1203/EV4P	012030354	1203E/EV4P	012031354
1203/EV5P	012030355	1203E/EV5P	012031355
1203/EV10P	012030360	1203E/EV10P	012031360
1204 2,5X60	012040003	1204E 2,5X60	012041003
1204 3X75	012040006	1204E 3X75	012041006
1204 3X100	012040009	1204E 3X100	012041009
1204 4X100	012040012	1204E 4X100	012041012
1204 4X125	012040015	1204E 4X125	012041015
1204 5X125	012040018	1204E 5X125	012041018
1204 5X150	012040021	1204E 5X150	012041021
1204 6,5X150	012040024	1204E 6,5X150	012041024
1204/S5	012040205	1204E/S5	012041205
1204L 2,5X200	012040303	1204EL 2,5X200	012041303
1204L 3X300	012040306	1204EL 3X300	012041306
1204L 4X400	012040309	1204EL 4X400	012041309
1204L 5X400	012040315	1204EL 5X400	012041315
1204L 6,5X400	012040318	1204EL 6,5X400	012041318
1204K 2,5X60	012049003	1204E/K 2,5X60	012049103
1204K 3X75	012049006	1204E/K 3X75	012049106
1204K 3X100	012049009	1204E/K 3X100	012049109
1204K 4X100	012049012	1204E/K 4X100	012049112
1204K 4X125	012049015	1204E/K 4X125	012049115
1204K 5X125	012049018	1204E/K 5X125	012049118
1204K 5X150	012049021	1204E/K 5X150	012049121
1204K 6,5X150	012049024	1204E/K 6,5X150	012049124

ARTICOLI ELIMINATI - ARTICOLI SOSTITUTIVI/CONSIGLIATI

	ARTICOLO ELIMINATO
	ARTICOLO SOSTITUTIVO
	ARTICOLO CONSIGLIATO

1207TXK 27	012079027	1207E TX/K27	012079127
1207TXK 30	012079030	1207E TX/K30	012079130
1207TXK 40	012079040	1207E TX/K40	012079140
1207TXK 45	012079045	1207E TX/K45	012079145
1208RTX 09	012080009	1208E/RTX 09	012081009
1208RTX 10	012080010	1208E/RTX 10	012081010
1208RTX 15	012080015	1208E/RTX 15	012081015
1208RTX 20	012080020	1208E/RTX 20	012081020
1208RTX 25	012080025	1208E/RTX 25	012081025
1208RTX 27	012080027	1208E/RTX 27	012081027
1208RTX 30	012080030	1208E/RTX 30	012081030
1208RTX 40	012080040	1208E/RTX 40	012081040
1208RTX/D7	012080207	1208E/RTX-D7	012081207
1208RTXK 09	012089009	1208E RTX/K09	012089109
1208RTXK 10	012089010	1208E RTX/K10	012089110
1208RTXK 15	012089015	1208E RTX/K15	012089115
1208RTXK 20	012089020	1208E RTX/K20	012089120
1208RTXK 25	012089025	1208E RTX/K25	012089125
1208RTXK 27	012089027	1208E RTX/K27	012089127
1208RTXK 30	012089030	1208E RTX/K30	012089130
1208RTXK 40	012089040	1208E RTX/K40	012089140
1209PZ 0	012090000	1209E/PZ 0	012091000
1209PZ 1	012090003	1209E/PZ 1	012091003
1209PZ 2	012090006	1209E/PZ 2	012091006
1209PZ 3	012090009	1209E/PZ 3	012091009
1209PZ 4	012090012	1209E/PZ 4	012091012
1209N/PZ 1	012090103	1209EN/PZ 1	012091103
1209N/PZ 2	012090106	1209EN/PZ 2	012091106
1209PZ/S4	012090204	1209E/PZ-S4	012091204
1209PZK 0	012099000	1209E PZ/K0	012099200
1209PZK 1	012099003	1209E PZ/K1	012099203
1209PZK 2	012099006	1209E PZ/K2	012099206
1209PZK 3	012099009	1209E PZ/K3	012099209
1209PZK 4	012099012	1209E PZ/K4	012099212
1209N/PZK 1	012099103	1209EN-PZ/K1	012099303
1209N/PZK 2	012099106	1209EN-PZ/K2	012099306
1367/S6	013670100	1367/K10	013670200
1367 17	013670117		
1367 18	013670118		
1367 19	013670119		
1367 20	013670120		
1367 21	013670121		
1367 22	013670122		
1367 23	013670123		
1367 24	013670124		
1367 27	013670127		
1367 28	013670128		
1438K/DSG	014380250		
1467LF	014670100	1467LF/2	014670099
1482A/2	014820006		
1482A/4	014820014		
1485MT/J.1.3	014850160		
1493 96-L9	014930070		
1498CM/12	014980030		
1533/5	015330005	1533/5A	015330006
1534/5	015340005	1534/5A	015340006
1535/C5	015350005	1535/C5A	015350006
1548/C8	015480800		
1604	016040001		
1604/C9	016040045		
1605	016050001		
1606	016060001	1606/2	016060002
1778W	017780025		
1834L/USB	018340075	1833 L/USB	018330054
1834PS	018340310	1833 S	018330002
1834PM	018340320	1833 M	018330003
1834PL	018340325	1833 L	018330004
1834PXL	018340330	1833 XL	018330005
1834RB-L/USB	018340975		
1835/1	018350030	1833 XS/1	018330000
1835/2	018350060	1833 XS/2	018330001
1837N	018370002	1837F	018370050
1837PLUS	018370026	1837C/4300	018370430

1837/USB	018370051	1837F/USB	018370060
1837/USB RB	018370901		
1838SN	018380132	1838S	018380122
1838SLR	018380201	1838SLIM	018380221
1839/R3	018390503		
1916R 6	019160106		
1916R 8	019160108		
1916R 11	019160111		
1918 8	019180008	1918 1/4X8	019180118
1918 10	019180010	1918 3/8X10	019180130
1918 12	019180012	1918 1/2X12	019180142
1972/18	019720018		
1982/12EF	019820012		
2001/B26	020010060	2001/B26	020010215
2009ID	020090013	2009ID	020091013
2028EL/A	020280014	2028EL/A	020281014
2028ET/A	020280018	2028ET/A	020281018
2029EL/B	020290017	2029EL/B	020291017
2029ET/B	020290021	2029ET/B	020291021
2029 BG MQ	020290257	2029 BG MQ	020291257
2032TEL/A	020320314	2032TEL/A	020321314
2032TET/A	020320328	2032TET/A	020321328
2033PEL/A	020330214	2033PEL/A	020331214
2033PEL/B	020330215	2033PEL/B	020331215
2033PET/B	020330227	2033PET/B	020331227
2036EL/B	020360218	2036EL/B	020361218
2036TET/B	020360223	2036TET/B	020361223
2041UC	020410210	2041UC	020410215
2051N	020510210	2051N	020510215
2104VU/0	021040122	2104VU/0	021041122
2055HB	020550220	2055HB	020550215
2105VU/0	021050122	2105VU/0	021051122
2106T/VU0	021060123	2106T/VU0	021061123
2107VU/2	021070112	2107VU/2	021071112
2107VU/3	021070114	2107VU/3	021071114
2108VU/1	021080022	2108VU/1	021081022
2109VU/1	021090022	2109VU/1	021091022
2109VU/3	021090024	2109VU/3	021091024
2110VU/1	021100031	2110VU/1	021101031
2110VU/3	021100034	2110VU/3	021101034
2110VU/AS	021100036	2110VU/AS	021101036
2110SVU/1	021100041	2110SVU/1	021101041
2110SVU/3	021100044	2110SVU/3	021101044
2111VU/1	021110031	2111VU/1	021111031
2111VU/3	021110034	2111VU/3	021111034
2112ET/A	021120028	2112ET/A	021121028
2112ET/B	021120029	2112ET/B	021121029
2112VU/5	021120056	2112VU/5	021121056
2114VU/M	021140011	2114VU/M	021141011
2115PVU/1	021150232	2115PVU/1	021151232
2115PVU/2	021150234	2115PVU/2	021151234
2115PL-VU/1	021150242	2115PL-VU/1	021151242
2115PL-VU/3	021150245	2115PL-VU/3	021151245
2116VU/1	021160102	2116VU/1	021161102
2116VU/3	021160105	2116VU/3	021161105
2117P-VU/1	021170042	2117P-VU/1	021171042
2117P-VU/3	021170045	2117P-VU/3	021171045
2117L-VU/1	021170142	2117L-VU/1	021171142
2117PL-VU/3	021170145	2117PL-VU/3	021171145
2118VU/1	021180032	2118VU/1	021181032
2119VU/3	021190025	2119VU/3	021191025
2119L-VU/3	021190125	2119L-VU/3	021191125
2120VU/2	021200061	2120VU/2	021201061
2120VU/3	021200063	2120VU/3	021201063
2120VU/4	021200064	2120VU/4	021201064
2120VU/AS	021200068	2120VU/AS	021201068
2120L-VU/2	021200161	2120L-VU/2	021201161
2120L-VU/3	021200163	2120L-VU/3	021201163
2120L-VU/4	021200164	2120L-VU/4	021201164
2120L-VU/AS	021200168	2120L-VU/AS	021201168
2254SV	022540100	2254K	022540101
T10	024240010	T01	024240001
T15	024240015	T05	024240005
T16	024240016	T06	024240006
T131	024240131	T137	024240137
T132	024240132	T138	024240138
T142	024240142	T144	024240144
T154	024240154	T156	024240156
T155	024240155	T157	024240157

T210	024240210	T211	024240211
T212	024240212	T213	024240213
T215	024240215	T216	024240216
T220	024240220	T221	024240221
M10	024500010	M01	024500001
M15	024500015	M05	024500005
M16	024500016	M06	024500006
M130	024500130	M129	024500129
M131	024500131	M136	024500136
M132	024500132	M137	024500137
M210	024500210	M213	024500213
M211	024500211	M214	024500214
M212	024500212	M216	024500216
M215	024500215	M217	024500217
M220	024500220	M218	024500218
M221	024500221	M219	024500219
M25	024500873	M25	024500025
M165	024500874	M166	024500879
MB11	024504211	MB12	024504212
MB34	024504234	MB37	024504237
MB35	024504235	MB38	024504238
MB36	024504236	MB39	024504239
MB57	024504257		
MB61	024504261	MB65	024504265
MM10	024580010	MM11	024580011
MM140	024580140	MM140	024580141
MM210	024580210	MM210	024580211
MC10	027500010	MC10	027500011
MC11	041500011	MC12	041500012
C42S	042000001	C42H	042000002
C55LMP/1	055000320		
C55LMP/2	055000322		
5902MT	059020053	5902MT	059021053
5902MT/AS	059020054	5902MT/AS	059021054
5902VI	059020060	5902VI	059021060
5904VG/3	059040062	5904VG/3	059041062
5904VU/2T	059040070	5904VU/2T	059041070
5904VI/1T	059040161	5904VI/1T	059041161
5904VI/2T	059040164	5904VI/2T	059041164
5904VI/3T	059040168	5904VI/3T	059041168
5904VG/2T	059040191	5904VG/2T	059041191
5904VG/5T	059040196	5904VG/5T	059041196
5904VG/1M	059040197	5904VG/2M	059041198
5904VG/2M	059040198	5904VU/1M	059041201
5904VU/1M	059040201	5904VU/2M	059041202
5904VU/2M	059040202	5904VU/3T	059041203
5904VU/3T	059040203	5904VG/3T	059041510
5904VG/3T	059040510		
5905VG/2	059050044	5905VG/2	059051044
5905VG/1	059050058	5905VG/1	059051058
5908VG/2T	059080017	5908VG/2T	059081017
5908VI/2T	059080105	5908VI/2T	059081105
5910VI/3	059100044	5910VI/3	059101044
5910VI/3T	059100063	5910VI/3T	059101063
5910VG/3T	059100068	5910VG/3T	059101068
5914VU/M	059140111	5914VU/M	059140112
5915VU/0	059150021	5915VU/0	059151021
5915VU/1	059150024	5915VU/1	059151024
5915VU/2	059150027	5915VU/2	059151027
5915VU/3	059150028	5915VU/3	059151028
5915VU/AS	059150032	5915VU/AS	059151032
5915VU/4	059150045	5915VU/4	059151045
5915VU/5	059150046	5915VU/5	059151046
5927VU/M	059270021	5927VU/M	059271021
5935VU/1MB	059350301		
5935VI/1MB	059350311		
5935VI/2MB	059350316	5935VI/2MB	059351316
5935VG/1MB	059350321	5935VG/1MB	059351321
5935ET/1MB	059350332	5935ET/1MB	059351332
5938U/2T	059380062	5938U/2T	059381062
5940SBK	059400082	5940SBK	059401082
5941VU/M	059410002	5941V	

ARTICOLI ELIMINATI - ARTICOLI SOSTITUTIVI/CONSIGLIATI

	ARTICOLO ELIMINATO
	ARTICOLO SOSTITUTIVO
	ARTICOLO CONSIGLIATO

5958U	059580008	5958U	059581008
5980U/BIKE	059800040	5980U/BIKE	059801040
5980EL/A	059800081	5980EL/A	059801081
5980EL/B	059800082	5980EL/B	059801082
5980ET/A	059800083	5980ET/A	059801083
5980ET/B	059800084	5980ET/B	059801084
5980ID	059800085	5980ID	059801085
5980MQ	059800257	5980MQ	059801257
5988ROAD/7M	059880087	5988H/7M	059881087
5988U6/M	059880430	5988U6/M	059881430
6600 M/11	066000011		
6600 M/216	066000216		
6600 M/221	066000221		
6600 M/244	066000244		
6600 M/370	066000370		
6600 M/422	066000422		
6600 M/608	066000608		
6600 M/851	066000851		
6600 M/858	066000858		
6600 M/859	066000859		
6600 E/A20	066000913		
6600 E/A30	066000924		
6600 E/C10	066000928		
6600 E/B10	066000971		
6600 E/B20	066000972		
6600 E/A10	066000973		
6600 E/K20	066000982		
7210PB 35	072100435	7224PEK 35	072240235
7210PB 36	072100436	7224PEK 36	072240236
7210PB 37	072100437	7224PEK 37	072240237
7210PB 38	072100438	7224PEK 38	072240238
7210PB 39	072100439	7224PEK 39	072240239
7210PB 40	072100440	7224PEK 40	072240240
7210PB 41	072100441	7224PEK 41	072240241
7210PB 42	072100442	7224PEK 42	072240242
7210PB 43	072100443	7224PEK 43	072240243
7210PB 44	072100444	7224PEK 44	072240244
7210PB 45	072100445	7224PEK 45	072240245
7210PB 46	072100446	7224PEK 46	072240246
7210PB 47	072100447	7224PEK 47	072240247
7210PB 48	072100448	7224PEK 48	072240248
7211PG 35	072110435	7317NA 35	073170135
7211PG 36	072110436	7317NA 36	073170136
7211PG 37	072110437	7317NA 37	073170137
7211PG 38	072110438	7317NA 38	073170138
7211PG 39	072110439	7317NA 39	073170139
7211PG 40	072110440	7317NA 40	073170140
7211PG 41	072110441	7317NA 41	073170141
7211PG 42	072110442	7317NA 42	073170142
7211PG 43	072110443	7317NA 43	073170143
7211PG 44	072110444	7317NA 44	073170144
7211PG 45	072110445	7317NA 45	073170145
7211PG 46	072110446	7317NA 46	073170146
7211PG 47	072110447	7317NA 47	073170147
7211PG 48	072110448	7317NA 48	073170148
7237WR 35	072370235	7238WR 35	072380235
7237WR 36	072370236	7238WR 36	072380236
7237WR 37	072370237	7238WR 37	072380237
7237WR 38	072370238	7238WR 38	072380238
7237WR 39	072370239	7238WR 39	072380239
7237WR 40	072370240	7238WR 40	072380240
7237WR 41	072370241	7238WR 41	072380241
7237WR 42	072370242	7238WR 42	072380242
7237WR 43	072370243	7238WR 43	072380243
7237WR 44	072370244	7238WR 44	072380244
7237WR 45	072370245	7238WR 45	072380245
7237WR 46	072370246	7238WR 46	072380246
7237WR 47	072370247	7238WR 47	072380247
7237WR 48	072370248	7238WR 48	072380248
7239C 35	072390235		
7239C 36	072390236		
7239C 37	072390237		
7239C 38	072390238		

7239C 39	072390239		
7239C 40	072390240		
7239C 41	072390241		
7239C 42	072390242		
7239C 43	072390243		
7239C 44	072390244		
7239C 45	072390245		
7239C 46	072390246		
7239C 47	072390247		
7239C 48	072390248		
7241FT 35	072410635	7243FT 35	072430635
7241FT 36	072410636	7243FT 36	072430636
7241FT 37	072410637	7243FT 37	072430637
7241FT 38	072410638	7243FT 38	072430638
7241FT 39	072410639	7243FT 39	072430639
7241FT 40	072410640	7243FT 40	072430640
7241FT 41	072410641	7243FT 41	072430641
7241FT 42	072410642	7243FT 42	072430642
7241FT 43	072410643	7243FT 43	072430643
7241FT 44	072410644	7243FT 44	072430644
7241FT 45	072410645	7243FT 45	072430645
7241FT 46	072410646	7243FT 46	072430646
7241FT 47	072410647	7243FT 47	072430647
7241FT 48	072410648	7243FT 48	072430648
7290NA 36	072900336		
7290NA 37	072900337		
7290NA 38	072900338		
7290NA 39	072900339		
7290NA 40	072900340		
7290NA 41	072900341		
7290NA 42	072900342		
7290NA 43	072900343		
7290NA 44	072900344		
7290NA 45	072900345		
7290NA 46	072900346		
7290NA 47	072900347		
7290NA 48	072900348		
7291NA 36	072910336		
7291NA 37	072910337		
7291NA 38	072910338		
7291NA 39	072910339		
7291NA 40	072910340		
7291NA 41	072910341		
7291NA 42	072910342		
7291NA 43	072910343		
7291NA 44	072910344		
7291NA 45	072910345		
7291NA 46	072910346		
7291NA 47	072910347		
7291NA 48	072910348		
7313G 35	073130635	7314AF 35	073140235
7313G 36	073130636	7314AF 36	073140236
7313G 37	073130637	7314AF 37	073140237
7313G 38	073130638	7314AF 38	073140238
7313G 39	073130639	7314AF 39	073140239
7313G 40	073130640	7314AF 40	073140240
7313G 41	073130641	7314AF 41	073140241
7313G 42	073130642	7314AF 42	073140242
7313G 43	073130643	7314AF 43	073140243
7313G 44	073130644	7314AF 44	073140244
7313G 45	073130645	7314AF 45	073140245
7313G 46	073130646	7314AF 46	073140246
7313G 47	073130647	7314AF 47	073140247
7313G 48	073130648	7314AF 48	073140248
7313B 35	073130835	7314AB 35	073140335
7313B 36	073130836	7314AB 36	073140336
7313B 37	073130837	7314AB 37	073140337
7313B 38	073130838	7314AB 38	073140338
7313B 39	073130839	7314AB 39	073140339
7313B 40	073130840	7314AB 40	073140340
7313B 41	073130841	7314AB 41	073140341
7313B 42	073130842	7314AB 42	073140342
7313B 43	073130843	7314AB 43	073140343
7313B 44	073130844	7314AB 44	073140344
7313B 45	073130845	7314AB 45	073140345
7313B 46	073130846	7314AB 46	073140346
7313B 47	073130847	7314AB 47	073140347
7313B 48	073130848	7314AB 48	073140348
7316N 35	073160535	7315AN 35	073150535

7316N 36	073160536	7315AN 36	073150536
7316N 37	073160537	7315AN 37	073150537
7316N 38	073160538	7315AN 38	073150538
7316N 39	073160539	7315AN 39	073150539
7316N 40	073160540	7315AN 40	073150540
7316N 41	073160541	7315AN 41	073150541
7316N 42	073160542	7315AN 42	073150542
7316N 43	073160543	7315AN 43	073150543
7316N 44	073160544	7315AN 44	073150544
7316N 45	073160545	7315AN 45	073150545
7316N 46	073160546	7315AN 46	073150546
7316N 47	073160547	7315AN 47	073150547
7316N 48	073160548	7315AN 48	073150548
7526 XS	075260046	7528 XS	075280046
7526 S	075260048	7528 S	075280048
7526 M	075260050	7528 M	075280050
7526 L	075260052	7528 L	075280052
7526 XL	075260054	7528 XL	075280054
7526 XXL	075260056	7528 XXL	075280056
7526 XXXL	075260058	7528 XXXL	075280058
7546BL XS	075460000	7547BL XS	075470200
7546BL S	075460001	7547BL S	075470201
7546BL M	075460002	7547BL M	075470202
7546BL L	075460003	7547BL L	075470203
7546BL XL	075460004	7547BL XL	075470204
7546BL XXL	075460005	7547BL XXL	075470205
7546BL XXXL	075460006	7547BL XXXL	075470206
7546G XS	075460100	7547G XS	075470300
7546G S	075460101	7547G S	075470301
7546G M	075460102	7547G M	075470302
7546G L	075460103	7547G L	075470303
7546G XL	075460104	7547G XL	075470304
7546G XXL	075460105	7547G XXL	075470305
7546G XXXL	075460106	7547G XXXL	075470306
7546N XS	075460200	7547N XS	075470400
7546N S	075460201	7547N S	075470401
7546N M	075460202	7547N M	075470402
7546N L	075460203	7547N L	075470403
7546N XL	075460204	7547N XL	075470404
7546N XXL	075460205	7547N XXL	075470405
7546N XXXL	075460206	7547N XXXL	075470406
7548BL XS	075480000	7549BL XS	075490200
7548BL S	075480001	7549BL S	075490201
7548BL M	075480002	7549BL M	075490202
7548BL L	075480003	7549BL L	075490203
7548BL XL	075480004	7549BL XL	075490204
7548BL XXL	075480005	7549BL XXL	075490205
7548BL XXXL	075480006	7549BL XXXL	075490206
7548G XS	075480100	7549G XS	075490300
7548G S	075480101	7549G S	075490301
7548G M	075480102	7549G M	075490302
7548G L	075480103	7549G L	075490303
7548G XL	075480104	7549G XL	075490304
7548G XXL	075480105	7549G XXL	075490305
7548G XXXL	075480106	7549G XXXL	075490306
7548N XS	075480200	7549N XS	075490400
7548N S	075480201	7549N S	075490401
7548N M	075480202	7549N M	075490402
7548N L	075480203	7549N L	075490403
7548N XL	075480204	7549N XL	075490404
7548N XXL	075480205	7549N XXL	075490405
7548N XXXL	075480206	7549N XXXL	075490406
7622G XS	076220000	7657N XS	076570000
7622G S	076220001	7657N S	076570001
7622G M	076220002	7657N M	076570002
7622G L	076220003	7657N L	076570003
7622G XL	076220004	7657N XL	076570004
7622G XXL	076220005	7657N XXL	076570005
7622G XXXL	076220006	7657N XXXL	076570006
7632G XS	076320000	7657N XS	076570000
7632G S	076320001	7657N S	076570001
7632G M	076320002	7657N M	076570002
7632G L	076320003	7657N L	076570003
7632G XL	076320004	7657N XL	076570004
7632G XXL	076320005	7657N XXL	076570005

ARTICOLI ELIMINATI - ARTICOLI SOSTITUTIVI/CONSIGLIATI

	ARTICOLO ELIMINATO
	ARTICOLO SOSTITUTIVO
	ARTICOLO CONSIGLIATO

7635G L	076350513	7635N L	076350503
7635G XL	076350514	7635N XL	076350504
7635G XXL	076350515	7635N XXL	076350505
7635G XXXL	076350516	7635N XXXL	076350506
7636BL XS	076360000	7654N XS	076540000
7636BL S	076360001	7654N S	076540001
7636BL M	076360002	7654N M	076540002
7636BL L	076360003	7654N L	076540003
7636BL XL	076360004	7654N XL	076540004
7636BL XXL	076360005	7654N XXL	076540005
7636BL XXXL	076360006	7654N XXXL	076540006
7683 S	076830001	7659N S	076590001
7683 M	076830002	7659N M	076590002
7683 L	076830003	7659N L	076590003
7683 XL	076830004	7659N XL	076590004
7683 XXL	076830005	7659N XXL	076590005
7683 XXXL	076830006	7659N XXXL	076590006
7684 S	076840001	7658N S	076580001
7684 M	076840002	7658N M	076580002
7684 L	076840003	7658N L	076580003
7684 XL	076840004	7658N XL	076580004
7684 XXL	076840005	7658N XXL	076580005
7684 XXXL	076840006	7658N XXXL	076580006
7685 S	076850001		
7685 M	076850002		
7685 L	076850003		
7685 XL	076850004		
7685 XXL	076850005		
7860E XS	078600900	7860G XS	078600800
7860E S	078600901	7860G S	078600801
7860E M	078600902	7860G M	078600802
7860E L	078600903	7860G L	078600803
7860E XL	078600904	7860G XL	078600804
7860E XXL	078600905	7860G XXL	078600805
7860E XXXL	078600906	7860G XXXL	078600806
7860E XXXXL	078600907	7860G XXXXL	078600807
7861E XS	078610900	7861G XS	078610800
7861E S	078610901	7861G S	078610801
7861E M	078610902	7861G M	078610802
7861E L	078610903	7861G L	078610803
7861E XL	078610904	7861G XL	078610804
7861E XXL	078610905	7861G XXL	078610805
7861E XXXL	078610906	7861G XXXL	078610806
7861E XXXXL	078610907	7861G XXXXL	078610807
7863E XS	078630900	7863G XS	078630800
7863E S	078630901	7863G S	078630801
7863E M	078630902	7863G M	078630802
7863E L	078630903	7863G L	078630803
7863E XL	078630904	7863G XL	078630804
7863E XXL	078630905	7863G XXL	078630805
7863E XXXL	078630906	7863G XXXL	078630806
7863E XXXXL	078630907	7863G XXXXL	078630807
7865E XS	078650900	7865G XS	078650800
7865E S	078650901	7865G S	078650801
7865E M	078650902	7865G M	078650802
7865E L	078650903	7865G L	078650803
7865E XL	078650904	7865G XL	078650804
7865E XXL	078650905	7865G XXL	078650805
7865E XXXL	078650906	7865G XXXL	078650806
7865E XXXXL	078650907	7865G XXXXL	078650807
7867E XS	078670900		
7867E S	078670901		
7867E M	078670902		
7867E L	078670903		
7867E XL	078670904		
7867E XXL	078670905		
7867E XXXL	078670906		
7867E XXXXL	078670907		
7869E XS	078690900	7869G XS	078690800
7869E S	078690901	7869G S	078690801
7869E M	078690902	7869G M	078690802
7869E L	078690903	7869G L	078690803
7869E XL	078690904	7869G XL	078690804

7869E XXL	078690905	7869G XXL	078690805
7869E XXXL	078690906	7869G XXXL	078690806
7869E XXXXL	078690907	7869G XXXXL	078690807
7870E XS	078700900	7860G XS	078600800
7870E S	078700901	7860G S	078600801
7870E M	078700902	7860G M	078600802
7870E L	078700903	7860G L	078600803
7870E XL	078700904	7860G XL	078600804
7870E XXL	078700905	7860G XXL	078600805
7870E XXXL	078700906	7860G XXXL	078600806
7870E XXXXL	078700907	7860G XXXXL	078600807
7871E XS	078710900	7861G XS	078610800
7871E S	078710901	7861G S	078610801
7871E M	078710902	7861G M	078610802
7871E L	078710903	7861G L	078610803
7871E XL	078710904	7861G XL	078610804
7871E XXL	078710905	7861G XXL	078610805
7871E XXXL	078710906	7861G XXXL	078610806
7871E XXXXL	078710907	7861G XXXXL	078610807
7873E XS	078730900	7863G XS	078630800
7873E S	078730901	7863G S	078630801
7873E M	078730902	7863G M	078630802
7873E L	078730903	7863G L	078630803
7873E XL	078730904	7863G XL	078630804
7873E XXL	078730905	7863G XXL	078630805
7873E XXXL	078730906	7863G XXXL	078630806
7873E XXXXL	078730907	7863G XXXXL	078630807
7875E XS	078750900	7865G XS	078650800
7875E S	078750901	7865G S	078650801
7875E M	078750902	7865G M	078650802
7875E L	078750903	7865G L	078650803
7875E XL	078750904	7865G XL	078650804
7875E XXL	078750905	7865G XXL	078650805
7875E XXXL	078750906	7865G XXXL	078650806
7875E XXXXL	078750907	7865G XXXXL	078650807
7877E XS	078770900	7867G XS	078670800
7877E S	078770901	7867G S	078670801
7877E M	078770902	7867G M	078670802
7877E L	078770903	7867G L	078670803
7877E XL	078770904	7867G XL	078670804
7877E XXL	078770905	7867G XXL	078670805
7877E XXXL	078770906	7867G XXXL	078670806
7877E XXXXL	078770907	7867G XXXXL	078670807
7879E XS	078790900	7869G XS	078690800
7879E S	078790901	7869G S	078690801
7879E M	078790902	7869G M	078690802
7879E L	078790903	7869G L	078690803
7879E XL	078790904	7869G XL	078690804
7879E XXL	078790905	7869G XXL	078690805
7879E XXXL	078790906	7869G XXXL	078690806
7879E XXXXL	078790907	7869G XXXXL	078690807
7900E XS	079000900	7900G XS	079000800
7900E S	079000901	7900G S	079000801
7900E M	079000902	7900G M	079000802
7900E L	079000903	7900G L	079000803
7900E XL	079000904	7900G XL	079000804
7900E XXL	079000905	7900G XXL	079000805
7900E XXXL	079000906	7900G XXXL	079000806
7900E XXXXL	079000907	7900G XXXXL	079000807
7901E XS	079010900	7901G XS	079010800
7901E S	079010901	7901G S	079010801
7901E M	079010902	7901G M	079010802
7901E L	079010903	7901G L	079010803
7901E XL	079010904	7901G XL	079010804
7901E XXL	079010905	7901G XXL	079010805
7901E XXXL	079010906	7901G XXXL	079010806
7901E XXXXL	079010907	7901G XXXXL	079010807
7903E XS	079030900	7903G XS	079030800
7903E S	079030901	7903G S	079030801
7903E M	079030902	7903G M	079030802
7903E L	079030903	7903G L	079030803
7903E XL	079030904	7903G XL	079030804
7903E XXL	079030905	7903G XXL	079030805
7903E XXXL	079030906	7903G XXXL	079030806
7903E XXXXL	079030907	7903G XXXXL	079030807
7904E XS	079040900	7904N XS	079040800
7904E S	079040901	7904N S	079040801
7904E M	079040902	7904N M	079040802
7904E L	079040903	7904N L	079040803

7904E XL	079040904	7904N XL	079040804
7904E XXL	079040905	7904N XXL	079040805
7904E XXXL	079040906	7904N XXXL	079040806
7904E XXXXL	079040907	7904N XXXXL	079040807
7905E XS	079050900	7905G XS	079050800
7905E S	079050901	7905G S	079050801
7905E M	079050902	7905G M	079050802
7905E L	079050903	7905G L	079050803
7905E XL	079050904	7905G XL	079050804
7905E XXL	079050905	7905G XXL	079050805
7905E XXXL	079050906	7905G XXXL	079050806
7905E XXXXL	079050907	7905G XXXXL	079050807
7907E XS	079070900	7907G XS	079070800
7907E S	079070901	7907G S	079070801
7907E M	079070902	7907G M	079070802
7907E L	079070903	7907G L	079070803
7907E XL	079070904	7907G XL	079070804
7907E XXL	079070905	7907G XXL	079070805
7907E XXXL	079070906	7907G XXXL	079070806
7907E XXXXL	079070907	7907G XXXXL	079070807
7909E XS	079090900	7909G XS	079090800
7909E S	079090901	7909G S	079090801
7909E M	079090902	7909G M	079090802
7909E L	079090903	7909G L	079090803
7909E XL	079090904	7909G XL	079090804
7909E XXL	079090905	7909G XXL	079090805
7909E XXXL	079090906	7909G XXXL	079090806
7909E XXXXL	079090907	7909G XXXXL	079090807
8061F 5,3	080610153	8061R 5,3	080610253
8085 1,5	080850016	8085 1500	080850215
8085 2,0	080850020	8085 2000	080850220
8085 3,15	080850032	8085 3150	080850232
8085 5,3	080850054	8085 5300	080850253
9507D S	095070061	9501TLD S	095010061
9507D M	095070062	9501TLD M	095010062
9507D L	095070063	9501TLD L	095010063
9507D XL	095070064	9501TLD XL	095010064
9537N M	095370102	9537TL M	095370052
9537N L	095370103	9537TL L	095370053
9537N XL	095370104	9537TL XL	095370054
9537N XXL	095370105	9537TL XXL	095370055
9549PB	095490051	9549BP	095490052
9549USB	095490061	9549C	095490062
9563P	095630010	9563U	095630020
11001 115X2,5	110010117	11001 115X3,2	110010118
11001 125X2,5	110010127	11001 125X3,2	110010128
11001 230X2,5	110010232	11001 230X3,2	110010233
11021 115X2,5	110210117	11021 115X3,2	110210118
11021 125X2,5	110210127	11021 125X3,2	110210128
11021 180X2,5	110210182	11021 180X3,2	110210183
11021 230X2,5	110210232	11021 230X3,2	110210233
11024 180X2,0	110240180	11037 2,0-22,23	110370022
11050S 230X7	110500430	11050 230X7	110500230
11100 5X10	111000005	11100 6X10	111000006
11100 6X13	111000007	11100 8X12	111000008
11101 3X6	111010003	11101 4X8	111010004
11232B 40	112320104	11230B 40	112300104
11232B 60	112320106	11230B 60	112300106
11246B 40	112460104	11248B 40	112480104
11246B 60	112460106	11248B 60	112480106
11310A 60	113100006	11300A 60	113000006
11310A 80	113100008	11300A 80	113000008
11310B 60	113100106	11300B 60	113000106
11310B 80	113100108	11300B 80	113000108
11310C 60	113100206	11300C 60	113000206
11310C 80	113100208	11300C 80	113000208
1			

Abbigliamento da lavoro	577÷591
Accessori per funi Robur	593÷627
Accessori portautensili per armadietti, cassetti e pareti	495÷497
Aerografi	309
Armadi per officina	396÷398, 410
Armadietti portautensili	366, 395
Arredamento Officina	374÷411
Artigli prensili flessibili	210
Ascia antiscintilla	288
Aspiratore per liquidi	238
Aspiratori per solidi e liquidi	235-236
Assortimenti di utensili	410÷495
Assortimenti utensili in moduli	410÷495
Attrezzi per il ripristino delle filettature	55-56
Autoriparazione	114÷122, 150÷156, 160÷189, 192÷198, 219÷221, 224-225, 237÷251
Avvolgicavo automatici con portalamпада	233
Avvolgitubo automatici per aria/acqua	233
Banchi da lavoro	365, 367÷373, 378÷380
Barre dinamometriche	70-71
Bauli portautensili	321
Beta Abrasives	503÷519
Beta Chemicals	498÷502
Beta Collection	629÷639
Bloccante	500
Bordatubi	42
Borse portautensili	314÷319
Bulini	23
Cacciaspina	23, 281
Calibratore per tubi multistrato	42
Calibri a corsoio	202-203
Carrello pieghevole	323
Carrelli portautensili	339÷341, 360÷362, 389
Carrello porta cassettiere	325
Cartelli di avvertenza e divieto	590
Cassettiere mobili	327÷339, 345÷356, 384-385, 407
Cassettiere per industria	345-346
Cassettiere portatili	325-326, 351-352
Catene e colonnine in plastica di delimitazione	590
Cesoie	131-132
Cesoie a cricchetto per tubi PVC	41
Cestelli portautensili	318÷321
Chiavi a bussola con impugnatura	112, 265
Chiavi a bussola Macchina, accessori e assortimenti	73÷79
Chiavi a bussola snodate doppie	28
Chiavi a bussola, accessori e assortimenti 1/4"	86÷92
Chiavi a bussola, accessori e assortimenti 3/8"	87÷98, 263-264, 283-284
Chiavi a bussola, accessori e assortimenti 1/2"	98÷107, 264, 277, 284-285
Chiavi a bussola, accessori e assortimenti 3/4"	107÷109, 284-285
Chiavi a bussola, accessori e assortimenti 1"	109
Chiavi a cricchetto	30, 36÷39
Chiavi a forchetta	26÷28, 263, 281-282



Chiavi a percussione	27-28, 282
Chiavi a pipa	110-111, 285
Chiavi a settore	36, 283
Chiavi a T con bussola esagonale e Torx®	112÷114
Chiavi a T maschio esagonale e Torx®	113-114, 265, 285
Chiavi a tubo	110-111
Chiavi a zampa di gallo	96
Chiavi combinate	24÷26, 37-38, 276, 281
Chiavi di manovra antiscintilla per valvole	285
Chiavi e barre dinamometriche	65÷72
Chiavi maschio esagonale e Torx® con impugnatura	33÷35, 265, 277
Chiavi maschio esagonale e Torx®, piegate	30÷35, 276, 283
Chiavi maschio piegate a profilo XZN®	35
Chiavi per ponteggi	29-30, 282
Chiavi per quadristi	199
Chiavi per raccordi	30, 36, 38
Chiavi poligonali	28÷30, 263, 282-283
Chiavi regolabili a rullino	36, 263, 277, 283
Colla istantanea	501
Coltelli	227, 288
Combo valigette e accessori	322÷324
Comparatori	203
Compassi	205
Compressori a leva per grasso	217
Contafiletti	209
Contalitri per olio	238
Curvatubi	45
Cuscino sollevatore	228
Cutter	226
Detergenti	502
Dischi abrasivi	505÷507, 518
Dischi lamellari	511÷515
Estrattori a due griffe	190÷192, 198
Estrattori a tre griffe	191-192, 198
Estrattori coni Morse	53
Estrattori idraulici	185
Estrattori per mozzi ruote	192-193
Estrattori per viti e prigionieri danneggiati	160-161
Estrattori vari	192÷194
Fascette	522÷525
Filiere e assortimenti	57÷60
Flessibili magnetici	209-210
Flessometri e metri	206-207
Forbici	133, 228, 288
Forbici per elettricisti	132-133, 265
Frenafili	499
Frese coniche	51
Fustelle	130-131
Gamma blister	526÷539
Giramaschi e girafiliera	55, 58
Giratubi	43÷45, 277, 283
Giravite a battere	142
Giravite a percussione	149-150



Giravite a squadra	142
Giravite BetaEVOX	139÷141
Giravite BetaGrip	144÷148, 266-267
Giravite BetamaX	148÷150, 278, 286
Giravite bivalenti	147-148
Giravite cercafase	143
Giravite dinamometrici	65
Giravite prensili	142
Goniometri per serraggi angolari	66
Goniometri semplici	205
Grasso spray	501
Guanti isolanti	267
Guarnizione liquida	500
Idraulica, vari	39÷45
Ingrassatore a leva	218
Inseriti per avvitatori e portainseriti	36, 39, 79÷86, 143, 263
Lampade	230-231
Leve	120, 209, 285
Lime	152, 211÷214, 288
Livelle e stadie	207-208
Magnetizzatore-smagnetizzatore	139
Martelli	152-153, 156÷159, 278, 287
Martinetto idraulico	198
Maschera per saldatura	235
Mascherina antipolvere	590
Maschi e assortimenti	53÷55, 59-60
Matita per falegnami	206
Mazze	158, 287
Mazzette	158, 287
Mazzuole	159, 287
Microgiravite	142÷144
Micrometri	203
Misuratori di coppia elettronici Dynatester	65, 72
Misuratori laser	207
Moduli portautensili	469÷495
Mole abrasive con gambo	508÷511
Moltiplicatori di coppia	63-64
Morse parallele da banco	199
Morse ribaltabili da banco, per idraulica	45
Morsetti	198-199
Morsetti di coda	522
Multimetri	221-222
Nastro isolante	525
Occhiali di protezione	590
Oliatori	218-219
Pala antiscintilla	288
Paranchi	611
Pareti portautensili	369, 393, 411
Pennello	215
Piccone antiscintilla	288
Pinza foralamiera	128
Pinza fustellatrice	224
Pinza piegalamiera	128



Pinze a becchi lunghi e lunghissimi	124, 135÷138, 266, 286
Pinze amperometriche	222
Pinze autobloccanti	126÷128
Pinze per anelli elastici di sicurezza	124-125, 285-286
Pinze per capicorda e capicorda	199÷201,
Pinze per elettronica	137-138
Pinze per fascette	217, 525
Pinze regolabili	125-126, 134, 265, 277, 286
Pinze torcifilo	224
Pinze universali	135, 265, 277, 286
Pinzette a molla	122÷124, 265
Pistola per olio	238
Pistole per colla	233
Pistole per sigillanti	217
Pistole termiche	233
Polifusori e matrici	39
Pompa oleodinamica	153
Pompe per barili	238
Pompette per dissaldare	229
Porta attrezzi con cintura	314
Portacarta	337
Portaflaconi	337
Portaminuterie magnetici	225
Postazione di lavoro mobile	344
Protezioni per cassettiere	355, 362
Provatensione	223
Pulitore spray	502
Punte elicoidali cilindriche per forare	46÷50
Punte per forare, filettare e svasare	57
Punte per tracciare	206
Punte speciali per saldature	51
Punteruoli	210
Punzonatrice oleodinamica	201-202
Punzoni	23, 281
Raggimetri	209
Rapportatore d'angoli	205
Raschietti	176, 210-211, 226, 288
Righe graduate	205
Rinvio angolare	86
Ripara plastiche	156
Rivettatrici e rivetti	215÷217
Rotoli antispreco	519
Ruote lamellari e in tessuto	517-518
Saldatori	228-229
Saldatrici	234
Sbavatori per tubi	42
Sbloccante spray	501
Scalpelli	23, 281
Scalpelli per carrozzieri	122, 152
Scalpelli per edilizia	208
Scarpe antinfortunistiche	552÷576
Segaccio per legno	214
Seggiolini con rotelle	243-244



Seghe e frese a tazza e accessori	60÷62
Seghetti e lame	214-288
Segoncino ad arco	214
Serraggiunti e strettoi	198-199
Sigillaraccordi	499
Silicone spray	501
Siringa per olio	219
Soluzioni per il punto vendita	540÷552
Sonda tirafili	201
Spaccadadi	209
Spatole	214, 278
Spazzole	215, 288
Specchietti	210
Spellacavi e spellafili	134
Spessimetri	209
Squadre	204-205
Squadre magnetiche per saldatori	234-235
Supporto per avvitatore pneumatico	295
Tachimetro digitale	223
Tagliacavi	133
Tagliacavi per cavi in acciaio	133
Tagliafuni di acciaio	130
Tagliatubi	39÷41
Tappeto da lavoro	254, 371, 399, 639
Tappeto isolante	267
Tappeto protezione ginocchia	244
Tenaglie	129-130
Tenditore per molle	214
Terminali preisolati	521
Termocamera	224
Termometri	223-224
Termoplastre per tubi plastici	39
Torçe	229-230
Traccialinea e polvere	209
Trolley portautensili	315, 318-319, 357÷359
Troncabulloni	130
Tronchesi a taglienti diagonali e frontali	128-129, 138-139, 265, 277, 286
Tronchesi per elettronica	138-139
Ugnetti	24
Utensili a batteria	289
Utensili anticaduta	268÷274
Utensili antiscintilla	280÷288
Utensili in acciaio inossidabile	275÷279
Utensili isolati 1000V	261÷267
Utensili per biciclette	257÷260
Utensili per motocicli	252÷256
Utensili pneumatici ed accessori	290÷312
Valigie portautensili	314÷317, 322÷324
Vasca di lavaggio ad ultrasuoni	242
Ventose	224-225
Videoscopio elettronico	119
Zaini portautensili	317
Zinco spray	502

Automotive



Alesatori per sedi iniettori	119
Aspiratore di vapori iniettori Diesel	119
Asta telescopica	225
Attrezzi per centraggio frizioni	161
Attrezzi per estrazione autoradio	224
Attrezzi per pistoni	162
Attrezzi per pulegge distribuzione	167
Attrezzi per rimozione cristalli	225
Attrezzi per sostituzione piattelli valvole	170
Attrezzi per tubi scarico	174
Attrezzo levabolli	153
Attrezzo per pistoncini freni a disco	171
Attrezzo per smagliatura catene	256
Avviatori	185-186
Barre di torsione per dadi ruote	78
Calibri a corsoio per dischi e tamburi freni	202
Calibro per battistrada pneumatici	209
Caricabatteria	187
Carrello per cambi/trasmissioni	362
Carrello per movimentazione veicoli	246
Carrello sottoscocca	246
Cavalletti	246
Cavalletti per moto	253
Chiave per braccetti sterzo	197
Chiave per turbine	174
Chiavi a bussola Macchina per dadi assale	120
Chiavi a bussola Macchina per dadi ruote	74-75
Chiavi a bussola Macchina quadre per dadi ruote Isuzu	77
Chiavi a bussola per dadi mozzi ruote	120-121
Chiavi a bussola per dadi mozzi ruote veicoli pesanti	121
Chiavi a bussola per iniettori Diesel	115
Chiavi a bussola per perni balestre	196
Chiavi a bussola per sonda Lambda	116
Chiavi a croce per dadi ruote	121
Chiavi e bussole per candele d'accensione	115
Chiavi per filtri gasolio	182
Chiavi per filtri olio motore	180
Chiavi per ghiera galleggiante serbatoio	176-177
Chiavi per raccordi carburante	166
Chiavi per sensori di temperatura	117
Chiavi per tappi scarico olio motore	183
Chiavi per valvole metano	179-180



Densimetro per liquido anticongelante	220
Densimetro per liquido batteria	220
Estrattore per raschiavetri	225
Estrattori per giunti omocinetici	197
Estrattori per pioli	175
Estrattori per snodi sferici	197
Fustelle per sensori parcheggio	155
Gru idraulica pieghevole	247
Imbuto	219-220
Inseritori a percussione per cuscinetti conici e paraoli	198
Lamina modellabile in alluminio	220
Lettini sottomacchina	244-245
Leva per cambio DSG	161
Leva per estrazione testine braccio oscillante	197
Levagomme	119-120
Leve per carrozzieri	151
Lime per carrozzieri	152
Martelli per carrozzieri	152
Messa in fase	163
Morsetti alzavalvola	162
Perni guida montaggio ruote	121-122
Piastra di riscontro bolli	153
Pinza per anelli di tenuta valvole	163
Pinza per anelli elastici di sicurezza SP	163
Pinza per copertura plastiche delle ruote	121
Pinza per equilibratura ruote	122
Pinza per graffette	224
Pinze per anelli stringitubo	172
Pinze per cappucci candele	173-174
Pinze per freni	170-171
Pinze per occlusione tubi e manicotti	176
Pinze per raccordi rapidi tubi carburante	177
Pistola per gonfiaggio pneumatici	308
Pompa per taratura e controllo iniettori Diesel	119
Postazione mobile per strumenti diagnosi	360
Presse idrauliche	249
Pressori per molle ammortizzatori	195
Protezioni per auto	244
Protezioni per ruote	121
Provatensione	185
Rabbocicatori per batterie	219
Recuperatori olio esausto	237
Rilevatore di segnale	223
Sabbiatrice da banco	243
Smerigliavalvole pneumatico	162
Sollevatore ruote truck	246
Sollevatori idraulici a bottiglia	246

INDICE ALFABETICO UTENSILI PER AUTORIPARAZIONE



Sollevatori idraulici a ruote	250
Sollevatori idraulici da fossa	248
Sollevatori oleopneumatici	251
Sostegni motore	247
Spatoline in acciaio Inox	152
Spazzola per morsetti batteria	215
Spessimetri per carrozzieri	152
Spotter carrellato per carrozzeria	154
Stabilizzatore di tensione	189
Stazione di ricarica climatizzatori	241
Stazione per cambio automatico	239
Stetoscopio	189
Strumenti estrazione liquido freni	170
Strumenti per controllo impianto raffreddamento	220
Strumento per controllo compressione motori a benzina e Diesel	117
Strumento per sensori di pressione dei pneumatici	121
Tassi per carrozzieri	150
Tenditori per molle	160
Tester digitale pressione e compressione	167
Tester per batteria e impianti di ricarica	189
Tirabolli pneumatico	154
Utensile per rimozione guarnizioni	193
Utensili per airbag	161
Utensili per bobine candele	173
Utensili per connessioni elettriche	185
Utensili per estrazione silent block	197
Utensili per impianti di condizionamento	177
Utensili per iniettori Diesel Common Rail	117
Utensili per riempimento filtri gasolio	176
Utensili per rimozione candele preriscaldamento	118
Utensili per valvole pneumatici	122
Utensili per veicoli pesanti	121
Vasca per pulizia pezzi	343
Vasche per recupero liquidi	237-238



1		1031/S4	124	1067	128	1122K	532	1150HPC	135
		1032	124	1077	128	1123	131	1150INOX	277
		1032BA	285	1078	128	1123K	532	1150K	533
100	36	1032HS	271	1080D	128	1124	131	1150MQ	265
100/KIT	36	1032K	531	1081	128	1124K	532	1153	135
110BA	283	1033	125	1082	128	1125	132	1153INOX	277
110MQ	263	1033K	531	1082BA	286	1126	132	1162	135
111	36	1034	125	1082BM	128	1127	132	1162BA	286
111G	36	1034HS	271	1082BM-HS	271	1128BAX	132	1162BM	135
111HS	270	1034K	531	1082BMK	531	1128BAX-HS	271	1162BMK	533
111INOX	277	1034L	125	1082G	128	1128BCX	132	1162G	135
111K	528	1036	125	1082GBM	129	1128BM	133	1162GBM	135
111N	36	1036BA	286	1082GBMK	531	1128BMX	132	1162GBMK	533
120	36	1036HS	271	1082GK	531	1128BMX/F	132	1162GK	533
120/B	36	1036K	531	1082INOX	277	1128BSX	132	1162K	533
123/K4	37	1037	125	1082K	531	1128FX	132	1162MQ	266
123E1/4	36	1037K	531	1082MQ	265	1128FXS	133	1164	135
123Q1/2	37	1038	125	1084	129	1128MQ	265	1164BM	136
123Q1/4	37	1038HS	271	1084BM	129	1129BM	133	1164BMK	533
123Q3/8	37	1038K	531	1084BMK	532	1129BMK	533	1164K	533
141	37	1039	125	1084G	129	1130BMX	133	1164MQ	266
141/B	37	1044	125	1084GBM	129	1131CK	133	1166	136
141/S	37	1044F	125	1084GBMK	532	1132	133	1166BA	286
142	37	1044FK	531	1084GK	532	1132BM	133	1166BM	136
142/B	37	1044K	531	1084K	531	1132BM-HS	271	1166BM-HS	272
142/S	37	1046	125	1084MQ	265	1132BMK	533	1166BMK	534
142/SC9I-E	37	1046BA	286	1088	129	1132K	533	1166G	136
142AS	38	1046K	531	1088BM	129	1132MQ	265	1166GBM	136
142AS/S	38	1047	125	1088BM-HS	271	1133	133	1166GBMK	534
142C	38	1047BM	126	1088BMK	532	1133RL	133	1166GK	534
142C/A	38	1048	126	1088K	532	1134	133	1166K	534
142HS	270	1048BM	126	1088MQ	265	1134A	133	1166MQ	266
142K	528	1048BM-HS	271	1092V	129	1134A/RL	133	1168	136
142MC	38	1048INOX	277	1094V	129	1134RL	133	1168BM	136
142MC/SC9I-E	38	1048K	531	1095N	129	1136	133	1168BM-HS	272
142SN	38	1048MQ	265	1096	129	1137BA	286	1168BMK	534
142SN/S	38	1048V	126	1096K	532	1137BA/RC	286	1168G	136
186	38	1048VK	531	1098	130	1142BM	134	1168GBM	136
187	38	1050	126	1098K	532	1142BMK	533	1168GBMK	534
187/B5	38	1051	126	1098PL	130	1142MQ	265	1168GK	534
188	38	1051GM	126	1098PLK	532	1143	134	1168K	534
192	38	1051L	126	1100BA 600	286	1143R	134	1168MQ	266
192/S2	39	1051XL	126	1101	130	1144D	134	1169/D3	136
194	39	1052	126	1101R	130	1144D/RG	134	1169BM/D3	137
195	39	1052BA	286	1102	130	1144D/RL	134	1169G/D3	136
195/B5	39	1052HS	271	1104	130	1144G	134	1169GBM/D3	137
195AS	39	1052K	531	1104R	130	1144G/RL	134	1171BM	137
195AS/B	39	1053	126	1105	130	1144L	134	1172BM	137
195K	528	1054	127	1105/C10T	131	1148A	134	1172BM/P	137
195P	39	1055	127	1105/C15T	131	1148A/R	134	1173BM	137
195P/B5	39	1056	127	1105/C29T	131	1148B	134	1175BM	137
1002	124	1057A	127	1105AD-50	131	1148B/R	134	1177BM	137
1008	124	1058	127	1105T20	130	1148P	134	1177BM/Z	137
1008BM	124	1059	127	1105T30	130	1149F	134	1178BM	138
1009	124	1060	127	1105T50	131	1150	135	1178BM/P	138
1009L/A	124	1061	127	1112	131	1150BA	286	1182BM	138
1009L/B	124	1062	127	1112K	532	1150BM	135	1183BM	138
1009L/C	124	1062AL	127	1114	131	1150BM-HS	272	1184BM	138
1009L/D	124	1062GM	127	1118	131	1150BMK	533	1185BM	138
1009L/DP	124	1063	128	1120A	131	1150G	135	1186BM	138
1010	124	1064	128	1120ARL - ARG	131	1150GBM	135	1188BM	139
1010BM	124	1065F	128	1122	131	1150GBMK	533	1190BM	139
1010MQ	265	1065P	128	1122 - 1125MOL	132	1150GK	533	1191BM	139

INDICE ALFANUMERICO

1191BM/L	139	1256TX	143	1273MQ/F-D6	266	1297TX/S12	150	1366S/R8	155
1191R/5-M	139	1257BE	144	1274MQ	266	1298RTX	150	1366S/R9	155
1200MS	139	1257ES	144	1274MQ/F	266	1298RTX/S8	150	1366S/R10	155
1201E	139	1257ESB/S8	144	1274MQ/S	266	1298RTXK	536	1366S/R11	155
1201E/DZ	139	1257LP	143	1275MQ/C	266	1299HS	272	1366S/R12	155
1201E/K	534	1257LP/S	144	1276MQ/C	267	1299N/PZ	150	1366S/R13	155
1201E/S6	139	1257LPH/S8	144	1277BA	286	1299N/PZK	536	1366S/R14	155
1201EN	139	1257PH	144	1279MQ	267	1299PZ	150	1366S/R21	155
1201EN/K	534	1257TX	144	1279MQ/F	267	1299PZ/S6	150	1366S/R22	155
1202E	140	1257TX/S	144	1279MQ/S	267	1299PZK	536	1366S/R24	155
1202E/K	534	1260	144	1281/B28A	148	1302	150	1366S/R25	155
1202E/S4	140	1260/S6	144	1281BG	147	1303	151	1366S/R26	155
1202EL	140	1260E	145	1281BG/A9	147	1304	151	1366SL	154
1202EN	140	1260EK	535	1281BG/B28A	148	1305	151	1366ST	154
1202EN/K	534	1260K	535	1281BG-TX/A8	147	1305Z	151	1367/K10	155
1203/E1P	541	1260N	144	1281LP	147	1306	151	1367/S4	155
1203/E4P	541	1260NK	535	1281LPH	147	1307	151	1368	156
1203/E5P	542	1262	145	1281PB	147	1308	151	1368G/C2U	156
1203/E10P	542	1262/S4	145	1281PE	147	1309	151	1368G/CV	156
1203E/D	140	1262E	145	1281PH	147	1310	151	1368G/K400	156
1203E/S	140	1262EK	535	1281PM	147	1312	151	1368G/OD	156
1204E	140	1262K	535	1281PZ	147	1313	151	1368G/SD	156
1204E/K	534	1262L	145	1281RTX	147	1314	151	1369/C11	156
1204E/S5	140	1262N	145	1281TX	147	1326	151	1370	156
1204EL	141	1262NK	535	1290	148	1327	151	1370/MR...	156
1205E/ES	141	1263/D...	145	1290/S	148	1328	151	1370BA	287
1205E/ES-S8	141	1263/E39	543	1290HS	272	1329	152	1370BA/MR	287
1206E/BP	141	1263/E40	543	1290INOX	278	1330	152	1370BA/PL	287
1206E/BP-S7	141	1263/E50	543	1290K	536	1331	152	1370F	156
1207E TX/K	534	1263/E62	543	1290K/INOX	536	1335BM	152	1370F/MR...	157
1207E/TX	141	1263/E70	542	1290N	148	1337/S5	152	1370FT	157
1207E/TX-D	141	1263/E74	542	1290NK	536	1338	152	1370FT-HS	272
1208E/RTX	141	1263/E78	542	1292	148	1338A - 1338B	152	1370INOX	278
1208E/RTX-D	141	1263/E85	542	1292/S4	148	1338R9 - 1338R12	152	1370T	156
1208E RTX/K	534	1263/S12	145	1292HS	272	1342	152	1370T-HS	272
1209E/PZ	141	1264	145	1292INOX	278	1342PM	152	1374F	157
1209E PZ/K	534	1264/S5	145	1292K	536	1342PMR	152	1374F/MR...	157
1209E/PZ-S4	141	1264K	535	1292K/INOX	536	1343	152	1375	157
1209EN/PZ	141	1264L	146	1292L	148	1344	152	1375/MR	157
1209EN-PZ/K	535	1265ES	146	1292N	148	1345	152	1375A	157
1229LP	142	1265ES/S8	146	1292NK	536	1351	152	1375B	157
1229LP/S	142	1266BP	146	1293/D...	149	1353	152	1375BA/PL	287
1229LPH/A6	142	1266BP/S8	146	1293/S...	149	1357Z/45	153	1376X	157
1229PH	142	1267TX	146	1293BP	149	1359T	153	1376X/MR	157
1236B	142	1267TX/D7	146	1293BP/S	149	1360/K6	153	1376XT	157
1238B	142	1267TX/S13	146	1293BX/DA	544	1360/KP3	153	1376XT/MR	157
1241	142	1267TXK	535	1293BX/DD	544	1360G	153	1377	157
1242	142	1268RTX	146	1293BX/DE	544	1361/C12	153	1377/MR...	157
1243/D7	142	1268RTX/S8	146	1293BX/DF	544	1362	153	1377BA	287
1250	142	1268RTXK	535	1293ES	149	1365/K13	153	1377BA/PL	287
1251	142	1269N/PZ	147	1293ES/S7	149	1365P10	153	1377INOX	278
1252/S5	142	1269N/PZK	535	1293INOX/D8	278	1366/K5	154	1377T	158
1253	143	1269PZ	146	1294	149	1366A	153	1378	158
1253A	143	1269PZ/S4	146	1294/S7	149	1366KF	154	1378/MR...	158
1254	143	1269PZK	535	1294HS	272	1366S	154	1379BA	287
1256/20	143	1270BA	286	1294K	536	1366S KIT	154	1379F	158
1256/30	143	1272BA	286	1294L	149	1366S/R1	154	1379F/MR...	158
1256/C36-2	143	1272MQ	266	1295	149	1366S/R2	154	1380	158
1256LP	143	1272MQ/F	266	1295/C14	150	1366S/R3	154	1380/MR...	158
1256PE	143	1272MQ/S	266	1297TX	150	1366S/R4	154	1380BA	287
1256PH	143	1273MQ/D6	266	1297TX/D6	150	1366S/R5	154	1380BA/MR	287
1256PZ	143	1273MQ/E1	543	1297TX/L	150	1366S/R6	154	1380BA/PL	287
1256RTX	143	1273MQ/E2	543	1297TX/L-S5	150	1366S/R7	154	1380S	158

INDICE ALFANUMERICO

1380S/MR...	158	1461/C6G	163	1467/RK2	170	1478	175	1489/31T	180
1380T	158	1461/C7B	163	1467LF/2	170	1478/3P	175	1489/33	180
1381	158	1461/C8B	163	1467LF/RC	170	1478T	175	1489/33P	180
1381/MR...	158	1461/C8G	163	1467TU	170	1479	175	1489/C14	180
1381BA	287	1461/C9B	163	1468N	170	1479/B27	175	1489/E	180
1381BA/MR	287	1461/C10G	164	1470	170	1479L/S2	175	1489/Y	180
1381BA/PL	287	1461/C11A	164	1470FT	170	1479LB/C5	175	1489R	180
1381T	158	1461/C11G	164	1470PF	170	1479LV/S3	175	1490	180
1385	159	1461/C12A	164	1471	171	1479ML/B17	175	1490/R1 - 1490/R2	180
1385/MR	159	1461/C12G	164	1471A	171	1479ML/S3	175	1490F	181
1390	159	1461/C13A	164	1471CF	171	1479N/S5	175	1491	181
1390/MR...	159	1461/C13B	164	1471CM	171	1479RB/1	176	1491A	181
1390BA	287	1461/C17B	164	1471CM/E11	172	1479RB/2	176	1491R	181
1390BA/R	288	1461/C18B	164	1471D2	172	1479RB/3	176	1491T	181
1390HS	272	1461/C20G	165	1471GF	171	1479U/13	176	1492/1 - 1492/2	181
1390N	159	1461/C21G	165	1471M/50	171	1479U/32	176	1492T	181
1390NR	159	1461/C22B	165	1471M/C22	171	1480	176	1493	181
1390R	159	1461/C23B	165	1471M/P	171	1481/C12	176	1493/C7	183
1391	159	1461/C24B	165	1471M/W50	171	1481K/S4	176	1493/C19	182
1391A	159	1461/C25G	165	1471PN/B1	171	1481PL	176	1493/C30	182
1392	159	1461/C26B	165	1471PN/B2	171	1481PL/S3	176	1493/PF	181
1392HS	273	1461/C27G	165	1471PN/B3	171	1482	176	1493/S-U	183
1392R	159	1461/C28B	165	1471PN/B4	171	1482/8 - 1482/10	177	1493AL	182
1393	159	1461/C29B	166	1471PN/B5	171	1482A/1	177	1493AL 4S	182
1410/M	160	1461/C30G	166	1472	172	1482A/3	177	1493AL CF	182
1428	160	1461/C31B	166	1472AU	172	1482A/5	177	1493B	181
1428L	160	1461/C32G	166	1472AU/P	172	1482B	177	1493B/S5	181
1428L/B3	160	1461/C33B	166	1472AU/RP	172	1482C	177	1493DSG	182
1428/SB11	160	1462AD/BSC	167	1472FC	172	1482D	177	1493FF	182
1429	160	1462AD/SMN	167	1472FC/GE	172	1483K/12	177	1493FT	182
1429/SB7	160	1462/EI	167	1472FC/L	172	1483K/22	177	1493H	183
1430/...	160	1462/KD	166	1472FCA	172	1483KV-PT/S7	177	1493J	182
1430/S	160	1462/KI	166	1472FCL/RP	172	1484	177	1493VW	182
1431/...	160	1462/KMRC	167	1472H	172	1484PSA	178	1493X	183
1431/C5	160	1462/KU	167	1472MT/VW	172	1485/KIT	178	1493Y	183
1433	160	1462/CF	166	1472R/AU	172	1485BP	178	1494	183
1433/C11	161	1462/CF/C6	166	1472TM	173	1485BPM	178	1494/C14A	184
1435	161	1462/CF-SN/C6	166	1472VW	173	1485FCA/K2	178	1494BMW	183
1435R	161	1462/PIM	167	1473	173	1485FCA/T	178	1494E	183
1435/1	161	1463/KIT	167	1473A	173	1485FCA/TS	178	1494FPC	183
1435/1R	161	1464/AP	168	1473FN	173	1485FRD/T	178	1494Q	183
1437/C12	161	1464/AP T	168	1473Q	173	1485MJ	178	1494T	183
1438	161	1464/AP T16X12	168	1473P	173	1485MRC/T	178	1494VW	183
1438DCT	161	1464/ADB	168	1473T	173	1485PMTJ	178	1494VW/K	184
1438DSG	161	1464/APB	168	1474/C4	173	1485R	179	1494M	184
1438EVO	161	1464/FAP	169	1474E/VW	173	1485R/P10	179	1494XZN	183
1438R	161	1464/FG	168	1474E/VW2	173	1485R/P17	179	1495M	184
1438SAC	161	1464/FG/CP4	168	1474DL	174	1485TC	178	1495/C6	184
1439/K7	162	1464/IC	168	1474G	174	1485VAG	179	1495T	184
1440/...	162	1464/IC/RK	168	1474L	173	1485VAG/K2	179	1496/C	184
1445/1 - 1445/2	162	1464/PB	168	1475U	174	1485VLV/T	178	1497/C23	185
1450GC	162	1464/PF	169	1476	174	1486/10	179	1497/C94	185
1452K	162	1464/PT	169	1476/RC	174	1486/20	179	1497/S3	185
1452PN/K	162	1464/T	167	1476A	174	1486/30	179	1497CEL	184
1455SVP	162	1464T/SP80	167	1476A/RC	174	1486/40	179	1497D	184
1455SVP/R...	162	1464TDI	169	1476C/1	174	1486/50	179	1497KB/S3	185
1456/C8	162	1464VD	169	1476GT	174	1486/60	179	1497P	184
1457/B4	162	1465	169	1476PSA	174	1486/70	179	1497RC	185
1458	163	1466/C5	169	1476T	174	1486/80	179	1498	185
1460F	163	1466L 11	169	1477/C10	174	1486/90	180	1498/2A	187
1461/C3B	163	1466TLF	170	1477D	174	1488 - 1488L	180	1498/2A-8A-PR	187
1461/C5G	163	1467	170	1477D/S5	174	1488/1	180	1498/4A	187
1461/C6B	163	1467/RK1	170	1477K/7	175	1488R...	180	1498/4A-8A CO	187

INDICE ALFANUMERICO

1498/4A-8A CP	187	1540	193	1599T	199	1658SP/1	203	1701PMR	208
1498/8A	187	1542/1 - 1542/2	194	1600Q 8	199	1659	203	1702N	208
1498/12	186	1544/...	194	1600Q 10	199	1662/1 - 1662/2	203	1702N/PM	208
1498/12-24 R20	186	1545/C5M	194	1601/PC	199	1662AN	203	1702PMR	208
1498/16A	187	1547/C6	194	1602	199	1662DGT/A	203	1703BA/A	288
1498/24	186	1547KP	194	1602/C9	200	1662SP0	203	1703BA/P	288
1498/30A	188	1547P	194	1602A	200	1662SP2	204	1703BA/PL	288
1498/40A	188	1547PC/2	194	1602A-HS	273	1666	204	1704	209
1498/50A	188	1547PL/2	194	1602BA	288	1666A	204	1704A	209
1498/120A	188	1549	194	1603	200	1668	204	1704C	209
1498B12/R02	186	1550U	195	1603A	200	1668A	204	1705	209
1498C/24	186	1550U/CGS-R	195	1603B	200	1670	204	1705PT	209
1498LT/12	186	1550U/MRC-ABE	195	1603BK	537	1670A	204	1706DGT	209
1498LT/12-R7	186	1550U/MRC-C	195	1603K	536	1672	204	1707	209
1498LT/12-SF	186	1550U/S...	195	1606/2	200	1672A	204	1707A/1 - 2 - 3	209
1498MN/12	185	1550U/SS187	195	1606A	200	1674A	205	1708/8 - 13 - 20	209
1498MN/12-C	185	1550U/M	195	1606A/C9	200	1676	205	1708HS/20	273
1498MN/12-P	185	1551/C20	195	1606T	200	1678/C3	205	1709/10 - 1709/18	209
1498MN/12-R	185	1552/C9	195	1607	200	1679	205	1710	209
1498MN/12-U	186	1555/Q	196	1608	201	1679/PR	205	1712E/1 - 2 - 3	209
1498PC	189	1555/QS	196	1608/C9	201	1680	205	1712E/L1	209
1498SA/2A-4A	187	1555C	196	1608A	201	1680A	205	1712E/R-L1	210
1498SM	188	1555S/BMW-RNT	196	1609	201	1680B	205	1712TF	210
1498SM-A	189	1556/1A	196	1609A	201	1680C	205	1713M	210
1498SM-C	189	1556/2A	196	1609B	201	1682	205	1714	210
1498SM-CP	189	1557	196	1609C/C5	201	1682HS	273	1715	210
1498ST/TB	189	1557/S3	196	1609M	201	1683	205	1715B/R5L	210
1498ST/TB ROT	189	1557V	196	1610-B	521	1685/C7	206	1715FL/A	210
1498TB/12-24	189	1558/C4	196	1614-P	521	1687A	206	1715FL/B	210
1498TC	189	1558/C13	196	1616-SM	521	1687AC	206	1715R/FL	210
1499	189	1558P	196	1618-SF	521	1687D	206	1716A	210
1500/...	190	1559	197	1620-M	521	1687U	206	1716P	210
1500/SP	190	1559V/8T	197	1622-F	521	1687/S4	206	1716Q	210
1500G/...	190	1560/1 - 1560/2	197	1624-FI	521	1688	206	1716R	210
1500N/...	190	1560A	197	1628-C	521	1688A	206	1716U	210
1500N/G...	190	1561/...	197	1630-CR	521	1688M	206	1717A	210
1500N/SP	190	1562D	197	1632-TS	521	1688PC	206	1717B	210
1501/1 - 2 - 3	190	1565/1 - 2 - 3	197	1634-TD	521	1688PC/R	206	1717BA	288
1501G/1 - 2 - 3	190	1566/GO1	197	1635-S	522	1690F	206	1717BA/1	288
1501Z/S - P - R	190	1566N	197	1639EAB	525	1690L	206	1717C	210
1505/C5	191	1566P	197	1639ESB	525	1691BM	206	1717D	210
1505V	191	1567	197	1639ESC	525	1692	206	1717T	210
1506	191	1569/A	197	1639ETA	525	1692HS	273	1717T RS	211
1508/1 - 1508/2	191	1569/B	197	1639S	201	1693	207	1717T RT	210
1511/1 - 2 - 3	191	1569/F	198	1640	201	1693M	207	1717V	211
1515/1 - 2 - 3	191	1569CP	198	1640A	202	1694/L	207	1717V R	211
1516/1 - 2 - 3	191	1570/3	198	1640K	201	1694A/L	207	1718A...M	211
1517	191	1580/8I	198	1640P	202	1694B/L	207	1718A...P	211
1518/...	192	1580GL	198	1640Q	202	1695XS	207	1718A...Q	211
1520/1 - 1520/2	192	1585/5I - 6I - 7I	198	1640T	202	1696	207	1718A...R	211
1528	192	1585GI/5 - 6 - 7	198	1650	202	1696A	207	1718A...S5	211
1529	192	1589PI/50 - 100	198	1650FD	202	1696B	207	1718A...T	211
1529/C7	192	- 150		1650FT	202	1696D	208	1718D...M	211
1529/PG	192	1589VI	198	1651DGT	202	1696S	208	1718D...P	211
1529PI	192	1590	198	1651DGT/IP	202	1699L	208	1718D...Q	211
1530/C5	192	1591	198	1652	202	1699L/1	208	1718D...R	211
1530/C16	193	1593	199	1654	202	1699Q	208	1718D...S5	211
1532	193	1594	199	1654DGT	202	1700N	208	1718D...T	211
1533/...	193	1595	199	1656	202	1700N/PM	208	1719BA8	288
1533PR/1 - 2 - 3	193	1599B	199	1657DGT/2	203	1701BA	288	1719BA12	288
1534/...	193	1599G	199	1658/...	203	1701N	208	1719BMA...B5	212
1535/C...	193	1599F	199	1658/C4	203	1701N/PM	208	1719BMA...M	212
1539	193	1599P	199	1658DGT	203	1701NE/...	208	1719BMA...P	212

INDICE ALFANUMERICO

1719BMA...Q	211	1741U	216	1756D-2OR	219	1771	226	1833XS/1	229
1719BMA...R	212	1742	216	1756G	219	1771BM	226	1833XS/2	229
1719BMA...S5	213	1742/C4	216	1757	219	1771HD	226	1834RR	230
1719BMA...T	212	1742A	216	1757A	219	1771RL	226	1836A	230
1719BMB/P	213	1742A/C	217	1758	219	1772H	226	1836B	230
1719BMC	213	1742A/KR	216	1758A	219	1772H-HS	274	1837C	230
1719BMD...B5	212	1742KR	216	1758B	219	1772M	226	1837F	230
1719BMD...M	212	1742R-A/M...	216	1758B-RNT	220	1772R	226	1837F/USB	230
1719BMD...P	212	1742R-AL/M...	216	1758BA	288	1772RL/2	226	1837M	231
1719BMD...Q	211	1743	217	1758LG	220	1773A	226	1837RB-F/USB	230
1719BMD...R	212	1743HS	273	1758M	220	1773RL	226	1837S	231
1719BMD...S5	213	1743T	217	1758R	220	1774	226	1838/11LED	231
1719BMD...T	212	1748-BA1	524	1758VT	220	1774A	226	1838COB	231
1719BMX...M	212	1748-BA2	524	1758VT/L	220	1774A/RL	226	1838FLASH	231
1719BMX...Q	212	1748-BH	524	1759	220	1774S	226	1838P	231
1719BMX...P	212	1748-BL	523	1759A	220	1776BA	288	1838RA/10-11LED	231
1719BMX...R	212	1748-BP	524	1759B	220	1777BM	227	1838RB/10LED	231
1719BMX...T	212	1748-BR	523	1759HD/3	220	1777BMT	227	1838RR/11LED	231
1719BMX...S5	213	1748-BT	524	1759HD/RR	221	1777MQ/C	267	1838RV/11LED	231
1719BM/RL	213	1748-BT2	524	1759HD/TRUCK	221	1777MQ/U	267	1838RB/FLASH	231
1719BM/RR	213	1748-BT3	524	1759TT	221	1777RL/U	267	1838S	232
1719BMR	213	1748-BV0	523	1760/IR500	223	1777T	227	1838SL	232
1719R/...	213	1748-BV2	522	1760/IR1000	224	1778AX	227	1838SLIM	232
1720/...	213	1748-BX	523	1760/IR1600	224	1778CM	227	1838UV	232
1720/B	213	1748-N2D	523	1760/OHM	222	1778D	227	1839/R1	232
1720/S	213	1748-NA1	524	1760/RMS	222	1778P	227	1839/R2	232
1720D/...	213	1748-NA2	524	1760/RSE	223	1778SCL	227	1839/R4	232
1720D/B	214	1748-NL	523	1760/TC2	223	1778SOS	227	1840BM	232
1721/B6	214	1748-S	525	1760B	222	1778SOS-HS	274	1842LED/ABM	232
1723	214	1748-SC	525	1760BHS	273	1778U	227	1842LED/BM	232
1725	214	1748-ST	525	1760DGT	221	1778V18	227	1843BM	232
1725CR	214	1748-UL	522	1760DGT/2	221	1778X	227	1843R/BM	233
1725MQ	267	1748N	522	1760DGT-R3	223	1781	228	1846LED/ABM	233
1726	214	1749	217	1760K	223	1783	228	1846LED/BM	233
1726BM	214	1749A	217	1760PA/80	222	1784	228	1846R-LED/BM	233
1727	214	1749A/RB	217	1760PA/AC	222	1784BA	288	1848	233
1727BA	288	1749A/RT	217	1760PA/AC-DC	222	1800/100	228	1850B	233
1727BM	214	1749AC	217	1760PT	223	1808	228	1850C	233
1727HS	273	1750	217	1760R/TC2	223	1812 150	228	1850U...	233
1728...	214	1750CG	217	1760TMC	224	1814M	228	1851VK	233
1728BA	288	1750HS	273	1761	224	1820	228	1851VK-12C	233
1729	214	1750KG10	218	1761RS/1	224	1820 60	228	1851VK-12V	233
1729CG	214	1750M	218	1762	224	1820 80	228	1852R1750	234
1729DM 450	214	1750R/1 - 1750R/2	217	1762K	537	1822	228	1852S-F	234
1729LR	214	1750RC	217	1763	224	1822 180	228	1852S-FLESS	234
1730	214	1750RP/1 - 1750RP/2	217	1763G/S500	224	1822 320	228	1852S-L	234
1730INOX	278			1765/C24	224	1823 60	228	1852 S-PIATTE	234
1730M	214	1750RT	217	1766	224	1823R/60	228	1860 140A	234
1730V 38	214	1750TA	218	1766/8	225	1824R	228	1860 160A	234
1736A	215	1750TLA	218	1766A	225	1825B	228	1860EI	234
1737	215	1751	218	1766ER	225	1827	229	1860RC	234
1737AC	215	1751R	218	1766G	225	1827/K	229	1860RG	235
1737B	215	1752	218	1766I	225	1827F	229	1860SQ	235
1737BA	288	1752R	218	1766L	225	1827PC	229	1870	235
1737NX	215	1753	218	1766LI	225	1827PCL	229	1870-20/5S	236
1738	215	1753R	218	1766T	225	1827PFL	229	1870-72 /FC	236
1739B	215	1754	218	1767A	225	1830T	229	1870-72/FL	237
1740A	215	1755	219	1767PMC	225	1833L	230	1871M	236
1740B	215	1756	219	1767PMR	225	1833L/USB	229	1871M/AS	236
1741B	215	1756B	219	1770	225	1833M	230	1872L	236
1741B/C5	215	1756C	219	1770A	226	1833RB-L/USB	229	1872L 35/FC	237
1741BP	215	1756C-2OR	219	1770BM	226	1833S	229	1872L 35/5S	237
1741RV...K	216	1756D	219	1770RL	226	1833XL	230	1873	236

INDICE ALFANUMERICO

1873-30/5S	237	1895 27	242	1924F	293	1938R/S5	302	1996MQ/T	267
1874	236	1895/RC	242	1927AN	295	1940	303	1996SVG	267
1874-50/5S	237	1895/S	242	1927B	294	1940/S5	303	11001	505
1874-50/FC	237	1895G	242	1927CD	294	1940E10	303	11001H	505
1877	237	1897	243	1927G	295	1940E10/MT	303	11003	505
1877A	237	1897/CRB	243	1927P	294	1940E10/S...	303	11011	505
1878 2	237	1897/G	243	1927SP-AM	295	1940E10/S5	303	11011H	505
1878 3	237	1897/KSA	243	1927XM	294	1940MT	303	11018	505
1878 4	237	1897/MV	243	1928CD	295	1940S...	303	11019	506
1878 8	237	1898/B	243	1928DA	295	1942A	304	11021	506
1878 11	238	1898/D	243	1928DAL	295	1942LR	304	11023	506
1878 30	238	1898/K40	243	1928K4	296	1944A	304	11024	506
1879	238	1901BM/8	309	1928XM	295	1944AR 2	304	11031+11038	506
1879 6	238	1901T/10	309	1930A	296	1944N	304	11032	506
1879/FUEL	238	1910/8 - 1910/10	309	1930CD	296	1944PA	304	11034	506
1879R/K4	238	1914	309	1930HLA	297	1945C	304	11035	506
1880	238	1915B	309	1930LA	296	1945C/G...	305	11037	506
1880ADB	238	1915C	310	1930LH	296	1945C/GP...	305	11038	506
1881	238	1915C/L	310	1930PA	296	1945P	305	11040	507
1882	238	1915D	310	1930ZL	297	1945P/S...	305	11045	507
1883	238	1915E	310	1931AN10	297	1945S	304	11046	507
1883NC	238	1915E/XL	310	1931CD6	297	1945S/G...	304	11048	507
1884	239	1916G	310	1931CD10	297	1946C/T...	305	11049	507
1884/C12	239	1916GF	310	1931CD13	297	1946C4,8	305	11050	507
1889	239	1916GFE	310	1932B10	298	1946C7,8	305	11069	507
1889CF	239	1916I	310	1932B13	298	1946KF	306	11100	508
1885	239	1916JF	310	1932RS13	298	1946KF/M...	306	11101	508
1885/C1	239	1916JM	310	1933	298	1946T	305	11102	508
1885/C1-R1	239	1916P	310	1933AN90	299	1947	306	11105	508
1885/C1-R2	239	1916S	310	1933AN90-H	298	1947G	306	11106	508
1885/C1-R3	239	1917F	311	1933I	299	1947H	306	11107	509
1885/C1-R4	239	1917JF	311	1933IH	298	1947M	306	11110	509
1885/C1-R5	240	1917JM	311	1933IL	299	1947M -...	306	11111	509
1885/C1-R6	240	1917M	310	1933ILH	298	1948	306	11115	509
1885/C1-R7	240	1917RG	311	1933L	299	1948PR	307	11116	509
1885/C1-R8	240	1917SP	311	1934BV	299	1949BC	307	11120	509
1885/C2	240	1917ST	311	1934MAV	299	1949BC/RU	307	11121	510
1885/C2-R1	240	1918	311	1934MAV70	299	1949DGT	308	11125	510
1885/C2-R2	240	1918N	311	1935F	300	1949F	308	11130	510
1885/C2-R3	240	1918R	311	1936/4A	300	1949G	308	11131	510
1885/C2-R4	240	1919F1/2	312	1936/5A	300	1949GPE	308	11132	510
1885/C2-R5	240	1919F1/4	312	1936/7A	300	1949GPN	308	11135	510
1885/C2-R6	240	1919F3/8	312	1937	300	1949M	308	11140	511
1885/C2-R7	240	1919FE1/4	311	1937 2,5	300	1949P	307	11141	511
1885/C3	240	1919L	312	1937C...	301	1949T	308	11145	511
1885/C3-R1	240	1919ML	312	1937K...	301	1949U5	307	11200A	511
1885/C3-R2	240	1919RB-F	312	1937KC	301	1949U5/A	307	11200B	511
1885/C3-R3	240	1919RB-FE1/4	311	1937KL	301	1949U5/B	307	11202A	511
1885/C3-R4	241	1919RF-F	312	1937KL-D	301	1949U5/C	307	11202B	511
1885/C3-R5	241	1919RF-FE1/4	311	1937M	302	1949U5/D	307	11202C	511
1885/C3-R6	241	1919RM-FE1/4	311	1937M-01+11	302	1949U5/E	307	11204A	512
1885/C3-R7	241	1919RM-F	312	1937N10	302	1949U5/F	307	11204B	512
1885/C3-R8	241	1919SC	312	1937N10-GR	302	1949U5/G	307	11204C	512
1885/C3-R9	241	1921B1	293	1937N20	302	1951	309	11208A	512
1885/C3-R10	241	1921M1	293	1937N20-GR	302	1951A	309	11208B	512
1893/134A	241	1921M2	293	1937R/P	300	1952	309	11210A	512
1893/1234YF	241	1921N3	293	1937RT	301	1972/12	289	11210B	512
1893TR/134A	241	1922P1	293	1937RT/R	301	1984/18QM	289	11210C	512
1893TR/1234YF	241	1922P2	293	1937RT/T	301	1995MQ/G1 - G2	267	11212A	512
1893TR/CI	242	1922P3	293	1938	302	1995MQ/T	267	11212B	512
1895 6	242	1924B	294	1938R/L	302	1996MQ/GM	267	11214A	513
1895 13	242	1924CD	294						

INDICE ALFANUMERICO

11214B	513			341RL	41	392C	45
11214C	513			342	41	392RG/C	45
11216A	513			342A	41	393	45
11216B	513	2001/B26	314	30	23	342A/MOL	41
11216C	513	2001/BV	314	30BA	281	342A/RL	41
11218A	513	2005PA/D	314	31	23	342MOL	41
11218B	513	2005PA/S	314	31/B-LSE	23	342P	41
11220A	513	2009ID	314	31BA	281	342P/RL	41
11220B	513	2009N/BV	314	31BA/C	281	342RL	41
11220C	513	2028/VV	314	31BM	23	345	41
11222	514	2028E	314	31BM/D6	23	345C	42
11230A	514	2029E	314	31L	23	345SB	42
11230B	514	2029/RT	314	31SE	23	345SB/R	42
11232A	514	2029/VV	314	32	23	345U	42
11234A	514	2032/TE	315	32AU	23	349	42
11234B	514	2032/TV	315	32AUR	23	349/SMAS	42
11240A	515	2033E	315	32BA	281	349/SMM	42
11240B	515	2033 P/VV	315	34	23	350	42
11242A	515	2036/TV	315	34BA	281	351C	42
11242B	515	2036E	315	34INOX	276	351P	42
11246A	515	2037/TV	315	35	23	352C/U	42
11248A	515	2038/TV	315	35HS	269	352U	42
11248B	515	2041UC	316	35PM	23	353N	42
11259	515	2051N	316	35PMR	23	353N/C6	43
11260	516	2055HB	316	36	24	353NM	43
11263	516	2060/VV	316	37	24	355	43
11264	516	2080/D10	316	37PM	24	357F3	43
11265	516	2080/V6	316	37PMR	24	357R/F3	43
11265	516	2080/V6-U	316	38/DS1	540	358	43
11266	516	2080/V12	317	38/DS2	540	358RL	43
11268	516	2080/V12-...	317	39BA	281	359	43
11271A	516	2115	319	39INOX	276	359CH	43
11271B	516	2115P L-MQ32	265	310	39	360	43
11271C	516	2115PL-MQ32	320	310/C4	39	360HS	270
11276A	516	2116	320	310/C8	39	360R/...	43
11276B	516	2117	320	310B	39	362	43
11276C	516	2118	320	311	39	362INOX	277
11300A	517	2119	320	330	39	362R/...	43
11300B	517	2119L	320	330BA	283	363	44
11300C	517	2120	320	330BA/2R	283	363BA	283
11300D	517	2200-COVER C22S	355	330R/A	40	363R/...	44
11300E	517	2250-O	243	330R/I	40	365	44
11300F	517	2251-O	243	331L	40	365R/...	44
11300G	517	2252	244	331LR/L	40	366	44
11320	517	2252KR4	244	332	40	374	44
11411	517	2254C	244	334	40	374K	528
11415B	517	2254F	244	334R	40	374R/...	44
11420B	518	2254K	244	334R/I	40	375	44
11431	518	2254SM	244	336	40	376	44
11435	518	2254T	244	338	40	378	44
11440A	518	2258-O	244	338R	40	378BA	283
11440B	518	2300-COVER C23S	355	338R/I	40	383	44
11440C	518	2300-COVER C23ST	355	338RP	40	383R	44
11450A	518	2300ST/KIT	326	339A	40	384	44
11450B	518	2400-COVER C24S	355	339A/R	40	384RC	44
11450C	518	2400-COVER C24SA-XL	355	340	41	386A	45
11488PF	519	2400S/PF	337	340RL	41	386A/RC	45
11491	519	2400S-R/PC	337	341	41	386BA	283
11493	519	2499PC	337	341B	41	388	45
11495	519	2499PF	337	341B/RL	41	388A	45
11498	519	2499PF/M	337	341B/RM	41	388C/C8	45

INDICE ALFANUMERICO

565/4R	64	5958U	440	678/CV	72	6600 M/542	550	720MC	73
565/5R	64	5980/MQ	448	680	72	6600 M/548	550	720MC/C13	74
565VV-B	64	5980EL/A	450	682	72	6600 M/561	550	720ME	75
567/4R	64	5980EL/B	451	6888	545	6600 M/583	550	720ME/C8	75
567/5R	64	5980ET/A	446	6200AP/S10	591	6600 M/640	551	720MRC	75
581	65	5980ET/B	447	6600 M/14	546	6600 M/650	551	720S	74
583	65	5980ID	452	6600 M/22	546	6600 M/657	551	720S/SB6	74
583/C31	65	5980U/BIKE	441	6600 M/27	546	6600 M/658	551	720TC	75
588	65	5988 VHB-MQ	449	6600 M/29	546	6600 M/716	551	720TC/S5	75
590 - 592	65	5988H/7M	442	6600 M/33	546	6600 M/813	551	720TX	75
594	65	5988L/4M	443	6600 M/40	546	6600 M/842	551	720TX/C6	75
596 - 598	66	5988U6/M	444	6600 M/42	546	6600 M/852	551	727/C16	76
599DGT	66	5988U/7M	429	6600 M/44	546	6600 M/856	551	727/ES16	76
599DGT-AN	66			6600 M/47	546	6600 M/857	551	727/ES16TX	76
5000MS	361	6		6600 M/51	546	6600 M/871	551	727/ES22	76
5700LAMP	367			6600 M/52	546	6600 M/878	551	727/ES22TX	76
5902MT	453	600	66	6600 M/58	546	6600 M/881	552	727/ES32	77
5902MT/AS	454	601C	66	6600 M/59	547	6800VE	545	727PI/16	76
5902VI	412	601CA	66	6600 M/61	547	6888B1/2	539	727PI/22	76
5904VG/2M	455	603	67	6600 M/62	547	6888B1/4	539	727PI/32	77
5904VG/2T	456	604B	67	6600 M/63	547	6888B3/8	539	728	77
5904VG/3	457	605E	67	6600 M/73	547			728/15	77
5904VG/3T	458	606MQ/50	263	6600 M/112	547	7		728/16	78
5904VG/5T	459	611	67	6600 M/116	547			728/21	78
5904VI/1T	413	612 ÷ 614	67	6600 M/120	547	73	27	728/22	78
5904VI/2T	414	614/50	67	6600 M/125	547	73/B	28	728/22L	78
5904VI/3T	415	615	67	6600 M/126	547	73/S	28	728/25	78
5904VU/1M	422	616	67	6600 M/131	547	78	28	728/C10	77
5904VU/2M	423	617	67	6600 M/174	547	78AS	28	728/OR	78
5904VU/2T	424	619	67	6600 M/175	548	78BA	282	728/SP	78
5904VU/3T	425	621	67	6600 M/217	548	78BA-AS	282	728AS	77
5904VU/4T	426	641	67	6600 M/218	548	710	73	728FTX	77
5905VG/1	460	642	68	6600 M/222	548	710/16	73	728L	77
5905VG/2	461	643	68	6600 M/223	548	710/20	73	728L/S	77
5908VG/2T	462	650A	68	6600 M/230	548	710/21	73	728LQ	77
5908VI/2T	416	650H	68	6600 M/236	548	710/25	73	728LS	77
5908VU/2T	427	652	68	6600 M/241	548	710/C10	73	729	78
5910VG/3T	463	653	68	6600 M/242	548	710/OR	73	729/15	78
5910VI/3	417	659/15	68	6600 M/253	548	710/SP	73	729/16	78
5910VI/3T	418	659/16	69	6600 M/311	548	720	73	729/21	78
5914VU/M	428	665	69	6600 M/315	548	720/15	76	729/22	78
5915VU/0	430	665LB	69	6600 M/320	549	720/16	76	729/25	79
5915VU/1	431	665SW	69	6600 M/326	549	720/20	76	729/OR	79
5915VU/2	432	666HS	270	6600 M/327	549	720/21	76	729/SP	79
5915VU/3	433	666N	69	6600 M/330	549	720/25	76	729L	78
5915VU/4	434	666N LBF.IN	70	6600 M/371	549	720/C12	73	729LS	78
5915VU/5	435	667N	70	6600 M/379	549	720/C6	73	729T	78
5915VU/AS	436	668N	70	6600 M/406	549	720/OR	76	730	79
5927VU/M	437	668RG	70	6600 M/417	549	720/SP	76	730/15	79
5935ET/1MB	445	668RGC	70	6600 M/423	549	720AS	74	733/15	79
5935VG/1MB	464	669N	71	6600 M/424	549	720FTX	75	7041LCD/4S	235
5935VI/2MB	419	671B/C5	71	6600 M/427	549	720FTX/SB	75	7041LCD/4S-VE	235
5938U/2T	438	671B/C10	71	6600 M/430	549	720IC	74	7041LCD/4S-VI	235
5940SBK	465	671N/C10	71	6600 M/440	550	720L	74	7042LCD	235
5941VU/M	466	671N/C20	71	6600 M/456	550	720L/S3	74	7042LCD/RV	235
5945VUM	467	671N/C30	71	6600 M/465	550	720LC	74	7042LCD/RV-INT	235
5954VG	468	677	71	6600 M/480	550	720LC/C3	74	7043	235
5954VI	420	677/C	72	6600 M/485	550	720LC/S5	74	7051MP	590
5957U-P	439	677/CP200	72	6600 M/510	550	720LCL	75	7061TC	590
5957VG	469	678/C	72	6600 M/532	550	720LCL/C3	75	7076BC	590
5957VI	421	677/CV	72	6600 M/534	550	720LS	74		

INDICE ALFANUMERICO

7076BD	590	7320NA	568	7821	587	851SR	79	867RTX/L	85
7076BP	590	7321NA	568	7823	587	850MQ	263	867TX	85
7076BU	591	7328EA	559	7825	587	852	79	867TX/L	85
7093BC	591	7328EN	559	7829	588	855P	79	867XZN	84
7093BD	591	7340B	572	7830ST	586	860/55	80	867XZN/L	84
7104 90	590	7340R	572	7831ST	586	860/58	80	882	86
7105 6	590	7341N	572	7833ST	586	860/58K	528	882AN	86
7109A	590	7349RP	573	7835ST	587	860/C27	80	882M	86
7109D	590	7350RP	573	7840BL	582	860/C38P	81	882M1	86
7195A	590	7352A	570	7849BL	583	860LP	79	882MSR	86
7200BKK	564	7352B	570	7860G	583	860MIX/A10	81	882P	86
7201BKK	564	7353Y	570	7861G	583	860MIX/A31	81	892	86
7210BKK	564	7354N	571	7863G	583	860PE	80	895	86
7212FG	561	7355V	571	7865G	583	860PE/A10	80	897	86
7212LG	561	7356G	569	7867G	583	860PH	79	897L	86
7213FG	562	7357G	570	7869G	584	860PHZ/A10	80	8001TZ	596
7214FN	562	7362B	571	7880SC	580	860PZ	80	8001TZ-K	596
7214LN	562	7363N	571	7900B	584	860RTX	80	8001Z	595
7215FN	562	7398 0/G	576	7900G	584	860TX	80	8001Z-K	595
7216BKK	565	7398EF	576	7900P	584	860TX/A10	81	8002ZD	596
7217FB	563	7398GEL	576	7900V	584	861/C61P	83	8002ZS	596
7217FG	563	7398U	576	7901G	584	861LP	81	8003ZD	596
7218FN	563	7399A/N	576	7903G	585	861PE	82	8003ZS	596
7219FY	563	7421	576	7903P	585	861PH	81	8004ND	596
7220PEK	560	7423	576	7905G	585	861PH/C	81	8004NS	596
7221PEK	560	7425	576	7904N	585	861PZ	81	8005TZ	594
7223PEK	560	7427	576	7907G	585	861PZ/C	82	8005TZ-K	594
7224PEK	561	7429	576	7907P	585	861RIBE	82	8005Z	593
7235BK	565	7431P	576	7909G	585	861RTX	82	8005Z-K	593
7236BK	566	7525	578	7909V	586	861SP	82	8006Z	594
7238WR	566	7528	578	7909P	586	861TQS	82	8006Z-K	594
7241BK	557	7529	578	7909B	586	861TRW	82	8007Z	594
7241CK	557	7547BL	580	7930G	588	861TX	82	8007Z-K	594
7241EN	556	7547G	580	7931G	588	861TX/C	82	8008N	594
7243BK	557	7547N	580	7933G	588	861XZN	82	8008N-K	594
7243CK	558	7549BL	580	7935G	588	862F	83	8008TZN	594
7243CR	558	7549G	580	7939G	588	862F/A7	84	8009FD	597
7243EN	556	7549N	581	7970	589	862LP	83	8009FS	597
7243FT	558	7575N	581	7971L	589	862PE	83	8009TZ	595
7245BK	558	7577N	582	7978L	589	862PH	83	8009TZ-K	595
7246BK	559	7579T	582	7979	589	862PH/L	83	8009Z	595
7246E	556	7634B	581	7980N	590	862PH-XL	83	8009Z-K	595
7247BK	559	7634G	581	7980R	590	862PZ	83	8010TZ	595
7248GK	566	7635N	581	7984G	590	862TX	83	8010Z	595
7249GK	566	7650	578	7985	590	862TX/L	83	8010Z-K	595
7252NKK	567	7654N	581	7991N	589	862TX-XL	83	8016	598
7253NKK	567	7657N	581	7992N	589	866LP	84	8016DA	598
7293HM	574	7658N	582			866PE	84	8016FR	598
7293HN	575	7659N	582			866PH	84	8016FR-K	598
7294HM	575	7734	582			866PZ	84	8016-K	598
7294HMC	575	7780T	582	80	28	866RTX	84	8016U2	598
7294HN	575	7800G	590	80/S	28	866TX	84	8016UGK	599
7300FT	574	7810	578	83	28	867...	85	8016U-K	598
7300MK	573	7811	579	83/S	28	867/C20	85	8018E	598
7310CRK	565	7812	579	83AS	28	867/C38	85	8018T	599
7314AB	568	7813	579	83AS/S	28	867/C52	85	8020	599
7314AF	567	7816BL	579	88	28	867PE	84	8020A	599
7315AN	569	7816G	579	88/S7	29	867PE/L	84	8021	599
7317NA	568	7817N	579	89BA	282	867RIBE	85	8025	600
7318AN	569	7819B	580	89MQ	263	867RIBE/L	85	8025-K	601
7319ESD	574	7820	587	851	79	867RTX	85	8026A	601

8

INDICE ALFANUMERICO

8026A-K	601	8096SL	607	8188CG/25	627	8515Z	614	93HS	269
8026R	599	8097	607	8188CU/25	627	8515V	614	93K	527
8026R-K	599	8097SL	607	8188F	627	8515CH	614	94	30
8028	601	8098	608	8188F35	627	8531	614	94/S	30
8028-K	601	8098SL	608	8188VFG2	627	8532	614	94K	527
8029R	600	8100	610	8189	627	8535	614	95	30
8029R-K	600	8105	593	8189A	627	8600 R/11	552	95/S	30
8031R	600	8105-K	593	8189PA	627	8600 R/12	552	95BA	283
8031R-K	600	8109	593	8190	626	8600 R/13	552	95FTX	30
8032	600	8109-K	593	8190B	626	8600 R/113	552	95FTX/S	30
8032-K	600	8110	593	8201T	616	8600 R/114	552	96	30
8040EN	603	8114	613	8205	616	8600 R/225	552	96/B	30
8040EN-K	603	8116	613	8206	616	8600 R/412	552	96/BG7	30
8040EZ	603	8120	612	8207	616	8600 R/511	552	96/BGS7	30
8040EZ-K	603	8120B	612	8209	616	8600 R/601	552	96/SC12	31
8041	602	8129	612	8210	616	8600 R/611	552	96/SC9	30
8041-K	602	8143	611	8216	617	8702N	597	96/ST	30
8042EN	603	8146	611	8216-K	617	8709N	597	96/ST6K	527
8042EN-K	603	8146C	611	8220	617	8871	274	96AS	31
8042EZ	604	8130	614	8225	617	8872A	274	96AS/B	32
8042EZ-K	604	8130A	614	8227	617	8872AS	274	96AS/BG7	31
8043	602	8131Z	614	8228	617	8873	274	96AS/G	31
8043-K	602	8131DL	614	8240	618	8877	274	96AS/SC9	31
8044	604	8139DL	615	8240F	618	8877M	274	96AS/IT	31
8048	597	8139Z	615	8242	618	8879	274	96BA	283
8049	601	8139ZCH	615	8242F	618	8880	274	96BA/BP	283
8049A	602	8143/RK	615	8248	616	8883	274	96BAF-AS	283
8050 D	615	8146/RK	615	8249	616	8889C1	496	96BP	32
8051S	610	8150	621	8249G	617	8889C2	496	96BP/AS	33
8051S-K	610	8153	622	8250	619	8889C3	496	96BP/ASB	33
8052 - 8055S	609	8156	622	8264	619	8889C6	496	96BP/AS-SC9	33
8057	609	8157	622	8267	620	8889CD	496	96BP/SC9	33
8057R - 8057	609	8158	622	8272	620	8889CS	496	96BPA	33
8058R - 8058	609	8159	622	8273	620	8889I4	496	96BPA/SC9	33
8058R/PS	615	8160	622	8274	618	8889P1	495	96BPC	32
8060R - 8060	609	8161	623	8274A	618	8889P2	496	96BPC/SC9	32
8060R/PS	615	8166	624	8274G	619	8889P3	496	96BP-CL	32
8061F	609	8170	623	8276	619	8889P4	496	96BP-CL/SC9	32
8061R - 8061F	609	8173	623	8276G	619	8889PD	496	96BPINOX	276
8062	610	8176	623	8278	619	8889PS	496	96BPINOX-AS	276
8063	610	8177	623	8279	621			96BPINOX-AS/B8	276
8064S	610	8178	623	8280	619			96C/AS	31
8065SC	610	8179A	624	8282	620			96C-AS/SC9	31
8074	612	8179B	624	8282S	620	90	29	96INOXBP/B	276
8074A	612	8179M	624	8284	620	90/B	29	96L	32
8074G	612	8180	624	8285	620	90/S	29	96L/SC12	32
8080	612	8181	625	8286	620	90/SP	29	96L/SP8	32
8082	612	8181S	625	8287	620	90AS	29	96LBP	33
8083	613	8182	625	8290	621	90AS/S	29	96LBP/SC9	33
8085	608	8182A	626	8293	621	90BA	282	96LC	32
8085R	608	8182E	626	8297C	621	90K	527	96LC/SC12	32
8086	608	8182H	625	8297F	621	91	29	96LC/SC8	32
8090F	624	8182S	625	8302Z	597	91BA	282	96N	31
8090R - 8090	609	8182T	625	8303Z	597	91HS	269	96N/B	31
8091	604	8182TS	625	8317DZ	613	91HS-C	269	96N/G	31
8091SL	605	8183	625	8317SZ	613	92	29	96N/SC12	31
8092	605	8184	625	8381SL	613	92BA	282	96N/SC9	31
8092SL	605	8185	626	8381SP	613	92HS	269	96N/ST	31
8094	606	8186	626	8381SX	621	93	29	96N/ST6K	527
8094SL	606	8187	626	8383C	614	93BA	282	96T	33
8096	606	8188C	627	8383P	614	93C	30	96T/AS	34

INDICE ALFANUMERICO

96T/S6	33	900/C11Z	91	910/22	96	910ME	95	920/R55Q	110
96T/S11	33	900/C12MZ	91	910/25	96	910ME/SB	95	920/R55X	110
96T/SP	33	900/C13-5	91	910/25K	530	910MQ/21	263	920A	98
96T/SPV	497	900/C13-8	91	910/36A	96	910MQ/22	263	920A/AS	99
96TAS/S	34	900/C24	91	910/40	96	910MQ/55	264	920A/C11	104
96TBP	34	900/C39	90	910/42	96	910MQ/B	263	920A/C12	104
96TBP/S6	34	900/R55	109	910/46	96	910MQ/C16	264	920A/C12X	104
96THS	269	900/R55-Z	109	910/55	96	910MQ/PE	263	920A/C17HR	107
96THS-AS	269	900/SB	86	910/55K	530	910MQ/PT	263	920A/C20	105
96TK	528	900AN	89	910/55Q	97	910MQ/T	264	920A/C20Q	105
97BTX	34	900AS	87	910/58	97	910MQ/TX	263	920A/C20X	105
97BTX/B	34	900AS/C10	92	910/58K	530	910MQ/XZN	263	920A/C21	105
97BTX/SC8	528	900AS/C17-MBM	92	910/R55	109	910PE	95	920A/C21X	105
97BTX/SC8	34	900AS/L	87	910/R55Q	109	910PE/AS	95	920A/C33	106
97BTX-C	35	900AS/MB	87	910/R55X	110	910PE/SB	95	920A/SB13	98
97BTX-C/SC8	35	900AS/MB-C17	92	910A	93	910PH	95	920A/SB8	98
97BTXL	35	900AS/MBL	87	910A/AS	93	910PH/SB4	95	920A-AS/SB11	99
97BTXL/SC8	528	900AS/SB11	87	910A/C10	97	910PT	95	920AK	530
97BTXL/SC8	35	900BG/30	89	910A/C16	97	910PT/SB	95	920AL	99
97RTX	35	900BG/30C	89	910A/C16HR	98	910TX	95	920AL/SB11	99
97RTX/B	35	900BG/30K	529	910A/C16Q	97	910TX/SB	95	920AN	102
97RTX/SC8	35	900E-HS/55	270	910A/C17	97	910XZN	95	920AS	99
96TINOX	277	900FL	89	910A/C29	98	911BA	283	920AS/C10	106
96TINOX-AS	277	900FTX	88	910A/SB	93	911BA/16	284	920AS/C15	106
96TINOX-AS/S7	277	900FTX/SB9	88	910A-AS/SB13	94	911BA/20	284	920AS/C17X	107
96TINOX/S5	277	900K	529	910AK	530	911BA/55	284	920AS/L	99
97TTX	35	900L	87	910AL	93	914MQ/A	264	920AS/MBM-C21	107
97TTX/S	35	900L/SB	87	910AL/SB14	93	914MQ-A/S4	264	920AS/SB11	99
97TTX/SP	35	900LP	88	910AN	96	920/15	102	920ASL/SB11	99
97TTXHS	270	900M/35	90	910AS	94	920/16	102	920B	99
97TX	34	900M/55	90	910AS/C13	98	920/20	102	920B/C11	104
97TX/B	34	900M/R55	109	910AS/L	94	920/21	102	920B/C12	104
97TX/BG8	34	900MB	87	910AS/MBM-C18	98	920/21K	530	920B/C12X	104
97TX/G	34	900MB/C19	91	910AS/SB13	94	920/22	102	920B/C20	105
97TX/SC8	34	900MB/C28	92	910AS/SN	94	920/23	102	920B/C20X	105
97TX/ST	34	900MB/L	87	910ASL/SB12	94	920/25	102	920B/C21	105
98XZN	35	900MB/SB	87	910B	93	920/25K	530	920B/C21X	105
98XZN/B	35	900MC	87	910B/C10	97	920/35A	102	920B/C30Q	106
99	36	900MC/C24	92	910B/C16	97	920/36A	103	920B/C33	106
99BA	283	900MC/C32	92	910B/C16Q	97	920/38	103	920B/SB13	99
99SQ	36	900MC/LP	88	910B/C29	98	920/40	103	920B/SB8	99
99ST	36	900MC/PH	88	910B/SB	93	920/42	103	920BL	99
99 VN/...	36	900MC/TX	89	910B/SN	93	920/44	103	920BL/SB11	99
900	86	900ME	88	910BL	93	920/46	103	920BP	101
900/...	89	900ME/SB8	88	910BL/SB	93	920/50	103	920BP/SB	101
900/16	89	900PE/AS	88	910BP	95	920/50F	103	920E-HS/55LC	270
900/20LK	529	900PH	88	910BP/SB6L	95	920/55	103	920ES	102
900/25	89	900PH/SB4	88	910CF	96	920/55INOX	277	920ES/SB	102
900/25K	529	900PT	89	910CF/SB	96	920/55K	530	920ES/XL-SB	102
900/32	89	900PZ	88	910E-HS/55	270	920/55L	104	920FTX	100
900/35A	89	900T/44	90	910FTX	94	920/55LC	103	920FTX/C	100
900/40	90	900TX	89	910FTX/L	94	920/55Q	103	920FTX/L	100
900/42	90	900TX/SB	89	910FTX/LSB	94	920/55X	103	920FTX/LSB	100
900/55	90	900U	88	910FTX/SB	94	920/56A	104	920FTX/SB	100
900/55K	529	900U/SB	88	910FTX/XL	94	920/58	104	920INOX-A	277
900/55Z	90	902R/C6	93	910FTX-XL/C10	94	920/58K	530	920LH/SB7	100
900/55ZK	529	910/15	96	910LP	95	920/C37	106	920LP	100
900/58	90	910/16	96	910M/35	96	920/R50	110	920M/35	103
900/58K	529	910/20	96	910M/55	97	920/R55	110	920M/35L	103
900/C11	90	910/21	96	910M/56	97	920/R55INOX	277	920M/55	104
900/C11HR	92	910/21K	530	910M/R55	109	920/R55LC	110	920M/56	104

INDICE ALFANUMERICO

920M/R55	110	928AS	108	951TX/S	113	960T/I	117	998	123
920MC	98	928AS/C12	109	952	113	960T/L	117	999	123
920MC/C14	105	928B	107	952/S	114	960T/M	117	999/B6	123
920ME	101	928B/C12	108	952AS	114	960UC	118	999A	123
920ME/C	101	928ME	108	952FTX	114	960YP	117	999B	123
920ME/SB	101	929	109	952FTX/S	114	961BA	285	999C	123
920MQ/21	264	929/15	109	952L	114	961P6	119	999D	123
920MQ/22	264	929/21	109	953	114	961P6/S	119	999E	123
920MQ/55A	264	929/22	109	953/S	114	962	119	999G	123
920MQ/A	264	929/42	109	953TX	114	962M	120	9500TL	629
920MQ/C16	264	929/55	109	953TX/S	114	962P	120	9501TL	629
920MQ/PE	264	929/C8	109	955	114	963	120	9501TLD	629
920MQ/T	264	929/R55	110	956C	114	963BA	285	9502TL	630
920PE	100	930	110	956E	115	964	120	9503TL	630
920PE/AS	101	930/C	110	956F	115	964BA	285	9504TL	630
920PE/C	101	930/S	110	956L	115	964BA/L	285	9505TL	630
920PE/SB	100	932	110	957	115	965	120	9508TL	630
920PE-AS/SB6	101	932/S	111	959	115	965/S	120	9510	630
920PH	100	932HS	270	959R	115	965BA	285	9515M	633
920PH/SB4	100	933	111	960	115	966/C3	120	9516B	633
920RTX	101	933/S	111	960/22EP	117	966BA	285	9521	632
920RTX/SB	101	935	111	960/C6	117	966BA/V	285	9521OB	633
920TX	101	935/S	111	960/D	117	969B	120	9522A	637
920TX/C	101	935K	530	960A	115	969/C5	120	9523A	637
920TX/C17	107	937	111	960AD/TP2	167	970B	120	9524SC	635
920TX/L-SB4	101	937/S	111	960AVE	117	970C	121	9525/B	632
920TX/SB	101	937BA	285	960AVL	119	970EA	120	9525/N	632
920U	100	937K	530	960BT	115	970EB	120	9525BB	632
920U/SB13	100	940	111	960BT/B	115	970OT	121	9525F	632
920U/SB4	100	941	111	960CMB	117	970Q	120	9525TL	632
920XZN	102	941/S	111	960CMB/R2	117	971/C8	121	9526P	637
920XZN/LS	102	942BX	112	960CMD	118	971TSP	121	9526RMN	637
920XZN/SB12	102	942BX/S	112	960CMD/R1	118	973	121	9527 6T	637
920XZN/SB7	102	943BX	112	960EPC	118	978	121	9527MUG	637
921BA	284	943BX/D	112	960EPC/L	118	979	121	9528B	634
921BA/15	284	943BX/DG	541	960E-PI/P	118	982	121	9533N	630
921BA/21	284	943BX/DG	541	960F	115	984	121	9534B	631
921BA/22	284	943BX/S	112	960G	115	985/B7	121	9534W	630
921BA/25	284	943BXK	530	960H/C4	116	985F	122	9537TL	631
921BA/42	284	943FL	112	960KC-M8/M9/M10	118	985M	121	9539CB	633
921BA/50	284	943FL/S	112	960KPC	118	986 48	122	9541BIKE	632
921BA/R50	284	943MQ	265	960L	115	986 78	122	9541F	632
921BA-AS	284	943MQ/BG	541	960M	116	986PT	122	9541S	632
926BA	284	943MQ/S	265	960P	118	987	122	9542AL	634
926BA/22	285	944BX	112	960PI	119	987AR	122	9542AT	634
926BA/42	285	944BX/D	112	960PI/C19	119	987P	122	9542C	633
926BA/50	285	944BX/DG	541	960PI/S	119	988/K4	122	9542G	634
926BA/R50	285	944BX/S	112	960PMC	119	989	122	9542GW	634
928.../C12	108	949	112	960RPI	119	989A	122	9542M	633
928/15	108	949/S6	112	960S	116	990	122	9542S	634
928/16	108	950	113	960SL	116	991	122	9543C	634
928/20	108	950/S	113	960SN	116	992	122	9544C	631
928/21	108	951	113	960T/A	116	993	122	9547	637
928/22	108	951/S	113	960T/B	116	993G	123	9547T	635
928/25	108	951/SP	113	960T/C	116	993MQ	265	9547WSK	635
928/36A	108	951AS	113	960T/C11	116	993PL	123	9548G	635
928/42	108	951AS/S	113	960T/D	116	994	123	9548KB	635
928/55	108	951BA	285	960T/E	116	994MQ	265	9549BP	637
928/R55	110	951K	530	960T/F	116	994PL	123	9549C	637
928/R55X	110	951MQ	265	960T/G	116	994TF	123	9561V	635
928A	107	951TX	113	960T/H	117	996	123	9561V 2,5	635

INDICE ALFANUMERICO

9561VV	635	9722	501	C23SC	326	C45AS2	408	C55M8	385
9561VV 2,5	635	9724	501	C23ST	326	C45C7	405	C55MA	386
9562P12	397	9726	501	CD23S	325	C45CORNER/W	407	C55MDO	386
9562P2	397	9729	501	C24S/5	327	C45CORNER/X	407	C55MP	392
9557J 2.0	631	9738	501	C24S/6	328	C45LMP	409	C55MS	387
9557J 3.0	631	9740	502	C24S/7	329	C45M5	405	C55P/2MDX-SX	388
9557N	632	9741	502	C24S/8	330	C45M7	405	C55P/MCD	388
9559	635	9742	502	C24SA/6	331	C45M7A/W	404	C55PB/3	375
9559/30MT	635	9743	502	C24SA/7	332	C45M7A/X	403	C55PFA-0,8	390
9562P2	639	9744	502	C24SA/8	333	C45MA	406	C55PFA-1,0	388
9562P12	639	9745	502	C24SA-XL/7	334	C45MS	406	C55PM	388
9562T2	639	9752	502	C24SA-XL/8	335	C45PF	407	C55PM/M0,8	390
9562T3	639	9801L	499	C24SA-XL/9	336	C45PM	408	C55PRO B/2	376
9562TB	639	9802M	499	C24SL	338	C45PW/2-1,3MT	404	C55PRO B/2,8	377
9563G	636	9803H	499	C24SL-CAB	338	C45PW/3-2,0MT	404	C55PRO B-D4	378
9563U	637	9811L	499	C25	339	C45PX/2-1,3MT	404	C55PS	391
9565BBQ	636	9812M	499	C27S	340	C45PX/3-2,0MT	404	C55PSE	391
9565ICE	636	9813H	499	C28	341	C45SL	406	C55PT0,8x0,6	390
9565K	636	9821L	500	C30S	342	C45SS	406	C55PT1,0x0,6	389
9565S	636	9822M	500	C35/6G	343	CA49-G	360	C55PTE-0,8	390
9565T	636	9823H	500	C35/7G	343	CX49-G	360	C55PTE-1,0	389
9569MS	638	9831L	500	C35/8G	344	C50S	361	C55RB	381
9569MS-2	638	9832M	500	C35/9G	344	C51	361	C55STR	397
9569P	638	9833H	500	C37/6	345	CP51	362	C55T3	387
9569S	638	9851	501	C37/7	346	CB52	362	C56	368
9572MB	630	9881U	502	C37/8	347	C54S	364	C56B	368
9574B	632	9882R	502	C37A/7	348	C55	374	C56M	369
9574O	632			C38	350	C55/1PF	390	C56P O	363
9577M	636			C38C	351	C55/2PM	389	C56PL O	363
9579C	636			C38L	350	C55/PF	388	C56W	368
9580S	631	C04TSS-7	279	C38L A	350	C55/PL-1,024	381	C57SA	365
9586K	637	C4 - 2104	317	C38T	351	C55A1	394	C57SB	366
9587 9x14	638	C5 - 2105	317	C39/6	352	C55A1/R42	394	C57SC	366
9587 13x21	639	C5S	317	C39/7	353	C55A2	395	C57SD	365
9588/10PI	639	C6T - 2106	318	C39/8	354	C55A2/R70	395	C57SP	367
9588M	638	C7 - 2107	318	C39MD	356	C55AB	375	C58B	369
9588S/10...	639	C8 - 2108	318	C39SM	356	C55AC	392	C58M	369
9589A/36	639	C9 - 2109	318	C39T	352	C55AE	391	C58M/PA	370
9589B/36	639	C9/RT	318	C41H	357	C55AT1	396	C58P	367
9590B	635	C10 - 2110	318	C41H/CE	358	C55AT2	396	C59A	370
9592B/C50	637	C10S - 2110S	318	C41MS	358	C55B PT/2	381	C59B	371
9592B/P	638	C11 - 2111	319	C41S	357	C55B PT/2,8	381	C59C	371
9592M/50	638	C12 - 2112	319	C42H	358	C55B/1	393	C63 G/C	591
9592MB	638	C13	319	C42MCH	358	C55B/2	376	C68	544
9595 C25	638	C14	319	C43	359	C55B/2,8	377	C68G	544
9595C	638	CP15	319	C45/AW	399	C55B/G	379	C88R/1	545
9595T	638	CP15L	319	C45/AX	399	C55B/GAA	379	C88SE	545
9593A	631	C16	320	C45/BPW-1,3	402	C55B/GAE	380	C88VE	545
9593M	631	CP17	320	C45/BPW-2,0	403	C55B/GDP	379	C99C-V3	323
9593S	631	CP17L	320	C45/BPX-1,3	402	C55B/GDS	379	C99M	324
9593W	631	C18	320	C45/BPX-2,0	403	C55B/GE	380	C99P	323
9594	637	C19	320	C45/BW	400	C55B/VS	381	C99PC	324
9596	638	C19L	320	C45/BX	399	C55B-D4	378	C99P-V3	324
9597P	634	C20	320	C45/CW	402	C55C	393	C99T	324
9598W	633	C22B	321	C45/CX	401	C55C7	382	C99T-V3	324
9598WHP	633	C20L	320	C45/DW	400	C55C8	383	C99V1	322
9599CB	633	C20TSS	278	C45/DX	400	C55CS	385	C99V2	322
9599CB-W	633	C22P	321	C45/EW	401	C55KAI	392	C99V3/2C	323
9710	501	C22S	325	C45/EX	401	C55KAS	392	CB/2	497
9712	501	C20TSS	321	C45/W	398	C55M2	383	CP	409
9720	501	C22W	321	C45/X	398	C55M4	384		
		C23S	325	C45AS1	408	C55M7	384		

G, K

GM 496
KIT/GPS 496

M

M01	471
M02	471
M05	471
M06	471
M13	471
M25	471
M30	471
M31	471
M33	471
M38	471
M39	472
M40	472
M44	472
M45	472
M46	472
M49	472
M50	472
M52	472
M53	472
M55	472
M60	473
M62	473
M63	473
M65	473
M69	473
M75	473
M78	473
M79	473
M82	473
M83	474
M85	474
M86	474
M91	474
M92	474
M94	474
M96	474
M100	474
M105	475
M108	475
M110	475
M112	475
M115	475
M120	475
M121	476
M125	476
M126	476
M127	476
M128	476
M129	476
M133	476
M134	476
M135	476

M136	476
M137	477
M145	477
M153	477
M161	477
M162	477
M166	477
M170	477
M172	477
M174	477
M180	477
M195	478
M199	478
M202	478
M204	478
M208	478
M209	478
M213	478
M214	478
M216	478
M217	479
M218	479
M219	479
M223	479
M224	479
M226	479
M227	479
M230	479
M231	479
M234	480
M236	480
M237	480
M240	480
M264	480
M284	480
M285	480
M289	480
M292	480
M295	480
M305	480
M310	481
MB	496
MB12	481
MB37	481
MB38	482
MB39	482
MB44	482
MB45	482
MB46	482
MB47	482
MB56	482
MB59	483
MB58	483
MB65	483
MB63	483
MB64	483
MC10	481
MC12	481

P, S

PM/5C	409
PM/6C	409
PV	367
S42/17	497
S55/8	497
S55/12	497
S96T/8	497
S951/6	497
S952/10	497
S1719BM	497
SB	496
SGN	497
SPG11 - S1203/8	497
ST2P	497

T

T01	485
T05	485
T06	485
T13	485
T18	486
T19	486
T22	486
T23	486
T31	486
T33	486
T34	486
T40	486
T41	486
T45	486
T46	486
T48	486
T50	487
T52	487
T53	487
T55	487
T56	487
T57	487
T59	487
T63	487
T64	487
T65	487
T68	487
T73	487
T75	488
T76	488
T77	488
T79	488
T80	488
T81	488
T82	488
T83	488
T85	488
T91	488
T92	488
T99	489

T100	489
T101	489
T102	489
T103	489
T105	489
T106	489
T110	489
T112	489
T113	489
T121	489
T137	489
T135	490
T136	490
T138	490
T140	490
T144	490
T145	490
T146	490
T151	490
T153	490
T156	490
T157	490
T160	490
T161	491
T164	491
T167	491
T168	491
T170	491
T171	491
T172	491
T173	491
T175	491
T176	491
T177	491
T180	492
T183	492
T198	492
T199	492
T201	492
T202	492
T204	492
T205	492
T206	492
T207	492
T208	492
T209	492
T211	493
T213	493
T216	493
T221	493
T226	493
T227	493
T228	493
T231	493
T233	493
T234	493
T236	493
T239	493
T241	494
T250	494

T256	494
T259	494
T264	494
T270	494
T273	494
T281	494
T285	494
T284	495
T289	495
T291	495
T297	495
TSPP	497

V

VE1	496
VP1 - VP2	495
VP3 - VP4	495
VP-3SC	495
VP-LS	495
VP-LD	495
VP5	495
VP6	495
VPM0	485
VPM3	485
VPM7	485
VPM7-C	485
VPM8	485
VPM9	485



CONDIZIONI GENERALI DI VENDITA

Gli ordini trasmessi per l'acquisto di prodotti dalla Beta Utensili SpA (d'ora in poi "Beta" o "Società") comportano l'accettazione automatica e senza riserve delle presenti Condizioni Generali di Vendita che costituiscono parte integrante del contratto di vendita. Eventuali deroghe alle stesse saranno efficaci solo se concordate per iscritto dalle parti e limitatamente alle vendite cui si riferiscono.

PRODOTTI

I pesi, le dimensioni, i prezzi, i colori e gli altri dati figuranti nei cataloghi, prospetti, circolari, od altri documenti illustrativi della Società, hanno carattere di indicazioni approssimative.

Beta si riserva di variare in qualsiasi momento, senza preavviso, i dati tecnici o costruttivi dei suoi prodotti.

ORDINI

Le presenti Condizioni Generali di Vendita si intendono approvate dall'acquirente con la trasmissione dell'ordine, ordine che viene ricevuto dalla Società sempre con la clausola "salvo approvazione della casa". Beta può accettare l'ordine mediante spedizione della merce, conformemente all'art. 1327 c.c..

Nell'ordine deve essere specificato il codice dell'articolo e la relative quantità. Le quantità minime sono indicate nel listino per ciascun articolo. Ordini non corrispondenti ad esse, od ai loro multipli, verranno automaticamente adeguati senza previa autorizzazione al Cliente.

RIMANENZE

La Società si riserva la facoltà di evadere l'ordine tutto o in parte ovvero in diverse riprese. Nell'eventualità di ordini non completamente evasi Beta invierà tramite e-mail una distinta riepilogativa delle rimanenze di detti ordini che, salvo espressa richiesta contraria, saranno incluse nella o nelle spedizioni successive. Previa specifica richiesta del Cliente tali informazioni verranno trasmesse via fax.

TERMINI DI CONSEGNA

Eventuali termini di consegna, comunque e dovunque previsti, avranno valore puramente indicativo. La Società declina ogni responsabilità per il caso di ritardo nella consegna che non derivi da suo dolo o colpa grave. Il mancato rispetto dei termini di consegna, purché contenuto in un ragionevole lasso di tempo, non dà diritto al Cliente di richiedere un risarcimento, né di annullare gli Ordini, a meno che, avuto riguardo alla normale tollerabilità ed alla natura del contratto ed alla fornitura, la stessa non abbia più importanza per il Cliente. In questo caso l'onere probatorio sarà a carico del Cliente stesso.

Salvo il caso di dolo o colpa grave della Società, è espressamente escluso qualsiasi risarcimento del danno per mancata o ritardata consegna dei prodotti.

GESTIONE ORDINI, SPEDIZIONI E IMBALLI

Le spedizioni sono effettuate franco destino, con mezzi di trasporto a scelta della Società per gli ordini netti superiori ad € 600,00.

Per gli ordini inferiori ad € 600,00 verrà addebitato a titolo di contributo spese di trasporto il seguente importo:

contributo fisso di € 10,00 fino ad € 199,99

contributo pari al 3,50% da € 200,00 ad € 599,99.

L'imballo è gratuito quando non richiesto di tipo particolare.

Il trasferimento dei rischi relativi ai prodotti ha luogo al momento della loro consegna al Vettore: conseguentemente, i prodotti viaggiano a rischio e pericolo del destinatario anche in caso di spedizione porto franco.

L'Acquirente che sia già cliente abituale potrà utilizzare il **nostro servizio rapido** anche per quantità diverse dall'unità di confezionamento previste. Il costo del servizio verrà addebitato nella misura forfetaria del 6% in sede di fatturazione e le spese di spedizione saranno a carico del Cliente.

PREZZI

L'indicazione di prezzo contenuta in cataloghi, listini, ecc. è meramente indicativa e potrà quindi subire variazioni senza necessità di preventiva informazione. Salvo diverso accordo tra le parti, la merce sarà fatturata ai prezzi in vigore al momento della spedizione.

I prezzi si intendono al netto di iva, di eventuali imposte o tasse, nonché di tributi, diritti ed oneri fiscali o di qualsiasi specie eventualmente gravanti sul contratto che restano a carico esclusivo del Cliente.

PAGAMENTI

Il pagamento deve essere corrisposto direttamente presso la sede della Società in Via Volta n. 18 - 20845 SOVICO (MB) ovvero alla persona munita di autorizzazione scritta con le modalità e nei termini indicati nella fattura.

Sconti per pagamenti a breve termine vanno calcolati sull'importo netto della merce, escluso imballo, spese postali o di trasporto e iva. Trascorsi 15 giorni dalla data della fattura o dal periodo concordato, si intende revocato il beneficio dello sconto condizionato e pertanto la rimessa andrà effettuata per il totale della fattura. Il ritardato pagamento rispetto alla data pattuita darà luogo all'addebito degli interessi di mora di cui all'art. 5 del D.Lgs. 231/02 e produrrà la perdita per il Cliente del beneficio del termine ai sensi dell'art. 1186 cod. civ., rendendo immediatamente esigibili eventuali somme non ancora scadute.

Il Cliente non è autorizzato ad effettuare alcuna deduzione dal prezzo pattuito (ad es. in caso di pretesi difetti dei prodotti), se non previo accordo scritto con la Società.

GARANZIA

I prodotti venduti da Beta sono garantiti in relazione a vizi o difetti di fabbricazione; la garanzia è limitata alla sostituzione o riparazione dei prodotti riconosciuti difettosi presso la sede della Società, con esclusione di qualsiasi diritto al risarcimento dei danni. La suddetta garanzia non si applica a prodotti che presentano normale usura, segni di manomissione o di uso improprio. Le spese di trasporto dei prodotti da sostituire o riparare e dei prodotti sostituiti o riparati sono a carico dell'Acquirente. In presenza dei presupposti di cui al comma precedente Beta sostituirà o riparerà gratuitamente il Prodotto riscontrato difettoso all'origine se reso franco sede della Società con relativo documento di trasporto sul quale dovranno essere indicati, oltre alla dicitura merce difettosa, gli estremi della fattura emessa all'atto della vendita. Salvo il caso di dolo o colpa grave, la Società sarà tenuta, in caso di vizi o mancanza di qualità dei prodotti, unicamente alla riparazione o sostituzione dei prodotti difettosi. È inteso che la suddetta garanzia (consistente nell'obbligo di riparare o sostituire i prodotti) comprende e sostituisce ogni garanzia o responsabilità della Società (sia contrattuale che extracontrattuale) comunque originata dai prodotti forniti (ad es. risarcimento del danno, mancato guadagno ecc.).

RECLAMI

Il Cliente deve denunciare gli eventuali vizi e difetti dei prodotti forniti o l'eventuale mancata o difforme fornitura di tutto o parte dell'Ordine d'Acquisto, a pena di decadenza, entro il termine di 8 (otto) giorni da calcolarsi rispettivamente dalla data di consegna dei prodotti (vizi apparenti) e/o da quella della scoperta dei vizi o difetti (vizi occulti). Nel caso di vizi palesi la denuncia dovrà essere fatta per iscritto a mezzo di lettera raccomandata a.r..

Eventuali contestazioni non danno diritto al Cliente di sospendere o comunque ritardare i pagamenti dei prodotti oggetto di contestazione né, tanto meno, di altre forniture.

La garanzia non opera nel caso in cui l'Acquirente abbia eseguito o fatto eseguire interventi da parte di terzi sui prodotti, senza il preventivo consenso scritto di Beta. La merce difettosa, qualora non presenti inconvenienti dovuti a normale logorio, errato uso o evidente manomissione, verrà riparata o sostituita gratuitamente solo se restituita in porto franco presso la sede della Società, indicando nel documento di accompagnamento la causale e gli estremi della fattura relativa.

RESI

Eventuali resi di merce vengono accettati solo se preventivamente concordati e autorizzati per iscritto; contrariamente saranno rispediti al mittente con trasporto a proprio carico.

In ogni caso nel documento di accompagnamento devono essere indicati la causale del reso ed il numero di autorizzazione ricevuto.

Tali resi dovranno essere inviati presso la sede della Società in Via Volta n. 18 - 20845 SOVICO (MB).

FORO COMPETENTE

Le presenti Condizioni Generali di Vendita sono regolate dalle leggi della Repubblica Italiana. Per tutto quanto non espressamente regolato dalle presenti condizioni, sarà applicata la normativa del codice civile.

Per qualsiasi controversia derivante dal contratto di vendita disciplinati dalle presenti Condizioni Generali di Vendita o ad esso collegata sarà esclusivamente competente il Foro di Monza, fatte comunque salve diverse inderogabili norme di legge.

CONDIZIONI GENERALI DI VENDITA

Gli ordini trasmessi per l'acquisto di prodotti Robur dalla Beta Utensili SpA (d'ora in poi "Beta" o "Società") devono essere inviati alla nostra sede produttiva di Sulmona e comportano l'accettazione automatica e senza riserve delle presenti Condizioni Generali di Vendita che costituiscono parte integrante del contratto di vendita. Eventuali deroghe alle stesse saranno efficaci solo se concordate per iscritto dalle parti e limitatamente alle vendite cui si riferiscono.

PRODOTTI

I pesi, le dimensioni, i prezzi, i colori e gli altri dati figuranti nei cataloghi, prospetti, circolari, od altri documenti illustrativi della Società, hanno carattere di indicazioni approssimative.

Beta si riserva di variare in qualsiasi momento, senza preavviso, i dati tecnici o costruttivi dei suoi prodotti.

ORDINI

Le presenti Condizioni Generali di Vendita si intendono approvate dall'acquirente con la trasmissione dell'ordine, ordine che viene ricevuto dalla Società sempre con la clausola "salvo approvazione della casa". Beta può accettare l'ordine mediante spedizione della merce, conformemente all'art. 1327 c.c..

Nell'ordine deve essere specificato il codice dell'articolo e la relative quantità.

Le quantità minime sono indicate nel listino per ciascun articolo. Ordini non corrispondenti ad esse, od ai loro multipli, verranno automaticamente adeguati senza previa autorizzazione al Cliente.

RIMANENZE

La Società si riserva la facoltà di evadere l'ordine tutto o in parte ovvero in diverse riprese. Nell'eventualità di ordini non completamente evasi Beta invierà tramite e-mail una distinta riepilogativa delle rimanenze di detti ordini che, salvo espressa richiesta contraria, saranno incluse nella o nelle spedizioni successive. Previa specifica richiesta del Cliente tali informazioni verranno trasmesse via fax.

TERMINI DI CONSEGNA

Eventuali termini di consegna, comunque e dovunque previsti, avranno valore puramente indicativo. La Società declina ogni responsabilità per il caso di ritardo nella consegna che non derivi da suo dolo o colpa grave. Il mancato rispetto dei termini di consegna, purché contenuto in un ragionevole lasso di tempo, non dà diritto al Cliente di richiedere un risarcimento, né di annullare gli Ordini, a meno che, avuto riguardo alla normale tollerabilità ed alla natura del contratto ed alla fornitura, la stessa non abbia più importanza per il Cliente. In questo caso l'onere probatorio sarà a carico del Cliente stesso.

Salvo il caso di dolo o colpa grave della Società, è espressamente escluso qualsiasi risarcimento del danno per mancata o ritardata consegna dei prodotti.

GESTIONE ORDINI, SPEDIZIONI E IMBALLI

Le spedizioni sono effettuate franco destino con addebito delle spese in fattura con mezzi di trasporto a scelta della Società.

L'imballo è gratuito quando non richiesto di tipo particolare.

Il trasferimento dei rischi relativi ai prodotti ha luogo al momento della loro consegna al Vettore: conseguentemente, i prodotti viaggiano a rischio e pericolo del destinatario anche in caso di spedizione porto franco.

L'Acquirente che sia già cliente abituale potrà utilizzare il **nostro servizio rapido** anche per quantità diverse dall'unità di confezionamento previste. Il costo del servizio verrà addebitato nella misura forfetaria del 6% in sede di fatturazione e le spese di spedizione saranno a carico del Cliente.

PREZZI

L'indicazione di prezzo contenuta in cataloghi, listini, ecc. è meramente indicativa e potrà quindi subire variazioni senza necessità di preventiva informazione. Salvo diverso accordo tra le parti, la merce sarà fatturata ai prezzi in vigore al momento della spedizione.

I prezzi si intendono al netto di iva, di eventuali imposte o tasse, nonché di tributi, diritti ed oneri fiscali o di qualsiasi specie eventualmente gravanti sul contratto che restano a carico esclusivo del Cliente.

PAGAMENTI

Il pagamento deve essere corrisposto direttamente presso la sede della Società in Via Volta n. 18, 20845 Sovico (MB) ovvero alla persona munita di

autorizzazione scritta con le modalità e nei termini indicati nella fattura.

Sconti per pagamenti a breve termine vanno calcolati sull'importo netto della merce, escluso imballo, spese postali o di trasporto e iva. Trascorsi 15 giorni dalla data della fattura o dal periodo concordato, si intende revocato il beneficio dello sconto condizionato e pertanto la rimessa andrà effettuata per il totale della fattura.

Il ritardato pagamento rispetto alla data pattuita darà luogo all'addebito degli interessi di mora di cui all'art. 5 del D.Lgs. 231/02 e produrrà la perdita per il Cliente del beneficio del termine ai sensi dell'art. 1186 cod. civ., rendendo immediatamente esigibili eventuali somme non ancora scadute.

Il Cliente non è autorizzato ad effettuare alcuna deduzione dal prezzo pattuito (ad es. in caso di pretesi difetti dei prodotti), se non previo accordo scritto con la Società.

GARANZIA

I prodotti venduti da Beta sono garantiti in relazione a vizi o difetti di fabbricazione; la garanzia è limitata alla sostituzione o riparazione dei prodotti riconosciuti difettosi presso la sede della Società, con esclusione di qualsiasi diritto al risarcimento dei danni. La suddetta garanzia non si applica a prodotti che presentano normale usura, segni di manomissione o di uso improprio. Le spese di trasporto dei prodotti da sostituire o riparare e dei prodotti sostituiti o riparati sono a carico dell'Acquirente.

In presenza dei presupposti di cui al comma precedente Beta sostituirà o riparerà gratuitamente il Prodotto riscontrato difettoso all'origine se reso franco sede della Società con relativo documento di trasporto sul quale dovranno essere indicati, oltre alla dicitura merce difettosa, gli estremi della fattura emessa all'atto della vendita.

Salvo il caso di dolo o colpa grave, la Società sarà tenuta, in caso di vizi o mancanza di qualità dei prodotti, unicamente alla riparazione o sostituzione dei prodotti difettosi. È inteso che la suddetta garanzia (consistente nell'obbligo di riparare o sostituire i prodotti) comprende e sostituisce ogni garanzia o responsabilità della Società (sia contrattuale che extracontrattuale) comunque originata dai prodotti forniti (ad es. risarcimento del danno, mancato guadagno ecc.).

RECLAMI

Il Cliente deve denunciare gli eventuali vizi e difetti dei prodotti forniti o l'eventuale mancata o difforme fornitura di tutto o parte dell'Ordine d'Acquisto, a pena di decadenza, entro il termine di 8 (otto) giorni da calcolarsi rispettivamente dalla data di consegna dei prodotti (vizi apparenti) e/o da quella della scoperta dei vizi o difetti (vizi occulti). Nel caso di vizi palesi la denuncia dovrà essere fatta per iscritto a mezzo di lettera raccomandata a.r..

Eventuali contestazioni non danno diritto al Cliente di sospendere o comunque ritardare i pagamenti dei prodotti oggetto di contestazione né, tanto meno, di altre forniture.

La garanzia non opera nel caso in cui l'Acquirente abbia eseguito o fatto eseguire interventi da parte di terzi sui prodotti, senza il preventivo consenso scritto di Beta. La merce difettosa, qualora non presenti inconvenienti dovuti a normale logorio, errato uso o evidente manomissione, verrà riparata o sostituita gratuitamente solo se restituita in porto franco presso la sede della Società, indicando nel documento di accompagnamento la causale e gli estremi della fattura relativa.

RESI

Eventuali resi di merce vengono accettati solo se preventivamente concordati e autorizzati per iscritto; contrariamente saranno respinti al mittente con trasporto a proprio carico.

In ogni caso nel documento di accompagnamento devono essere indicati la causale del reso ed il numero di autorizzazione ricevuto.

Tali resi dovranno essere inviati presso la sede produttiva della Società in Zona Industriale - Contrada S. Nicola - 67039 SULMONA (AQ).

FORO COMPETENTE

Le presenti Condizioni Generali di Vendita sono regolate dalle leggi della Repubblica Italiana. Per tutto quanto non espressamente regolato dalle presenti condizioni, sarà applicata la normativa del codice civile.

Per qualsiasi controversia derivante dal contratto di vendita disciplinati dalle presenti Condizioni Generali di Vendita o ad esso collegata sarà esclusivamente competente il Foro di Monza, fatte comunque salve diverse inderogabili norme di legge.

ORGANIZZAZIONE DI VENDITA



VALLE D'AOSTA

PIEMONTE: Torino, Novara, Vercelli, Biella, Verbano-Cusio-Ossola
MARCO MARTORANA
Cell. 392.4135190
mezzarana@libero.it
marco.martorana1969@hotmail.it

LIGURIA

PIEMONTE: Alessandria, Asti, Cuneo
ALESSANDRO DE SANCTIS
Cell. 348.3008699
Fax 019.90085
alessanc@libero.it

LOMBARDIA NORD OVEST: provincia Nord Milano, Monza, Como, Sondrio, Varese

ALBERTO RADAELLI
Tel. 039.2010558
Cell. 368.946851
Fax 039.2015252
roal2003@tiscali.it

LOMBARDIA SUD OVEST: Lodi, Pavia, Milano città, provincia Sud Milano

LUIGI FUMAGALLI SAS
Cell. 335.214487
Fax 039.570186
lfrappresentanze@tiscalinet.it

LOMBARDIA NORD EST: Provincia Est Milano, Bergamo, Lecco

AVIDANO SIMEONI
Cell. 335.5296941
Fax 02.45500738
ufficio@avidanosimeoni.it

LOMBARDIA SUD EST: Brescia, Mantova, Cremona

VENETO: Verona
MARCO VESENTINI
Cell. 346.0831683
Fax 0376.809741
info@marcovesentini.it

TRENTINO ALTO ADIGE

VENETO: Vicenza
TARGA SERGIO & C. SAS
Cell. 348.4112065
targa_s70@yahoo.it

VENETO: Padova, Rovigo, Belluno, Treviso, Venezia

FRIULI VENEZIA GIULIA
NICOLA MION
Cell. 335.8427204
Fax 0422.452468
n.mion@virgilio.it

EMILIA ROMAGNA: Modena, Parma, Reggio Emilia, Piacenza

MARCO PERVILLI
Cell. 335.7013227
m.pervilli@gmail.com

EMILIA ROMAGNA: Bologna, Ferrara, Ravenna, Forlì-Cesena, Rimini

REP. SAN MARINO
RIEM - MARCO MALAGUTI
Tel. 051.6257778
Cell. 335.5488324
Fax 051.6257627
info@nuovariem.com

TOSCANA

STEFANO CAMERINI
Cell. 347.5084765
Fax 055.289350
camerini.stefano@tiscali.it

MARCHE - UMBRIA

ALEX CAPPANERA
Cell. 339.4718269
Fax 0731.205528
alex@cappanera.it

ABRUZZO - MOLISE: **Beta**

MAURO BISOGNINI
Tel. 071.2862055
Cell. 333.2250049
info@maurobisognini.it
www.maurobisognini.it

ABRUZZO - MOLISE: **Robur**

FRANCESCO BIBONE
Cell. 328/2827915
Fax 085.2058663
fbibone@yahoo.it

LAZIO

DANIELE MARINELLI
Tel. 06.8177774
Cell. 335.5394617
Fax 06.39725066
marinelliagenzia@tiscali.it

CAMPANIA: Benevento, Caserta, Napoli Nord

ANTONINO SCOGNAMIGLIO
Cell. 335.5281534
Fax 081.2140299
antonino.scognamiglio@fastwebnet.it

CAMPANIA: Avellino, Salerno, Napoli Sud

ESPOSITO RAPPRESENTANZE
Cell. 335.6212740
Fax 081.2140299
alfredo-esposito@fastwebnet.it

PUGLIA

PEPE RAPPRESENTANZE S.A.S. DI FRANCESCO PAOLO PEPE & C.
Cell. 329-7955353 (FRANCESCO)
Cell. 393-3334452 (GIANNI)
Cell. 340-8632279 (UFFICIO)
francesco.pepe@hotmail.com
giovanni.pepe@hotmail.com

BASILICATA

VINCENZO GALLITELLI
Cell. 335.1436354
vincenzo.gallitelli@libero.it

CALABRIA

DOMENICO ARAGONA
Cell. 337.872220 (Domenico)
Cell. 339.8740220 (Francesco)
Fax 0984.465320
aragonarappresentanze@gmail.com

SICILIA EST: Messina, Catania, Siracusa, Ragusa, Enna

SALVATORE TUDISCO
Cell. 335.8064374
Cell. 335.6273038 (Biagio Amato: SR, RG)
info@agenziatudisco.it

SICILIA OVEST: Palermo, Trapani, Caltanissetta, Agrigento

DANIELE MARGIOTTA
Cell. 334.8016524
danielemargiotta@tiscali.it

SARDEGNA: Oristano, Cagliari, Carbonia-Iglesias, Medio Campidano

PI.CO - LUCIANO COMPARETTI
Cell. 349.4977448
Fax 070.513150
pico.comparetti@gmail.com

SARDEGNA: Sassari, Nuoro, Ogliastra, Olbia-Tempio

PI.CO - SALVATORE PILLA
Cell. 349.4977449
Fax 079.501493
pico.pilla@gmail.com



IL NOSTRO **SERVIZIO RAPIDO**

1. Possibilità di acquistare qualsiasi articolo a listino senza obbligo di quantità
 2. Consegna in tutta Italia nelle 24 ore per ordini pervenuti entro le ore 11.00 (48 ore per Basilicata, Calabria, Sardegna, Sicilia)
- A. Gli ordini devono essere inviati unicamente tramite fax al numero 800.978.377 o via e-mail a: servizio.rapido@beta-tools.it
- B. Il costo del servizio verrà addebitato nella misura forfettaria del 6% in sede di fatturazione
- C. Le spese di spedizione sono a carico del cliente



È possibile effettuare il ritiro della merce con mezzi propri ai seguenti indirizzi:

- 📍 Magazzino sede Beta – via Volta 18, 20845 Sovico (MB)
- 📍 Polo logistico TIESSE S.p.a. – Via Gaudenzio Fantoli, 28/12 20138 Milano (MI)
- 📍 Centro Logistico di Marzano Geodis – Strada Provinciale 128, km 2, 27010 Marzano (PV)

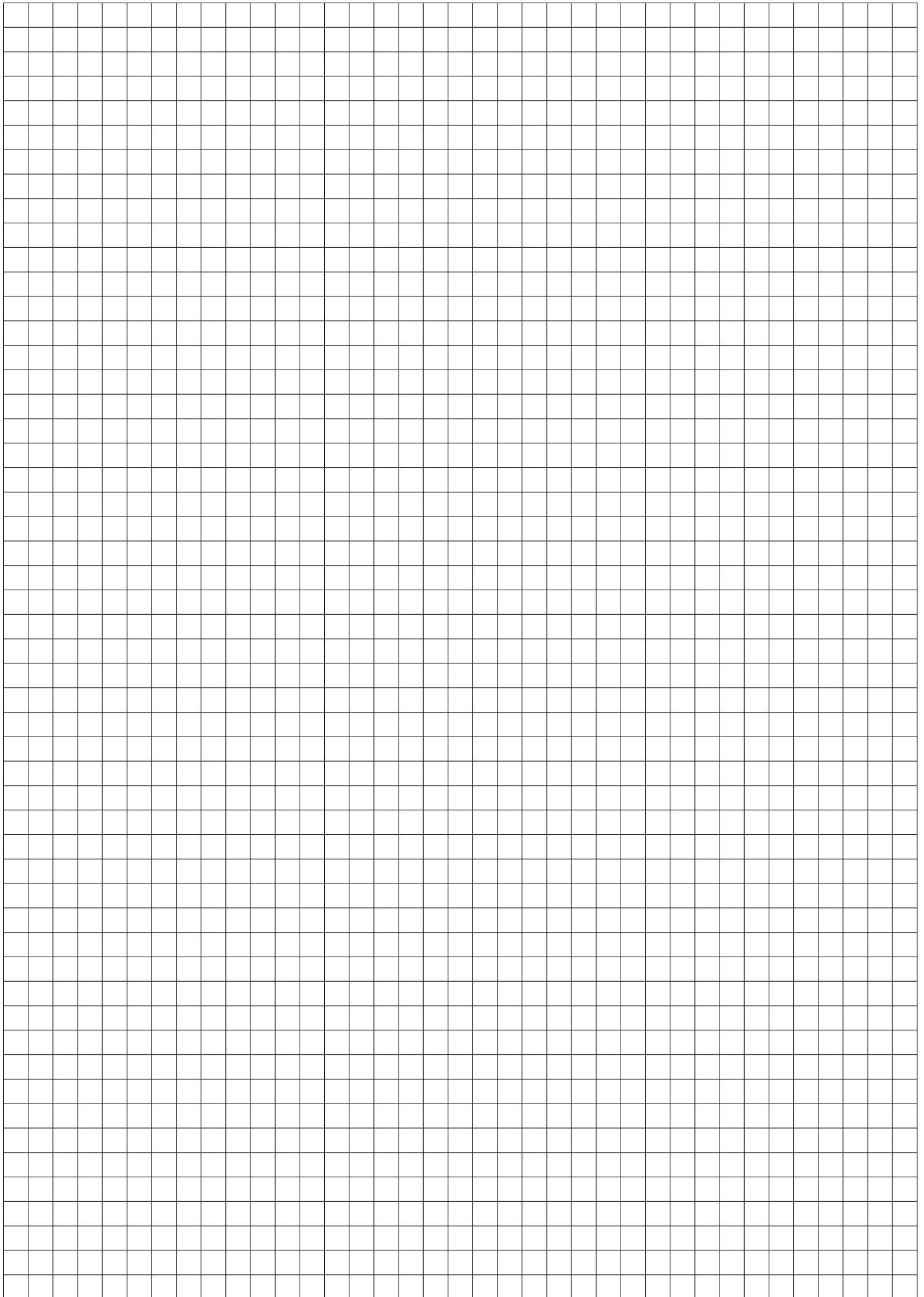

Beta

RSC 55

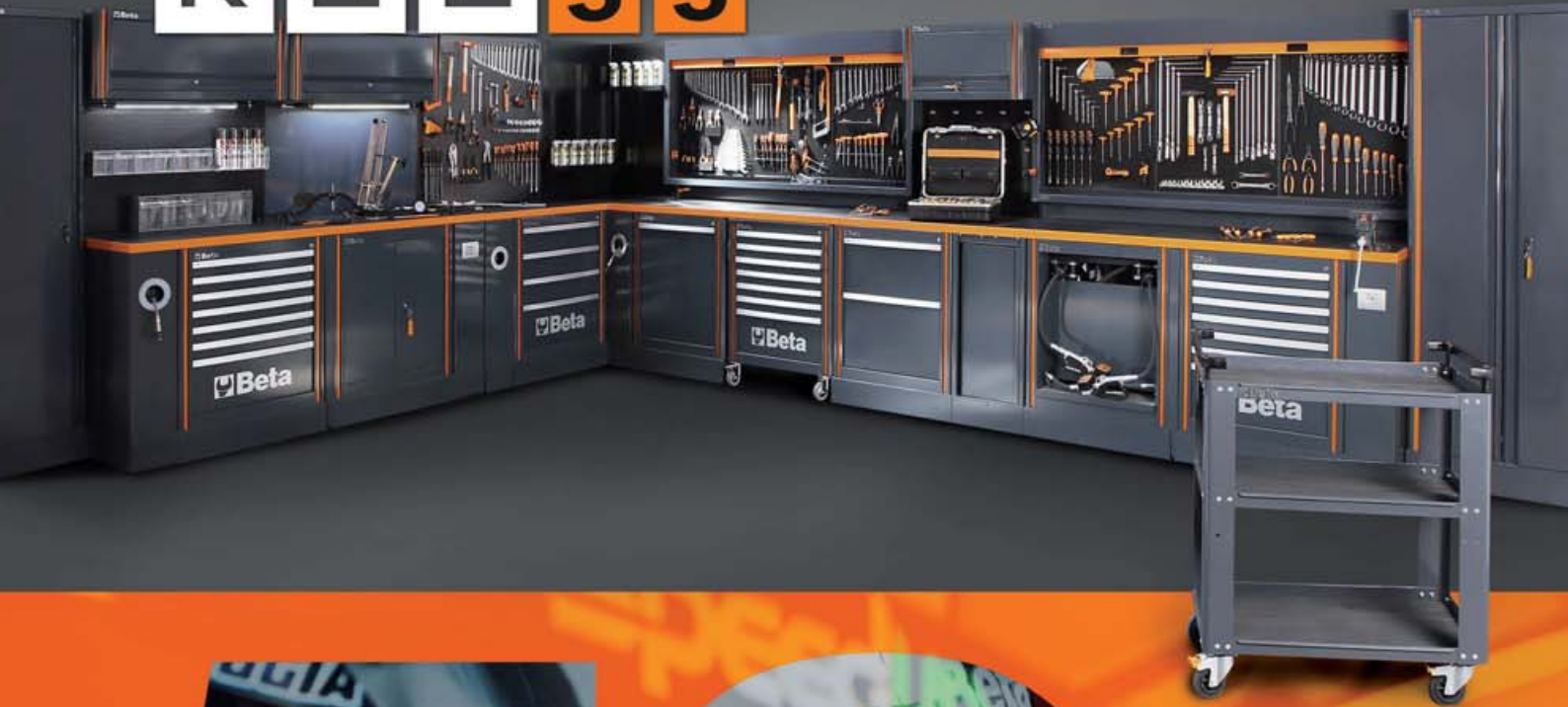

50 years in motorsports



Beta
— GROUP —

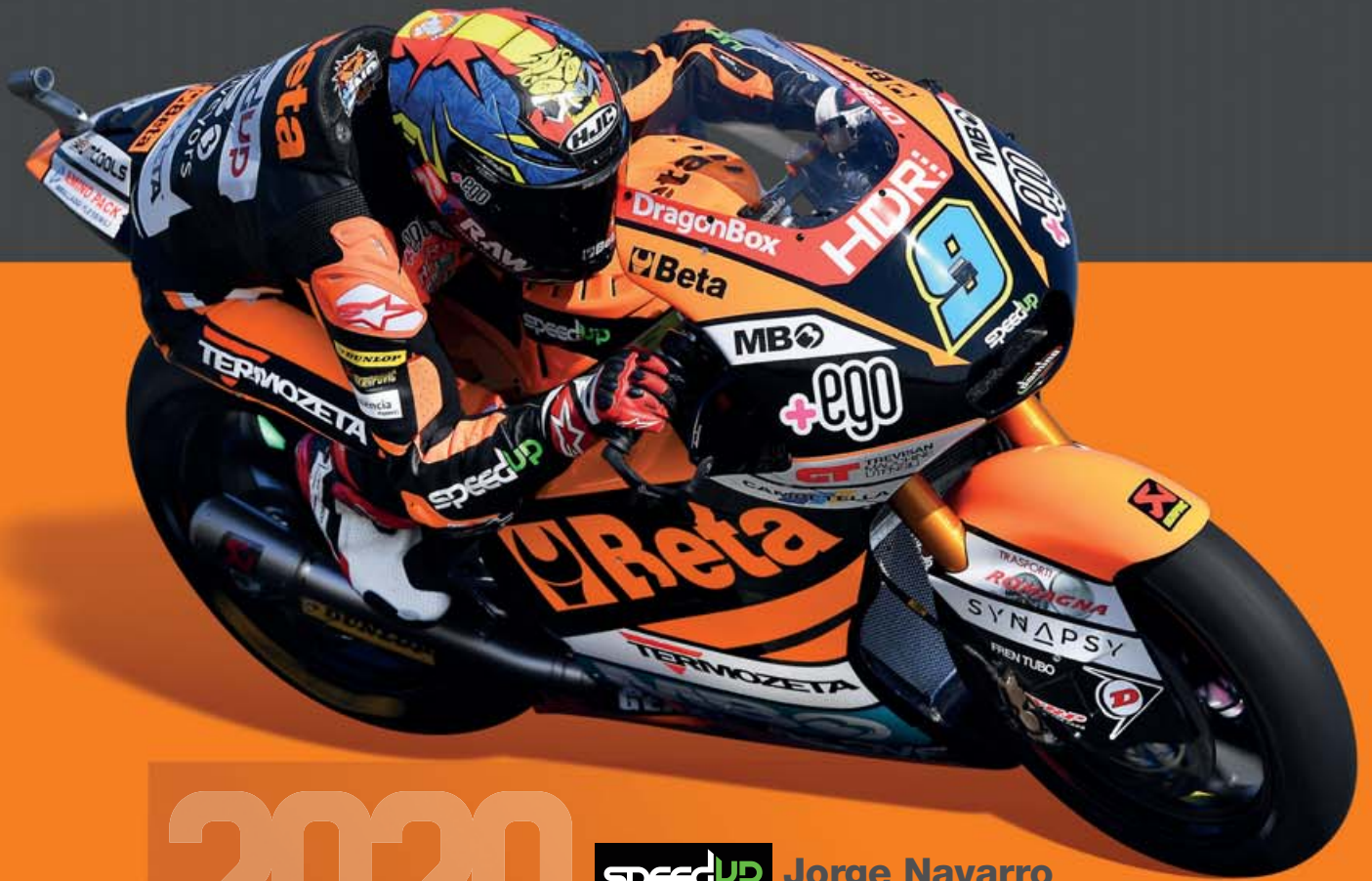

2020



Jorge Navarro
Moto2 World Championship

Partnership



998068900

www.beta-tools.com